

GENE-EHL5

3.5" Subcompact Board

User's Manual 3rd Ed

Copyright Notice

This document is copyrighted, 2022. All rights are reserved. The original manufacturer reserves the right to make improvements to the products described in this manual at any time without notice.

No part of this manual may be reproduced, copied, translated, or transmitted in any form or by any means without the prior written permission of the original manufacturer. Information provided in this manual is intended to be accurate and reliable. However, the original manufacturer assumes no responsibility for its use, or for any infringements upon the rights of third parties that may result from its use.

The material in this document is for product information only and is subject to change without notice. While reasonable efforts have been made in the preparation of this document to assure its accuracy, AAEMON assumes no liabilities resulting from errors or omissions in this document, or from the use of the information contained herein.

AAEMON reserves the right to make changes in the product design without notice to its users.

Acknowledgement

All other products' name or trademarks are properties of their respective owners.

- Microsoft Windows is a registered trademark of Microsoft Corp.
- Intel, Pentium, and Celeron are registered trademarks of Intel Corporation
- Intel Core is a registered trademark of Intel Corporation
- ITE is a trademark of Integrated Technology Express, Inc.
- IBM, PC/AT, PS/2, and VGA are trademarks of International Business Machines Corporation.

All other product names or trademarks are properties of their respective owners.

Packing List

Before setting up your product, please make sure the following items have been shipped:

Item	Quantity
GENE-EHL5	1
M16BT07020 (Heatsink)	1

If any of these items are missing or damaged, please contact your distributor or sales representative immediately.

About this Document

This User's Manual contains all the essential information, such as detailed descriptions and explanations on the product's hardware and software features (if any), its specifications, dimensions, jumper/connector settings/definitions, and driver installation instructions (if any), to facilitate users in setting up their product.

Users may refer to the product page at AAEON.com for the latest version of this document.

Safety Precautions

Please read the following safety instructions carefully. It is advised that you keep this manual for future references

1. All cautions and warnings on the device should be noted.
2. Make sure the power source matches the power rating of the device.
3. Position the power cord so that people cannot step on it. Do not place anything over the power cord.
4. Always completely disconnect the power before working on the system's hardware.
5. No connections should be made when the system is powered as a sudden rush of power may damage sensitive electronic components.
6. If the device is not to be used for a long time, disconnect it from the power supply to avoid damage by transient over-voltage.
7. Always disconnect this device from any AC supply before cleaning.
8. While cleaning, use a damp cloth instead of liquid or spray detergents.
9. Make sure the device is installed near a power outlet and is easily accessible.
10. Keep this device away from humidity.
11. Place the device on a solid surface during installation to prevent falls
12. Do not cover the openings on the device to ensure optimal heat dissipation.
13. Watch out for high temperatures when the system is running.
14. Do not touch the heat sink or heat spreader when the system is running
15. Never pour any liquid into the openings. This could cause fire or electric shock.
16. As most electronic components are sensitive to static electrical charge, be sure to ground yourself to prevent static charge when installing the internal components. Use a grounding wrist strap and contain all electronic components in any static-shielded containers.

17. If any of the following situations arises, please the contact our service personnel:
 - i. Damaged power cord or plug
 - ii. Liquid intrusion to the device
 - iii. Exposure to moisture
 - iv. Device is not working as expected or in a manner as described in this manual
 - v. The device is dropped or damaged
 - vi. Any obvious signs of damage displayed on the device
18. **DO NOT LEAVE THIS DEVICE IN AN UNCONTROLLED ENVIRONMENT WITH TEMPERATURES BEYOND THE DEVICE'S PERMITTED STORAGE TEMPERATURES (SEE CHAPTER 1) TO PREVENT DAMAGE.**

Warning!



This device complies with Part 15 FCC Rules. Operation is subject to the following two conditions: (1) this device may not cause harmful interference, and (2) this device must accept any interference received including interference that may cause undesired operation.

Caution:

There is a danger of explosion if the battery is incorrectly replaced. Replace only with the same or equivalent type recommended by the manufacturer. Dispose of used batteries according to the manufacturer's instructions and your local government's recycling or disposal directives.

Attention:

Il y a un risque d'explosion si la batterie est remplacée de façon incorrecte. Ne la remplacer qu'avec le même modèle ou équivalent recommandé par le constructeur. Recycler les batteries usées en accord avec les instructions du fabricant et les directives gouvernementales de recyclage.

China RoHS Requirements (CN)

产品中有毒有害物质或元素名称及含量

AAEON Main Board/ Daughter Board/ Backplane

部件名称	有毒有害物质或元素					
	铅 (Pb)	汞 (Hg)	镉 (Cd)	六价铬 (Cr(VI))	多溴联苯 (PBB)	多溴二苯醚 (PBDE)
印刷电路板 及其电子组件	○	○	○	○	○	○
外部信号 连接器及线材	○	○	○	○	○	○
<p>O: 表示该有毒有害物质在该部件所有均质材料中的含量均在 SJ/T 11363-2006 标准规定的限量要求以下。</p> <p>X: 表示该有毒有害物质至少在该部件的某一均质材料中的含量超出 SJ/T 11363-2006 标准规定的限量要求。</p> <p>备注: 此产品所标示之环保使用期限, 系指在一般正常使用状况下。</p>						

China RoHS Requirement (EN)

Poisonous or Hazardous Substances or Elements in Products

AAEON Main Board/ Daughter Board/ Backplane

Component	Poisonous or Hazardous Substances or Elements					
	Lead (Pb)	Mercury (Hg)	Cadmium (Cd)	Hexavalent Chromium (Cr(VI))	Polybrominated Biphenyls (PBB)	Polybrominated Diphenyl Ethers (PBDE)
PCB & Other Components	○	○	○	○	○	○
Wires & Connectors for External Connections	○	○	○	○	○	○
<p>O: The quantity of poisonous or hazardous substances or elements found in each of the component's parts is below the SJ/T 11363-2006-stipulated requirement.</p> <p>X: The quantity of poisonous or hazardous substances or elements found in at least one of the component's parts is beyond the SJ/T 11363-2006-stipulated requirement.</p> <p>Note: The Environment Friendly Use Period as labeled on this product is applicable under normal usage only</p>						

Table of Contents

Chapter 1 - Product Specifications	1
1.1 Specifications	2
1.2 Block Diagram	6
Chapter 2 – Hardware Information	7
2.1 Dimensions	8
2.2 Jumpers and Connectors.....	12
2.3 List of Jumpers	14
2.3.1 Clear CMOS Jumper (JP1)	14
2.3.2 Touch Screen 4, 5, 8 Wire Selection (JP2)	14
2.3.3 LVDS Port Backlight Inverter VCC Selection (JP3)	15
2.3.4 LVDS Port Operating VDD Selection (JP4)	15
2.3.5 LVDS Port Backlight Lightness Control Mode Selection (JP5)	15
2.3.6 Auto Power Button Enable/Disable Selection (JP6)	15
2.3.7 COM2 Pin8 Function Selection (JP8)	16
2.3.8 COM3 Pin8 Function Selection (JP9)	16
2.3.9 SMBUS/I2C Connector (JP11).....	16
2.4 List of Connectors.....	17
2.4.1 Battery (CN1).....	19
2.4.2 Touch Screen Connector (CN2)	19
2.4.3 Audio I/O Port (CN3)	21
2.4.4 Amplifier R-channel output (CN4)	22
2.4.5 Amplifier L-channel output (CN5).....	22
2.4.6 M.2 Slot (B-Key 3052) (CN6).....	22
2.4.7 Nano SIM Card Socket (CN7).....	26
2.4.8 M.2 Slot (B-Key 2242) (CN8).....	26
2.4.9 LVDS/eDP Port Inverter / Backlight Connector (CN9)	30

2.4.10	LVDS/eDP Port (CN10)	30
2.4.11	HDMI (CN11).....	32
2.4.12	DP Port (CN13)	33
2.4.13	LAN (RJ-45) Port1 (CN14).....	35
2.4.14	LAN (RJ-45) Port2 (CN15).....	36
2.4.15	SATA Port (CN16).....	36
2.4.16	+5V Output for SATA HDD (CN17).....	37
2.4.17	Digital IO Port (CN18).....	37
2.4.18	Digital IO Port (CN19).....	38
2.4.19	USB 3.1 Ports (CN20).....	39
2.4.20	USB 2.0 Port (CN21).....	40
2.4.21	USB 2.0 Port (CN22).....	40
2.4.22	M.2 Slot (B-Key 2280) (CN25)	41
2.4.23	M.2 Slot (E-Key 2230) (CN26).....	44
2.4.24	COM Port 1~4 (CN27).....	47
2.4.25	eSPI Debug Port (CN32).....	49
2.4.26	CPU FAN (CN33)	50
2.4.27	External Power Input (CN34)	50
2.4.28	External Power Input (CN35)	50
2.4.29	Front Panel Connector (CN36).....	51
2.4.30	PSE Connector (CN37).....	51
2.4.31	CAN BUS (CN38).....	52
2.4.32	VGA Port (CN39).....	53
2.4.33	LAN1 SDP Connector (CN43).....	54
2.4.34	LAN2 SDP Connector (CN44).....	54
2.4.35	DDR4 SO-DIMM (DIMM1).....	54
2.5	Thermal Solution	55
2.6	Electrical Specifications for I/O Port	57

Chapter 3 - AMI BIOS Setup	58
3.1 System Test and Initialization	59
3.2 AMI BIOS Setup	60
3.3 Setup Submenu: Main	61
3.4 Setup Submenu: Advanced.....	62
3.4.1 CPU Configuration.....	63
3.4.2 PCH-FW Configuration.....	64
3.4.2.1 Firmware Update Configuration	65
3.4.3 Trusted Computing.....	66
3.4.4 SATA Configuration.....	69
3.4.5 Hardware Monitor	70
3.4.5.1 Smart Fan Mode Configuration	71
3.4.6 SIO Configuration	73
3.4.6.1 Serial Port Configuration	74
3.4.7 Serial Port Console Redirection	75
3.4.8 SCS Configuration.....	76
3.4.9 Power Management.....	77
3.4.10 Digital IO Port Configuration.....	78
3.5 Setup Submenu: Chipset	79
3.5.1 System Agent (SA) Configuration.....	80
3.5.1.1 Memory Configuration	81
3.5.1.2 LVDS Panel Configuration	82
3.6 Setup Submenu: Security.....	84
3.6.1 Secure Boot.....	85
3.6.1.1 Key Management.....	86
3.7 Setup Submenu: Boot	89
3.7.1 BBS Priorities	90
3.8 Setup Submenu: Save & Exit.....	91

Chapter 4 – Driver Installation	92
4.1 Driver Download/Installation	93
Appendix A - I/O Information	95
A.1 I/O Address Map	96
A.2 Memory Address Map	98
A.3 IRQ Mapping Chart.....	99
A.4 DMA Channel Assignments	101
Appendix B – Mating Connectors and Cables	102
B.1 Mating Connectors and Cables.....	103

Chapter 1

Product Specifications

1.1 Specifications

System

Form Factor	3.5" SubCompact Board
CPU	Intel® Atom™ x6000E Series, Intel® Pentium®, and Celeron® N and J series processors: Intel® Atom™ x6425RE (4C, 1.9GHz, TDP-up to 12W) Intel® Atom™ x6425E (4C, 2.0GHz, up to 3GHz, TDP-up to 12W) Intel® Atom™ x6211E (2C, 1.3GHz, up to 3GHz, TDP-up to 6W) Intel® Pentium® J6426 (4C, 2.0GHz, up to 3GHz, TDP-up to 10W) Intel® Celeron® J6412 (4C, 2.0GHz, up to 3GHz, TDP-up to 10W) Intel® Celeron® N6210 (2C, 1.2GHz, up to 3GHz, TDP-up 6.to 5W) (Intel® Atom™ x6414RE/ x6413E/ x6427FE/ x6200FE/ N6415 by customer's request)
Chipset	Integrated with Intel® SoC
Memory Type	DDR4 3200MHz, SODIMM x 1, up to 32GB, supports IB ECC (selected SKUs)
BIOS	UEFI
Wake on Lan	Yes
Watchdog Timer	255 Levels
Security	TPM 2.0
RTC Battery	Lithium Battery 3V/240mAH

System

Dimension (L X W)	5.75" x 4" (146mm x 101.7mm)
OS Support	Windows 10 (64bit) Linux Ubuntu 20.04.3(IOT)/Kernel 5.13

Power

Power Requirement	+9-36V (Optional: +12V)
Power Supply Type	AT/ATX
Connector	Phoenix 2-pin Connector
Power Consumption	Intel® Atom™ x6425E, DDR4 32GB, 3.26A@ +12V (balance), 3.26A@ +12V (Typical) Intel® Atom™ x6425E, DDR4 32GB, 3.26A@ +12V (balance), 3.42A@ +12V (Max)

Display

Controller	Intel® UHD Graphics for 10th Gen Intel® Processors
LVDS/eDP	LVDS Dual Channel 18/24-bit x 1, up to 1920 x 1080 (Optional eDP 1.3, up to 1920 x 1200)
Display Interface	HDMI 2.0b x 1, up to 4K 60Hz DP 1.4 x 1, up to 4K x 2K 60Hz (Optional: VGA x 1)
Multiple Display	3 Simultaneous Displays

Audio

Codec	Realtek ALC897
Audio Interface	Line-in/Line-out/MIC
Speaker	2W Speaker

External I/O

Ethernet	Intel® i210, 10/100/1000Base x 2
USB	USB 3.2 Gen 2 x 2
Serial Port	—
Video	HDMI 2.0b x 1, DP 1.4a x 1 (Optional: VGA x 1)

Internal I/O

USB	USB 2.0 x 2
Serial Port	RS-232/422/485 x 4
Video	LVDS/eDP x 1
SATA	SATA III x 1 +5V SATA Power Connector x 1
Audio	Audio Header x 1
DIO/GPIO	16-bits (8 In/8 Out)
SMBus/I2C	SMBus/I2C x 1 (Default: SMBus)
Touch	4/5/8-wire Touch Controller x 1 (optional)
Fan	4-Wire Smart Fan x 1
SIM	Nano SIM x 1
Front Panel	HDD LED, PWR LED, Power Button, Buzzer, Reset
Others	eMMC 5.1 32GB CANBUS x 2, TX/RX (Celeron® J6412 and Celeron® N6210 do not support CANBUS)

Expansion

Mini PCIe/mSATA	—
M.2	<p>E-Key 2230 x 1 (PCIe, USB 2.0)</p> <p>B-Key 2242 x 1 (PCIe x2/PCIe/SATA x 1, USB 2.0) (Default: PCIe x2, PCIe x1 select by BIOS, SATA select by BOM)</p> <p>B-Key 2280 x 1 (PCIe x1/PCIe x2, USB 2.0) (Default: PCIe x1, PCIe x2 select by BIOS)</p> <p>B-Key 3052 x 1 (USB 3.2 Gen2)</p>
Others	—

Environment

Operating Temperature	<p>32°F ~ 140°F (0°C ~ 60°C)</p> <p>WiTAS2: -40°F ~ 185°F (-40°C ~ 85°C)</p>
Storage Temperature	-40°F ~ 185°F (-40°C ~ 85°C)
Operating Humidity	0% ~ 90% relative humidity, non-condensing
MTBF (Hours)	335,427
EMC	CE/FCC Class A

1.2 Block Diagram

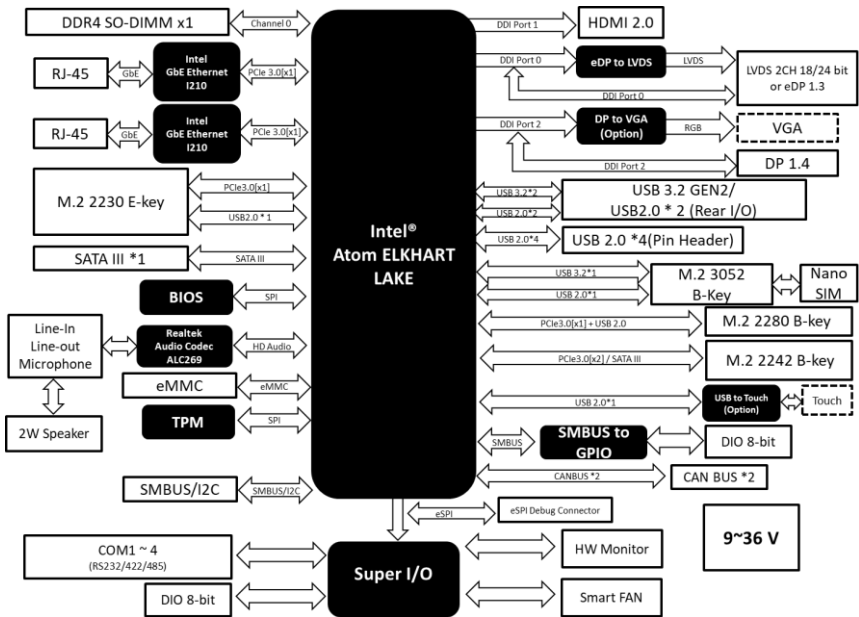

Chapter 2

Hardware Information

2.1 Dimensions

VGA

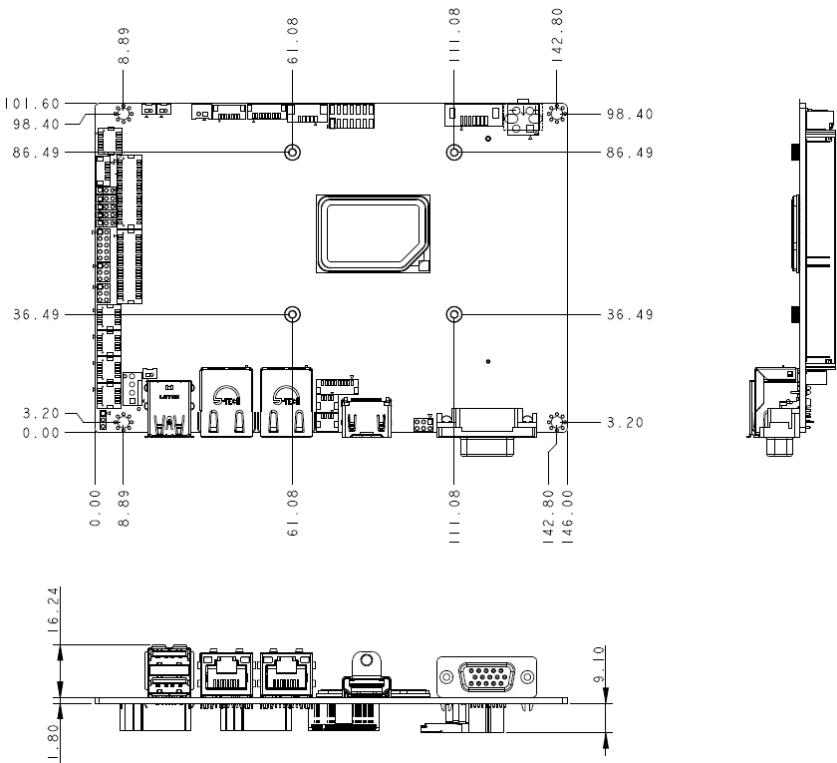

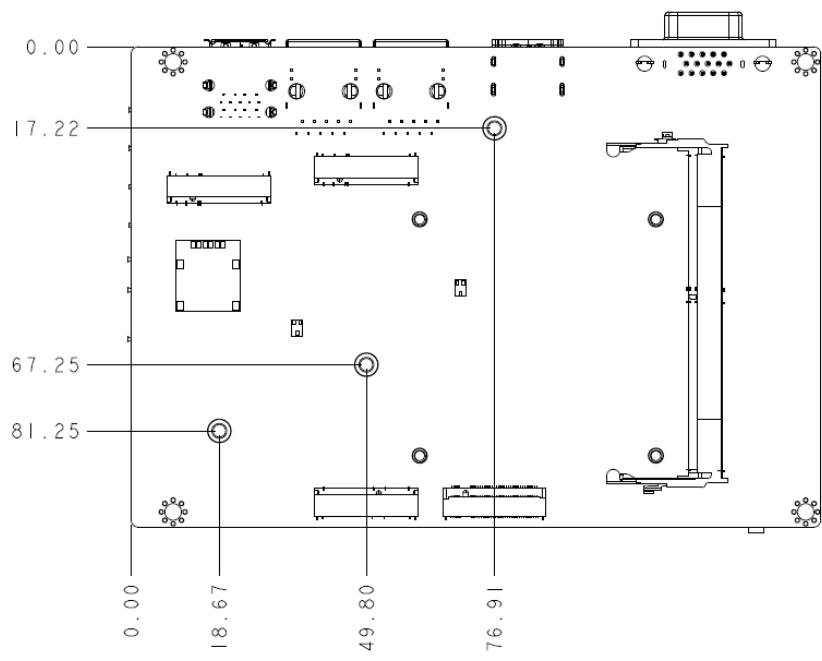

DP

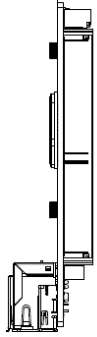
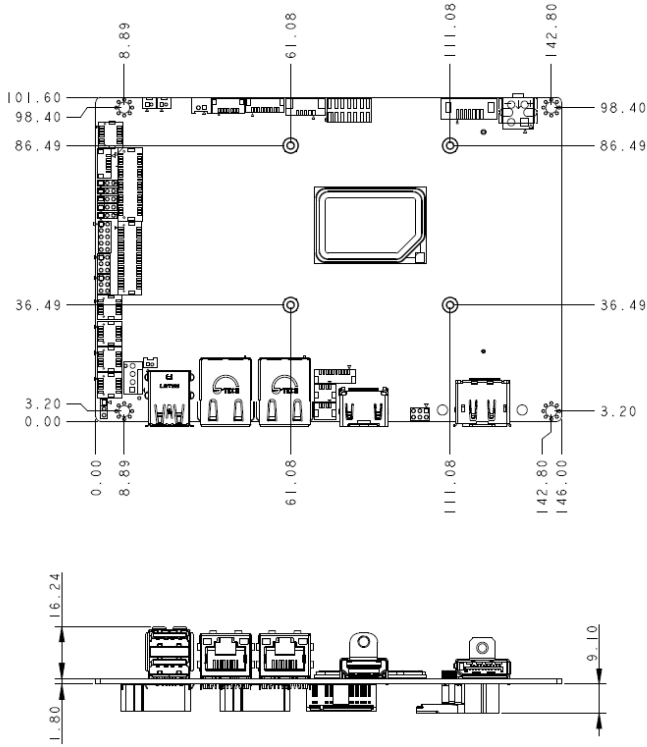

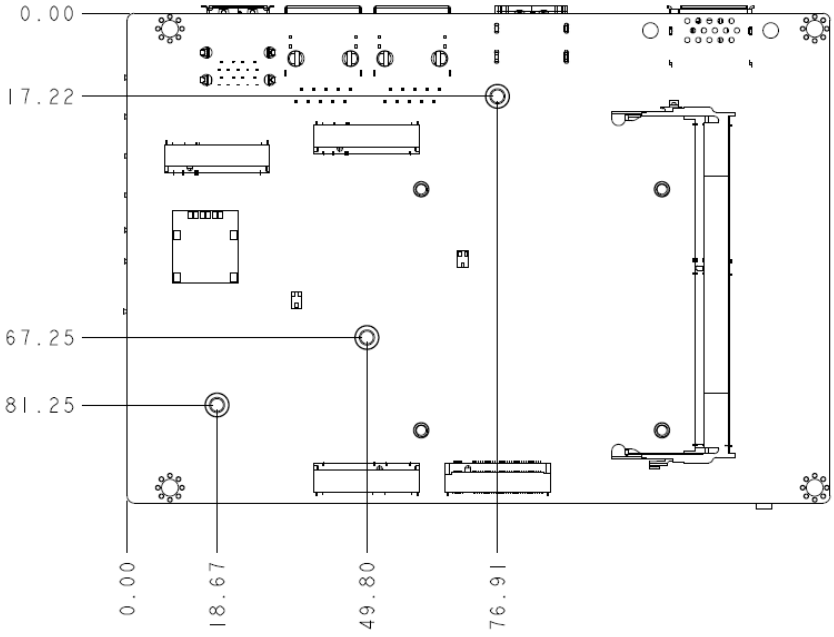

2.2 Jumpers and Connectors

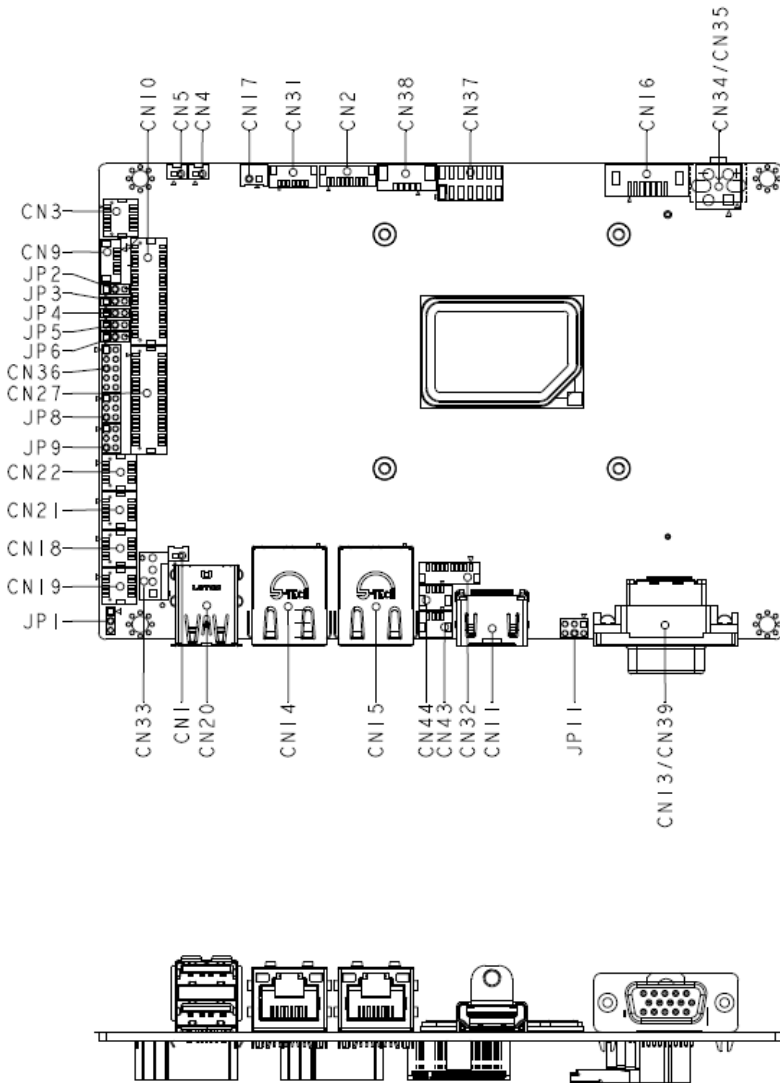

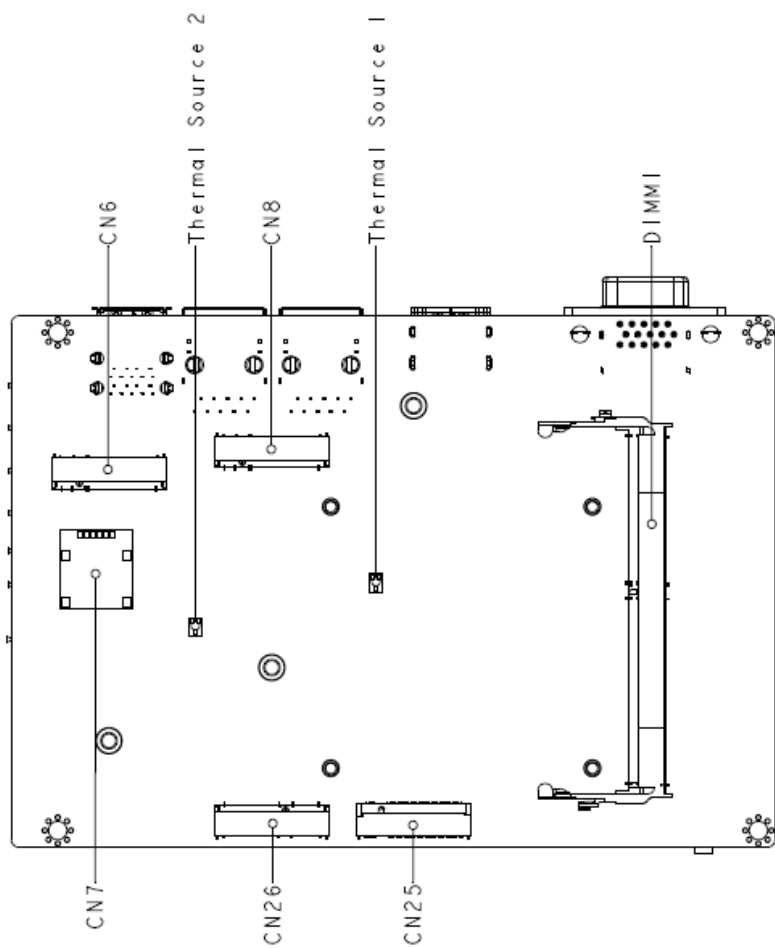

2.3 List of Jumpers

Please refer to the table below for all of the board's jumpers that you can configure for your application

Label	Function
JP1	Clear CMOS Jumper
JP2	Touch Screen 4/5/8-wire Mode Selection
JP3	LVDS Port Backlight Inverter VCC Selection
JP4	LVDS Port Operating VDD Selection
JP5	LVDS Port Backlight Lightness Control Mode Selection
JP6	Auto Power Button Enable/Disable Selection
JP8	COM2 Pin8 Function Selection
JP9	COM3 Pin8 Function Selection
JP11	SMBUS/I2C Connector

2.3.1 Clear CMOS Jumper (JP1)

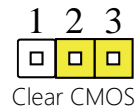
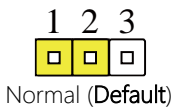

2.3.2 Touch Screen 4, 5, 8 Wire Selection (JP2)

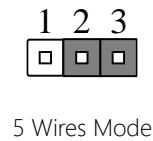
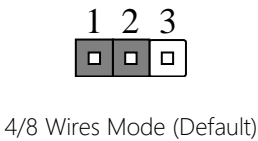

2.3.3 LVDS Port Backlight Inverter VCC Selection (JP3)

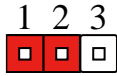

+12V

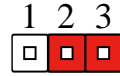

+5V (Default)

2.3.4 LVDS Port Operating VDD Selection (JP4)

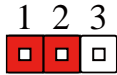

+5V

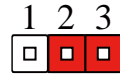

+3.3V (Default)

2.3.5 LVDS Port Backlight Lightness Control Mode Selection (JP5)

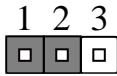

VR Mode (Default)



PWM Mode

2.3.6 Auto Power Button Enable/Disable Selection (JP6)

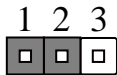

Disable



Enable (Default)

Note: Use power button CN36(1-2) to power on the system when Auto Power Button is Disabled.

2.3.7 COM2 Pin8 Function Selection (JP8)

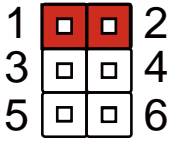

+12V

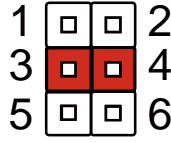

Ring (Default)

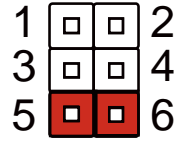

+5V

2.3.8 COM3 Pin8 Function Selection (JP9)

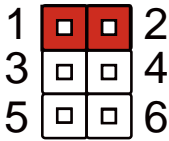

+12V

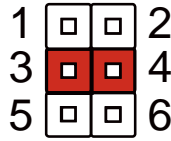

Ring (Default)

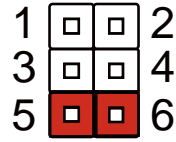

+5V

2.3.9 SMBUS/I2C Connector (JP11)

Pin	Signal Type	Pin	Signal Type
1	SMBUS DATA / I2C DATA	2	+3.3V
3	SMBUS CLK / I2C CLK	4	+1.8V
5	SMBUS INT / INT SERIRQ	6	GND

Default: SMBUS. BOM Change is required for I2C support.

2.4 List of Connectors

Please refer to the table below for all of the board's connectors that you can configure for your application

Label	Function
CN1	Battery
CN2	Touch Screen Connector
CN3	Audio I/O Port
CN4	Amplifier R-channel output
CN5	Amplifier L-channel output
CN6	M.2 B-Key 3052 (USB 3.2 GEN2 / USB 2.0)
CN7	Nano SIM Card Socket
CN8	M.2 B-Key 2242 (PCIe x2 or SATA III)
CN9	LVDS/eDP Port Inverter / Backlight Connector
CN10	LVDS/eDP Port
CN11	HDMI Port
CN13	DP Port
CN14	LAN (RJ-45) Port1
CN15	LAN (RJ-45) Port2
CN16	SATA Port
CN17	+5V Output for SATA HDD
CN18	Digital IO Port
CN19	Digital IO Port
CN20	USB 3.1 Ports
CN21	USB 2.0 Port
CN22	USB 2.0 Port
CN25	M.2 B-Key 2280 (PCIe x1)
CN26	M.2 E-Key 2230 (PCIe x1 / USB 2.0)

Label	Function
CN27	COM Port 1~4
CN31	SPI Program Port
CN32	eSPI Deubg Port
CN33	CPU FAN
CN34	External Power Input
CN35	External Power Input
CN36	Front Panel
CN37	PSE Connector
CN38	CAN BUS
CN39	VGA Port
CN43	LAN1 SDP connector
CN44	LAN2 SDP connector
DIMM1	DDR4 SODIMM

2.4.1 Battery (CN1)

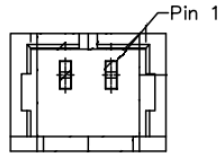

Pin	Pin Name	Signal Type	Signal Level
1	+3.3V	PWR	3.3V
2	GND	GND	

2.4.2 Touch Screen Connector (CN2)

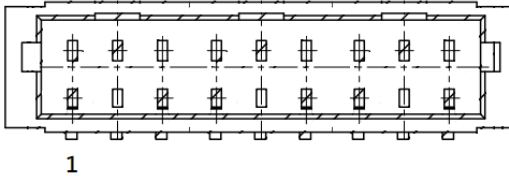

8 Wires			
Pin	Pin Name	Signal Type	Signal level
1	GND	GND	
2	TOP EXCITE	IN	
3	BOTTOM EXCITE	IN	
4	LEFT EXCITE	IN	
5	RIGHT EXCITE	IN	
6	TOP SENSE	IN	
7	BOTTOM SENSE	IN	
8	LEFT SENSE	IN	
9	RIGHT SENSE	IN	

4 Wire			
Pin	Pin Name	Signal Type	Signal level
1	GND	GND	
2	TOP	IN	
3	BOTTOM	IN	
4	LEFT	IN	
5	RIGHT	IN	
6	NC		
7	NC		
8	NC		
9	NC		

5 Wires			
Pin	Pin Name	Signal Type	Signal level
1	GND	GND	
2	UL(Y)	IN	
3	UR(H)	IN	
4	LL(L)	IN	
5	LR(X)	IN	
6	SENSE(S)	IN	
7	NC		
8	NC		
9	NC		

Note: Touch mode can be set by JP2

2.4.3 Audio I/O Port (CN3)

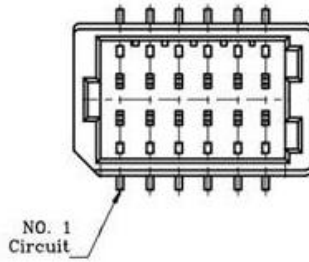

Pin	Pin Name	Signal Type	Signal level
1	LINE_R_OUT	OUT	
2	MIC_R	IN	
3	LINE_L_OUT	OUT	
4	MIC_L	IN	
5	JD_LINE OUT	IN	
6	JD_MIC IN	IN	
7	GND_AUDIO	GND	
8	GND_AUDIO	GND	
9	JD_LINE IN	IN	
10	LINE_R_IN	IN	
11	+5V_AUDIO	PWR	+5V
12	LINE_L_IN	IN	

2.4.4 Amplifier R-channel output (CN4)

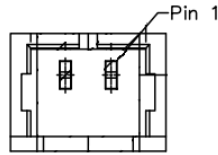

Pin	Pin Name	Signal Type	Signal level
1	SKR_R+	OUT	
2	SKR_R-	OUT	

2.4.5 Amplifier L-channel output (CN5)

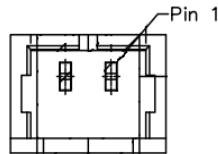

Pin	Pin Name	Signal Type	Signal level
1	SKR_L+	OUT	
2	SKR_L-	OUT	

2.4.6 M.2 Slot (B-Key 3052) (CN6)

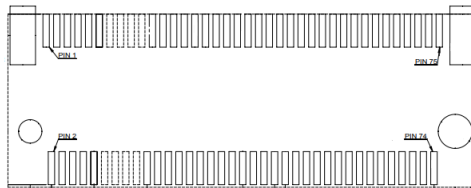

Pin	Pin Name	Signal Type	Signal level
1	GND	GND	
2	+3.3V	PWR	+3.3V

Pin	Pin Name	Signal Type	Signal level
3	GND	GND	
4	+3.3V	PWR	+3.3V
5	GND	GND	
6	N.C	N.C	
7	USB_D+	DIFF	
8	W_DISABLE	IN	
9	USB_D-	DIFF	
10	SSD_DAS#	OUT	
20	N.C	N.C	
21	GND	GND	
22	N.C	N.C	
23	N.C	N.C	
24	N.C	N.C	
25	N.C	N.C	
26	N.C	N.C	
27	GND	GND	
28	N.C	N.C	
29	USB_RX-	DIFF	
30	UIM_RST	OUT	
31	USB_RX+	DIFF	
32	UIM_CLK	OUT	
33	GND	GND	
34	UIM_DAT	IN / OUT	
35	USB_TX-	DIFF	
36	UIM_PWR	PWR	
37	USB_TX+	DIFF	

Pin	Pin Name	Signal Type	Signal level
38	DEVSLP	IN	
39	GND	GND	
40	GF_SM_CLK	OUT	
41	N.C	N.C	
42	GF_SM_DAT	IN / OUT	
43	N.C	N.C	
44	N.C	N.C	
45	GND	GND	
46	N.C	N.C	
47	N.C	N.C	
48	N.C	N.C	
49	N.C	N.C	
50	PERST#	IN	
51	GND	GND	
52	N.C	N.C	
53	N.C	N.C	
54	PEWAKE#	OUT	
55	N.C	N.C	
56	N.C	N.C	
57	GND	GND	
58	N.C	N.C	
59	N.C	N.C	
60	N.C	N.C	
61	N.C	N.C	
62	N.C	N.C	
63	N.C	N.C	

Pin	Pin Name	Signal Type	Signal level
64	N.C	N.C	
65	N.C	N.C	
66	N.C	N.C	
67	N.C	N.C	
68	N.C	N.C	
69	GND	GND	
70	+3.3V	PWR	+3.3V
71	GND	GND	
72	+3.3V	PWR	+3.3V
73	GND	GND	
74	+3.3V	PWR	+3.3V
75	N.C	N.C	

2.4.7 Nano SIM Card Socket (CN7)

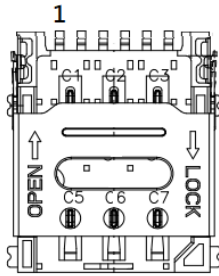

Pin	Pin Name	Signal Type	Signal level
1	UIM_PWR	PWR	
2	UIM_RST	IN	
3	UIM_CLK	IN	
4	GND	GND	
5	UIM_VPP	PWR	
6	UIM_DATA	I/O	

2.4.8 M.2 Slot (B-Key 2242) (CN8)

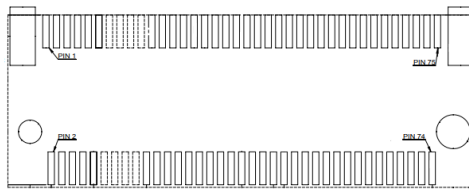

Pin	Pin Name	Signal Type	Signal level
1	GND	GND	
2	+3.3V	PWR	+3.3V
3	GND	GND	
4	+3.3V	PWR	+3.3V

Pin	Pin Name	Signal Type	Signal level
5	GND	GND	
6	N.C	N.C	
7	N.C	N.C	
8	W_DISABLE	IN	
9	N.C	N.C	
10	SSD_DAS#	OUT	
11	GND	GND	
20	N.C	N.C	
21	GND	GND	
22	N.C	N.C	
23	N.C	N.C	
24	N.C	N.C	
25	N.C	N.C	
26	N.C	N.C	
27	GND	GND	
28	N.C	N.C	
29	PCIE_RX-	DIFF	
30	N.C	N.C	
31	PCIE_RX+	DIFF	
32	N.C	N.C	
33	GND	GND	
34	N.C	N.C	
35	PCIE_TX-	DIFF	
36	N.C	N.C	
37	PCIE_TX+	DIFF	
38	DEVSLP	IN	

Pin	Pin Name	Signal Type	Signal level
39	GND	GND	
40	N.C	N.C	
41	PCIE0_RX- / SATA1_RX+	DIFF	
42	N.C	N.C	
43	PCIE0_RX+ / SATA1_RX-	DIFF	
44	N.C	N.C	
45	GND	GND	
46	N.C	N.C	
47	PCIE0_TX- / SATA1_TX-	DIFF	
48	N.C	N.C	
49	PCIE0_TX+ / SATA1_TX+	DIFF	
50	PERST#	IN	
51	GND	GND	
52	CLKREQ#	OUT	
53	PCIE_CLK-	CLK	
54	PEWAKE#	OUT	
55	PCIE_CLK+	CLK	
56	N.C	N.C	
57	GND	GND	
58	N.C	N.C	
59	N.C	N.C	
60	N.C	N.C	
61	N.C	N.C	
62	N.C	N.C	
63	N.C	N.C	
64	N.C	N.C	

Pin	Pin Name	Signal Type	Signal level
65	N.C	N.C	
66	N.C	N.C	
67	N.C	N.C	
68	N.C	N.C	
69	GND	GND	
70	+3.3V	PWR	+3.3V
71	GND	GND	
72	+3.3V	PWR	+3.3V
73	GND	GND	
74	+3.3V	PWR	+3.3V
75	N.C	N.C	

Note: The speed of PCIe for CN8 can be changed by BIOS and be changed to mSATA by BOM.

Default: PCIe x2

2.4.9 LVDS/eDP Port Inverter / Backlight Connector (CN9)

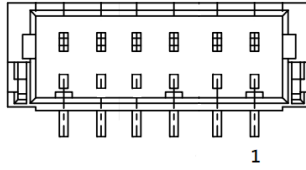

Pin	Pin Name	Signal Type	Signal level
1	BKL_PWR	PWR	+5V / +12V
2	BKL_PWR	PWR	+5V / +12V
3	BKL_CONTROL	OUT	
4	GND	GND	
5	GND	GND	
6	BKL_ENABLE	OUT	+5V

Note1: LVDS BKL_PWR can be set to +5V or +12V by JP3

Note2: LVDS BKL_CONTROL can be set by JP5

2.4.10 LVDS/eDP Port (CN10)

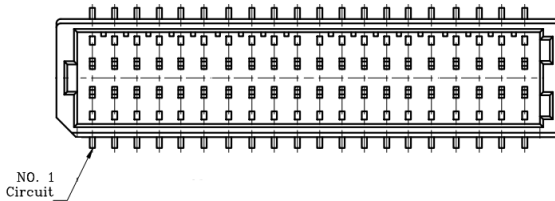

LVDS Function

Pin	Pin Name	Signal Type	Signal level
1	BKL_ENABLE	OUT	
2	BKL_CONTROL	OUT	
3	GND	GND	
4	GND	GND	

Pin	Pin Name	Signal Type	Signal level
5	LVDS_A_CLK- / EDP_LANE 3-	DIFF	
6	LCD_PWR	PWR	+3.3V/+5V
7	LVDS_A_CLK+ / EDP_LANE 3+	DIFF	
8	LCD_PWR	PWR	+3.3V/+5V
9	GND	GND	
10	GND	GND	
11	LVDS_DA0- / EDP_LANE 2-	DIFF	
12	LVDS_DA2- / EDP_LANE 0-	DIFF	
13	LVDS_DA0+ / EDP_LANE 2+	DIFF	
14	LVDS_DA2+ / EDP_LANE 0+	DIFF	
15	GND	GND	
16	GND	GND	
17	LVDS_DA1- / EDP_LANE 1-	DIFF	
18	LVDS_DA3-	DIFF	
19	LVDS_DA1+ / EDP_LANE 1+	DIFF	
20	LVDS_DA3+	DIFF	
21	GND	GND	
22	GND	GND	
23	LVDS_DB0-	DIFF	
24	DDC_DATA / EDP_AUX-	I/O / DIFF	+3.3V
25	LVDS_DB0+	DIFF	
26	DDC_CLK / EDP_AUX+	I/O / DIFF	+3.3V
27	GND	GND	
28	GND	GND	
29	LVDS_DB1-	DIFF	
30	LVDS_DB2-	DIFF	

Pin	Pin Name	Signal Type	Signal level
31	LVDS_DB1+	DIFF	
32	LVDS_DB2+	DIFF	
33	GND	GND	
34	GND	GND	
35	LVDS_B_CLK-	DIFF	
36	LVDS_DB3-	DIFF	
37	LVDS_B_CLK+	DIFF	
38	LVDS_DB3+	DIFF	
39	eDP HPD	IN	+3.3V
40	N.C	N.C	

Note: LVDS LCD_PWR can be set to +3.3V or +5V by JP4

2.4.11 HDMI (CN11)

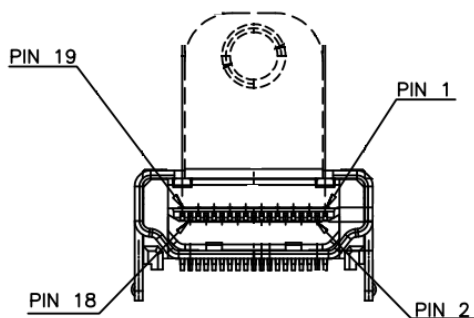

Pin	Pin Name	Signal Type	Signal level
1	HDMI_D2+	DIFF	
2	GND	GND	
3	HDMI_D2-	DIFF	
4	HDMI_D1+	DIFF	

Pin	Pin Name	Signal Type	Signal level
5	GND	GND	
6	HDMI_D1-	DIFF	
7	HDMI_D0+	DIFF	
8	GND	GND	
9	HDMI_D0-	DIFF	
10	HDMI_CLK+	DIFF	
11	GND	GND	
12	HDMI_CLK-	DIFF	
13	N.C	N.C	
14	N.C	N.C	
15	HDMI_SLK	CLK	
16	HDMI_SDA	IN/OUT	
17	GND	GND	
18	+5V	I/O	+5V
19	HPLG_DETECT	IN	

2.4.12 DP Port (CN13)

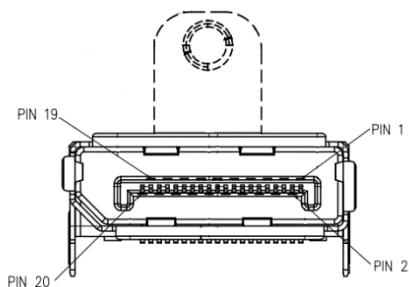

Pin	Pin Name	Signal Type	Signal level
1	DP_D0+	DIFF	

Pin	Pin Name	Signal Type	Signal level
2	GND	GND	
3	DP_D0-	DIFF	
4	DP_D1+	DIFF	
5	GND	GND	
6	DP_D1-	DIFF	
7	DP_D2+	DIFF	
8	GND	GND	
9	DP_D2-	DIFF	
10	DP_D3+	DIFF	
11	GND	GND	
12	DP_D3-	DIFF	
13	DDI2_OB_AUX_EN	IN	
14	GND	GND	
15	DP_AUX+ / DDI2_CTRL_CLK	DIFF	
16	GND	GND	
17	DP_AUX- / DDI2_CTRL_DATA	DIFF	
18	HPLG_DETECT	IN	
19	GND	GND	
20	+3.3V	I/O	+3.3V

2.4.13 LAN (RJ-45) Port1 (CN14)

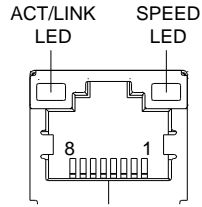

Pin	Pin Name	Signal Type	Signal level
1	MDI0+	DIFF	
2	MDI0-	DIFF	
3	MDI1+	DIFF	
4	MDI2+	DIFF	
5	MDI2-	DIFF	
6	MDI1-	DIFF	
7	MDI3+	DIFF	
8	MDI3-	DIFF	

2.4.14 LAN (RJ-45) Port2 (CN15)

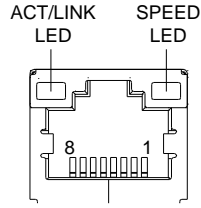

Pin	Pin Name	Signal Type	Signal level
1	MDI0+	DIFF	
2	MDI0-	DIFF	
3	MDI1+	DIFF	
4	MDI2+	DIFF	
5	MDI2-	DIFF	
6	MDI1-	DIFF	
7	MDI3+	DIFF	
8	MDI3-	DIFF	

2.4.15 SATA Port (CN16)

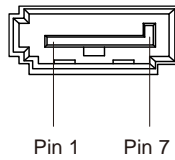

Pin	Pin Name	Signal Type	Signal level
1	GND	GND	
2	SATA_TX+	DIFF	
3	SATA_TX-	DIFF	
4	GND	GND	
5	SATA_RX-	DIFF	

Pin	Pin Name	Signal Type	Signal level
6	SATA_RX+	DIFF	
7	GND	GND	

2.4.16 +5V Output for SATA HDD (CN17)

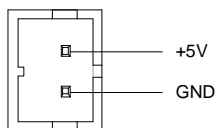

Pin	Pin Name	Signal Type	Signal level
1	+5V	PWR	+5V
2	GND	GND	

2.4.17 Digital IO Port (CN18)

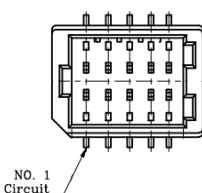

Pin	Pin Name	Signal Type	Signal level
1	+5V	PWR	+5V
2	DIO1	I/O	+5V
3	DIO0	I/O	+5V
4	DIO3	I/O	+5V
5	DIO2	I/O	+5V
6	DIO5	I/O	+5V
7	DIO4	I/O	+5V

Pin	Pin Name	Signal Type	Signal level
8	DIO7	I/O	+5V
9	DIO6	I/O	+5V
10	GND	GND	

2.4.18 Digital IO Port (CN19)

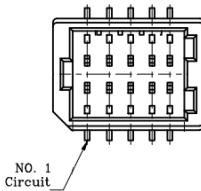

Pin	Pin Name	Signal Type	Signal level
1	+5V	PWR	+5V
2	DIO9	I/O	+5V
3	DIO8	I/O	+5V
4	DIO11	I/O	+5V
5	DIO10	I/O	+5V
6	DIO13	I/O	+5V
7	DIO12	I/O	+5V
8	DIO15	I/O	+5V
9	DIO14	I/O	+5V
10	GND	GND	

2.4.19 USB 3.1 Ports (CN20)

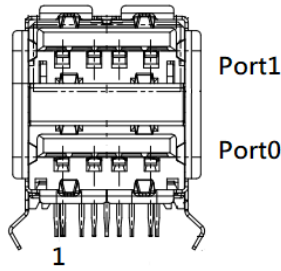

Pin	Pin Name	Signal Type	Signal level
1	+5VSB	PWR	+5V
2	USB_D-	DIFF	
3	USB_D+	DIFF	
4	GND	GND	
5	USB_SSRX-	DIFF	
6	USB_SSRX+	DIFF	
7	GND	GND	
8	USB_SSTX-	DIFF	
9	USB_SSTX+	DIFF	
10	+5VSB	PWR	+5V
11	USB_D-	DIFF	
12	USB_D+	DIFF	
13	GND	GND	
14	USB_SSRX-	DIFF	
15	USB_SSRX+	DIFF	
16	GND	GND	
17	USB_SSTX-	DIFF	
18	USB_SSTX+	DIFF	

2.4.20 USB 2.0 Port (CN21)

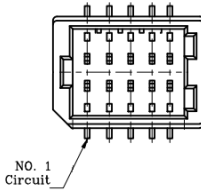

Pin	Pin Name	Signal Type	Signal level
1	+5VSB	PWR	+5V
2	+5VSB	PWR	+5V
3	USB_D0-	DIFF	
4	USB_D1-	DIFF	
5	USB_D0+	DIFF	
6	USB_D1+	DIFF	
7	GND	GND	
8	GND	GND	
9	GND	GND	
10	GND	GND	

2.4.21 USB 2.0 Port (CN22)

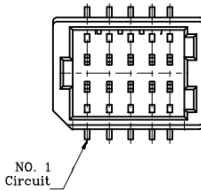

Pin	Pin Name	Signal Type	Signal level
1	+5VSB	PWR	+5V
2	+5VSB	PWR	+5V

Pin	Pin Name	Signal Type	Signal level
3	USB_D0-	DIFF	
4	USB_D1-	DIFF	
5	USB_D0+	DIFF	
6	USB_D1+	DIFF	
7	GND	GND	
8	GND	GND	
9	GND	GND	
10	GND	GND	

2.4.22 M.2 Slot (B-Key 2280) (CN25)

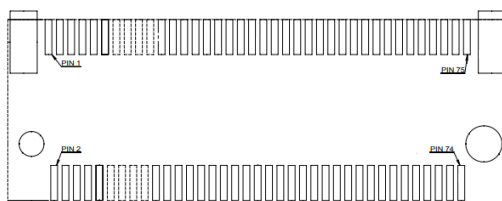

Pin	Pin Name	Signal Type	Signal level
1	GND	GND	
2	+3.3V	PWR	+3.3V
3	GND	GND	
4	+3.3V	PWR	+3.3V
5	GND	GND	
6	N.C	N.C	
7	USB_D8+	DIFF	
8	W_DISABLE	IN	
9	USB_D8-	DIFF	
10	SSD_DAS#	OUT	

Pin	Pin Name	Signal Type	Signal level
11	GND	GND	
20	N.C	N.C	
21	GND	GND	
22	N.C	N.C	
23	N.C	N.C	
24	N.C	N.C	
25	N.C	N.C	
26	N.C	N.C	
27	GND	GND	
28	N.C	N.C	
29	PCIE7_RX-	DIFF	
30	N.C	N.C	
31	PCIE7_RX+	DIFF	
32	N.C	N.C	
33	GND	GND	
34	N.C	N.C	
35	PCIE7_TX-	DIFF	
36	N.C	N.C	
37	PCIE7_TX+	DIFF	
38	N.C	N.C	
39	GND	GND	
40	N.C	N.C	
41	PCIE6_RX-	DIFF	
42	N.C	N.C	
43	PCIE6_RX+	DIFF	
44	N.C	N.C	

Pin	Pin Name	Signal Type	Signal level
45	GND	GND	
46	N.C	N.C	
47	PCIE6_TX-	DIFF	
48	N.C	N.C	
49	PCIE6_TX+	DIFF	
50	PERST#	IN	
51	GND	GND	
52	CLKREQ#	OUT	
53	PCIE1_CLK-	CLK	
54	PEWAKE#	OUT	
55	PICE1_CLK+	CLK	
56	N.C	N.C	
57	GND	GND	
58	N.C	N.C	
59	N.C	N.C	
60	N.C	N.C	
61	N.C	N.C	
62	N.C	N.C	
63	N.C	N.C	
64	N.C	N.C	
65	N.C	N.C	
66	N.C	N.C	
67	N.C	N.C	
68	N.C	N.C	
69	GND	GND	
70	+3.3V	PWR	+3.3V

Pin	Pin Name	Signal Type	Signal level
71	GND	GND	
72	+3.3V	PWR	+3.3V
73	GND	GND	
74	+3.3V	PWR	+3.3V
75	N.C	N.C	

Note: The speed of PCIe for CN25 can be changed by BIOS.

Default: PCIe x1

2.4.23 M.2 Slot (E-Key 2230) (CN26)

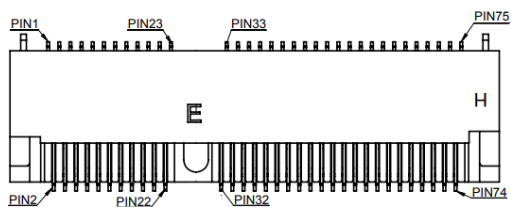

Pin	Pin Name	Signal Type	Signal level
1	GND	GND	
2	+3.3V	PWR	+3.3V
3	USB_D+	DIFF	
4	+3.3V	PWR	+3.3V
5	USB_D-	DIFF	
6	NC	NC	
7	GND	GND	
8	BT_PCM_CLK	NC	
9	NC	NC	
10	BT_PCM_FRM_CRF_RST	NC	

Pin	Pin Name	Signal Type	Signal level
11	NC	NC	
12	BT_PCM_IN	NC	
13	NC	NC	
14	BT_PCM_OUT_CLKREQ	NC	
15	NC	NC	
16	NC	NC	
17	NC	NC	
18	GND	GND	
19	NC	NC	
20	NC	NC	
21	NC	NC	
22	NC	NC	
23	NC	NC	
32	NC	NC	
33	GND	GND	
34	NC	NC	
35	PCIE1_TX+	DIFF	
36	NC	NC	
37	PCIE1_TX-	DIFF	
38	NC	NC	
39	GND	GND	
40	NC	NC	
41	PCIE1_RX+	DIFF	
42	NC	NC	
43	PCIE1_RX-	DIFF	
44	NC	NC	

Pin	Pin Name	Signal Type	Signal level
45	GND	GND	
46	N.C	N.C	
47	PCIE0_CLK+	DIFF	
48	N.C	N.C	
49	PCIE0_CLK-	DIFF	
50	NC	NC	
51	GND	GND	
52	RESET#	IN	3.3V
53	PCIE_CLKREQ#	OUT	
54	BT_EN	IN	3.3V
55	PCIE_WAKE#	OUT	3.3V
56	WIFI_EN	IN	3.3V
57	GND	GND	
58	I2C_DATA	IN / OUT	3.3V
59	N.C	N.C	
60	I2C_CLK	IN	3.3V
61	N.C	N.C	
62	ALERT#	N.C	3.3V
63	GND	GND	
64	N.C	N.C	
65	N.C	N.C	
66	N.C	N.C	
67	N.C	N.C	
68	N.C	N.C	
69	GND	GND	
70	N.C	N.C	

Pin	Pin Name	Signal Type	Signal level
71	N.C	N.C	
72	+3.3V	PWR	+3.3V
73	N.C	N.C	
74	+3.3V	PWR	+3.3V
75	GND	GND	

2.4.24 COM Port 1~4 (CN27)

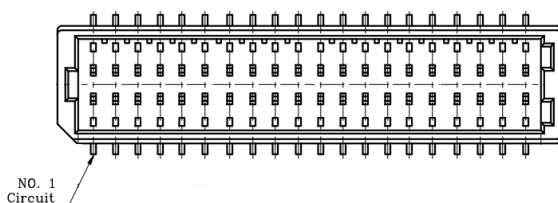

RS-232/422/485

Pin	Pin Name	Signal Type	Signal level
1	COM1 : DCD / RS422_TX-/ RS485_D-	IN / OUT	±5V
2	COM2 : DCD / RS422_TX-/ RS485_D-	IN / OUT	±5V
3	COM1: RX / RS422_TX+ / RS485_D+	IN / OUT	±5V
4	COM2: RX / RS422_TX+ / RS485_D+	IN / OUT	±5V
5	COM1: TX / RS422_RX+	OUT / IN	±5V
6	COM2: TX / RS422_RX+	OUT / IN	±5V
7	COM1: DTR / RS422_RX-	OUT / IN	±5V
8	COM2: DTR / RS422_RX-	OUT / IN	±5V
9	COM1: GND	GND	
10	COM2: GND	GND	
11	COM1: DSR	IN	
12	COM2: DSR	IN	

Pin	Pin Name	Signal Type	Signal level
13	COM1: RTS	OUT	±5V
14	COM2: RTS	OUT	±5V
15	COM1: CTS	IN	
16	COM2: CTS	IN	
17	COM1: RI	IN/ PWR	+5V/+12V
18	COM2: RI/+5V/+12V	IN/ PWR	+5V/+12V
19	N.C	N.C	
20	N.C	N.C	
21	COM3 : DCD / RS422_TX- / RS485_D-	IN / OUT	±5V
22	COM4 : DCD / RS422_TX- / RS485_D-	IN / OUT	±5V
23	COM3: RX / RS422_TX+ / RS485_D+	IN / OUT	±5V
24	COM4: RX / RS422_TX+ / RS485_D+	IN / OUT	±5V
25	COM3: TX / RS422_RX+	OUT / IN	±5V
26	COM4: TX / RS422_RX+	OUT / IN	±5V
27	COM3: DTR / RS422_RX-	OUT / IN	±5V
28	COM4: DTR / RS422_RX-	OUT / IN	±5V
29	COM3: GND	GND	
30	COM4: GND	GND	
31	COM3: DSR	IN	
32	COM4: DSR	IN	
33	COM3: RTS	OUT	±5V
34	COM4: RTS	OUT	±5V
35	COM3: CTS	IN	
36	COM4: CTS	IN	
37	COM3: RI/+5V/+12V	IN/ PWR	+5V/+12V
38	COM4: RI	IN/ PWR	+5V/+12V

Pin	Pin Name	Signal Type	Signal level
39	N.C	N.C	
40	N.C	N.C	

2.4.25 eSPI Debug Port (CN32)

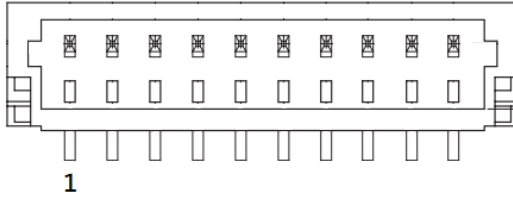

Pin	Pin Name	Signal Type	Signal level
1	ESPI_IO0	I/O	+1.8V
2	ESPI_IO1	I/O	+3.3V
3	ESPI_IO2	I/O	+3.3V
4	ESPI_IO3	I/O	+3.3V
5	+3.3V	PWR	+3.3V
6	ESPI_CS#	IN	
7	ESPI_RST#	OUT	+3.3V
8	GND	GND	
9	ESPI_CLK	OUT	
10	+3.3V	PWR	+3.3V

2.4.26 CPU FAN (CN33)

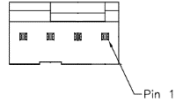

Pin	Pin Name	Signal Type	Signal level
1	GND	GND	
2	FAN_POWER	PWR	+12V
3	FAN_TAC	IN	
4	FAN_CTL	OUT	

2.4.27 External Power Input (CN34)

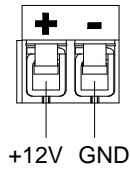

Pin	Pin Name	Signal Type	Signal level
1	+12V	PWR	+9~+36V (or +12V)
2	GND	GND	

2.4.28 External Power Input (CN35)

Pin	Pin Name	Signal Type	Signal level
1	GND	GND	
2	GND	GND	
3	+12V	PWR	+9~+36V (or +12V)
4	+12V	PWR	+9~+36V (or +12V)

2.4.29 Front Panel Connector (CN36)

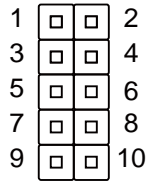

Pin	Function	Pin	Function
1	PWR_BTN-	2	PWR_BTN+
3	HDD_LED-	4	HDD_LED+
5	SPEAKER-	6	SPEAKER+
7	PWR_LED-	8	PWR_LED+
9	H/W RESET-	10	H/W RESET+

2.4.30 PSE Connector (CN37)

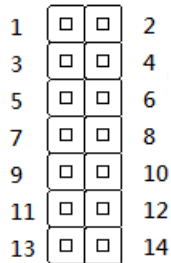

Pin	Pin Name	Signal Type	Signal level
1	PSE_POWER	PWR	1.8V / 3.3V
2	PSE_TRACE_CLK	OUT	
3	PSE_SW_DIO		
4	PSE_TRACE_DATA0	IN/ OUT	
5	PSE_SW_CLK		
6	PSE_TRACE_DATA1	IN/ OUT	

Pin	Pin Name	Signal Type	Signal level
7	PSE_TRACE_SWO		
8	PSE_TRACE_DATA2	IN/ OUT	
9	RESET#	OUT	
10	PSE_TRACE_DATA3	IN/ OUT	
11	UART_TX	OUT	
12	GND	GND	
13	UART_RX	IN	
14	N.C	N.C	

2.4.31 CAN BUS (CN38)

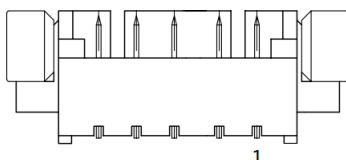

Pin	Pin Name	Signal Type	Signal level
1	CAN_BUS_0_H	IN / OUT	
2	CAN_BUS_0_L	IN / OUT	
3	GND	GND	
4	CAN_BUS_1_H	IN / OUT	
5	CAN_BUS_1_L	IN / OUT	

2.4.32 VGA Port (CN39)

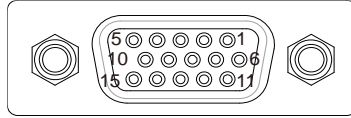

Pin	Pin Name	Signal Type	Signal level
1	RED	OUT	
2	GREEN	OUT	
3	BLUE	OUT	
4	NC		
5	GND	GND	
6	RED_GND_RTN	GND	
7	GREEN_GND_RTN	GND	
8	BLUE_GND_RTN	GND	
9	+5V	PWR	+5V
10	GND	GND	
11	NC		
12	DDC_DATA	I/O	+5V
13	HSYNC	OUT	
14	VSYNC	OUT	
15	DDC_CLK	I/O	+5V

2.4.33 LAN1 SDP Connector (CN43)

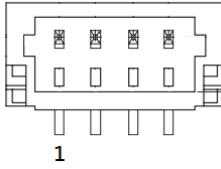

Pin	Pin Name	Signal Type	Signal level
1	SDP0	IN / OUT	
2	SDP0	IN / OUT	
3	SDP0	IN / OUT	
4	SDP0	IN / OUT	

2.4.34 LAN2 SDP Connector (CN44)

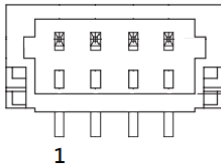

Pin	Pin Name	Signal Type	Signal level
1	SDP0	IN / OUT	
2	SDP0	IN / OUT	
3	SDP0	IN / OUT	
4	SDP0	IN / OUT	

2.4.35 DDR4 SO-DIMM (DIMM1)

Standard Version

2.5 Thermal Solution

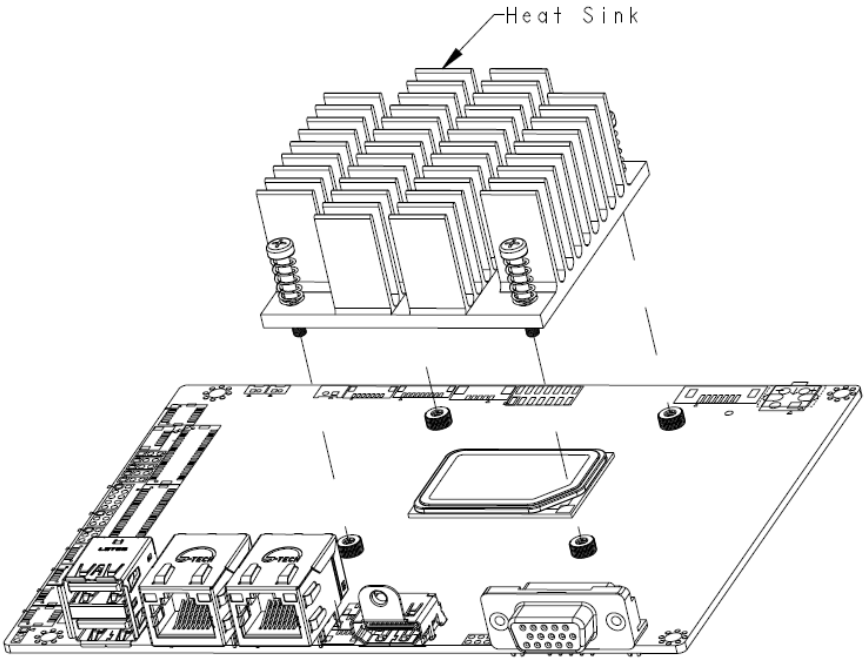

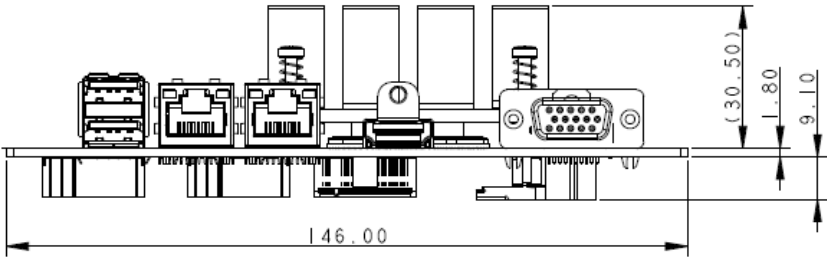
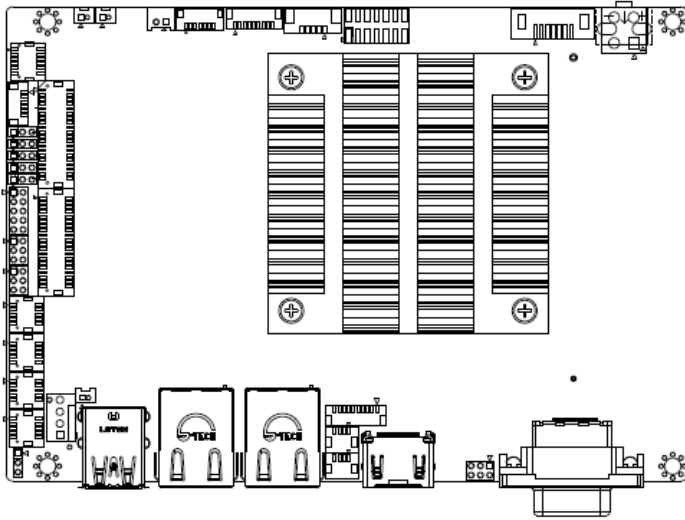

2.6 Electrical Specifications for I/O Port

I/O	Reference	Signal Name	Rate Output
Audio I/O Port	CN3	+5V	+5V/0.5A
M.2 B-Key 3052	CN6	+3.3VSB	+3.3V/2.0A
M.2 B-Key 2242	CN8	+3.3VSB	+3.3V/1.5A
LVDS / eDP Port Inverter / Backlight Connector	CN9	+5V/+12V	+5V/2.0A or +12V/2.0A
LVDS /eDP Port	CN10	+3.3V/+5V	+3.3V/1.5A or +5V/1.5A
HDMI port	CN11	+5V	+5V/0.5A
DP port	CN13	+3.3V	+3.3V/1.0A
+5V Output for SATA HDD	CN17	+5V	+5V/1.5A
Digital IO Port	CN18	+5V	+5V/0.5A
Digital IO Port	CN19	+5V	+5V/0.5A
USB 3.1 Ports	CN20	+5VSB	+5V/0.9A (per channel)
USB 2.0 Ports	CN21	+5VSB	+5V/0.5A (per channel)
USB 2.0 Ports	CN22	+5VSB	+5V/0.5A (per channel)
M.2 B-Key 2280	CN25	+3.3VSB	+3.3V/1.5A
M.2 E-Key 2230	CN26	+3.3VSB	+3.3V/1.5A
COM Port 2 / 3	CN27	+5V/+12V	+5V/0.5A or +12V/0.5A (per channel)
eSPI Debug Port	CN32	+3.3V	+3.3V/0.5A
CPU FAN	CN33	+12V	+12V/1.0A
VGA port	CN39	+5V	+5V/1.0A

Chapter 3

AMI BIOS Setup

3.1 System Test and Initialization

The GENE-CML5 board uses certain routines to perform testing and initialization during the boot up sequence. If an error, fatal or non-fatal, is encountered, the module will output a few short beeps or display an error message. The module can usually continue the boot up sequence with non-fatal errors.

The system configuration verification routines check the current system configuration against the values stored in the CMOS memory and BIOS NVRAM. If a system configuration is not found or an error is detected, the module will load the default configuration and reboot automatically.

There are four situations in which you will need to setup system configuration:

1. You are starting your system for the first time
2. You have changed the hardware attached to your system
3. The system configuration was reset by the Clear-CMOS jumper
4. The CMOS memory has lost power and the configuration information has been erased.

The system CMOS memory has an integral lithium battery backup for data retention.

You will need to replace the battery unit when it runs down.

3.2 AMI BIOS Setup

The AMI BIOS ROM has a pre-installed Setup program that allows users to modify basic system configurations, which is stored in the battery-backed CMOS RAM and BIOS NVRAM so that the information is retained when the power is turned off.

To enter BIOS Setup, press or <ESC> immediately while your computer is powering up.

The function for each interface can be found below.

Main – Date and time can be set here. Press <Tab> to switch between date elements

Advanced – Access hardware monitor and advanced board features, options

Chipset – Host bridge parameters

Boot – Enable/ Disable Quiet Boot option

Security – The setup administrator password can be set here

Save & Exit – Save your changes and exit the program

3.3 Setup Submenu: Main



3.4 Setup Submenu: Advanced

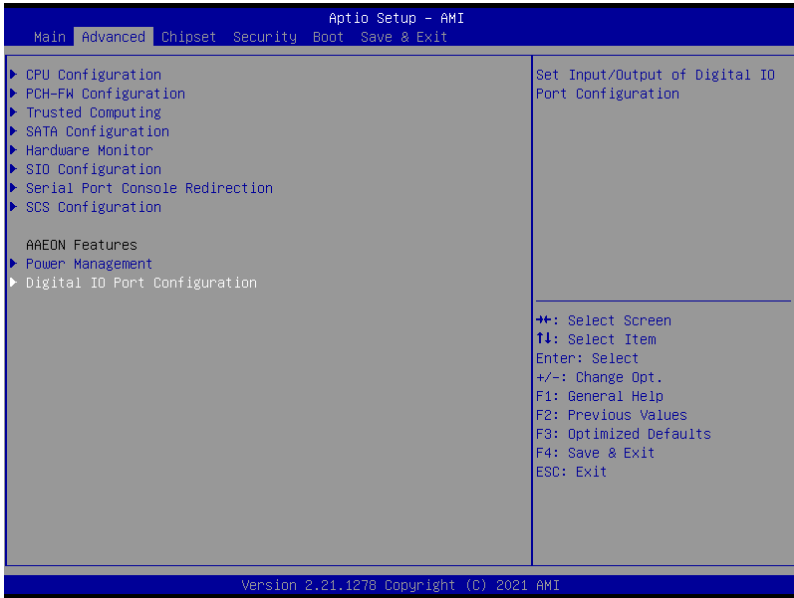

3.4.1 CPU Configuration

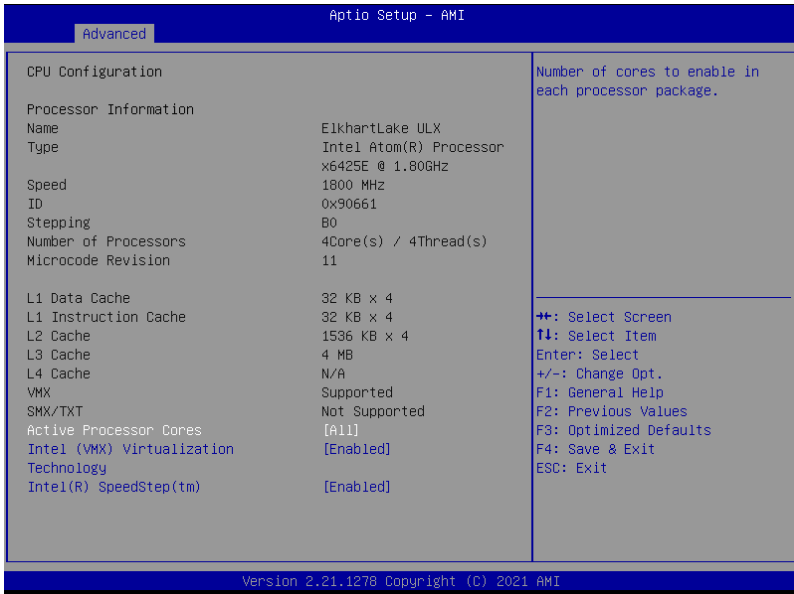

Options summary:

Active Processor	All	Optimal Default, Failsafe Default
Cores	1~N	
Number of cores to enable in each processor package.		
Intel (VMX)	Disabled	
Virtualization Technology	Enabled	Optimal Default, Failsafe Default
When enabled, a VMM can utilize the additional hardware capabilities provided by Vanderpool Technology.		
Intel® SpeedStep™	Disabled	
	Enabled	Optimal Default, Failsafe Default
Allows more than two frequency ranges to be supported.		

3.4.2 PCH-FW Configuration

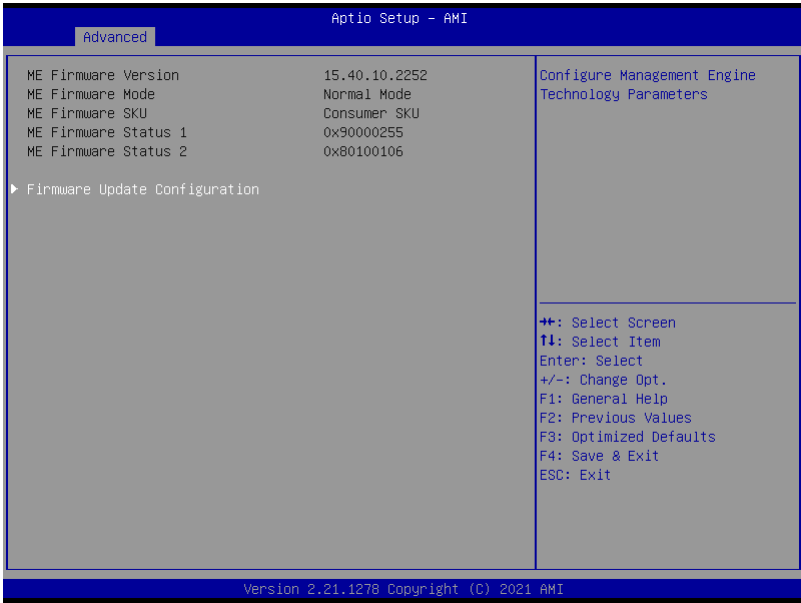

3.4.2.1 Firmware Update Configuration

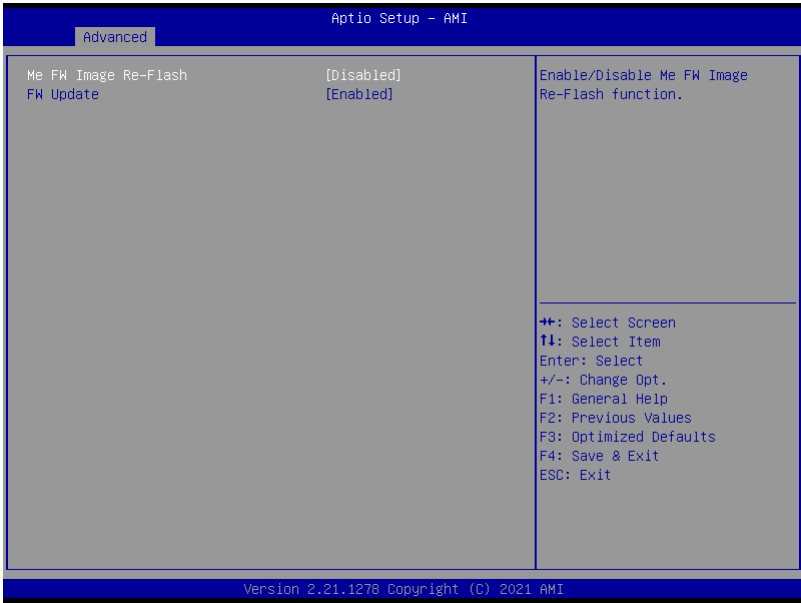

Options summary:

Me FW Image	Enabled	
Re-Flash	Disabled	Optimal Default, Failsafe Default
Enable/Disable Me FW Image Re-Flash function.		
FW Update	Disabled	
	Enabled	Optimal Default, Failsafe Default
Enable/Disable ME FW Update function.		

3.4.3 Trusted Computing

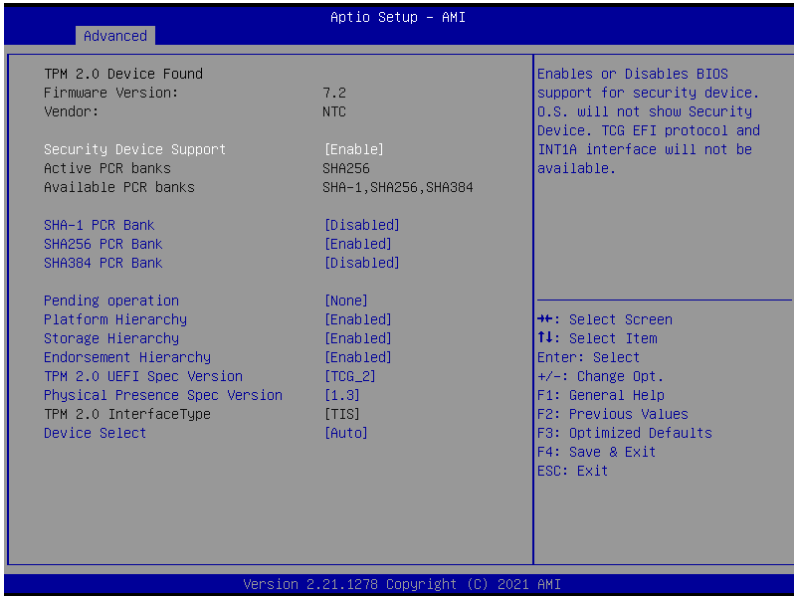

Options summary:

Security Deice Support	Enable	Optimal Default, Failsafe Default
	Disable	
Enables or Disables BIOS support for security device. O.S. will not show Security Device. TCG EFI protocol and INT1A interface will not be available.		
SHA-1 PCR Bank	Disabled	Optimal Default, Failsafe Default
	Enabled	
Enable or Disable SHA-1 PCR Bank		
SHA256 PCR Bank	Enabled	Optimal Default, Failsafe Default
	Disabled	
Enable or Disable SHA256 PCR Bank.		
SHA384 PCR Bank	Enabled	Optimal Default, Failsafe Default
	Disabled	

Enable or Disable SHA384 PCR Bank.		
SM3_256 PCR Bank	Enabled	Optimal Default, Failsafe Default
	Disabled	
Enable or Disable SM3_256 PCR Bank		
Pending operation	None	Optimal Default, Failsafe Default
	TPM Clear	
Schedule an Operation for the Security Device. NOTE: Your Computer will reboot during restart in order to change State of Security Device.		
Platform Hierarchy	Enabled	Optimal Default, Failsafe Default
	Disabled	
Enable or Disable Platform Hierarchy		

Storage Hierarchy	Enabled	Optimal Default, Failsafe Default
	Disabled	
Enable or Disable Storage Hierarchy		
Endorsement Hierarchy	Enabled	Optimal Default, Failsafe Default
	Disabled	
Enable or Disable Endorsement Hierarchy		
TPM 2.0 UEFI Spec Version	TCG_2	Optimal Default, Failsafe Default
	TCG_1_2	
Select the TCH2 Spec Version Support. TCG_1_2: the Compatible mode for Win8/Win10 TCG_2: Support new TCG2 protocol and event format for Win10 or later		
Physical Presence Spec Version	1.3	Optimal Default, Failsafe Default
	1.2	
Select to Tell O.S. to support PPI Spec Version 1.2 or 1.3. Note some HCK tests might not support 1.3		

Device Select	Auto	Optimal Default, Failsafe Default
	TPM 1.2	
	TPM 2.0	

TPM 1.2 will restrict support to TPM 1.2 devices, TPM 2.0 will restrict support to TPM 2.0 devices, Auto will support both with the default set to TPM 2.0 devices if not found, TPM 1.2 devices will be enumerated.

3.4.4 SATA Configuration

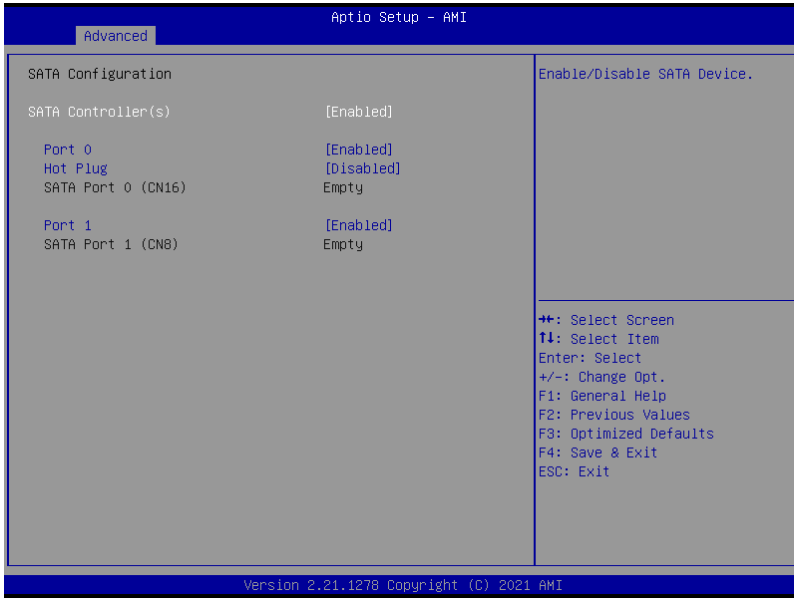

Options summary:

SATA Controller(s)	Enabled	Optimal Default, Failsafe Default
	Disabled	
Enable/Disable SATA Device.		
Port*	Enabled	Optimal Default, Failsafe Default
	Disabled	
Enable or Disable SATA Port.		

3.4.5 Hardware Monitor

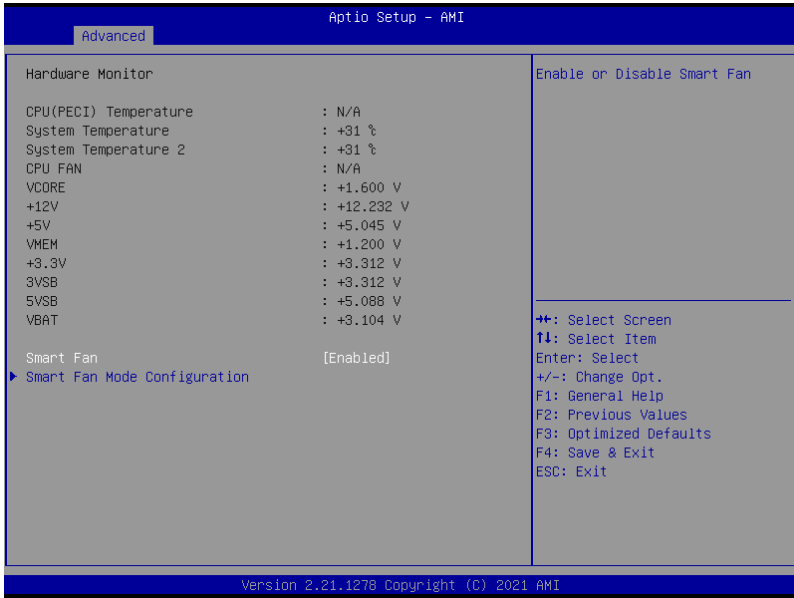

Options summary:

Smart Fan	Disable	
	Enable	Optimal Default, Failsafe Default
Enables or Disables Smart Fan.		

3.4.5.1 Smart Fan Mode Configuration

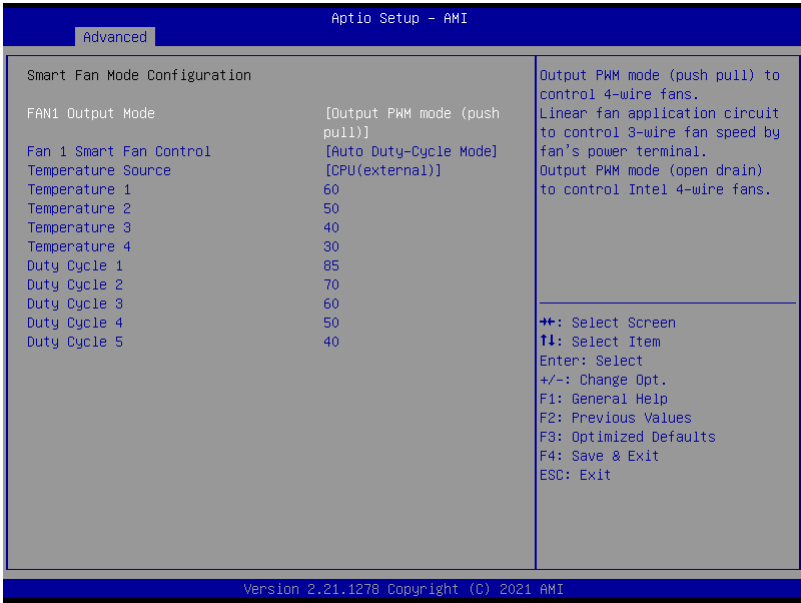

Options summary:

FAN1 Output Mode	Output PWM mode (open drain)	
	Linear Fan Application	
	Output PWM mode (push pull)	Optimal Default, Failsafe Default
Fan 1 Smart Fan Control	Manual Duty Mode	
	Auto Duty-Cycle Mode	Optimal Default, Failsafe Default
Smart Fan Mode Select		
Temperature Source	CPU(PECI) Temperature	
	System Temperature	Optimal Default, Failsafe Default
	System Temperature 2	
Select the monitored temperature source for this fan.		

Temperature 1	60	
Duty Cycle 1	85	
Auto fan speed control. Fan speed will follow different temperature by different duty cycle 1-100		

3.4.6 SIO Configuration



3.4.6.1 Serial Port Configuration



Options summary:

Use This Device	Disable	
	Enable	Optimal Default, Failsafe Default
Enable or Disable this Logical Device.		
Possible:	Use Automatic Settings	Optimal Default, Failsafe Default
	IO=3F8h; IRQ=4	
	IO=2F8h; IRQ=3	
Allows user to change Device's Resource settings. New settings will be reflected on This Setup Page after System restarts.		
Mode:	RS232	Optimal Default, Failsafe Default
	RS422	
	RS485	
UART RS232, 422, 485 selection.		

3.4.7 Serial Port Console Redirection

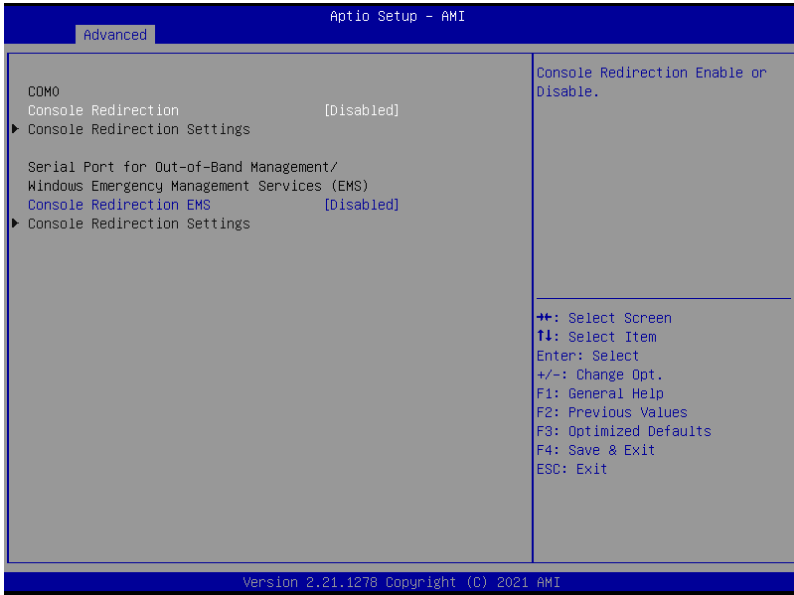

Options summary:

Console Redirection	Disabled	Optimal Default, Failsafe Default
	Enabled	
Console Redirection Enable or Disable.		
Console Redirection	Disabled	Optimal Default, Failsafe Default
EMS	Enabled	
Console Redirection Enable or Disable.		

3.4.8 SCS Configuration

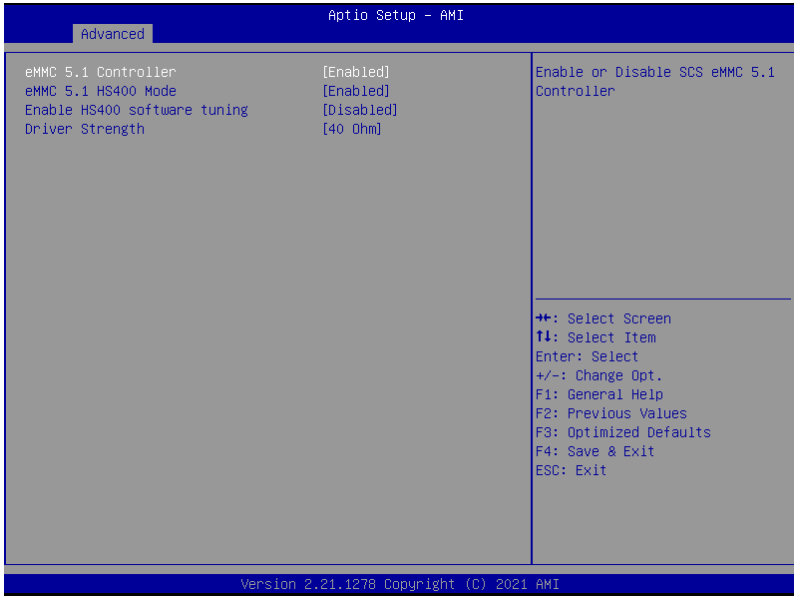

eMMC 5.1 Controller	Disabled	
	Enabled	Optimal Default, Failsafe Default
Enable or Disable SCS eMMC 5.1 Controller.		
eMMC 5.1 HS400 Mode	Disabled	
	Enabled	Optimal Default, Failsafe Default
Enable or Disable SCS eMMC 5.1 HS400 Mode		
Enable HS400 software tuning	Disabled	Optimal Default, Failsafe Default
	Enabled	
Software tuning should improve eMMC HS400 stability at the expense of boot time		
Driver Strength	33 Ohm	
	40 Ohm	Optimal Default, Failsafe Default
	50 Ohm	
Sets I/O driver strength		

3.4.9 Power Management

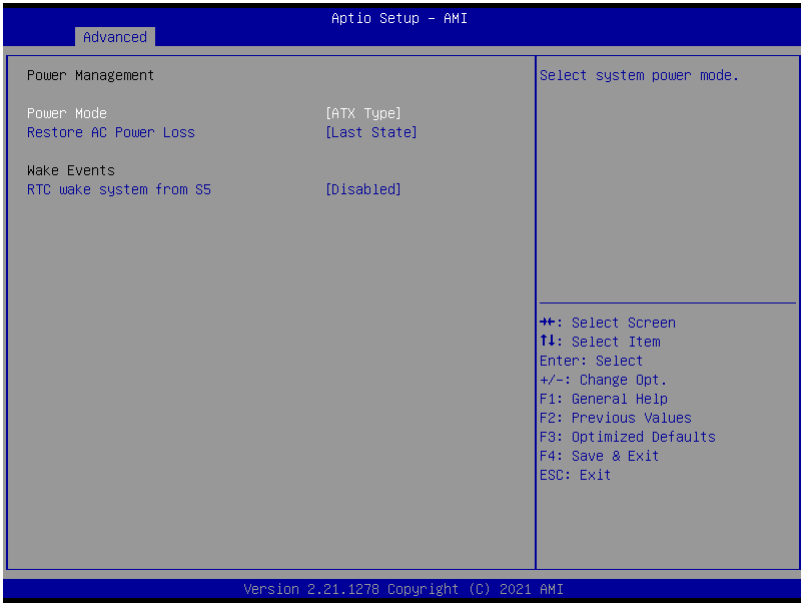

Options summary:

Power Mode	ATX Type	Optimal Default, Failsafe Default
	AT Type	
Select power supply mode.		
Restore AC Power Loss	Last State	Optimal Default, Failsafe Default
	Always On	
	Always Off	
Select power state when power is re-applied after a power failure.		
RTC wake system from S5	Disable	Optimal Default, Failsafe Default
	Fixed Time	
Fixed Time: System will wake on the hr::min::sec specified./n Dynamic Time: System will wake on the current time + Increase minute(s)		

3.4.10 Digital IO Port Configuration

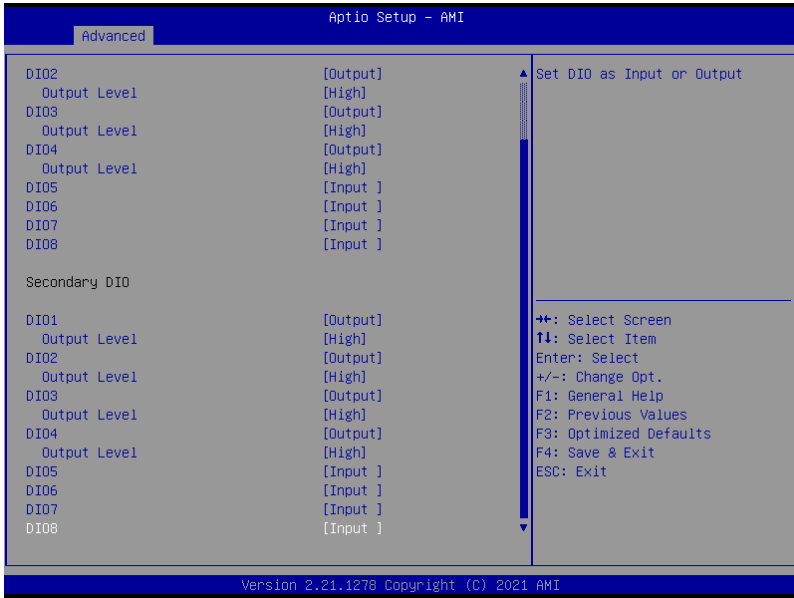

Options summary:

DIO Port*	Output	
	Input	
Set DIO as Input or Output		
Output Level	High	
	Low	
Set output level when DIO pin is output		

3.5 Setup Submenu: Chipset



3.5.1 System Agent (SA) Configuration



Options summary:

VT-d	Disabled	
	Enabled	Optimal Default, Failsafe Default
VT-d capability		

3.5.1.1 Memory Configuration

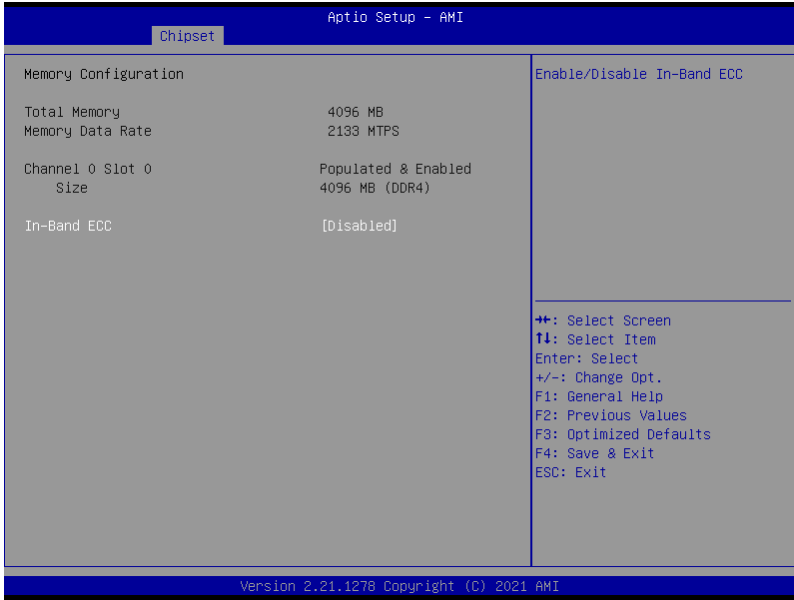

Options summary:

In-Band ECC	Disabled	Optimal Default, Failsafe Default
	Enabled	
Enable/Disable In-Band ECC		

3.5.1.2 LVDS Panel Configuration

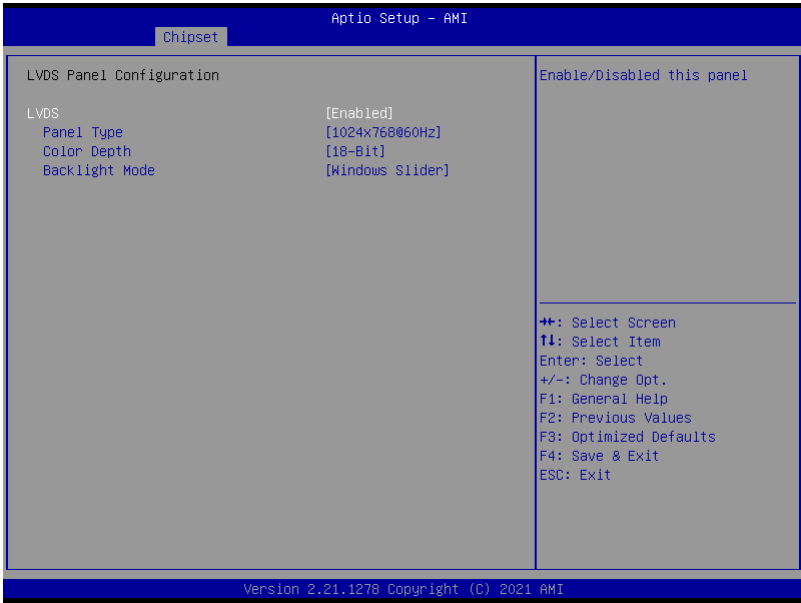

Options summary:

LVDS	Disabled	Optimal Default, Failsafe Default
	Enabled	
Enable/Disabled this panel.		
LVDS Panel Type	640x480,18bit,60Hz	Optimal Default, Failsafe Default
	800x480,18bit,60Hz	
	800x600,18bit,60Hz	
	1024x600,18bit,60Hz	
	1024x768,18bit,60Hz	
	1024x768,24bit,60Hz	
	1280x768,24bit,60Hz	
	1280x1024,48bit,60Hz	
	1366x768,24bit,60Hz	

	1440x900,48bit,60Hz	
	1600x1200,48bit,60Hz	
	1920x1080,48bit,60Hz	
	1920x1200,48bit,60Hz	
Select LCD panel used by Internal Graphics Device by selecting the appropriate setup item.		
Panel Mode	Single Channel	Optimal Default, Failsafe Default
	Dual Channel	
Panel mode selection for Single channel or Dual channel		
Color Depth	18-bit	Optimal Default, Failsafe Default
	24-bit	
	36-bit	
	48-bit	
Select panel type		
Backlight Mode	BIOS & Application	Optimal Default, Failsafe Default
	Windows Slider	
Select backlight control signal type		

3.6 Setup Submenu: Security



Change User/Administrator Password

You can set an Administrator Password or User Password. An Administrator Password must be set before you can set a User Password. The password will be required during boot up, or when the user enters the Setup utility. A User Password does not provide access to many of the features in the Setup utility.

Select the password you wish to set, and press Enter. In the dialog box, enter your password (must be between 3 and 20 letters or numbers). Press Enter and retype your password to confirm. Press Enter again to set the password.

Removing the Password

Select the password you want to remove and enter the current password. At the next dialog box press Enter to disable password protection.

3.6.1 Secure Boot

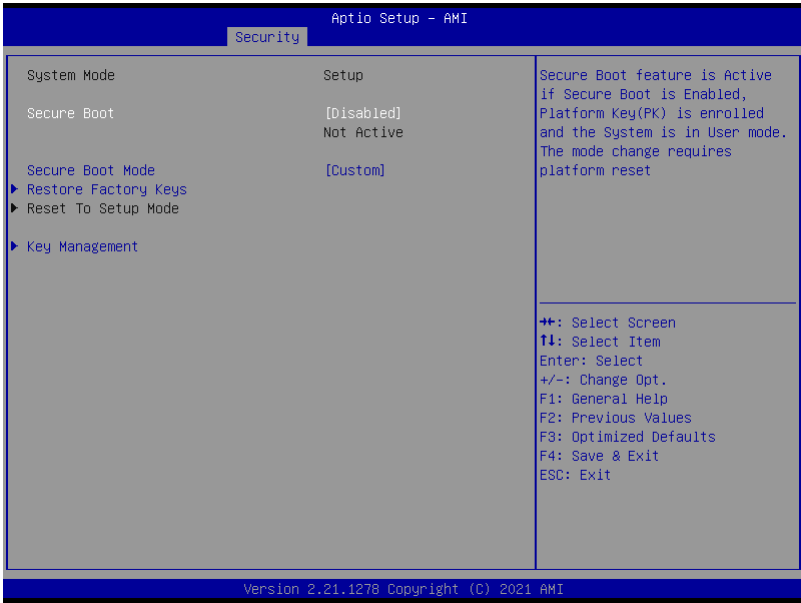

Secure Boot	Disabled	Optimal Default, Failsafe Default
	Enabled	
Secure Boot feature is Active if Secure Boot is Enabled, Platform Key(PK) is enrolled and the System is in User mode. The mode change requires platform reset		
Secure Boot Mode	Custom	Optimal Default, Failsafe Default
	Standard	
Secure Boot mode options: Standard or Custom. In Custom mode, Secure Boot Policy variables can be configured by a physically present user without full authentication		
Restore Factory Keys		
Force System to User Mode. Install factory default Secure Boot key databases		
Reset To Setup Mode		
Delete all Secure Boot key databases from NVRAM		

3.6.1.1 Key Management

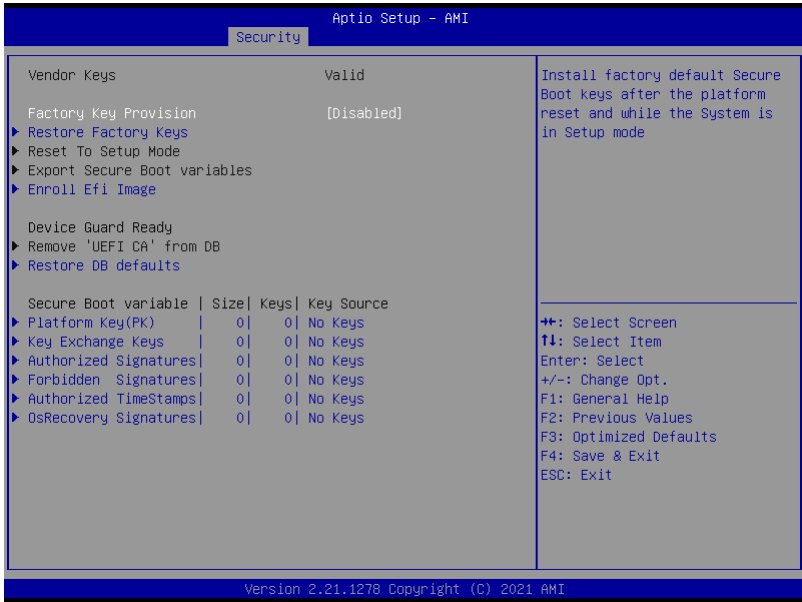

Options summary:

Factory Key	Disabled	Optimal Default, Failsafe Default
Provision	Enabled	
Secure Boot feature is Active if Secure Boot is Enabled, Platform Key(PK) is enrolled and the System is in User mode. The mode change requires platform reset		
Restore Factory Keys		
Force System to User Mode. Install factory default Secure Boot key databases		
Reset To Setup Mode		
Delete all Secure Boot key databases from NVRAM		
Export Secure Boot variables		
Copy NVRAM content of Secure Boot variables to files in a root folder on a file system device		
Enroll Efi Image		

Allow the image to run in Secure Boot mode. Enroll SHA256 Hash certificate of a PE image into Authorized Signature Database (db)	
Remove 'UEFI CA' from DB	
Device Guard ready system must not list 'Microsoft UEFI CA' Certificate in Authorized Signature database (db)	
Restore DB defaults	
Restore DB variable to factory defaults	
Platform Key(PK)	Details
	Export
	Update
	Delete
Key Exchange Keys	Details
	Export
	Update
	Append
	Delete
Authorized Signatures	Details
	Export
	Update
	Append
	Delete
Forbidden Signatures	Details
	Export
	Update
	Append
	Delete
Authorized TimeStamps	Update

	Append
OsRecovery Signatures	Update
	Append
Enroll Factory Defaults or load certificates from a file: 1.Public Key Certificate: a)EFI_SIGNATURE_LIST b)EFI_CERT_X509 (DER) c)EFI_CERT_RSA2048 (bin) d)EFI_CERT_SHAXXX 2.Authenticated UEFI Variable 3.EFI PE/COFF Image(SHA256) Key Source: Factory,External,Mixed	

3.7 Setup Submenu: Boot

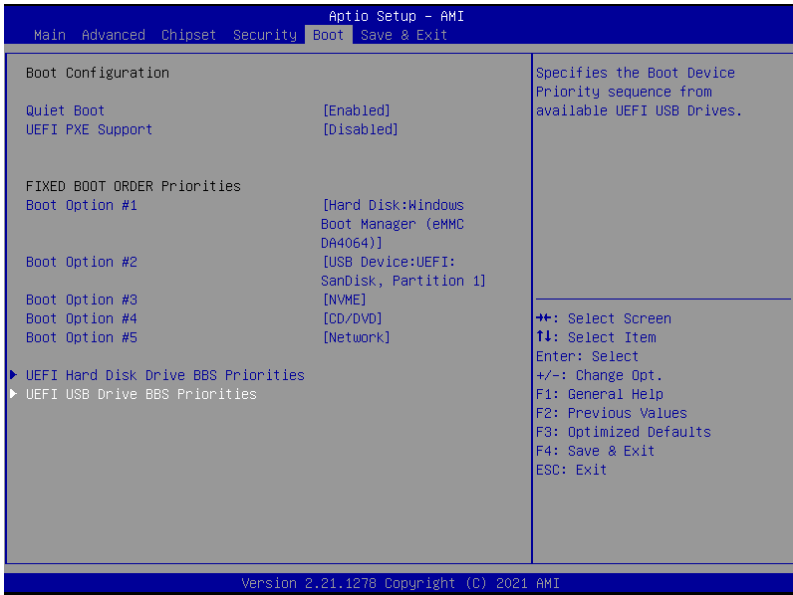

Options summary:

Quiet Boot	Disabled	Optimal Default, Failsafe Default
	Enabled	
Enable or Disable Quiet Boot option.		
UEFI PXE Support	Disabled	Optimal Default, Failsafe Default
	Enabled	
Enable/Disable UEFI Network Stack.		
FIXED BOOT ORDER Priorities		Sets the system boot order

3.7.1 BBS Priorities



3.8 Setup Submenu: Save & Exit

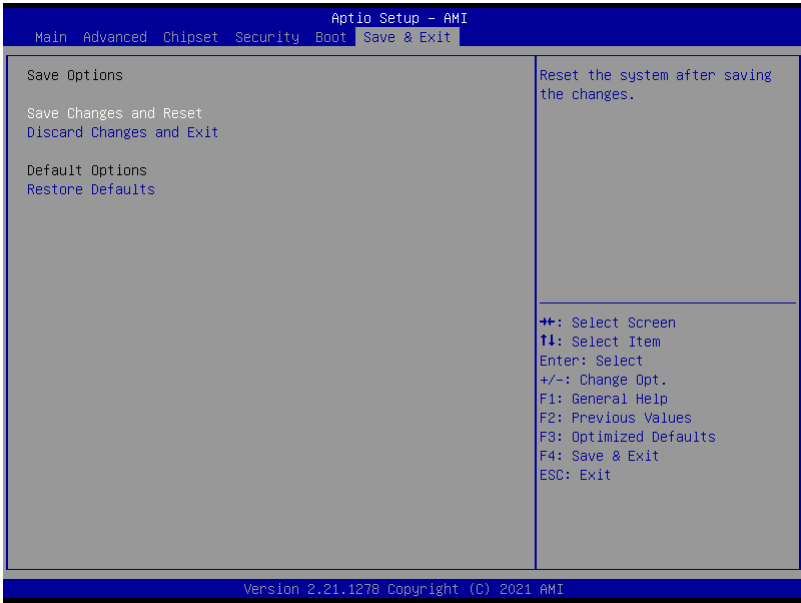

Options summary:

Save Changes and Reset	Reset the system after saving the changes.
Discard Changes and Exit	Exit system setup without saving any changes.
Restore Defaults	Restore/Load Default values for all the setup options.

Chapter 4

Driver Installation

4.1 Driver Download/Installation

Drivers for the GENE-EHL5 can be downloaded from the product page on the AAEON website by following this link:

<https://www.aaeon.com/en/p/subcompact-boards-gene-ehl5>

Download the driver(s) you need and follow the steps below to install them.

Step 1 – Install Chipset Drivers

1. Open the **Intel Chipset** folder
2. Run the **SetupChipset.exe** in the folder
3. Follow the instructions
4. Drivers will be installed automatically

Step 2 – Install Graphics Drivers

1. Open the **Intel Graphics** folder
2. Run the **igxpim.exe** file in the folder
3. Follow the instructions
4. Drivers will be installed automatically

Step 3 – Install LAN Driver

1. Open the **Intel LAN** folder
2. Run the **PROWinx64.exe** file in the folder
3. Follow the instructions
4. Drivers will be installed automatically

Step 4 – Install Audio Driver

1. Open the **Audio** folder
2. Run the **Setup.exe** file in the folder
3. Follow the instructions
4. Drivers will be installed automatically

Step 5 – Install Serial IO Drivers

1. Open the **Serial IO** folder
2. Follow the instructions
3. Drivers will be installed automatically

Step 6 – Install ME Drivers

1. Open the **ME** folder
2. Run the **SetupME.exe** file in the folder
3. Follow the instructions
4. Drivers will be installed automatically

Step 7 – Install Touch Drivers

1. Open the **Touch** folder
2. Run the **Setup.exe** file in the folder
3. Follow the instructions
4. Drivers will be installed automatically

Step 8 – Peripheral Drivers









































1. Open the **Ecilite, PSE_HECI, or PSEIO** folder.
2. Peripheral Drivers .inf files will need to be installed manually.











Appendix A

I/O Information

A.1 I/O Address Map

3.5" Subcompact Board
GENE-EHL5

▼		Input/output (IO)	
		[0000000000000000 - 000000000000CF7]	PCI Express Root Complex
		[0000000000000020 - 000000000000021]	Programmable interrupt controller
		[0000000000000024 - 000000000000025]	Programmable interrupt controller
		[0000000000000028 - 000000000000029]	Programmable interrupt controller
		[000000000000002C - 00000000000002D]	Programmable interrupt controller
		[000000000000002E - 00000000000002F]	Motherboard resources
		[0000000000000030 - 000000000000031]	Programmable interrupt controller
		[0000000000000034 - 000000000000035]	Programmable interrupt controller
		[0000000000000038 - 000000000000039]	Programmable interrupt controller
		[000000000000003C - 00000000000003D]	Programmable interrupt controller
		[0000000000000040 - 000000000000043]	System timer
		[000000000000004E - 00000000000004F]	Motherboard resources
		[0000000000000050 - 000000000000053]	System timer
		[0000000000000061 - 000000000000061]	Motherboard resources
		[0000000000000063 - 000000000000063]	Motherboard resources
		[0000000000000065 - 000000000000065]	Motherboard resources
		[0000000000000067 - 000000000000067]	Motherboard resources
		[0000000000000070 - 000000000000070]	Motherboard resources
		[0000000000000080 - 000000000000080]	Motherboard resources
		[0000000000000092 - 000000000000092]	Motherboard resources
		[00000000000000A0 - 0000000000000A1]	Programmable interrupt controller
		[00000000000000A4 - 0000000000000A5]	Programmable interrupt controller
		[00000000000000A8 - 0000000000000A9]	Programmable interrupt controller
		[00000000000000AC - 0000000000000AD]	Programmable interrupt controller
		[00000000000000B0 - 0000000000000B1]	Programmable interrupt controller
		[00000000000000B2 - 0000000000000B3]	Motherboard resources
		[00000000000000B4 - 0000000000000B5]	Programmable interrupt controller
		[00000000000000B8 - 0000000000000B9]	Programmable interrupt controller
		[00000000000000BC - 0000000000000BD]	Programmable interrupt controller
		[00000000000002E8 - 00000000000002EF]	Communications Port (COM4)
		[00000000000002F8 - 00000000000002FF]	Communications Port (COM2)
		[00000000000003E8 - 00000000000003EF]	Communications Port (COM3)
		[00000000000003F8 - 00000000000003FF]	Communications Port (COM1)
		[00000000000004D0 - 00000000000004D1]	Programmable interrupt controller
		[0000000000000680 - 000000000000069F]	Motherboard resources
		[0000000000000A00 - 0000000000000A0F]	Motherboard resources
		[0000000000000A10 - 0000000000000A1F]	Motherboard resources
		[0000000000000A20 - 0000000000000A2F]	Motherboard resources
		[0000000000000D00 - 000000000000FFFF]	PCI Express Root Complex
		[000000000000164E - 000000000000164F]	Motherboard resources

	[000000000000164E - 000000000000164F]	Motherboard resources
	[0000000000001800 - 00000000000018FE]	Motherboard resources
	[0000000000001854 - 0000000000001857]	Motherboard resources
	[0000000000002000 - 00000000000020FE]	Motherboard resources
	[0000000000003000 - 0000000000003FFF]	Intel(R) PCI Express Root Port #6 - 4B3E
	[0000000000004000 - 000000000000403F]	Intel(R) UHD Graphics
	[0000000000004060 - 000000000000407F]	Standard SATA AHCI Controller
	[0000000000004080 - 0000000000004083]	Standard SATA AHCI Controller
	[0000000000004090 - 0000000000004097]	Standard SATA AHCI Controller
	[000000000000EFA0 - 000000000000EFBF]	Intel(R) SMBus Controller - 4B23











































A.2 Memory Address Map











































Address Range	Device Name
[0000000000A0000 - 0000000000BFFFF]	PCI Express Root Complex
[000000007FC0000 - 000000007FC1FFFF]	Intel(R) I210 Gigabit Network Connection
[000000007FC0000 - 000000007FCFFFF]	Intel(R) PCI Express Root Port #6 - 4B3E
[000000007FC0000 - 00000000BFFFFFFF]	PCI Express Root Complex
[000000007FC2000 - 000000007FC2FFFF]	Intel(R) I210 Gigabit Network Connection
[000000007FD0000 - 000000007FD01FFF]	Standard SATA AHCI Controller
[000000007FD0200 - 000000007FD027FF]	Standard SATA AHCI Controller
[000000007FD0300 - 000000007FD030FF]	Standard SATA AHCI Controller
[00000000C000000 - 00000000CFFFFFFF]	Motherboard resources
[00000000FD00000 - 00000000FD68FFFF]	Motherboard resources
[00000000FD69000 - 00000000FD69FFFF]	Intel(R) Serial IO GPIO Host Controller - INTC1020
[00000000FD6A000 - 00000000FD6AFFFF]	Intel(R) Serial IO GPIO Host Controller - INTC1020
[00000000FD6B000 - 00000000FD6BFFFF]	Intel(R) Serial IO GPIO Host Controller - INTC1020
[00000000FD6B000 - 00000000FD6CFFFF]	Motherboard resources
[00000000FD6C000 - 00000000FD6CFFFF]	Intel(R) Serial IO GPIO Host Controller - INTC1020
[00000000FD6D000 - 00000000FD6DFFFF]	Intel(R) Serial IO GPIO Host Controller - INTC1020
[00000000FD6E000 - 00000000FD6EFFFF]	Intel(R) Serial IO GPIO Host Controller - INTC1020
[00000000FD6F000 - 00000000FDFFFFFF]	Motherboard resources
[00000000FE00000 - 00000000FE01FFFF]	Motherboard resources
[00000000FE01000 - 00000000FE010FFF]	Intel(R) SPI (flash) Controller - 4B24
[00000000FE05000 - 00000000FE053FFF]	Unknown device
[00000000FE06000 - 00000000FE063FFF]	Unknown device
[00000000FE20000 - 00000000FE7FFFF]	Motherboard resources
[00000000FEC8000 - 00000000FECFFFF]	Motherboard resources
[00000000FED0000 - 00000000FED003FF]	High precision event timer
[00000000FED2000 - 00000000FED7FFFF]	Motherboard resources
[00000000FED4000 - 00000000FED44FFF]	Trusted Platform Module 2.0
[00000000FED4500 - 00000000FED8FFFF]	Motherboard resources
[00000000FED9000 - 00000000FED93FFF]	Motherboard resources
[00000000FEDA000 - 00000000FEDA0FFF]	Motherboard resources
[00000000FEDA100 - 00000000FEDA1FFF]	Motherboard resources
[00000000FEE0000 - 00000000FEEFFFF]	Motherboard resources
[00000000FF00000 - 00000000FFFFFFF]	Motherboard resources
[000000400000000 - 000000400FFFFFFF]	Intel(R) UHD Graphics
[000000600000000 - 000000600FFFFFFF]	Intel(R) UHD Graphics
[000000600132000 - 000000600132FFFF]	Intel(R) USB 3.10 eXtensible Host Controller - 1.20 (Microsoft)
[000000600133E00 - 000000600133E0FF]	Intel(R) SMBus Controller - 4B23
[000000600133F00 - 000000600133FFFF]	SDA Standard Compliant SD Host Controller
[0000007FFF00000 - 0000007FFF0FFFFF]	Intel(R) Integrated Sensor Solution
[0000007FFFEF400 - 0000007FFFEF5FFF]	Intel(R) Serial IO I2C Host Controller - 4BB9
[0000007FFFEF600 - 0000007FFFEF7FFF]	Intel(R) Serial IO I2C Host Controller - 4BBD
[0000007FFFEF600 - 0000007FFFEF7FFF]	Intel(R) Serial IO I2C Host Controller - 4BBD
[0000007FFFEF800 - 0000007FFFEF9FFF]	Intel(R) Serial IO I2C Host Controller - 4BC0
[0000007FFFEFB00 - 0000007FFFEFBFFF]	Intel(R) Management Engine Interface #1
[0000007FFFEFC00 - 0000007FFFEFFFFF]	High Definition Audio Controller
[0000007FFFEF0000 - 0000007FFFEFFFFF]	High Definition Audio Controller

Large Memory









[0000004000000000 - 0000007FFFFFFF] PCI Express Root Complex

A.3 IRQ Mapping Chart

▼		Interrupt request (IRQ)	
		(ISA) 0x00000000 (00)	System timer
		(ISA) 0x00000003 (03)	Communications Port (COM2)
		(ISA) 0x00000004 (04)	Communications Port (COM1)
		(ISA) 0x0000000B (11)	Communications Port (COM3)
		(ISA) 0x0000000B (11)	Communications Port (COM4)
		(ISA) 0x0000000E (14)	Intel(R) Serial IO GPIO Host Controller - INTC1020
		(ISA) 0x00000023 (35)	Unknown device
		(ISA) 0x00000024 (36)	Unknown device
		(ISA) 0x00000036 (54)	Microsoft ACPI-Compliant System
		(ISA) 0x00000037 (55)	Microsoft ACPI-Compliant System
		(ISA) 0x00000038 (56)	Microsoft ACPI-Compliant System
		(ISA) 0x00000039 (57)	Microsoft ACPI-Compliant System
		(ISA) 0x0000003A (58)	Microsoft ACPI-Compliant System
		(ISA) 0x0000003B (59)	Microsoft ACPI-Compliant System
		(ISA) 0x0000003C (60)	Microsoft ACPI-Compliant System
		(ISA) 0x0000003D (61)	Microsoft ACPI-Compliant System
		(ISA) 0x0000003E (62)	Microsoft ACPI-Compliant System
		(ISA) 0x0000003F (63)	Microsoft ACPI-Compliant System
		(ISA) 0x00000040 (64)	Microsoft ACPI-Compliant System
		(ISA) 0x00000041 (65)	Microsoft ACPI-Compliant System
		(ISA) 0x00000042 (66)	Microsoft ACPI-Compliant System
		(ISA) 0x00000043 (67)	Microsoft ACPI-Compliant System
		(ISA) 0x00000044 (68)	Microsoft ACPI-Compliant System
		(ISA) 0x00000045 (69)	Microsoft ACPI-Compliant System
		(ISA) 0x00000046 (70)	Microsoft ACPI-Compliant System
		(ISA) 0x00000047 (71)	Microsoft ACPI-Compliant System
		(ISA) 0x00000048 (72)	Microsoft ACPI-Compliant System
		(ISA) 0x00000049 (73)	Microsoft ACPI-Compliant System
		(ISA) 0x0000004A (74)	Microsoft ACPI-Compliant System
		(ISA) 0x0000004B (75)	Microsoft ACPI-Compliant System
		(ISA) 0x0000004C (76)	Microsoft ACPI-Compliant System
		(ISA) 0x0000004D (77)	Microsoft ACPI-Compliant System
		(ISA) 0x0000004E (78)	Microsoft ACPI-Compliant System
		(ISA) 0x0000004F (79)	Microsoft ACPI-Compliant System
		(ISA) 0x00000050 (80)	Microsoft ACPI-Compliant System
		(ISA) 0x00000051 (81)	Microsoft ACPI-Compliant System
		(ISA) 0x00000052 (82)	Microsoft ACPI-Compliant System
		(ISA) 0x00000053 (83)	Microsoft ACPI-Compliant System
		(ISA) 0x00000054 (84)	Microsoft ACPI-Compliant System
		(ISA) 0x00000055 (85)	Microsoft ACPI-Compliant System
		(ISA) 0x00000056 (86)	Microsoft ACPI-Compliant System

	(ISA) 0x000001E8 (488)	Microsoft ACPI-Compliant System
	(ISA) 0x000001E9 (489)	Microsoft ACPI-Compliant System
	(ISA) 0x000001EA (490)	Microsoft ACPI-Compliant System
	(ISA) 0x000001EB (491)	Microsoft ACPI-Compliant System
	(ISA) 0x000001EC (492)	Microsoft ACPI-Compliant System
	(ISA) 0x000001ED (493)	Microsoft ACPI-Compliant System
	(ISA) 0x000001EE (494)	Microsoft ACPI-Compliant System
	(ISA) 0x000001EF (495)	Microsoft ACPI-Compliant System
	(ISA) 0x000001F0 (496)	Microsoft ACPI-Compliant System
	(ISA) 0x000001F1 (497)	Microsoft ACPI-Compliant System
	(ISA) 0x000001F2 (498)	Microsoft ACPI-Compliant System
	(ISA) 0x000001F3 (499)	Microsoft ACPI-Compliant System
	(ISA) 0x000001F4 (500)	Microsoft ACPI-Compliant System
	(ISA) 0x000001F5 (501)	Microsoft ACPI-Compliant System
	(ISA) 0x000001F6 (502)	Microsoft ACPI-Compliant System
	(ISA) 0x000001F7 (503)	Microsoft ACPI-Compliant System
	(ISA) 0x000001F8 (504)	Microsoft ACPI-Compliant System
	(ISA) 0x000001F9 (505)	Microsoft ACPI-Compliant System
	(ISA) 0x000001FA (506)	Microsoft ACPI-Compliant System
	(ISA) 0x000001FB (507)	Microsoft ACPI-Compliant System
	(ISA) 0x000001FC (508)	Microsoft ACPI-Compliant System
	(ISA) 0x000001FD (509)	Microsoft ACPI-Compliant System
	(ISA) 0x000001FE (510)	Microsoft ACPI-Compliant System
	(ISA) 0x000001FF (511)	Microsoft ACPI-Compliant System
	(PCI) 0x00000010 (16)	High Definition Audio Controller
	(PCI) 0x00000010 (16)	SDA Standard Compliant SD Host Controller
	(PCI) 0xFFFFFFFEE (-18)	Intel(R) Serial IO I2C Host Controller - 4BB9
	(PCI) 0xFFFFFFFEF (-17)	Intel(R) Serial IO I2C Host Controller - 4BBD
	(PCI) 0xFFFFFFF0 (-16)	Intel(R) Serial IO I2C Host Controller - 4BC0
	(PCI) 0xFFFFFFF1 (-15)	Intel(R) Integrated Sensor Solution
	(PCI) 0xFFFFFFF2 (-14)	Intel(R) Management Engine Interface #1
	(PCI) 0xFFFFFFF3 (-13)	Intel(R) I210 Gigabit Network Connection
	(PCI) 0xFFFFFFF4 (-12)	Intel(R) I210 Gigabit Network Connection
	(PCI) 0xFFFFFFF5 (-11)	Intel(R) I210 Gigabit Network Connection
	(PCI) 0xFFFFFFF6 (-10)	Intel(R) I210 Gigabit Network Connection
	(PCI) 0xFFFFFFF7 (-9)	Intel(R) I210 Gigabit Network Connection
	(PCI) 0xFFFFFFF8 (-8)	Intel(R) I210 Gigabit Network Connection
	(PCI) 0xFFFFFFF9 (-7)	Intel(R) USB 3.10 eXtensible Host Controller - 1.20 (Microsoft)
	(PCI) 0xFFFFFFFA (-6)	Intel(R) UHD Graphics
	(PCI) 0xFFFFFFF8 (-5)	Standard SATA AHCI Controller
	(PCI) 0xFFFFFFF8 (-4)	Intel(R) PCI Express Root Port #1 - 4B39
	(PCI) 0xFFFFFFF8 (-3)	Intel(R) PCI Express Root Port #0 - 4B38

A.4 DMA Channel Assignments

- ▼  Direct memory access (DMA)
 -  0 Intel(R) Serial IO I2C Host Controller - 4BB9
 -  0 Intel(R) Serial IO I2C Host Controller - 4BBD
 -  1 Intel(R) Serial IO I2C Host Controller - 4BB9
 -  1 Intel(R) Serial IO I2C Host Controller - 4BBD
 -  6 Intel(R) Serial IO I2C Host Controller - 4BC0
 -  7 Intel(R) Serial IO I2C Host Controller - 4BC0
 -  ...

Appendix B

Mating Connectors and Cables

B.1 Mating Connectors and Cables

Connector Label	Function	Mating Connector		Available Cable	Cable P/N
		Vendor	Model no		
CN1	RTC Battery	Molex	51021-0200	Battery Cable	175011301C
CN2	Touch Screen Connector	JST	SHR-9V-S-B	N/A	N/A
CN3	Audio IO Port	JCTC	HSG:11002H0 0-2*6P TER:11002TO P-2E	Audio Cable	170X000156
CN4	Amplifier R-channel output	Molex	51021-0200	N/A	N/A
CN5	Amplifier L-channel output	Molex	51021-0200	N/A	N/A
CN9	LVDS/eDP Port Inverter / Backlight Connector	SHR	HSG: WL1010H-6P TER: KB901-10T	LVDS Inverter Cable	170X000152
CN10	LVDS Port	SHDR	HSG: WL1010H-2*2 0P TER: KB901-10T	LVDS Cable	170X000280
	EDP Port	JCTC	HSG:11002H0 0-2*20P TER:11002-T	EDP Cable	170X000409
CN16	SATA port	Molex	887505318	SATA Cable	1709070500

Connector Label	Function	Mating Connector		Available Cable	Cable P/N
		Vendor	Model no		
CN17	+5V Output for SATA HDD	JST	PHR-2	SATA Power Cable	1702150155
CN18 CN19	Digital IO Port	ACES	50247-010H0 H0-001	N/A	N/A
CN21 CN22	USB 2.0 Port	ACES	50247-010H0 H0-001	USB2.0 Cable	170010010D
CN27	COM Port 1~4	JCTC	HSG:11002H0 0-2*20P TER:11002TO P-2E	COM Cable	170X000317
CN32	eSPI Debug Port	JST	SHR-10V-S-B	N/A	N/A
CN33	CPU FAN	Molex	47054-1000	N/A	N/A
CN34	External Power Input	Molex	19211-0003	Power Cable	170204010R
CN36	Front Panel	Molex	51110-1050	N/A	N/A
CN38	CAN BUS	Molex	51021-0500	N/A	N/A
CN43 CN44	LAN1&2 SDP Connector	JST	SHR-04V-S-B	N/A	N/A

Note: eDP Test Panel: INNOLUX N116HSE-EBC & LVDS Test Panel: AUO G121XN01 V0