

GENE-ADN6

3.5" Subcompact Board

User's Manual 2nd Ed

Copyright Notice

This document is copyrighted, 2024. All rights are reserved. The original manufacturer reserves the right to make improvements to the products described in this manual at any time without notice.

No part of this manual may be reproduced, copied, translated, or transmitted in any form or by any means without the prior written permission of the original manufacturer. Information provided in this manual is intended to be accurate and reliable. However, the original manufacturer assumes no responsibility for its use, or for any infringements upon the rights of third parties that may result from its use.

The material in this document is for product information only and is subject to change without notice. While reasonable efforts have been made in the preparation of this document to assure its accuracy, AAЕON assumes no liabilities resulting from errors or omissions in this document, or from the use of the information contained herein.

AAЕON reserves the right to make changes in the product design without notice to its users.

Acknowledgements

All other products' name or trademarks are properties of their respective owners.

- Microsoft Windows is a registered trademark of Microsoft Corp.
- Intel Atom® is a registered trademark of Intel Corporation
- Intel® Core™ is a trademark of Intel Corporation
- Realtek is a trademark of Realtek Semiconductor Corporation.
- Ubuntu is a trademark of Canonical.
- Linux® is the registered trademark of Linus Torvalds in the U.S. and other countries

All other product names or trademarks are properties of their respective owners.

Packing List

Before setting up your product, please make sure the following items have been shipped:

Item	Quantity
GENE-ADN6	1

If any of these items are missing or damaged, please contact your distributor or sales representative immediately.

About this Document

This User's Manual contains all the essential information, such as detailed descriptions and explanations on the product's hardware and software features (if any), its specifications, dimensions, jumper/connector settings/definitions, and driver installation instructions (if any), to facilitate users in setting up their product.

Users may refer to the product page at AAEON.com for the latest version of this document.

Safety Precautions

Please read the following safety instructions carefully. It is advised that you keep this manual for future references

1. All cautions and warnings on the device should be noted.
2. Make sure the power source matches the power rating of the device.
3. Position the power cord so that people cannot step on it. Do not place anything over the power cord.
4. Always completely disconnect the power before working on the system's hardware.
5. No connections should be made when the system is powered as a sudden rush of power may damage sensitive electronic components.
6. If the device is not to be used for a long time, disconnect it from the power supply to avoid damage by transient over-voltage.
7. Always disconnect this device from any AC supply before cleaning.
8. While cleaning, use a damp cloth instead of liquid or spray detergents.
9. Make sure the device is installed near a power outlet and is easily accessible.
10. Keep this device away from humidity.
11. Place the device on a solid surface during installation to prevent falls
12. Do not cover the openings on the device to ensure optimal heat dissipation.
13. Watch out for high temperatures when the system is running.
14. Do not touch the heat sink or heat spreader when the system is running
15. Never pour any liquid into the openings. This could cause fire or electric shock.
16. As most electronic components are sensitive to static electrical charge, be sure to ground yourself to prevent static charge when installing the internal components. Use a grounding wrist strap and contain all electronic components in any static-shielded containers.

17. If any of the following situations arises, please contact our service personnel:
 - i. Damaged power cord or plug
 - ii. Liquid intrusion to the device
 - iii. Exposure to moisture
 - iv. Device is not working as expected or in a manner as described in this manual
 - v. The device is dropped or damaged
 - vi. Any obvious signs of damage displayed on the device
18. **DO NOT LEAVE THIS DEVICE IN AN UNCONTROLLED ENVIRONMENT WITH TEMPERATURES BEYOND THE DEVICE'S PERMITTED STORAGE TEMPERATURES (SEE CHAPTER 1) TO PREVENT DAMAGE.**

Warning!



This device complies with Part 15 FCC Rules. Operation is subject to the following two conditions: (1) this device may not cause harmful interference, and (2) this device must accept any interference received including interference that may cause undesired operation.

Caution:

There is a danger of explosion if the battery is incorrectly replaced. Replace only with the same or equivalent type recommended by the manufacturer. Dispose of used batteries according to the manufacturer's instructions and your local government's recycling or disposal directives.

Attention:

Il y a un risque d'explosion si la batterie est remplacée de façon incorrecte. Ne la remplacer qu'avec le même modèle ou équivalent recommandé par le constructeur. Recycler les batteries usées en accord avec les instructions du fabricant et les directives gouvernementales de recyclage.

China RoHS Requirements (CN)

产品中有毒有害物质或元素名称及含量

AAEON Main Board/ Daughter Board/ Backplane

部件名称	有毒有害物质或元素					
	铅 (Pb)	汞 (Hg)	镉 (Cd)	六价铬 (Cr(VI))	多溴联苯 (PBB)	多溴二苯醚 (PBDE)
印刷电路板 及其电子组件	X	X	○	○	○	○
外部信号 连接器及线材	X	X	○	○	○	○
<p>O: 表示该有毒有害物质在该部件所有均质材料中的含量均在 SJ/T 11363-2006 标准规定的限量要求以下。</p> <p>X: 表示该有毒有害物质至少在该部件的某一均质材料中的含量超出 SJ/T 11363-2006 标准规定的限量要求。</p> <p>备注: 此产品所标示之环保使用期限, 系指在一般正常使用状况下。</p>						

China RoHS Requirement (EN)

Poisonous or Hazardous Substances or Elements in Products

AAEON Main Board/ Daughter Board/ Backplane

Component	Poisonous or Hazardous Substances or Elements					
	Lead (Pb)	Mercury (Hg)	Cadmium (Cd)	Hexavalent Chromium (Cr(VI))	Polybrominated Biphenyls (PBB)	Polybrominated Diphenyl Ethers (PBDE)
PCB & Other Components	X	X	○	○	○	○
Wires & Connectors for External Connections	X	X	○	○	○	○
<p>O: The quantity of poisonous or hazardous substances or elements found in each of the component's parts is below the SJ/T 11363-2006-stipulated requirement.</p> <p>X: The quantity of poisonous or hazardous substances or elements found in at least one of the component's parts is beyond the SJ/T 11363-2006-stipulated requirement.</p> <p>Note: The Environment Friendly Use Period as labeled on this product is applicable under normal usage only</p>						

Table of Contents

Chapter 1 – Product Specifications	1
1.1 Specifications	2
1.2 Block Diagram	6
Chapter 2 – Hardware Information	7
2.1 Dimensions	8
2.2 Jumpers and Connectors.....	10
2.3 List of Jumpers	12
2.3.1 COM 2 Pin 9 Function Selection (JP1).....	13
2.3.2 COM 1 Pin 9 Function Selection (JP2).....	13
2.3.3 Auto Power Button Enable/Disable Selection (JP3)	13
2.3.4 LVDS 1 Operating Voltage Selection (JP4)	14
2.3.5 LVDS 1 Backlight Inverter Voltage Selection (JP4)	14
2.3.6 Clear CMOS Jumper (JP5).....	14
2.4 List of Connectors.....	15
2.4.1 +5V Output for SATA HDD (CN1)	17
2.4.2 Front Panel (CN2).....	17
2.4.3 Port 80 Debug Port Connector (CN3).....	18
2.4.4 SPI Flash Programming Port (CN4).....	19
2.4.5 SATA Port (CN5)	20
2.4.6 External +12V Input (Optional) (CN8).....	20
2.4.7 External Power Input (CN9).....	21
2.4.8 Audio I/O Port (CN11)	21
2.4.9 DDR5 SO-DIMM Channel (CN12).....	22
2.4.10 External +5VSB Input (CN13).....	22
2.4.11 GPIO Port (CN18)	23
2.4.12 M.2 2230 E-Key (CN21).....	24

2.4.13	LAN Port 1 LED Connector (CN22)	24
2.4.14	LAN Port 3 LED Connector (CN23).....	25
2.4.15	LAN Port 2 LED Connector (CN24)	25
2.4.16	M.2 3052 B-Key (CN25).....	26
2.4.17	Full Size Mini Card Slot/mSATA (CN27).....	26
2.4.18	LVDS 1 Connector (CN28)	28
2.4.19	Nano SIM Card Socket (CN29)	30
2.4.20	4-pin FAN Connector (CN33).....	30
2.4.21	LVDS Inverter/Backlight Connector (CN34)	31
2.4.22	RJ-45 LAN Port 3 (CN35).....	32
2.4.23	RJ-45 LAN Port 1/Port 2 (CN36).....	33
2.4.24	USB 3.2/USB 2.0 Port 1/Port 2 (CN37).....	34
2.4.25	RTC Battery Connector (CN39).....	35
2.4.26	CRT Connector (CN40).....	35
2.4.27	I2C/SMBus Connector (CN42)	36
2.4.28	HDMI Connector (CN43).....	37
2.4.29	COM Port 1 (CN44).....	38
2.4.30	COM Port 2 (CN45).....	41
2.4.31	COM Port 3 (CN46).....	44
2.4.32	COM Port 4 (CN47).....	45
2.4.33	USB 2.0 Port 3 (CN48)	46
2.4.34	USB 2.0 Port 4 (CN49)	46
2.4.35	USB 2.0 Port 5 (CN50)	47
2.4.36	USB 2.0 Port 6 (CN53)	47
2.5	Thermal Solutions.....	48
2.5.1	Heatsreader - GENE-ADN6-HSP01.....	48
2.5.2	Heatsink Option 1- GENE-ADN6-HSK01.....	50
2.5.3	Heatsink Option 2- GENE-ADN6-HSK02.....	52

Chapter 3 - AMI BIOS Setup	54
3.1 System Test and Initialization	55
3.2 AMI BIOS Setup	56
3.3 Setup Submenu: Main	57
3.4 Setup Submenu: Advanced.....	58
3.4.1 CPU Configuration.....	59
3.4.2 PCH-FW Configuration.....	60
3.4.3 Firmware Update Configuration	61
3.4.4 PTT Configuration.....	62
3.4.5 Trusted Computing.....	63
3.4.6 SATA Configuration.....	65
3.4.7 Hardware Monitor	66
3.4.7.1 Smart Fan Mode Configuration	67
3.4.8 SIO Configuration	68
3.4.8.1 Serial Port 1 Configuration	69
3.4.8.2 Serial Port 2 Configuration	70
3.4.8.3 Serial Port 3 Configuration	71
3.4.8.4 Serial Port 4 Configuration	72
3.4.9 Serial Port Console Redirection	73
3.4.10 Legacy Console Redirection Settings.....	74
3.4.11 AAEON BIOS Robot	75
3.4.12 Power Management.....	77
3.4.13 GPIO Port Configuration	78
3.4.14 AAEON Smart Boost.....	79
3.5 Setup Submenu: Chipset	80
3.5.1 System Agent (SA) Configuration.....	81
3.5.2 Memory Configuration.....	82
3.5.3 LVDS Panel Configuration	83

3.5.4	PCH-IO Configuration	85
3.6	Setup Submenu: Security.....	86
3.6.1	Secure Boot.....	87
3.6.2	Key Management.....	88
3.7	Setup Submenu: Boot	90
3.7.1	BBS Priorities	91
3.8	Setup Submenu: Save & Exit.....	92
Chapter 4 – Driver Installation		93
4.1	Driver Download/Installation	94
Appendix A - I/O Information.....		97
A.1	I/O Address Map	98
A.2	Memory Address Map	100
A.3	IRQ Mapping Chart.....	102
Appendix B – Mating Connectors and Cables.....		109
B.1	Mating Connectors and Cables.....	110

Chapter 1

Product Specifications

1.1 Specifications

System

Form Factor	3.5" SubCompact Board
CPU	Intel Atom® x7000E Series, Intel® Processor N-series, Intel® Core™ i3-N305 Processors: Intel® Core™ i3-N305 (8C/8T, up to 3.8 GHz, 15W) Intel Atom® x7425E (4C/4T, up to 3.4 GHz, 12W) Intel® Processor N97 (4C/4T, up to 3.6 GHz, 12W) Intel® Processor N50 (2C/2T, up to 3.4 GHz, 6W)
Chipset	Integrated with Intel® SoC
Memory Type	DDR5 4800, Single Channel SODIMM x 1, Max. 16GB, Non-ECC
BIOS	UEFI
Wake on Lan	Yes
Watchdog Timer	255 Levels
Security	TPM 2.0 (Optional)
RTC Battery	Lithium Battery 3V/240mAH
Dimension	5.75" x 4" (146mm x 101.6mm)
Weight	0.94 lb. (0.43Kg)
OS Support	Windows® 10 (64-bit) Ubuntu 22.04/Kernel 5.15.0-25-generic

Power

Power Requirement	+9V ~ 36V (Optional: +12V)
Power Supply Type	AT/ATX
Connector	Phoenix 2-pin Connector

Power

Power Consumption	Intel® Core™ i3-N305, DDR5 16GB x 1, 3.4A @+12V (Typical)
	Intel® Core™ i3-N305, DDR5 16GB x 1, 5.24A @+12V (Max)

Display

Controller	Intel® UHD Graphics
LVDS/eDP	LVDS x 1, Dual Channel 18/24-bit, up to 1920 x 1080
Display Interface	HDMI 1.4 x 1, up to 3840 x 2160 @30Hz VGA x 1, up to 1920 x 1080
Multiple Display	Up to 3 Simultaneous Displays

Audio

Codec	Realtek ALC897
Audio Interface	Line-In/Line-Out/Mic
Speaker	—

External I/O

Ethernet	Intel® Ethernet Controller I226 2.5GbE, RJ-45 x 3
USB	USB 3.2 Gen 2 x 2
Serial Port	—
Video	HDMI 1.4 x 1 VGA x 1

Internal I/O

USB	USB 2.0 x 4
Serial Port	COM 1, COM 2 (RS-232/422/485, supports 5V/12V/RI) COM 3, COM 4 (RS-232)
Video	LVDS x 1 Inverter x 1 (12V/2A)
SATA	SATA 6Gb/s x 1 +5V SATA Power Connector x 1
Audio	Audio Header x 1 (Optional)
DIO/GPIO	GPIO 8-bit
SMBus/I2C	SMBus/I2C x 1 (Default: SMBus)
Touch	—
Fan	4-pin Smart Fan x 1
SIM	Nano SIM x 1
Front Panel	HDD LED, PWR LED, Power Button, Buzzer, Reset
Others	—

Expansion

Mini PCIe/mSATA	Full-size mSATA/mPCIe x 1 (Default: mSATA, select by BIOS)
M.2	M.2 2230 E-Key x 1 (PCIe 3.0 [x1] + USB 2.0) M.2 3052 B-Key x 1 (USB 3.2 Gen 2 + USB 2.0)
Others	—

Environmental

Operating Temperature	-4°F ~ 158°F (-20°C ~ 70°C) WITAS 2: -40°F ~ 185°F (-40°C ~ 85°C)
Storage Temperature	-40°F ~ 185°F (-40°C ~ 85°C)

Environmental

Operating Humidity	0% ~ 90% relative humidity, non-condensing
MTBF (Hours)	337,963
EMC	CE/FCC Class A

1.2 Block Diagram

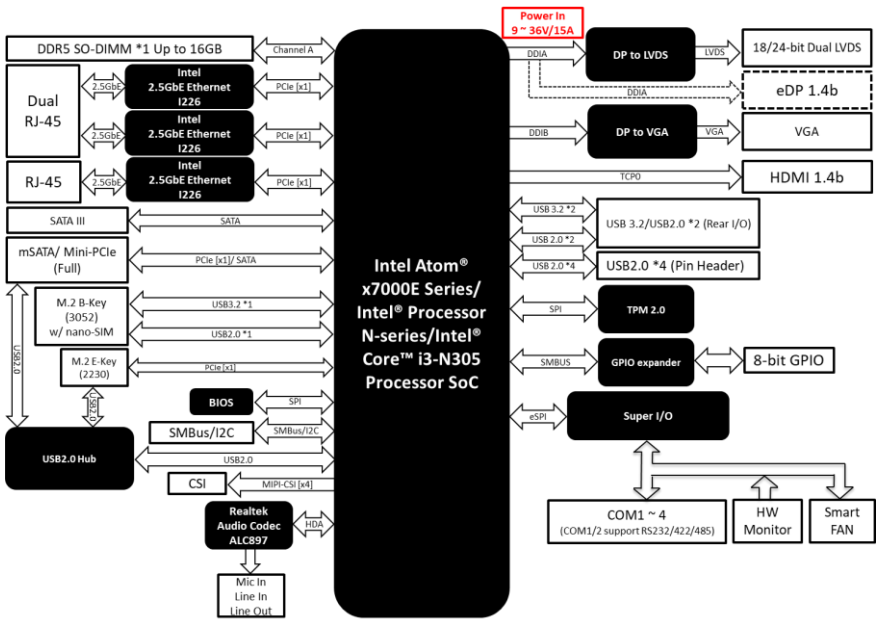

Chapter 2

Hardware Information

2.1 Dimensions

Component Side

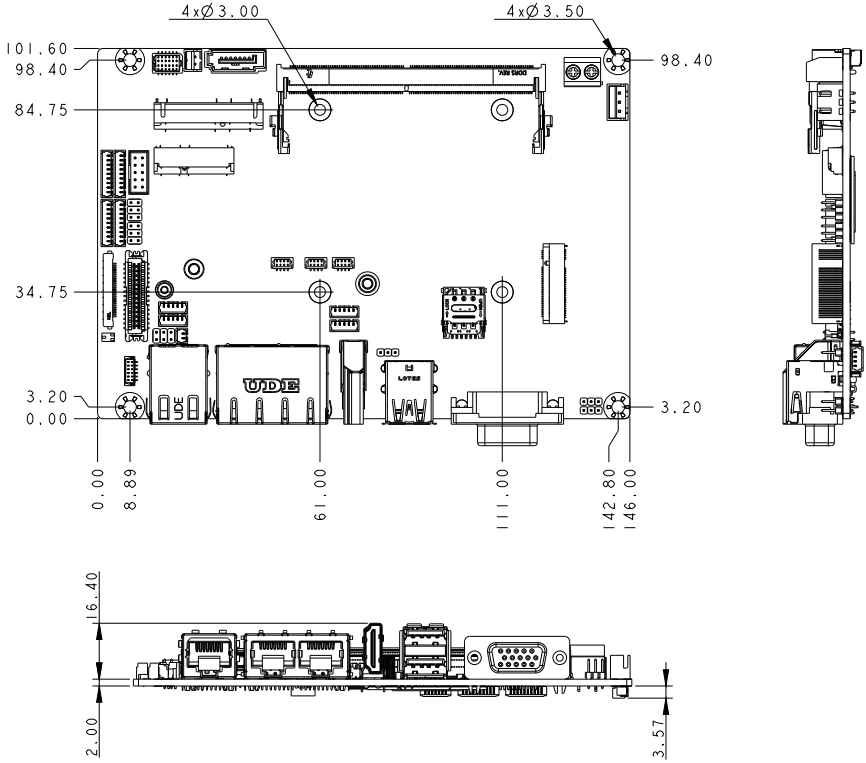

Component Side

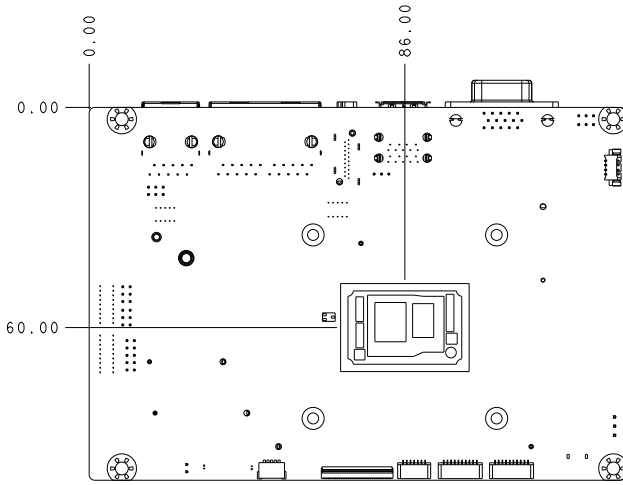

3D View

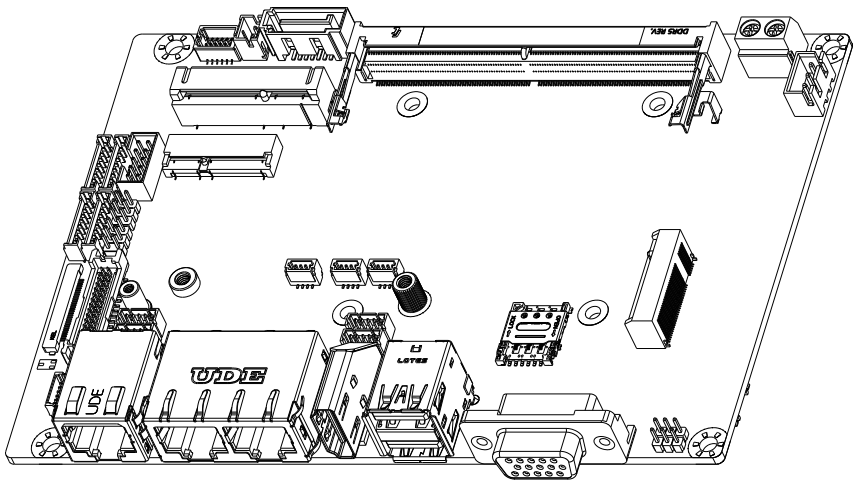

2.2 Jumpers and Connectors

Top View

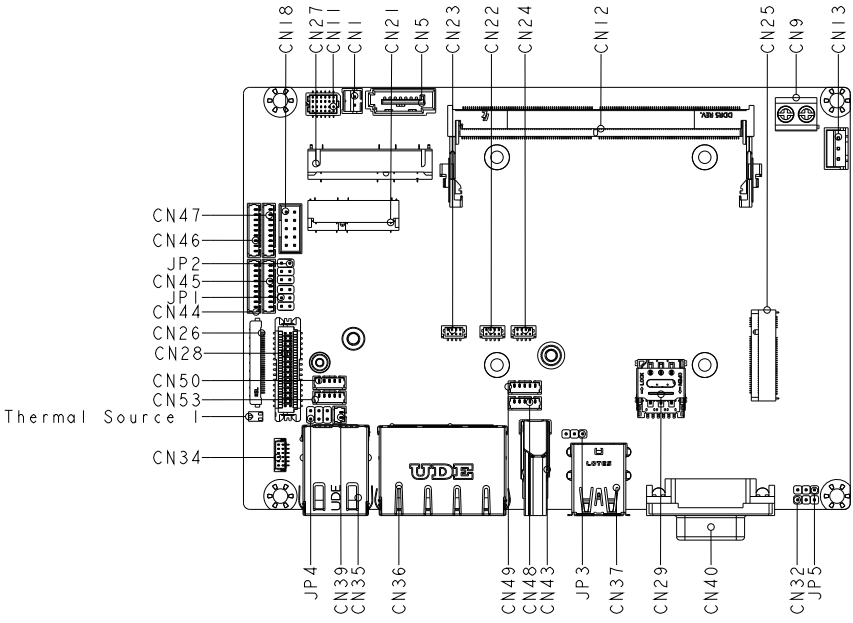

Front I/O View

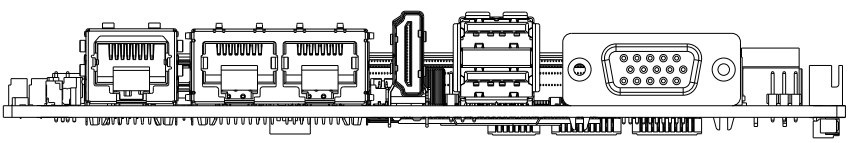

Bottom View

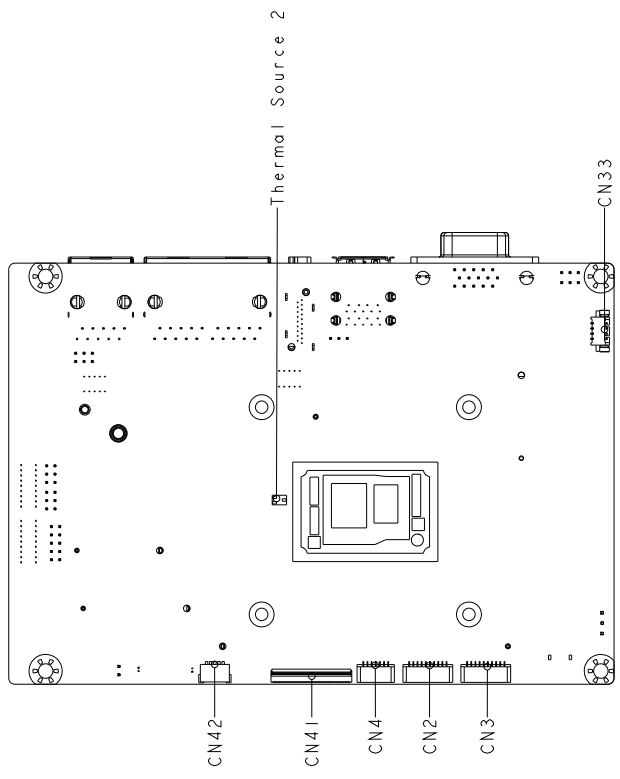

2.3 List of Jumpers

Please refer to the table below for all of the board's jumpers that you can configure for your application

Label	Function
JP1	COM 2 Pin 9 Function Selection
JP2	COM 1 Pin 9 Function Selection
JP3	Auto Power Button Enable/Disable Selection
JP4	LVDS 1 Operating Voltage Selection LVDS 1 Backlight Inverter Voltage Selection
JP5	Clear CMOS Jumper

2.3.1 COM 2 Pin 9 Function Selection (JP1)

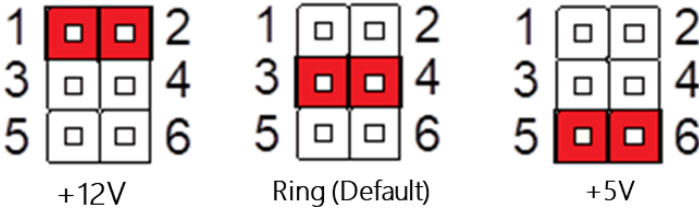

2.3.2 COM 1 Pin 9 Function Selection (JP2)

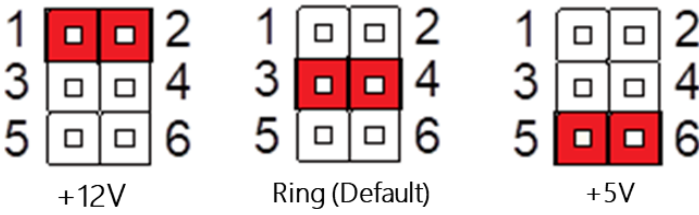

2.3.3 Auto Power Button Enable/Disable Selection (JP3)

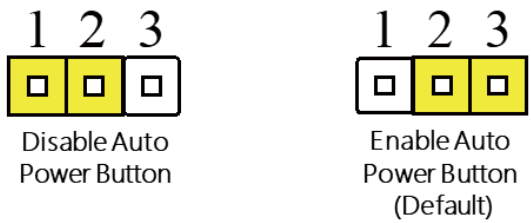

2.3.4 LVDS 1 Operating Voltage Selection (JP4)

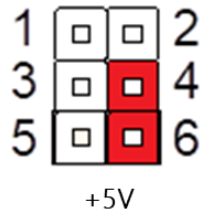
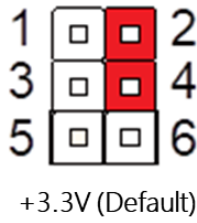

2.3.5 LVDS 1 Backlight Inverter Voltage Selection (JP4)

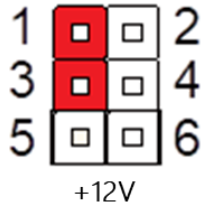
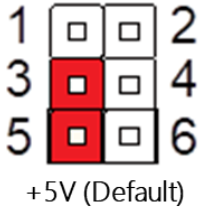

2.3.6 Clear CMOS Jumper (JP5)

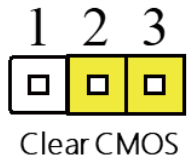
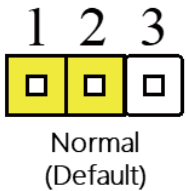

2.4 List of Connectors

Please refer to the table below for all of the board's connectors that you can configure for your application

Label	Function
CN1	+5V Output for SATA HDD
CN2	Front Panel
CN3	Port 80 Debug Port Connector
CN4	SPI Flash Programming Port
CN5	SATA Port
CN8	External +12V Input (Optional)
CN9	External Power Input
CN11	Audio I/O Port
CN12	DDR5 SODIMM
CN13	External +5VSB Input
CN18	GPIO Port
CN21	M.2 2230 E-Key
CN22	LAN Port 1 LED Connector
CN23	LAN Port 3 LED Connector
CN24	LAN Port 2 LED Connector
CN25	M.2 3052 B-Key
CN27	Full Size Mini Card Slot/mSATA
CN28	LVDS 1 Connector
CN29	Nano SIM Card Socket
CN33	4-pin FAN Connector
CN34	LVDS Inverter/Backlight Connector
CN35	RJ-45 LAN Port 3
CN36	RJ-45 LAN Port 1/Port 2
CN37	USB 3.2/USB 2.0 Port 1/Port 2
CN39	RTC Battery Connector
CN40	CRT Connector
CN42	I2C/SMBus Connector
CN43	HDMI Connector

Label	Function
CN44	COM Port 1
CN45	COM Port 2
CN46	COM Port 3
CN47	COM Port 4
CN48	USB 2.0 Port 3
CN49	USB 2.0 Port 4
CN50	USB 2.0 Port 5
CN53	USB 2.0 Port 6

2.4.1 +5V Output for SATA HDD (CN1)

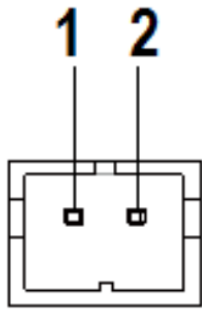

Pin	Pin Name	Signal Type	Signal Level
1	+V5S	PWR	+5V
2	GND	GND	-

Note: The driving current of +V5S supports up to 2A.

2.4.2 Front Panel (CN2)

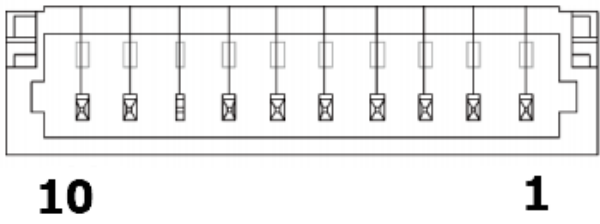

Pin	Pin Name	Signal Type	Signal Level
1	GND	GND	GND
2	EXT_PWRBTN#	IN	
3	SATA_LED-	OUT	
4	SATA_LED+	OUT	
5	BUZZER-	OUT	
6	BUZZER+	OUT	

Pin	Pin Name	Signal Type	Signal Level
7	GND	GND	GND
8	PWR_LED+	OUT	
9	GND	GND	GND
10	HWRST#	IN	

2.4.3 Port 80 Debug Port Connector (CN3)

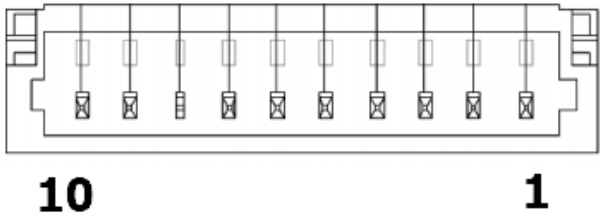

Pin	Pin Name	Signal Type	Signal Level
1	ESP_IO0	I/O	+1.8V
2	ESP_IO1	I/O	+1.8V
3	ESP_IO2	I/O	+1.8V
4	ESP_IO3	I/O	+1.8V
5	+V3P3S	PWR	+3.3V
6	ESPI_CS	IN	
7	ESPI_RST	OUT	+3.3V
8	GND	GND	GND
9	ESPI_CLK	OUT	+1.8V
10	+V3P3A	PWR	+3.3V

2.4.4 SPI Flash Programming Port (CN4)

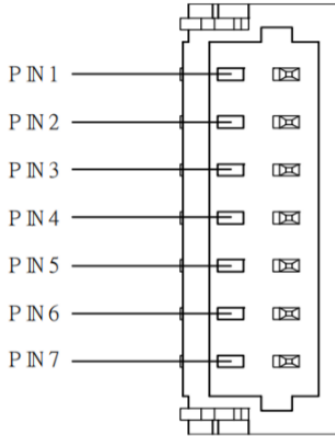

Pin	Pin Name	Signal Type	Signal Level
1	SPI_MISO	OUT	
2	GND	GND	GND
3	SPI_CLK	IN	
4	+V3P3A_SPI	PWR	+3.3V
5	SPI_MOSI	IN	
6	SPI_CS	IN	
7	NC		

2.4.5 SATA Port (CN5)

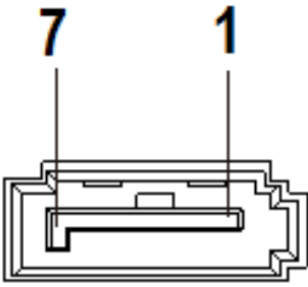

Pin	Pin Name	Signal Type	Signal Level
1	GND	GND	GND
2	SATA_TX+	DIFF	
3	SATA_TX-	DIFF	
4	GND	GND	GND
5	SATA_RX-	DIFF	
6	SATA_RX+	DIFF	
7	GND	GND	GND

2.4.6 External +12V Input (Optional) (CN8)

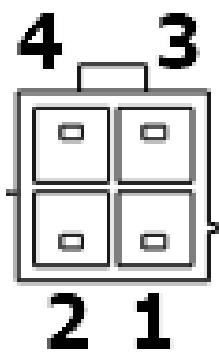

Pin	Pin Name	Signal Type	Signal Level
1	GND	GND	GND
2	GND	GND	GND

Pin	Pin Name	Signal Type	Signal Level
3	+12V	PWR	+12V
4	+12V	PWR	+12V

2.4.7 External Power Input (CN9)

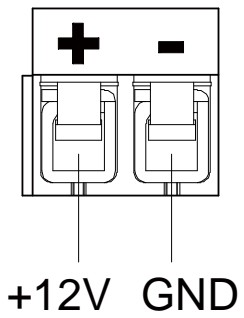

Pin	Pin Name	Signal Type	Signal Level
1	+12V	PWR	+12V
2	GND	GND	GND

2.4.8 Audio I/O Port (CN11)

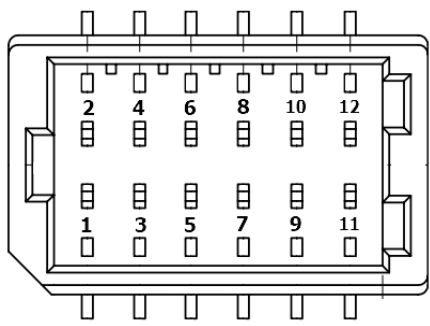

Pin	Pin Name	Signal Type	Signal Level
1	RIGHT_OUT	OUT	
2	MIC_R	IN	
3	LEFT_OUT	OUT	

Pin	Pin Name	Signal Type	Signal Level
4	MIC_L	IN	
5	JD_LOUT	IN	
6	JD_MIC	IN	
7	GND_AUDIO	GND	
8	GND_AUDIO	GND	
9	JD_LIN	IN	
10	LINE_R_IN	IN	
11	+5V_AUDIO	PWR	+5V
12	LINE_L_IN	IN	

2.4.9 DDR5 SO-DIMM Channel (CN12)

Standard Specifications.

2.4.10 External +5VSB Input (CN13)

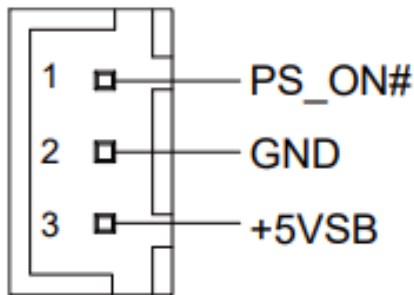

Pin	Pin Name	Signal Type	Signal Level
1	PS_ON#	OUT	+5V
2	GND	GND	
3	+5VSB	PWR	+5V at 2A

2.4.11 GPIO Port (CN18)

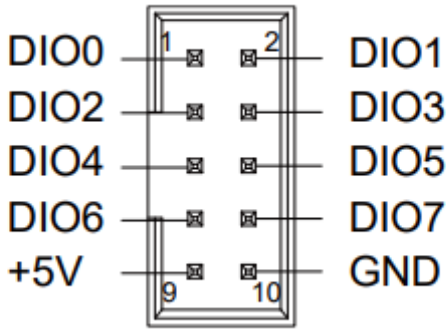

Pin	Pin Name	Signal Type	Signal Level
1	GPIO_0	IN/OUT	
2	GPIO_1	IN/OUT	
3	GPIO_2	IN/OUT	
4	GPIO_3	IN/OUT	
5	GPIO_4	IN/OUT	
6	GPIO_5	IN/OUT	
7	GPIO_6	IN/OUT	
8	GPIO_7	IN/OUT	
9	+V5S	PWR	+5V
10	GND	GND	GND

Note: The driving current of +V5S supports up to 0.5A.

2.4.12 M.2 2230 E-Key (CN21)

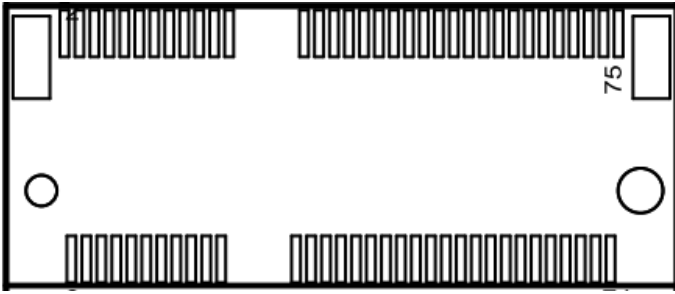

Note: Standard specifications.

2.4.13 LAN Port 1 LED Connector (CN22)

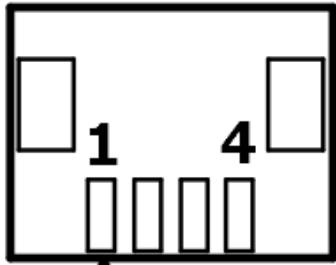

Pin	Pin Name	Signal Type	Signal Level
1	+V3P3A	PWR	+3.3V
2	LAN1_1000#	I/O	
3	LAN1_ACT#	I/O	
4	LAN1_2500#	I/O	

2.4.14 LAN Port 3 LED Connector (CN23)

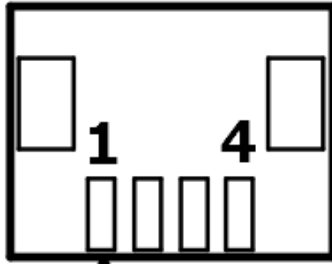

Pin	Pin Name	Signal Type	Signal Level
1	+V3P3A	PWR	+3.3V
2	LAN3_1000#	I/O	
3	LAN3_ACT#	I/O	
4	LAN3_2500#	I/O	

2.4.15 LAN Port 2 LED Connector (CN24)

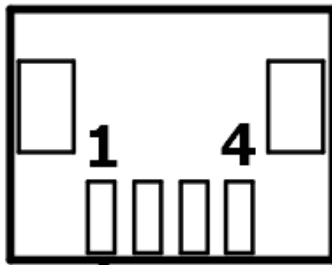

Pin	Pin Name	Signal Type	Signal Level
1	+V3P3A	PWR	+3.3V
2	LAN2_1000#	I/O	
3	LAN2_ACT#	I/O	
4	LAN2_2500#	I/O	

2.4.16 M.2 3052 B-Key (CN25)

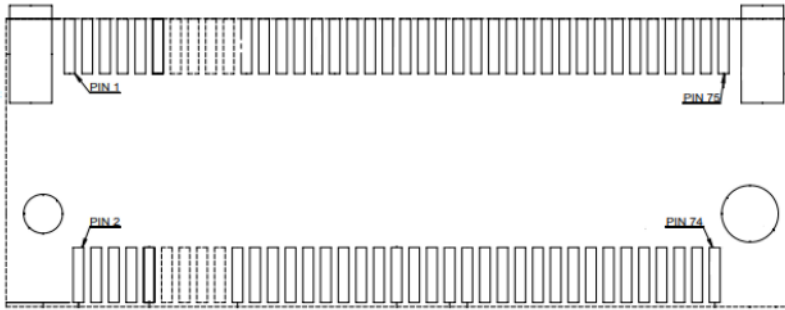

Note: Standard specifications.

2.4.17 Full Size Mini Card Slot/mSATA (CN27)

Pin	Pin Name	Signal Type	Signal Level
1	PCIE_WAKE#	IN	
2	+3.3V	PWR	+3.3V
3	NC	NC	NC
4	GND	GND	GND
5	NC	NC	NC
6	+1.5V	PWR	+1.5V
7	PCIE_CLK_REQ#	IN	
8	NC	NC	NC
9	GND	GND	GND
10	NC	NC	NC
11	PCIE_REF_CLK-	DIFF	
12	NC	NC	NC
13	PCIE_REF_CLK+	DIFF	
14	NC	NC	NC
15	GND	GND	GND
16	NC	NC	NC

Pin	Pin Name	Signal Type	Signal Level
17	NC	NC	NC
18	GND	GND	GND
19	NC	NC	NC
20	W_DISABLE#	OUT	+3.3V
21	GND	GND	GND
22	PCIE_RST#	OUT	+3.3V
23	PCIE_RX-/SATA_RX+	DIFF	GND
24	+3.3V	PWR	+3.3V
25	PCIE_RX+/SATA_RX-	DIFF	
26	GND	GND	GND
27	GND	GND	GND
28	+1.5V	PWR	+1.5V
29	GND	GND	GND
30	SMB_CLK	I/O	+3.3V
31	PCIE_TX-/SATA_TX-	DIFF	
32	SMB_DATA	I/O	+3.3V
33	PCIE_TX+/SATA_TX+	DIFF	
34	GND	GND	GND
35	GND	GND	GND
36	USB_D-	DIFF	
37	GND	GND	GND
38	USB_D+	DIFF	
39	+3.3V	PWR	+3.3V
40	GND	GND	GND
41	+3.3V	PWR	+3.3V
42	NC	NC	NC
43	GND	GND	GND
44	NC	NC	NC
45	NC	NC	NC
46	NC	NC	NC
47	NC	NC	NC
48	+1.5V	PWR	+1.5V
49	NC		

Pin	Pin Name	Signal Type	Signal Level
50	GND	GND	GND
51	NC	NC	NC
52	+3.3V	PWR	+3.3V

Note: Mini Card/mSATA function can be set by BIOS. Default is mSATA.

2.4.18 LVDS 1 Connector (CN28)

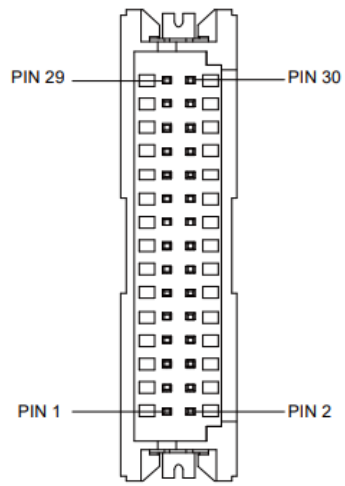

Pin	Pin Name	Signal Type	Signal Level
1	BKL1_ENABLE	OUT	
2	BKL1_CONTROL	OUT	
3	LCD1_PWR	PWR	+3.3V/+5V
4	GND	GND	
5	LVDS1_A_CLK-	DIFF	
6	LVDS1_A_CLK+	DIFF	
7	LCD1_PWR	PWR	+3.3V/+5V
8	GND	GND	
9	LVDS1_DA0-	DIFF	
10	LVDS1_DA0+	DIFF	

Pin	Pin Name	Signal Type	Signal Level
11	LVDS1_DA1-	DIFF	
12	LVDS1_DA1+	DIFF	
13	LVDS1_DA2-	DIFF	
14	LVDS1_DA2+	DIFF	
15	LVDS1_DA3-	DIFF	
16	LVDS1_DA3+	DIFF	
17	DDC1_DATA	I/O	+3.3V
18	DDC1_CLK	I/O	+3.3V
19	LVDS1_DB0-	DIFF	
20	LVDS1_DB0+	DIFF	
21	LVDS1_DB1-	DIFF	
22	LVDS1_DB1+	DIFF	
23	LVDS1_DB2-	DIFF	
24	LVDS1_DB2+	DIFF	
25	LVDS1_DB3-	DIFF	
26	LVDS1_DB3+	DIFF	
27	LCD1_PWR	PWR	+3.3V/+5V
28	GND	GND	
29	LVDS1_B_CLK-	DIFF	
30	LVDS1_B_CLK+	DIFF	

2.4.19 Nano SIM Card Socket (CN29)

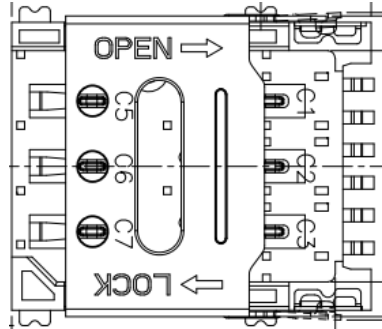

Pin	Pin Name	Signal Type	Signal Level
1	UIM_PWR	PWR	
2	UIM_RST	IN	
3	UIM_CLK	IN	
4	N/A	N/A	
5	GND	GND	GND
6	N/A	N/A	
7	UIM_DATA	I/O	
8	N/A	N/A	

2.4.20 4-pin FAN Connector (CN33)

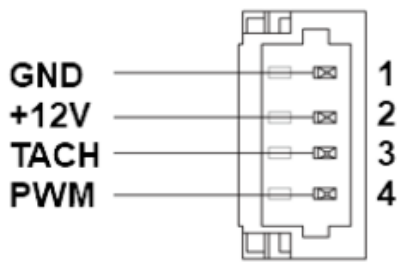

Pin	Pin Name	Signal Type	Signal Level
1	GND	GND	GND
2	FAN_POWER	PWR	+12V
3	FAN_TAC	IN	

Pin	Pin Name	Signal Type	Signal Level
4	FAN_CTL		

Note: The driving current of FAN_POWER supports up to 1A.

2.4.21 LVDS Inverter/Backlight Connector (CN34)

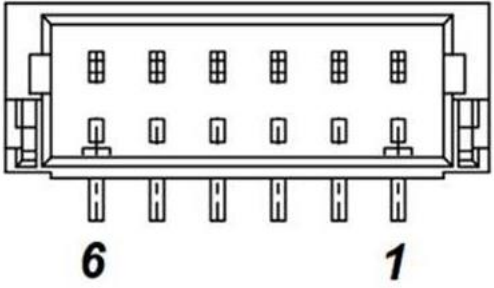

Pin	Pin Name	Signal Type	Signal Level
1	BKL1_PWR	PWR	+5V(Default)/+12V
2	BKL1_PWR	PWR	+5V(Default)/+12V
3	BK1L_CONTROL	OUT	
4	GND	GND	
5	GND	GND	
6	BKL1_ENABLE	OUT	+3.3V

Note: LVDS/BKL_PWR can be set to +12V or +5V by JP4.

Note: The driving current of BKL_PWR supports up to 2A.

2.4.22 RJ-45 LAN Port 3 (CN35)

LAN3

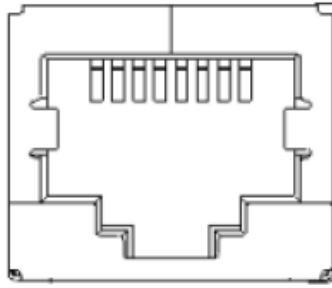

Pin	Pin Name	Signal Type	Signal Level
1	MDI0+	DIFF	
2	MDI0-	DIFF	
3	MDI1+	DIFF	
4	MDI2+	DIFF	
5	MDI2-	DIFF	
6	MDI1-	DIFF	
7	MDI3+	DIFF	
8	MDI3-	DIFF	

2.4.23 RJ-45 LAN Port 1/Port 2 (CN36)

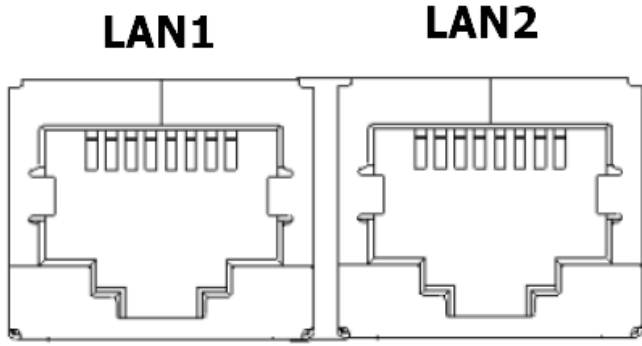

Pin	Pin Name	Signal Type	Signal Level
1P1	LAN2_MDI0_P	DIFF	
1P2	LAN2_MDI0_N	DIFF	
1P3	LAN2_MDI1_P	DIFF	
1P4	LAN2_MDI1_N	DIFF	
1P7	LAN2_MDI2_P	DIFF	
1P8	LAN2_MDI2_N	DIFF	
1P9	LAN2_MDI3_P	DIFF	
1P10	LAN2_MDI3_N	DIFF	
2P1	LAN1_MDI0_P	DIFF	
2P2	LAN1_MDI0_N	DIFF	
2P3	LAN1_MDI1_P	DIFF	
2P4	LAN1_MDI1_N	DIFF	
2P7	LAN1_MDI2_P	DIFF	
2P8	LAN1_MDI2_N	DIFF	
2P9	LAN1_MDI3_P	DIFF	
2P10	LAN1_MDI3_N	DIFF	

2.4.24 USB 3.2/USB 2.0 Port 1/Port 2 (CN37)

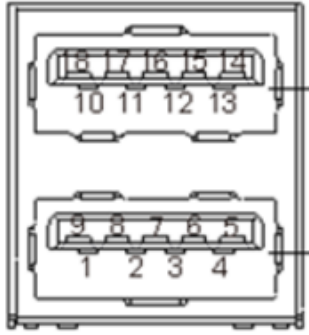

Pin	Pin Name	Signal Type	Signal Level
1	+5VSB	PWR	+5V
2	USB2_1_DN	DIFF	
3	USB2_1_DP	DIFF	
4	GND	GND	GND
5	USB3_1_RXN	DIFF	
6	USB3_1_RXP	DIFF	
7	GND	GND	GND
8	USB3_1_TXN	DIFF	
9	USB3_1_TXP	DIFF	
10	+5VSB	PWR	+5V
11	USB2_2_DN	DIFF	
12	USB2_2_DP	DIFF	
13	GND	GND	GND
14	USB3_2_RXN	DIFF	
15	USB3_2_RXP	DIFF	
16	GND	GND	GND
17	USB3_2_TXN	DIFF	
18	USB3_2_TXP	DIFF	

Note: The driving current of +5VSB supports up to 0.9A/Port.

2.4.25 RTC Battery Connector (CN39)

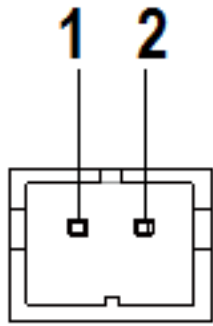

Pin	Pin Name	Signal Type	Signal Level
1	+3.3V	PWR	+3.3V
2	GND	GND	GND

2.4.26 CRT Connector (CN40)

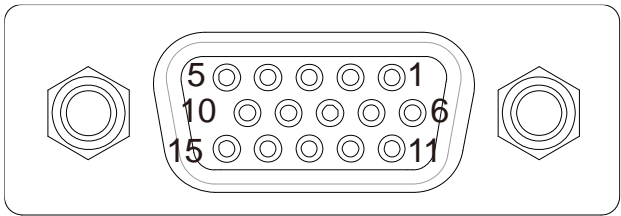

Pin	Pin Name	Signal Type	Signal Level
1	RED	OUT	
2	GREEN	OUT	
3	BLUE	OUT	
4	NC	NC	
5	GND	GND	
6	RED_GND_RTN	GND	
7	GREEN_GND_RTN	GND	
8	BLUE_GND_RTN	GND	
9	+5V	PWR	+5V

Pin	Pin Name	Signal Type	Signal Level
10	GND	GND	
11	NC	NC	
12	DDC_DATA	I/O	+5V
13	HSYNC	OUT	
14	VSYNC	OUT	
15	DDC_CLK	I/O	+5V

2.4.27 I2C/SMBus Connector (CN42)

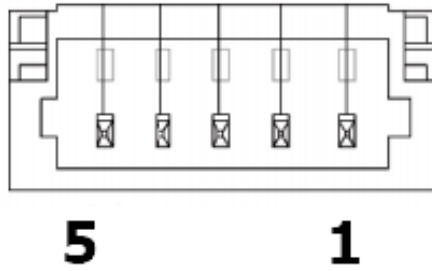

Pin	Pin Name	Signal Type	Signal Level
1	+V3P3A/ +V3P3S	PWR	+3.3V
2	SMB_CLK/ I2C_CLK/TIME_SYNC0	OUT	
3	SMB_DAT/ I2C_DAT/TIME_SYNC1	I/O	
4	SMB_ALERT/ INT_SERIRQ/LAN_SDP	IN	
5	GND	GND	GND

2.4.28 HDMI Connector (CN43)

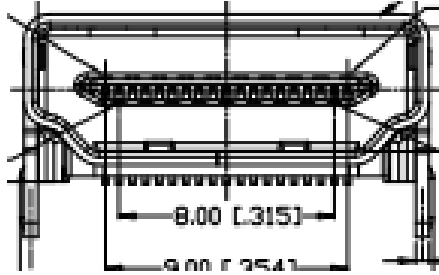

Pin	Pin Name	Signal Type	Signal Level
1	HDMI_TX2+	DIFF	
2	GND	GND	GND
3	HDMI_TX2-	DIFF	
4	HDMI_TX1+	DIFF	
5	GND	GND	GND
6	HDMI_TX1-	DIFF	
7	HDMI_TX0+	DIFF	
8	GND	GND	GND
9	HDMI_TX0-	DIFF	
10	HDMI_CLK+	DIFF	
11	GND	GND	GND
12	HDMI_CLK-	DIFF	
13	N/A	N/A	N/A
14	N/A	N/A	N/A
15	DDC_CLK	I/O	
16	DDC_DATA	I/O	
17	GND	GND	GND
18	+V5S	PWR	+5V
19	HDMI_HPD	IN	

2.4.29 COM Port 1 (CN44)

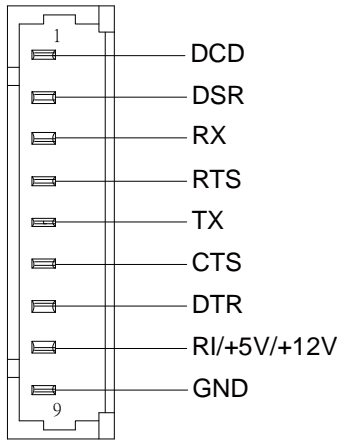

RS-232

Pin	Pin Name	Signal Type	Signal Level
1	DCD	IN	
2	DSR	IN	
3	RX	IN	
4	RTS	OUT	±9V
5	TX	OUT	±9V
6	CTS	IN	
7	DTR	OUT	±9V
8	RI/+5V/+12V	IN/ PWR	+5V/+12V
9	GND	GND	

RS-485

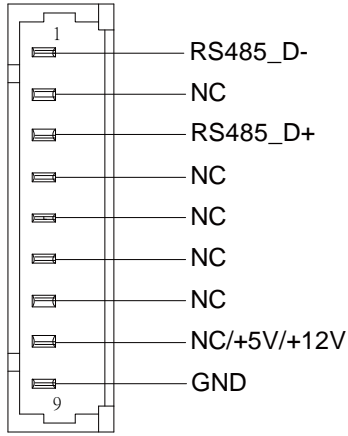

RS-485

Pin	Pin Name	Signal Type	Signal Level
1	RS485_D-	I/O	±5V
2	NC		
3	RS485_D+	I/O	±5V
4	NC		
5	NC		
6	NC		
7	NC		
8	NC/+5V/+12V	PWR	+5V/+12V
9	GND	GND	

RS-422

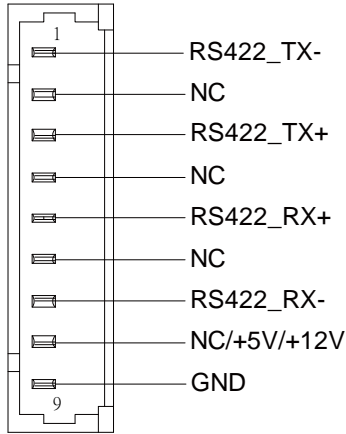

RS-422

Pin	Pin Name	Signal Type	Signal Level
1	RS422_TX-	OUT	±5V
2	NC		
3	RS422_TX+	OUT	±5V
4	NC		
5	RS422_RX+	IN	
6	NC		
7	RS422_RX-	IN	
8	NC/+5V/+12V	PWR	+5V/+12V
9	GND	GND	

Note: COM1 RS-232/422/485 can be set by BIOS setting. Default is RS-232.

Note: Pin 8 function can be set by JP2.

2.4.30 COM Port 2 (CN45)

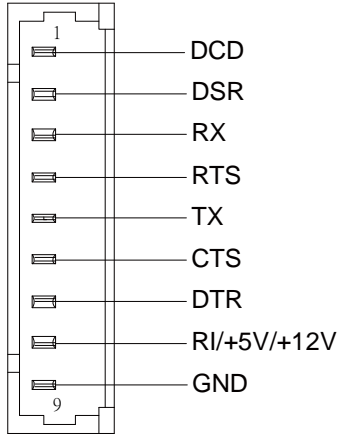

RS-232			
Pin	Pin Name	Signal Type	Signal Level
1	DCD	IN	
2	DSR	IN	
3	RX	IN	
4	RTS	OUT	±9V
5	TX	OUT	±9V
6	CTS	IN	
7	DTR	OUT	±9V
8	RI/+5V/+12V	IN/ PWR	+5V/+12V
9	GND	GND	

RS-485

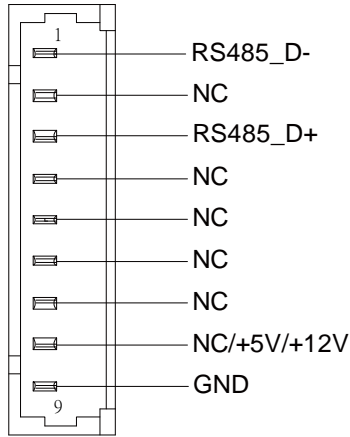

RS-485

Pin	Pin Name	Signal Type	Signal Level
1	RS485_D-	I/O	±5V
2	NC		
3	RS485_D+	I/O	±5V
4	NC		
5	NC		
6	NC		
7	NC		
8	NC/+5V/+12V	PWR	+5V/+12V
9	GND	GND	

RS-422

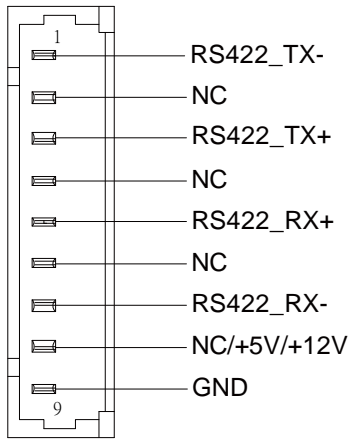

RS-422

Pin	Pin Name	Signal Type	Signal Level
1	RS422_TX-	OUT	±5V
2	NC		
3	RS422_TX+	OUT	±5V
4	NC		
5	RS422_RX+	IN	
6	NC		
7	RS422_RX-	IN	
8	NC/+5V/+12V	PWR	+5V/+12V
9	GND	GND	

Note: COM2 RS-232/422/485 can be set by BIOS setting. Default is RS-232.

Note: Pin 8 function can be set by JP1.

2.4.31 COM Port 3 (CN46)

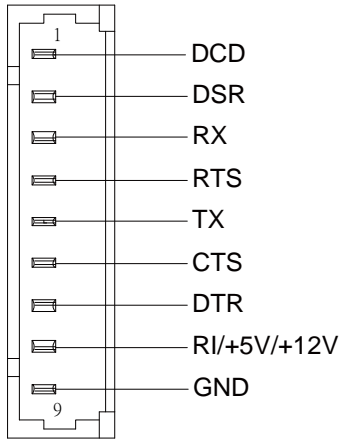

RS-232

Pin	Pin Name	Signal Type	Signal Level
1	DCD	IN	
2	DSR	IN	
3	RX	IN	
4	RTS	OUT	±9V
5	TX	OUT	±9V
6	CTS	IN	
7	DTR	OUT	±9V
8	RI	IN	
9	GND	GND	

2.4.32 COM Port 4 (CN47)

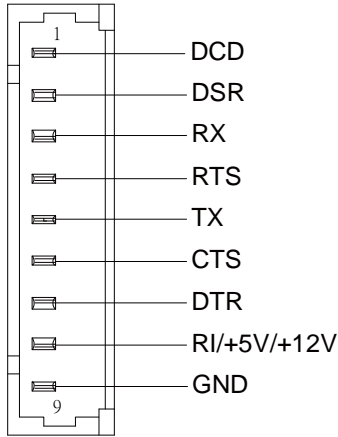

RS-232

Pin	Pin Name	Signal Type	Signal Level
1	DCD	IN	
2	DSR	IN	
3	RX	IN	
4	RTS	OUT	±9V
5	TX	OUT	±9V
6	CTS	IN	
7	DTR	OUT	±9V
8	RI	IN	
9	GND	GND	

2.4.33 USB 2.0 Port 3 (CN48)

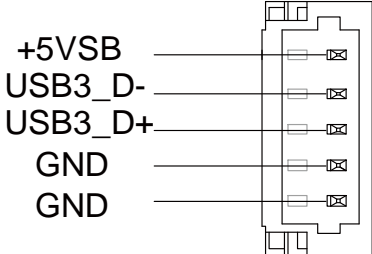

Pin	Pin Name	Signal Type	Signal Level
1	+5VSB	PWR	+5V
2	USB_D-	DIFF	
3	USB_D+	DIFF	
4	GND	GND	
5	GND	GND	

2.4.34 USB 2.0 Port 4 (CN49)

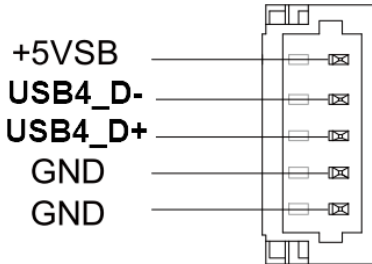

Pin	Pin Name	Signal Type	Signal Level
1	+5VSB	PWR	+5V
2	USB_D-	DIFF	
3	USB_D+	DIFF	
4	GND	GND	
5	GND	GND	

2.4.35 USB 2.0 Port 5 (CN50)

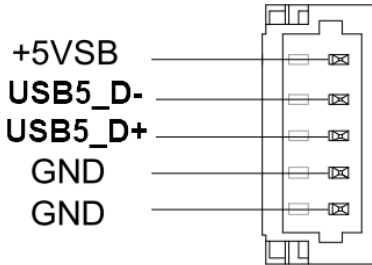

Pin	Pin Name	Signal Type	Signal Level
1	+5VSB	PWR	+5V
2	USB_D-	DIFF	
3	USB_D+	DIFF	
4	GND	GND	
5	GND	GND	

2.4.36 USB 2.0 Port 6 (CN53)

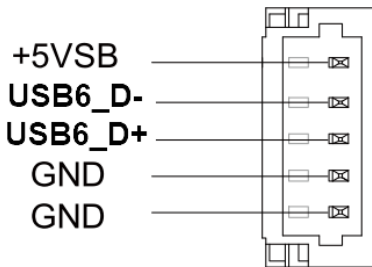

Pin	Pin Name	Signal Type	Signal Level
1	+5VSB	PWR	+5V
2	USB_D-	DIFF	
3	USB_D+	DIFF	
4	GND	GND	
5	GND	GND	

2.5 Thermal Solutions

2.5.1 Heatspreader - GENE-ADN6-HSP01

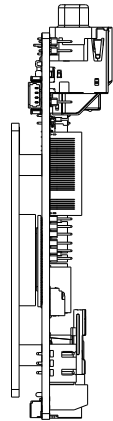
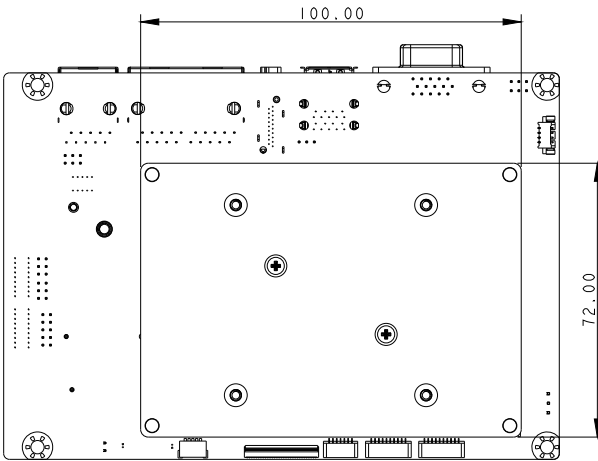
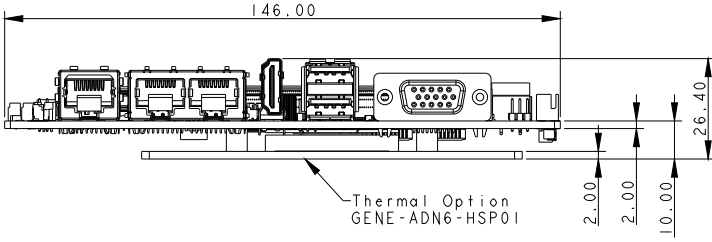

GENE-ADN6-HSP01 Assembly

3.5" Subcompact Board

GENE-ADN6

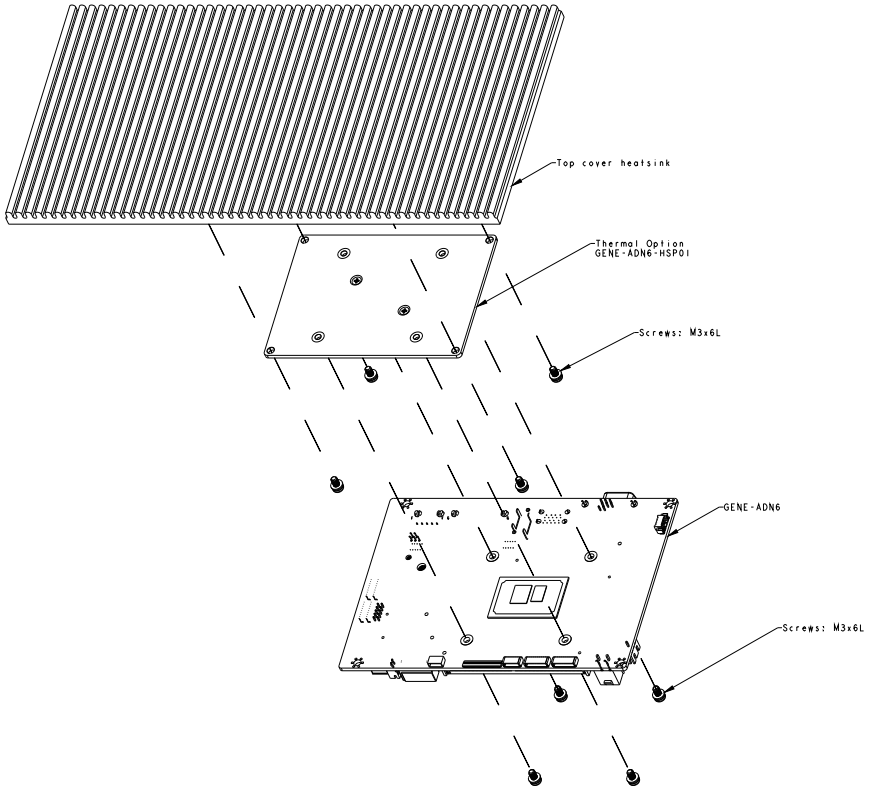

2.5.2 Heatsink Option 1- GENE-ADN6-HSK01

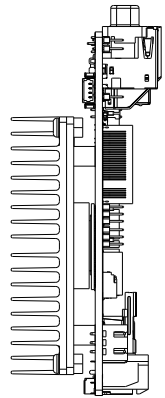
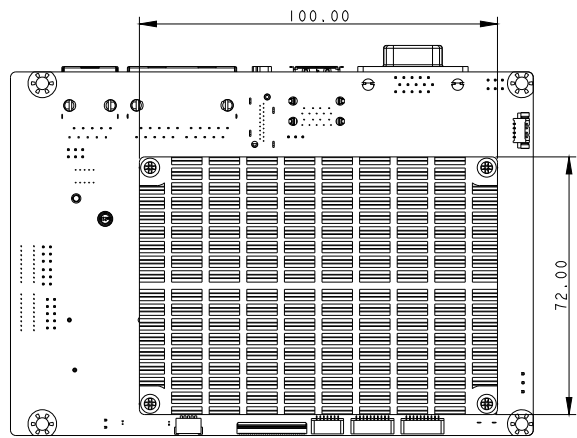
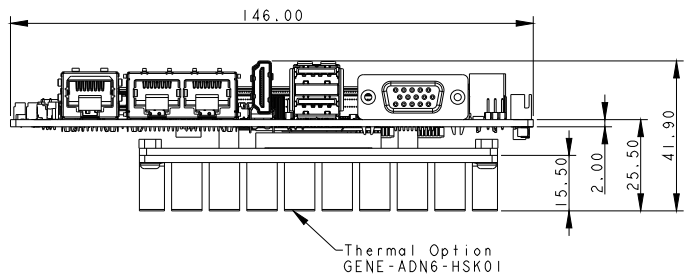

GENE-ADN6-HSK01 Assembly

3.5" Subcompact Board

GENE-ADN6

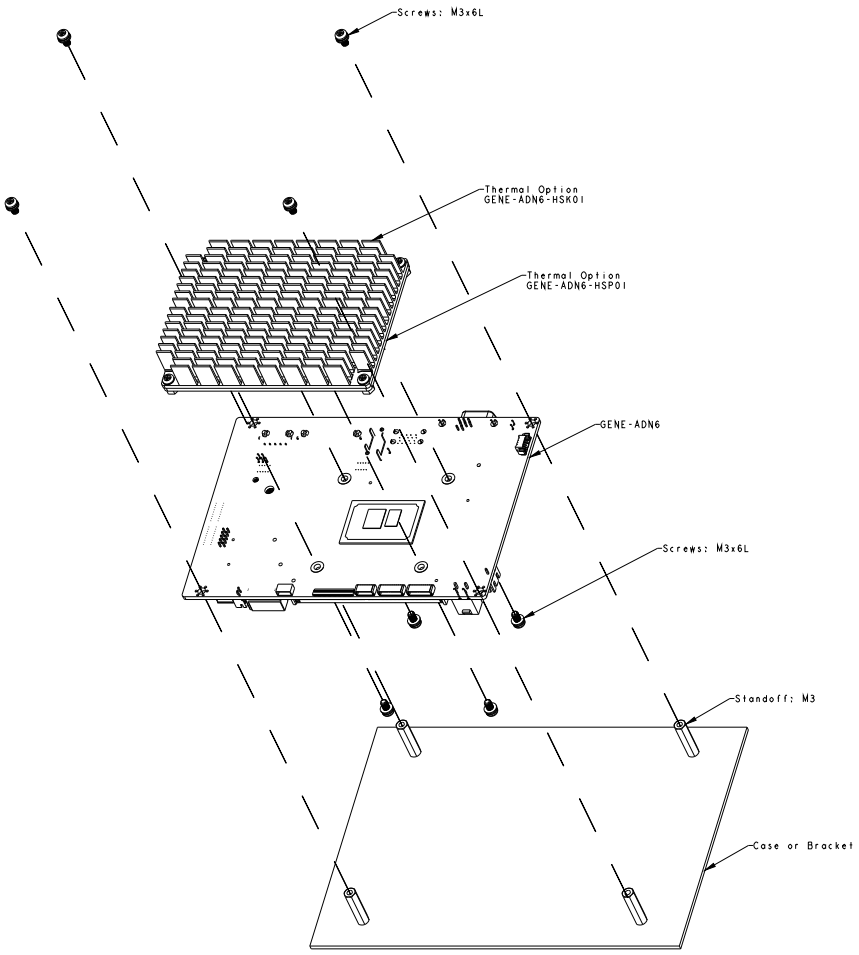

2.5.3 Heatsink Option 2- GENE-ADN6-HSK02

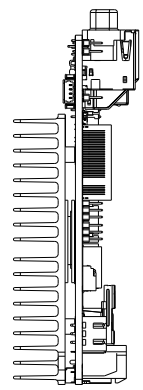
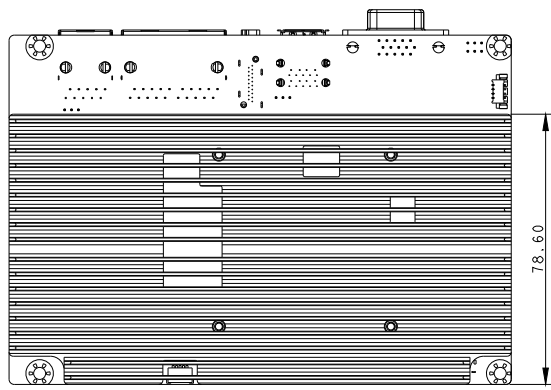
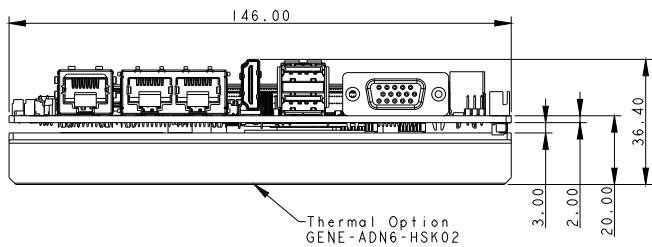

GENE-ADN6-HSK02 Assembly

3.5" Subcompact Board

GENE-ADN6

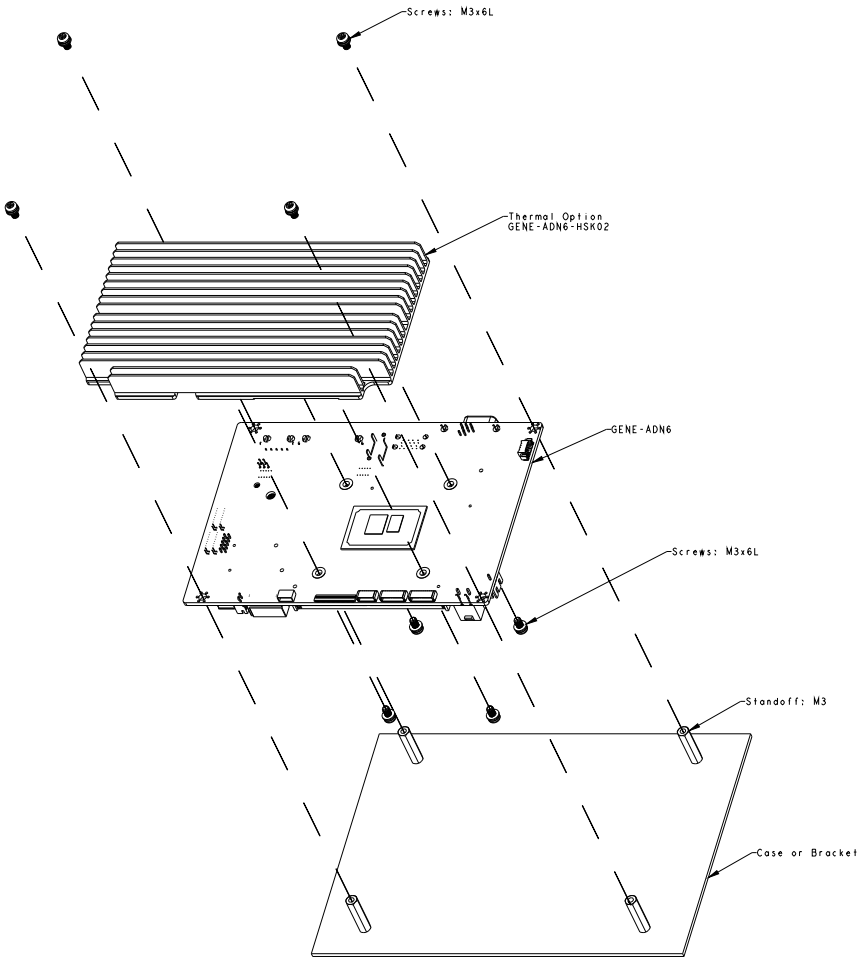

Chapter 3

AMI BIOS Setup

3.1 System Test and Initialization

These routines check the current system configuration stored in the CMOS memory and BIOS NVRAM. If system configuration is not found or system configuration data error is detected, system will load optimized default and re-boot with this default system configuration automatically.

There are four situations in which you will need to setup system configuration:

1. You are starting your system for the first time
2. You have changed the hardware attached to your system
3. The system configuration is reset by Clear-CMOS jumper
4. The CMOS memory has lost power and the configuration information has been erased.

The EPIC-ADN9 CMOS memory has an integral lithium battery backup for data retention. However, you will need to replace the complete unit when it finally runs down.

3.2 AMI BIOS Setup

AMI BIOS ROM has a built-in Setup program that allows users to modify the basic system configuration. This type of information is stored in battery-backed CMOS RAM and BIOS NVRAM so that it retains the Setup information when the power is turned off.

Entering Setup

Power on the computer and press or <ESC> immediately. This will allow you to enter Setup.

Main

Set the date, use tab to switch between date elements.

Advanced

Enable/disable boot option for legacy network devices.

Chipset

Host bridge parameters.

Boot

Enables/disables quiet boot option.

Security

Set setup administrator password.

Save & Exit

Exit system setup after saving the changes.

Intel® AMT Configuration

Configure user content preferences.

3.3 Setup Submenu: Main



3.4 Setup Submenu: Advanced

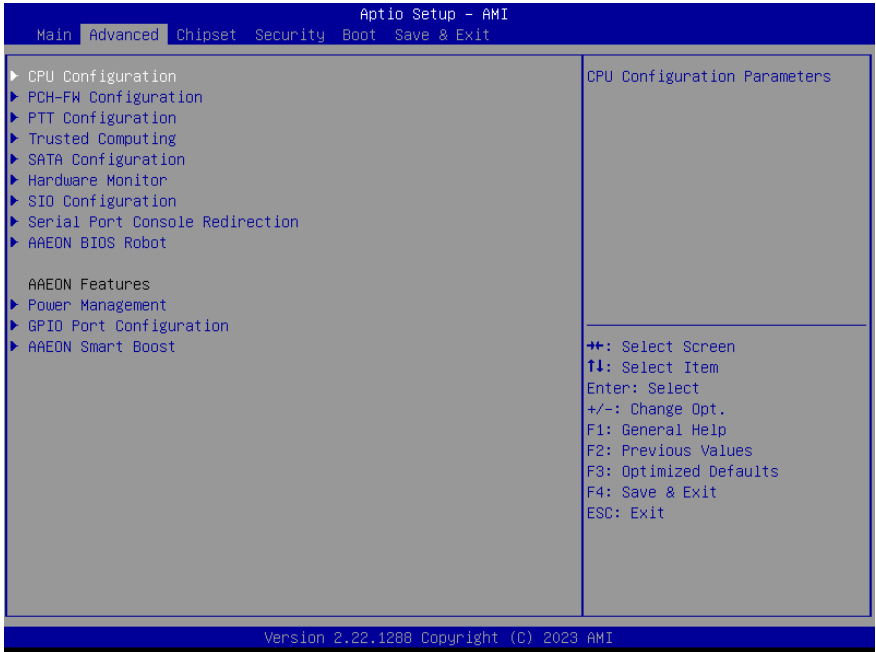

3.4.1 CPU Configuration

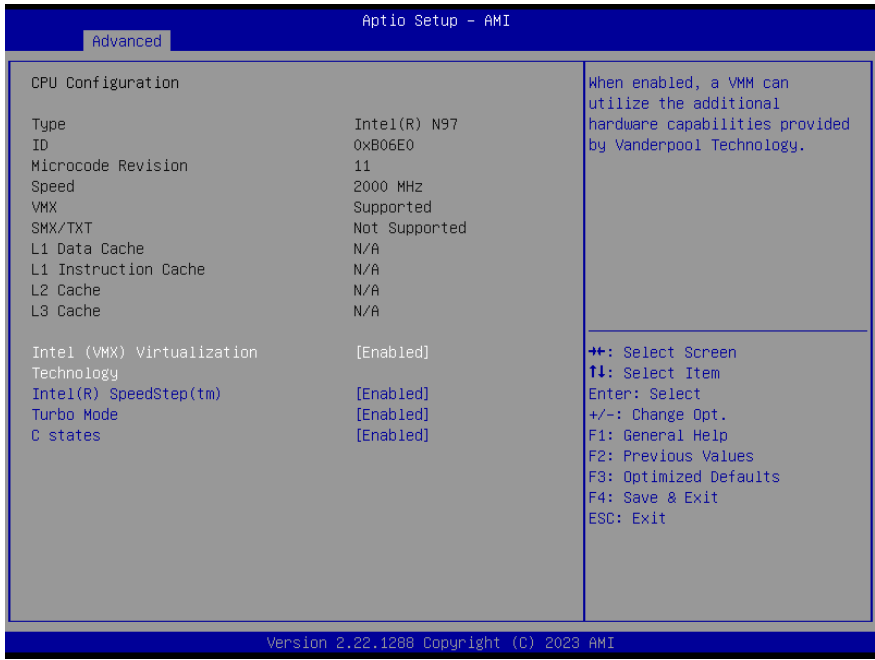

Options Summary		
Intel (VMX) Virtualization Technology	Disabled	
	Enabled	Optimal Default, Failsafe Default
When enabled, a VMM can utilize the additional hardware capabilities provided by Vanderpool Technology.		
Intel® SpeedStep™	Disabled	
	Enabled	Optimal Default, Failsafe Default
Allows more than two frequency ranges to be supported.		
Turbo Mode	Disabled	
	Enabled	Optimal Default, Failsafe Default
Enable or Disable processor Turbo Mode (requires EMTTM enable too). AUTO means enabled.		
C states	Disabled	
	Enabled	Optimal Default, Failsafe Default
Enable/Disable CPU Power Management. Allows CPU to go to C states when it's not 100 utilized.		

3.4.2 PCH-FW Configuration

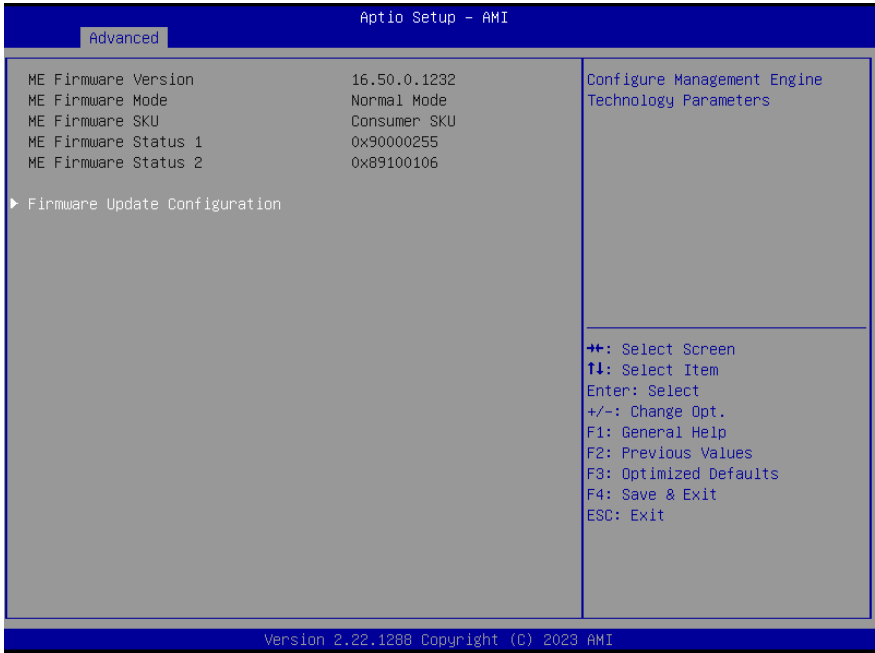

3.4.3 Firmware Update Configuration

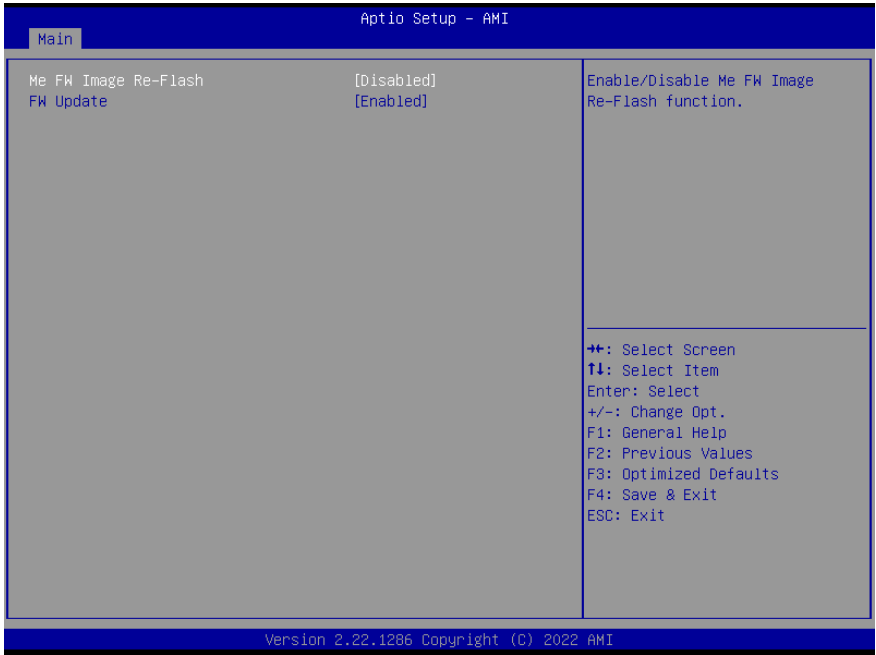

Options Summary		
Me FW Image Re-Flash	Enabled	
	Disabled	Optimal Default, Failsafe Default
Enable/Disable Me FW Image Re-Flash function.		
FW Update	Disabled	
	Enabled	Optimal Default, Failsafe Default
Enable/Disable ME FW Update function.		

3.4.4 PTT Configuration



Options Summary		
TPM Device Selection	dTPM	Optimal Default, Failsafe Default
	PTT	
<p>Selects TPM device: PTT or discrete TPM. PTT - enables PTT in SkuMgr. dTPM - disables PTT in SkuMgr. Warning! PTT/dTPM will be disabled and all data saved on it will be lost.</p>		

3.4.5 Trusted Computing

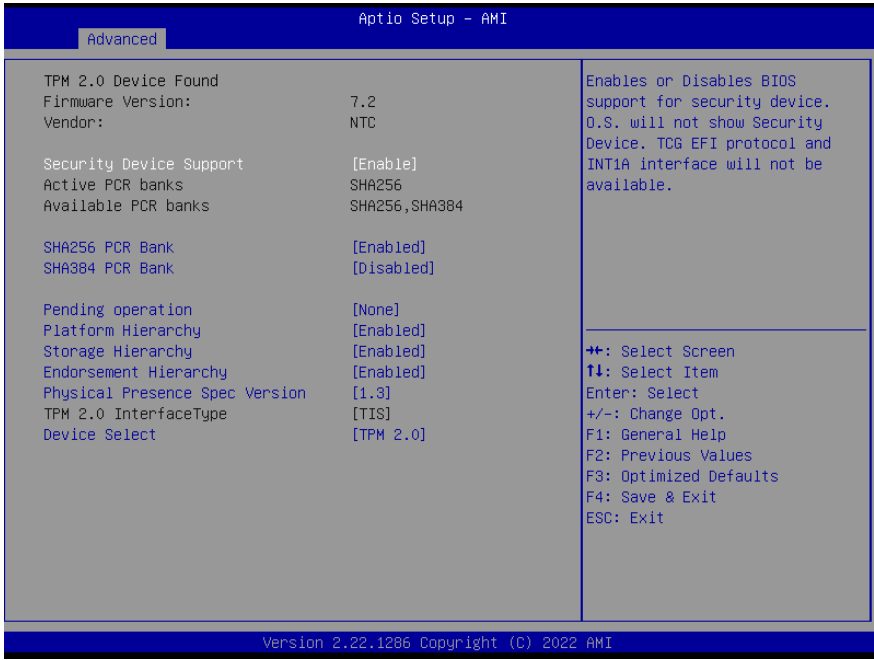

Options Summary		
Security Device Support	Enable	Optimal Default, Failsafe Default
	Disable	
Enables or Disables BIOS support for security device. O.S. will not show Security Device. TCG EFI protocol and INT1A interface will not be available.		
SHA256 PCR Bank	Enabled	Optimal Default, Failsafe Default
	Disabled	
Enable or Disable SHA256 PCR Bank.		
SHA384 PCR Bank	Enabled	Optimal Default, Failsafe Default
	Disabled	
Enable or Disable SHA384 PCR Bank.		
Pending operation	None	Optimal Default, Failsafe Default
	TPM Clear	
Schedule an Operation for the Security Device.		
NOTE: Your Computer will reboot during restart in order to change State of Security Device.		

Options Summary		
Platform Hierarchy	Enabled	Optimal Default, Failsafe Default
	Disabled	
Enable or Disable Platform Hierarchy.		
Storage Hierarchy	Enabled	Optimal Default, Failsafe Default
	Disabled	
Enable or Disable Storage Hierarchy.		
Endorsement Hierarchy	Enabled	Optimal Default, Failsafe Default
	Disabled	
Enable or Disable Endorsement Hierarchy.		
Physical Presence Spec Version	1.3	Optimal Default, Failsafe Default
	1.2	
Select to Tell O.S. to support PPI Spec Version 1.2 or 1.3. Note some HCK tests might not support 1.3.		
Physical Presence Spec Version	Auto	
	TPM 1.2	
	TPM 2.0	Optimal Default, Failsafe Default
TPM 1.2 will restrict support to TPM 1.2 devices. TPM 2.0 will restrict support to TPM 2.0 devices. Auto will support both with the default set to TPM 2.0 devices if not found. TPM 1.2 devices will be enumerated.		

3.4.6 SATA Configuration

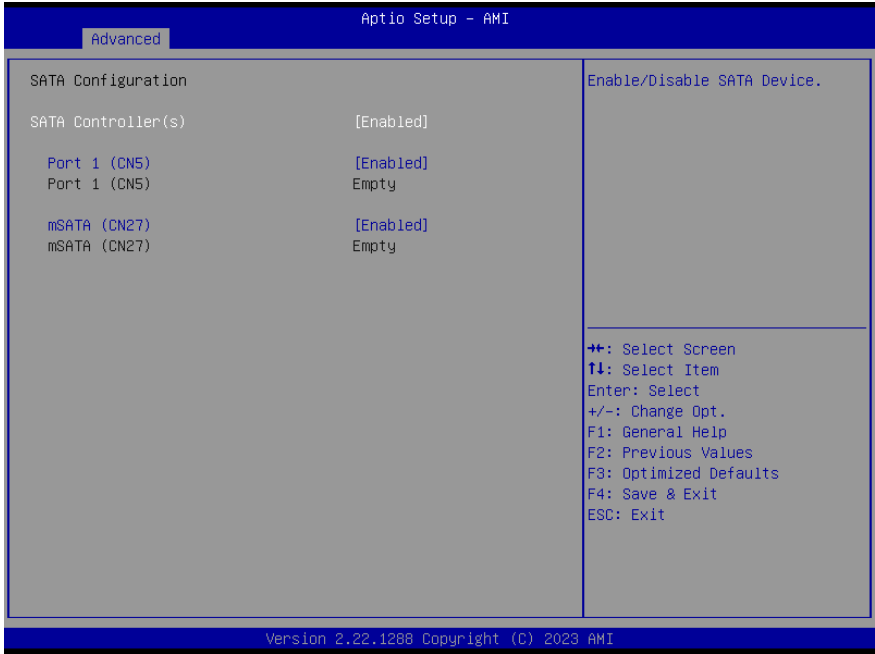

Options Summary		
SATA Controller(s)	Enabled	Optimal Default, Failsafe Default
	Disabled	
Enable/Disable SATA Device.		
Port 1(CN5)	Enabled	Optimal Default, Failsafe Default
	Disabled	
Enable or Disable SATA Port.		
mSATA (CN27)	Enabled	Optimal Default, Failsafe Default
	Disabled	
Enable or Disable SATA Port.		

3.4.7 Hardware Monitor

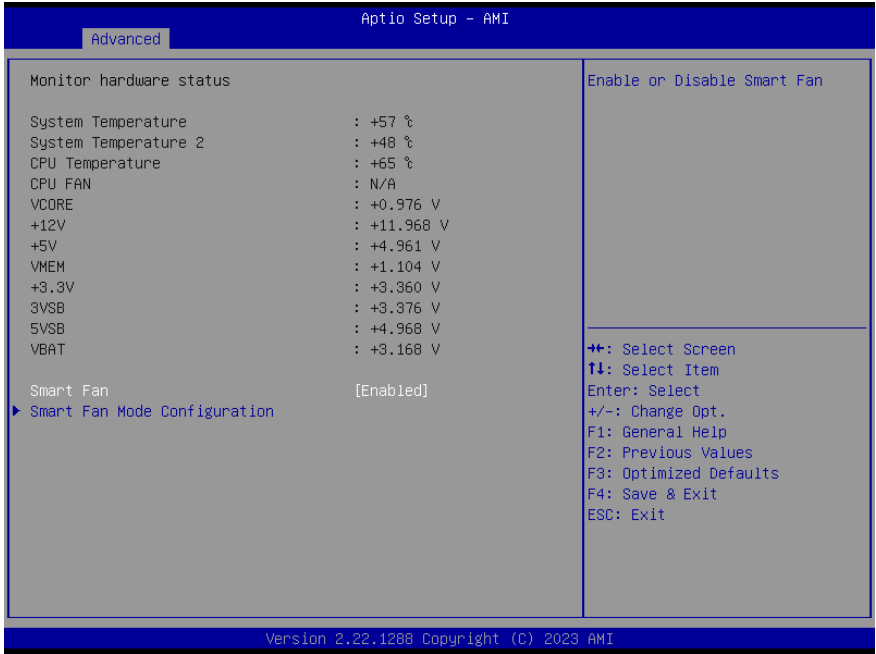

Options Summary		
Smart Fan	Disable	
	Enable	Optimal Default, Failsafe Default
Enables or Disables Smart Fan.		

3.4.7.1 Smart Fan Mode Configuration

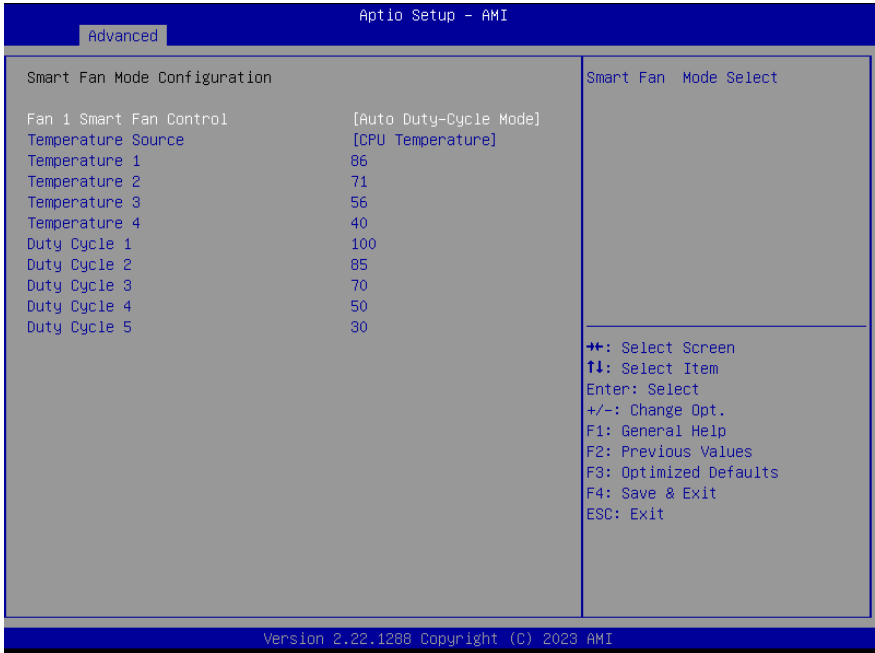

Options Summary		
Fan 1 Smart Fan Control	Manual Duty Mode	
	Auto Duty-Cycle Mode	Optimal Default, Failsafe Default
Smart Fan Mode Select.		
Temperature Source	CPU Temperature	Optimal Default, Failsafe Default
	System Temperature	
	System Temperature 2	
Select the monitored temperature source for this fan.		
Temperature 1	86	
Duty Cycle 1	100	
Auto fan speed control. Fan speed will follow different temperature by different duty cycle 1-100.		

3.4.8 SIO Configuration



3.4.8.1 Serial Port 1 Configuration

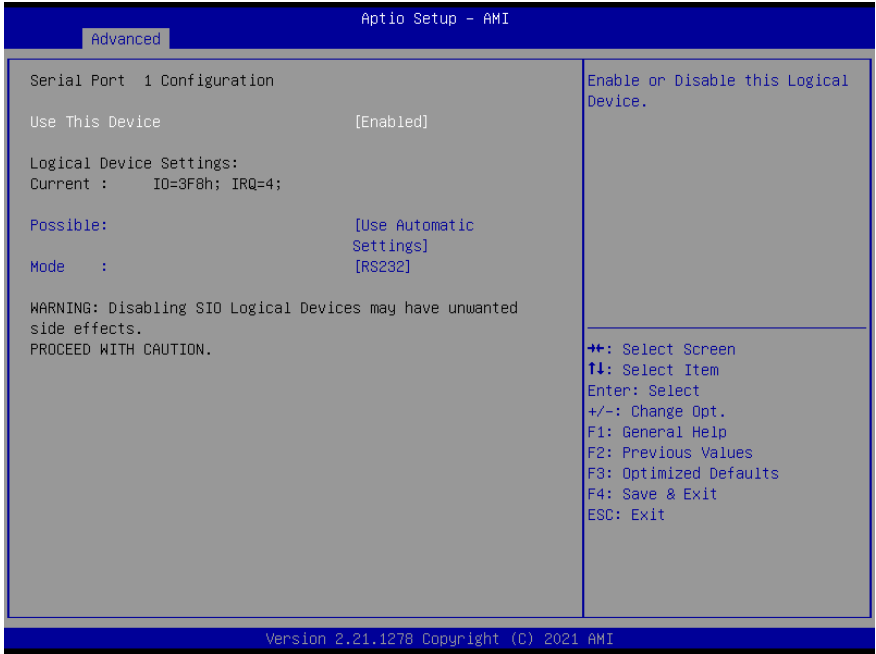

Options Summary		
Use This Device	Disable	
	Enable	Optimal Default, Failsafe Default
Enable or Disable this Logical Device.		
Possible:	Use Automatic Settings	Optimal Default, Failsafe Default
	IO=3F8h; IRQ=4	
	IO=2F8h; IRQ=3	
Allows user to change Device's Resource settings. New settings will be reflected on This Setup Page after System restarts.		
Mode:	RS232	Optimal Default, Failsafe Default
	RS422	
	RS485	
UART RS232, 422, 485 selection.		

3.4.8.2 Serial Port 2 Configuration

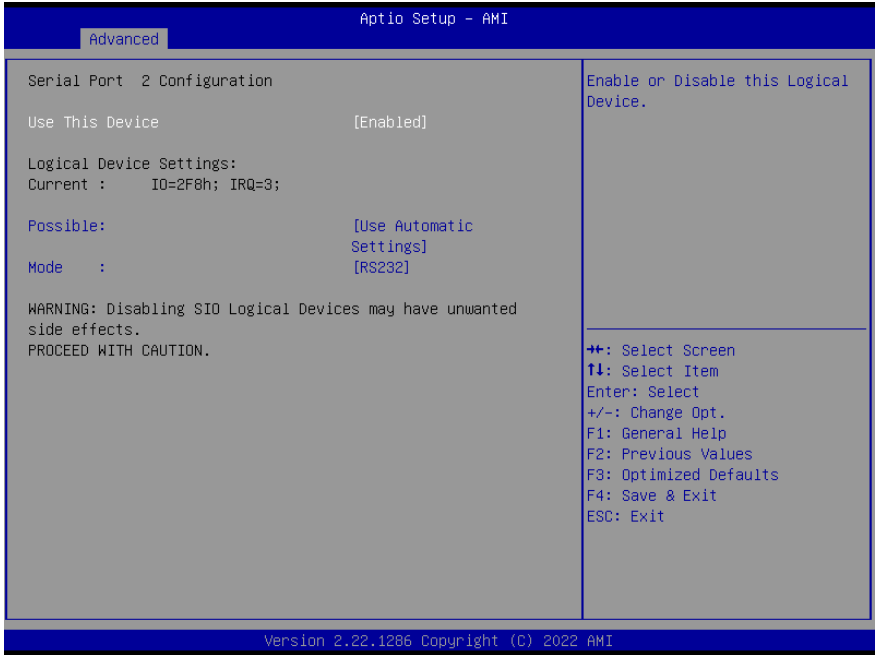

Options Summary		
Use This Device	Disable	
	Enable	Optimal Default, Failsafe Default
Enable or Disable this Logical Device.		
Possible:	Use Automatic Settings	Optimal Default, Failsafe Default
	IO=2F8h; IRQ=3	
	IO=3F8h; IRQ=4	
Allows user to change Device's Resource settings. New settings will be reflected on This Setup Page after System restarts.		
Mode:	RS232	Optimal Default, Failsafe Default
	RS422	
	RS485	
UART RS232, 422, 485 selection.		

3.4.8.3 Serial Port 3 Configuration

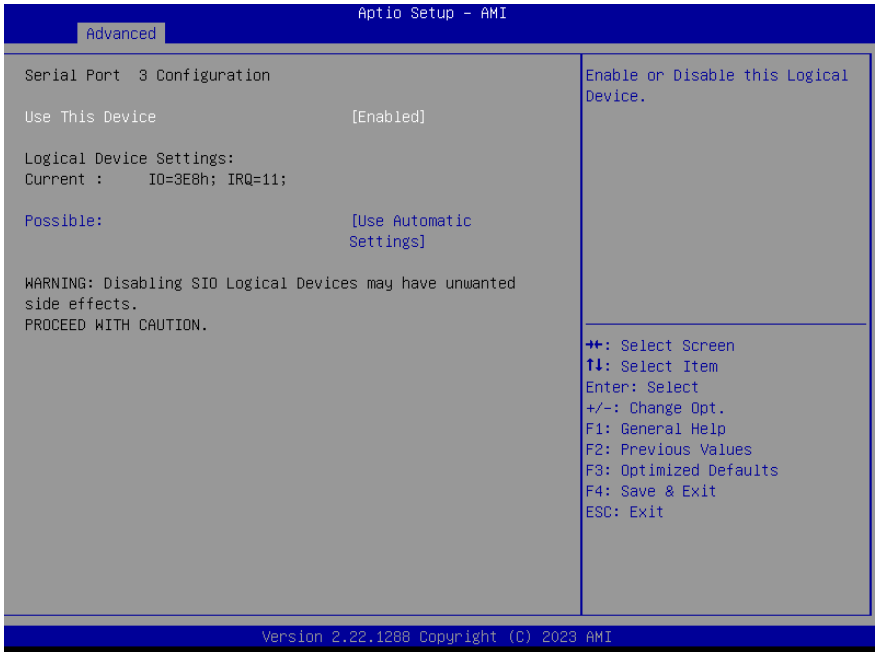

Options Summary		
Use This Device	Disable	
	Enable	Optimal Default, Failsafe Default
Enable or Disable this Logical Device.		
Possible:	Use Automatic Settings	Optimal Default, Failsafe Default
	IO=3E8h; IRQ=11	
	IO=2E8h; IRQ=11	
Allows user to change Device's Resource settings. New settings will be reflected on This Setup Page after System restarts.		

3.4.8.4 Serial Port 4 Configuration

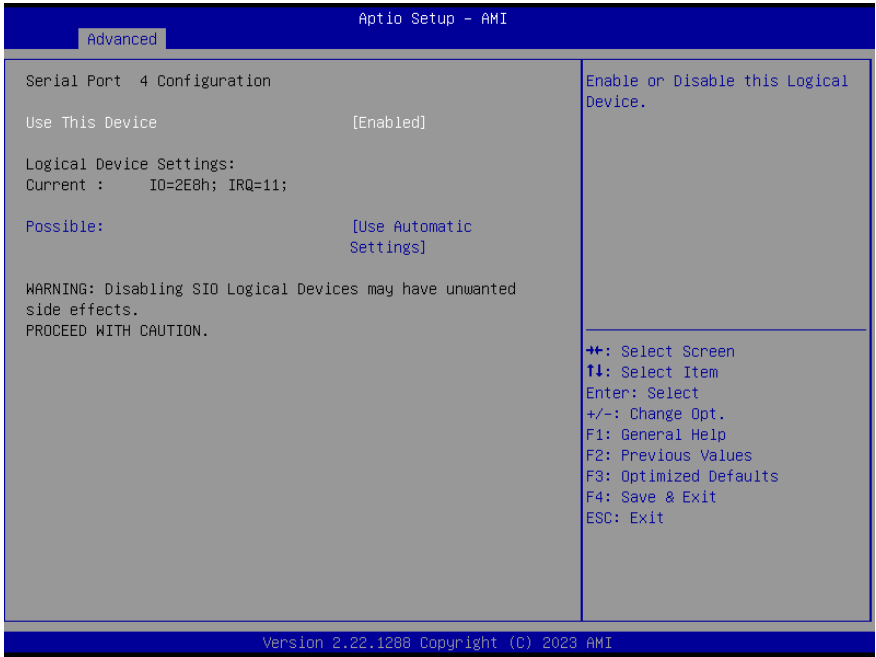

Options Summary		
Use This Device	Disable	
	Enable	Optimal Default, Failsafe Default
Enable or Disable this Logical Device.		
Possible:	Use Automatic Settings	Optimal Default, Failsafe Default
	IO=2E8h; IRQ=11	
	IO=3E8h; IRQ=11	
Allows user to change Device's Resource settings. New settings will be reflected on This Setup Page after System restarts.		

3.4.9 Serial Port Console Redirection

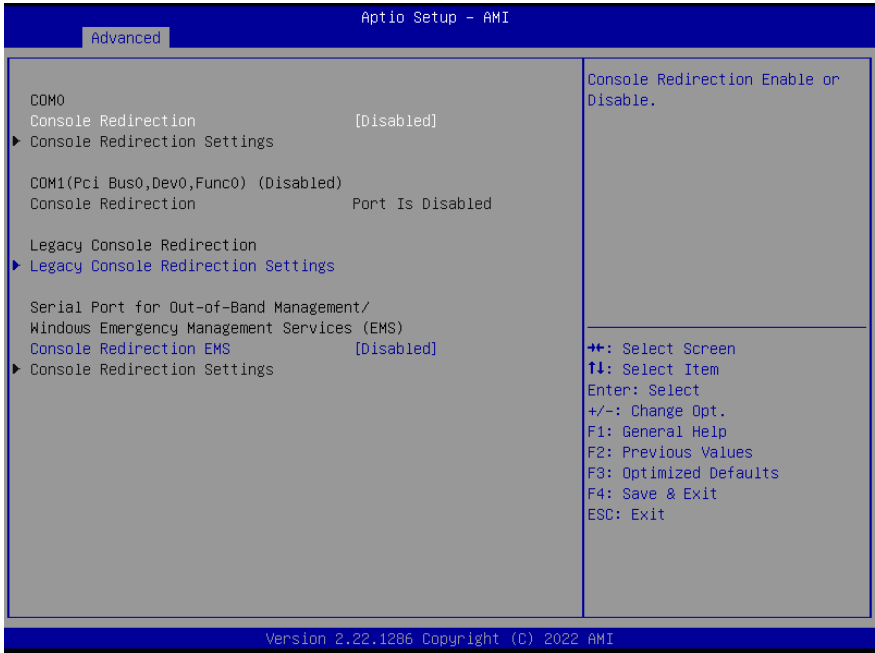

Options Summary		
Console Redirection	Disabled	Optimal Default, Failsafe Default
	Enabled	
Console Redirection Enable or Disable.		
Console Redirection EMS	Disabled	Optimal Default, Failsafe Default
	Enabled	
Console Redirection Enable or Disable.		

3.4.10 Legacy Console Redirection Settings

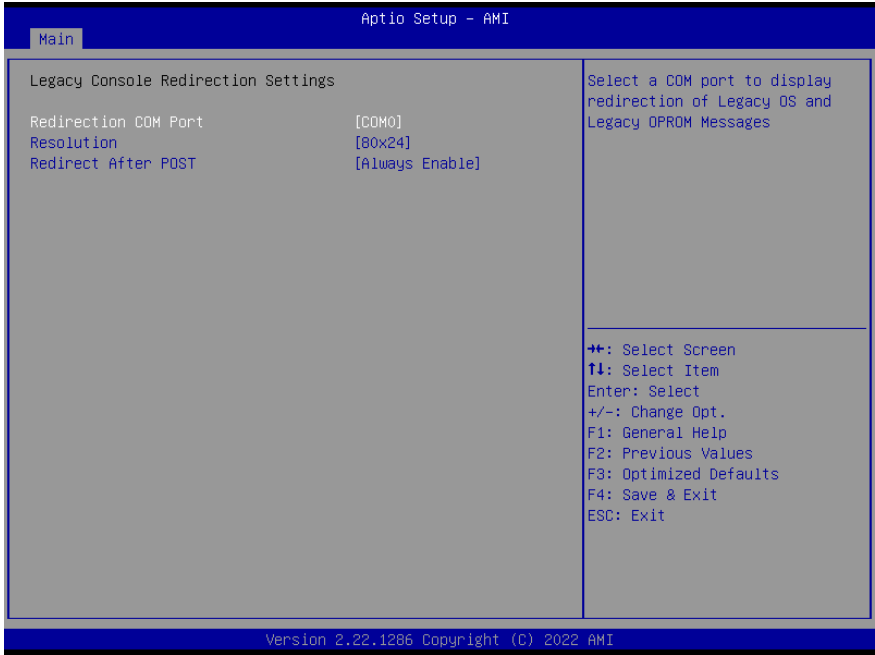

Options Summary		
Redirection COM port	COM0	Optimal Default, Failsafe Default
	COM1(Pci Bus0, Dev0, Func0) (Disabled)	
Select a COM Port to display redirection of Legacy OS and Legacy OPROM message.		
Resolution	80x24	Optimal Default, Failsafe Default
	80x25	
On Legacy OS, the number of Rows and Columns supported redirection.		
Redirect After POST	Always Enable	Optimal Default, Failsafe Default
	BootLoader	
When Bootloader is selected, then Legacy Console Redirection is disabled before booting to legacy OS. When Always Enable is selected, then Legacy Console Redirection is enabled for legacy OS. Default setting for this option is set to Always Enable.		

3.4.11 AAEON BIOS Robot



Options Summary		
Sends watch dog before BIOS POST	Disabled	Optimal Default, Failsafe Default
	Enabled	
Enabled - Robot set Watch Dog Timer (WDT) right after power on, before BIOS start POST process. And then Robot will clear WDT on completion of POST. WDT will reset system automatically if it is not cleared before its timer counts down to zero.		
POST Timer (second)	30	Optimal Default, Failsafe Default
Timer count set to Watch Dog Timer for POST. WARNING: Do not set to a value equal or shorter than normal POST time, otherwise system may never complete POST unless clearing BIOS settings. More than 2x normal POST time is suggested.		
Sends watch dog before booting OS	Disabled	Optimal Default, Failsafe Default
	Enabled	
Enabled - Robot set Watch Dog Timer (WDT) after POST completion, before BIOS transfer control to OS. WARNING: Before enabling this function, a program in OS must be in responsible for clearing WDT. Also, this function should be disabled if OS is going to update itself.		

Options Summary		
OS Timer (minute)	3	Optimal Default, Failsafe Default
Timer count set to Watch Dog Timer for OS loading.		
Delayed POST (PEI phase)	Disabled	Optimal Default, Failsafe Default
	Enabled	
Enabled - Robot holds BIOS from starting POST, right after power on. This allows BIOS POST to start with stable power or start after system is physically warmed-up. Note: Robot does this before 'Sends watch dog'.		
Delayed time (second)	10	Optimal Default, Failsafe Default
Period of time for Robot to hold BIOS from POST.		
Delayed POST (DXE phase)	Disabled	Optimal Default, Failsafe Default
	Enabled	
Enabled - Robot holds BIOS before POST completion. This allows BIOS POST to start with stable power or start after system is physically warmed-up. Note: Robot does this after 'Sends watch dog before BIOS POST'.		
Delayed time (second)	10	Optimal Default, Failsafe Default
Period of time for Robot to hold BIOS from POST.		
Reset system once	Disabled	Optimal Default, Failsafe Default
	Enabled	
Enabled - Robot resets system for one time on each boot. This will send a soft or hard reset to onboard devices, thus puts devices to more stable state.		
Soft or hard reset	Soft reset	Optimal Default, Failsafe Default
	Hard reset"	
Select reset type robot should send on each boot.		

3.4.12 Power Management

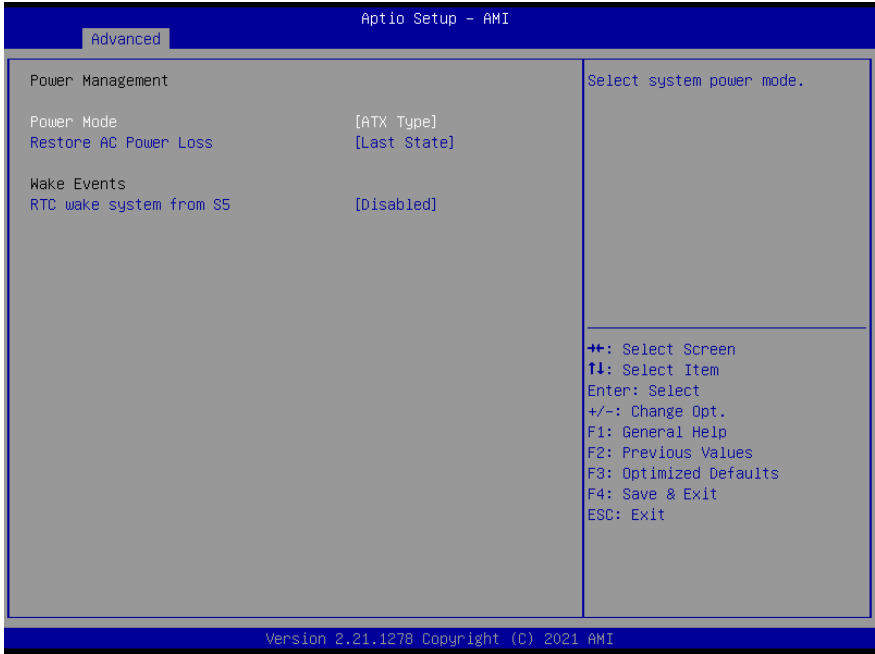

Options Summary		
Power Mode	ATX Type	Optimal Default, Failsafe Default
	AT Type	
Select power supply mode.		
Restore AC Power Loss	Last State	Optimal Default, Failsafe Default
	Always On	
	Always Off	
Select power state when power is re-applied after a power failure.		
Soft-Off (S5) Wake On RTC	Disable	Optimal Default, Failsafe Default
	By Date	
	By Weekday	
	Bypass	
By Date: System will wake on the with hr::min::sec specified. By Weekday: System will wake on the enabled weekday with hr::min::sec specified. Bypass: BIOS will not control RTC wake function.		

3.4.13 GPIO Port Configuration

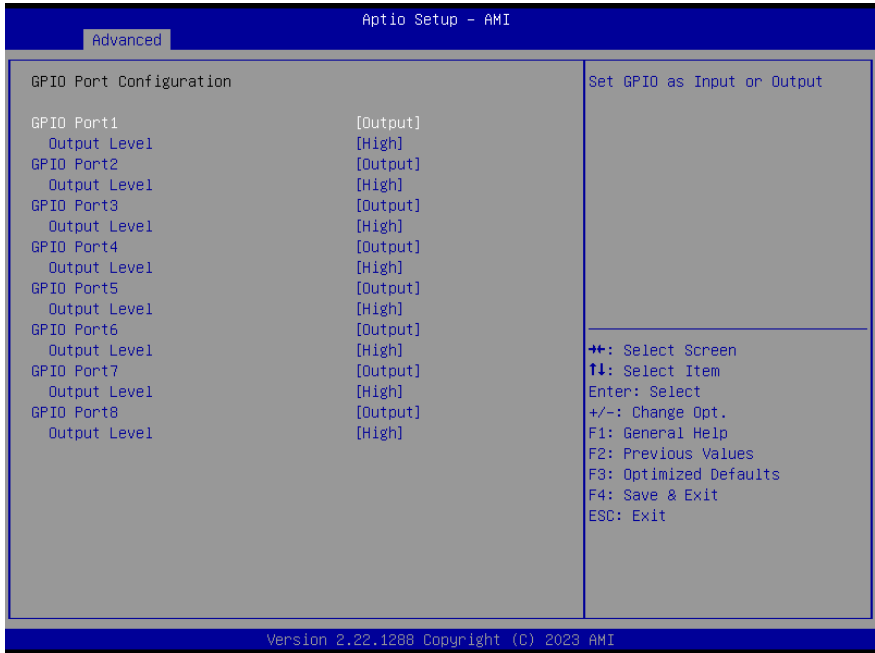

Options Summary		
GPIO Port*	Output	
	Input	
Set GPIO as Input or Output.		
Output Level	High	
	Low	
Set output level when GPIO pin is Output.		

3.4.14 AAEON Smart Boost

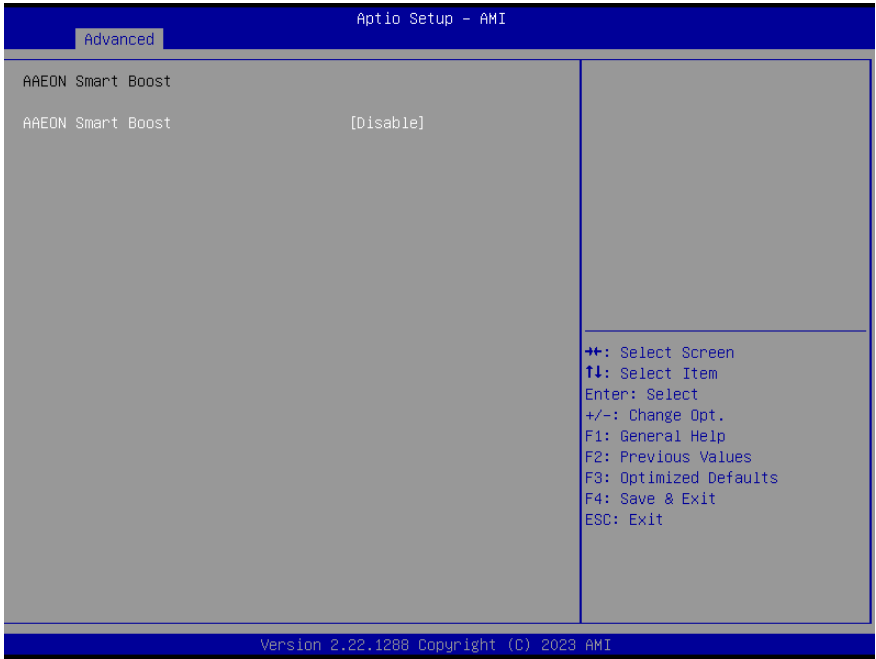

Options Summary		
AAEON Smart Boost	Smart Boost	
	Maximum Performance	
	Good Stability	
	Disabled	Optimal Default, Failsafe Default

3.5 Setup Submenu: Chipset



3.5.1 System Agent (SA) Configuration

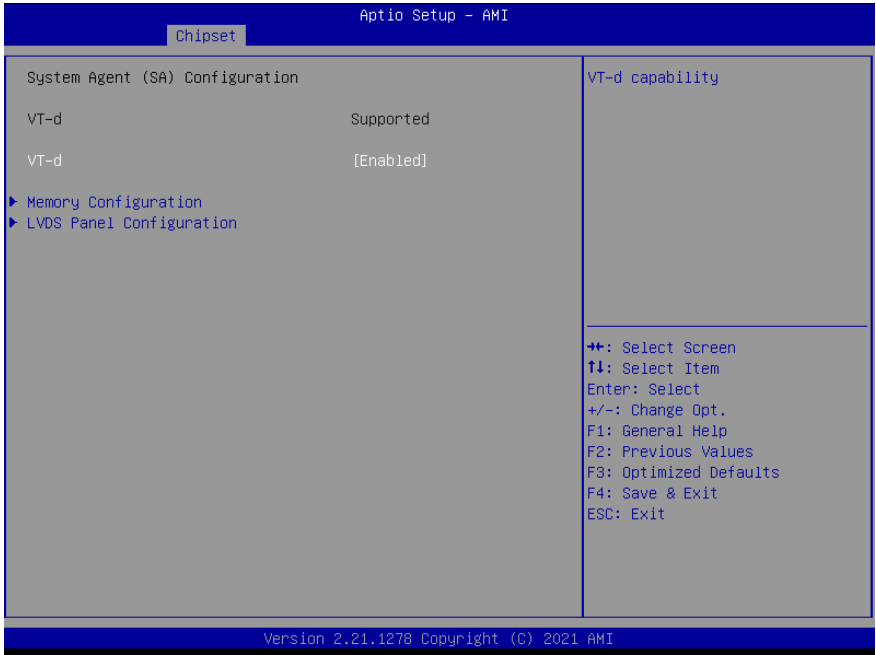

Options Summary		
VT-d	Disabled	Optimal Default, Failsafe Default
	Enabled	
VT-d capability.		

3.5.2 Memory Configuration

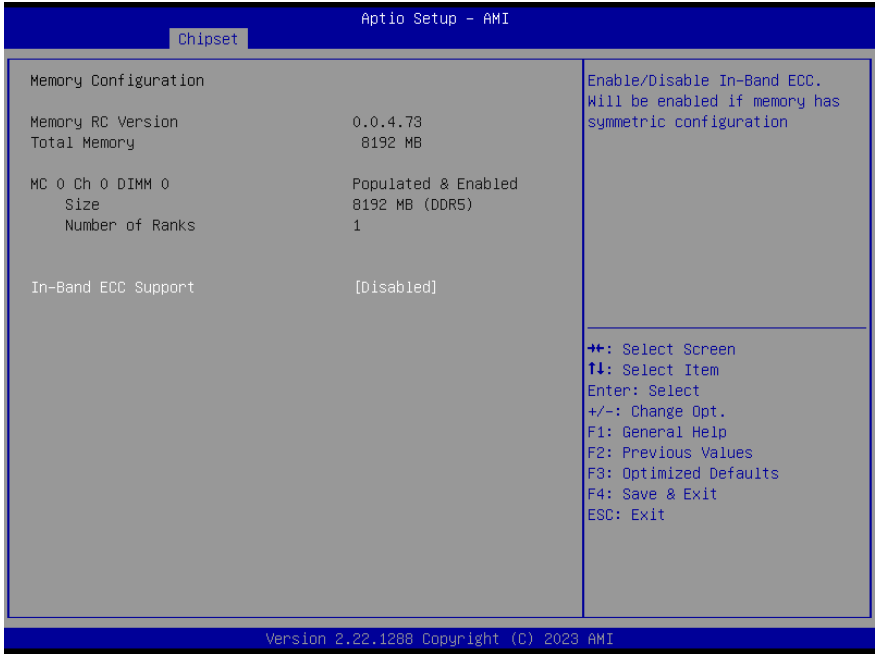

Options Summary		
In-Band ECC Support	Disabled	Optimal Default, Failsafe Default
	Enabled	
Enable/Disable In-Band ECC. Will be enabled if memory has symmetric configuration.		

3.5.3 LVDS Panel Configuration



Options Summary		
LVDS	Disabled	
	Enabled	
Enable/Disabled this panel.		
LVDS Panel Type	640x480,18bit,60Hz	
	800x480,18bit,60Hz	
	800x600,18bit,60Hz	
	1024x600,18bit,60Hz	
	1024x768,18bit,60Hz	
	1024x768,24bit,60Hz	Optimal Default, Failsafe Default
	1280x768,24bit,60Hz	
	1280x1024,48bit,60Hz	
	1366x768,24bit,60Hz	
	1440x900,48bit,60Hz	
	1600x1200,48bit,60Hz	
1920x1080,48bit,60Hz		

Options Summary		
LVDS Panel Type Cont.	1920x1200,48bit,60Hz	
Select LCD panel used by Internal Graphics Device by selecting the appropriate setup item.		
Color Depth	18-bit	Optimal Default, Failsafe Default
	24-bit	
	36-bit	
	48-bit	
Select panel type.		
Backlight Mode	BIOS & Application	
	Windows Slider	Optimal Default, Failsafe Default
Select backlight control signal type.		

3.5.4 PCH-IO Configuration



Options Summary		
HD Audio	Disabled	
	Enabled	Optimal Default, Failsafe Default
Control Detection of the HD-Audio device. Disable = HAD will be unconditionally disabled Enable = HAD will be unconditionally enabled.		
Full-Mini Card Slot Function (CN27)	SATA	Optimal Default, Failsafe Default
	PCIe	
Select function enabled for Full-Mini Card (CN27) slot.		

3.6 Setup Submenu: Security

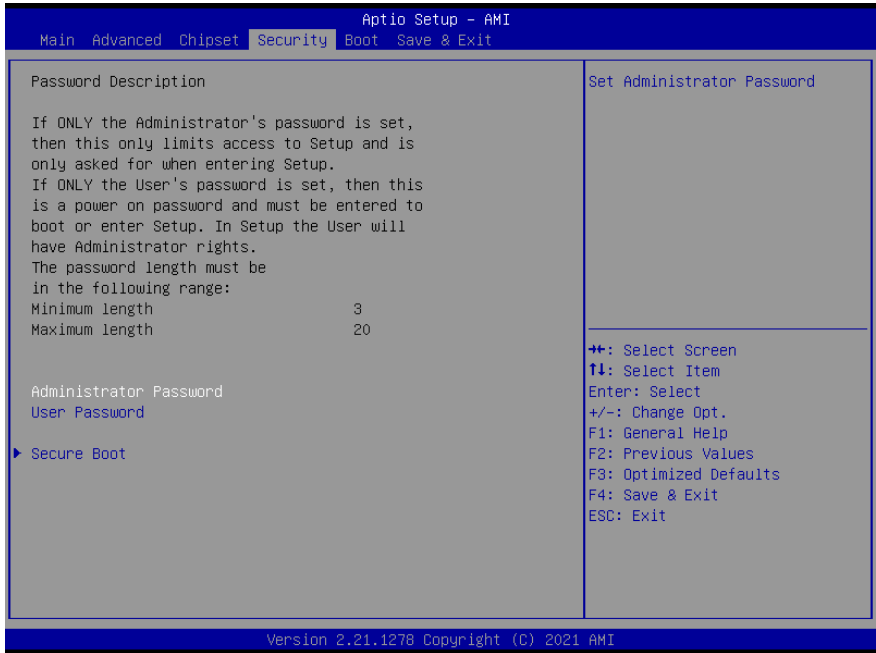

Change User/Supervisor Password

You can install a Supervisor password, and if you install a supervisor password, you can then install a user password. A user password does not provide access to many of the features in the Setup utility.

If you highlight these items and press Enter, a dialog box appears which lets you enter a password. You can enter no more than six letters or numbers. Press Enter after you have typed in the password. A second dialog box asks you to retype the password for confirmation. Press Enter after you have retyped it correctly. The password is required at boot time, or when the user enters the Setup utility.

Removing the Password

Highlight this item and type in the current password. At the next dialog box press Enter to disable password protection.

3.6.1 Secure Boot



Options Summary		
Secure Boot	Disabled	Optimal Default, Failsafe Default
	Enabled	
Secure Boot feature is Active if Secure Boot is Enabled, Platform Key (PK) is enrolled and the System is in User mode. The mode change requires platform reset.		
Secure Boot Mode	Custom	Optimal Default, Failsafe Default
	Standard	
Secure Boot mode options: Standard or Custom. In Custom mode, Secure Boot Policy variables can be configured by a physically present user without full authentication.		
Restore Factory Keys		
Force System to User Mode. Install factory default Secure Boot key databases.		
Reset to Setup Mode		
Delete all Secure Boot key databases from NVRAM.		

Options Summary	
Remove 'UEFI CA' from DB	
Device Guard ready system must not list 'Microsoft UEFI CA' Certificate in Authorized Signature database (db).	
Restore DB defaults	
Restore DB variable to factory defaults.	
Platform Key (PK)	Details
	Export
	Update
	Delete
Key Exchange Keys	Details
	Export
	Update
	Append
	Delete
Authorized Signatures	Details
	Export
	Update
	Append
	Delete
Forbidden Signatures	Details
	Export
	Update
	Append
	Delete
Authorized TimeStamps	Update
	Append
OsRecovery Signatures	Update
	Append
Enroll Factory Defaults or load certificates from a file:	
1.Public Key Certificate:	
a) EFI_SIGNATURE_LIST	
b) EFI_CERT_X509 (DER)	
c) EFI_CERT_RSA2048 (bin)	
d) EFI_CERT_SHAXXX	
2.Authenticated UEFI Variable	
3.EFI PE/COFF Image (SHA256)	
Key Source: Factory, External, Mixed	

3.7 Setup Submenu: Boot

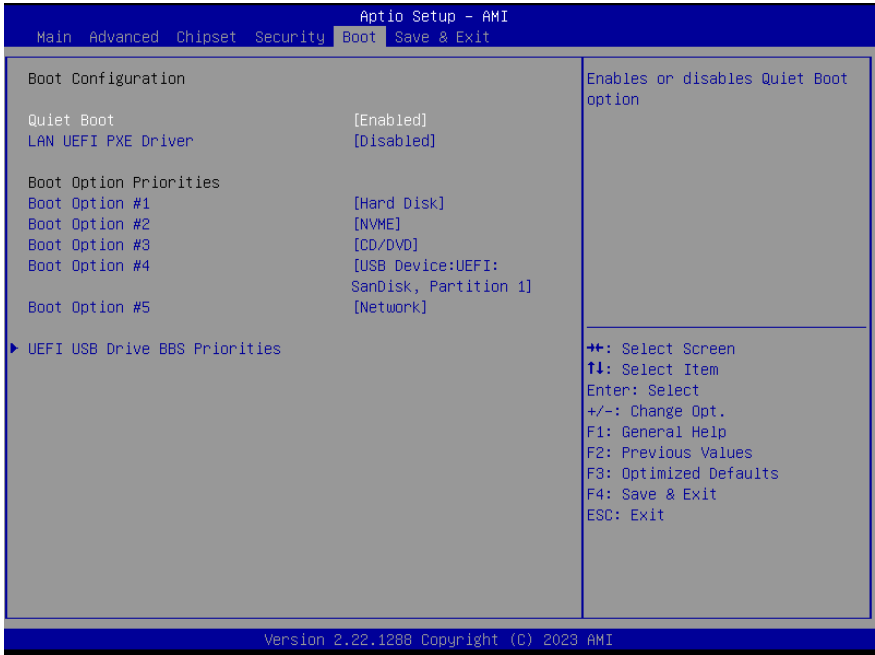

Options Summary		
Quiet Boot	Disabled	
	Enabled	Optimal Default, Failsafe Default
Enable or Disable Quiet Boot option.		
UEFI PXE Support	Disabled	Optimal Default, Failsafe Default
	Enabled	
Enable/Disable UEFI Network Stack.		
FIXED BOOT ORDER Priorities		
Sets the system boot order.		

3.7.1 BBS Priorities

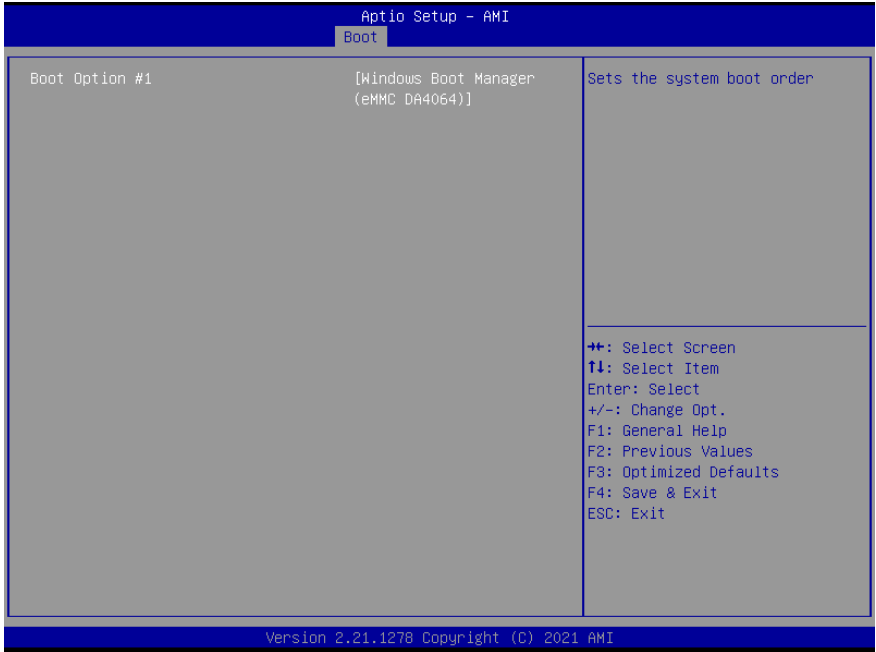

3.8 Setup Submenu: Save & Exit



Options Summary	
Save Changes and Reset	Reset the system after saving the changes.
Discard Changes and Exit	Exit system setup without saving any changes.
Restore Defaults	Restore/Load Default values for all the setup options.

Chapter 4

Driver Installation

4.1 Driver Download/Installation

Drivers for the GENE-ADN6 can be downloaded from the product page on the AAEON website by following this link:

<https://www.aaeon.com/en/p/subcompact-boards-gene-adn6>

Download the driver(s) you need and follow the steps below to install them.

Chipset Driver

1. Open the folder where you unzipped the **Chipset Drivers**.
2. Run the **SetupChipset.exe** file in the folder.
3. Follow the instructions.
4. Drivers will be installed automatically.

Graphics Driver

1. Open the **Graphics Driver** folder
2. Run the **Installer.exe** file in the folder.
3. Follow the instructions.
4. Drivers will be installed automatically.
5. Refer to the ReadMe.txt for any assistance.

LAN Drivers

1. Open the **LAN** folder
2. Open the **.exe** file in the folder
3. Follow the instructions
4. Drivers will be installed automatically

Install Intel Smart Sound Driver

1. Open the **Intel Smart Sound** folder
2. Navigate the folder as follows: **Production > Driver**, then follow the below instructions to install the BUS Driver (IntcAudioBus.inf) and OED Driver (IntcOED.inf).

Install BUS driver (IntcAudioBus.inf)

- a. Press Right Key -> Install

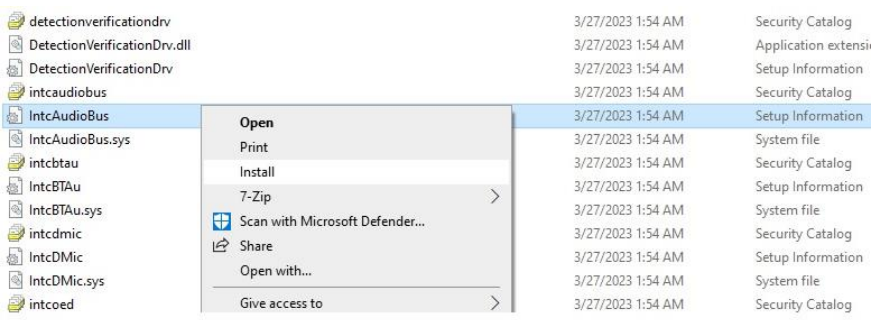

Install OED driver (IntcOED.inf)

- b. Press Right Key -> Install

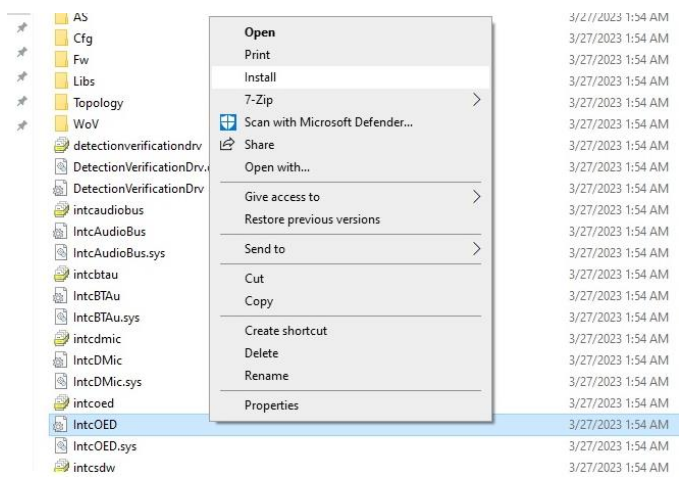

Install Windows Audio Driver

1. Open the **Windows Audio** folder followed by **Setup.exe**
2. Follow the instructions
3. Drivers will be installed automatically

Install Peripheral Driver

1. Open the **Peripheral Driver** folder
2. Open the **SetupSerialIO.exe** file
3. Follow the instructions
4. Drivers will be installed automatically

Install SIO Driver

1. Open the **SIO** folder and select your OS
2. Open the **FintekSerial.exe** file
3. Follow the instructions
4. Drivers will be installed automatically

Install Intel CSME Driver

1. Open the **Intel CSME** folder and select your OS
2. Open the **SetupME.exe** file
3. Follow the instructions
4. Drivers will be installed automatically

Install Camera Driver

1. Open the **Camera Driver** folder
2. Follow the instructions provided in the **Documentation** subfolder to manually install drivers

Appendix A

I/O Information

A.1 I/O Address Map

3.5" Subcompact Board

GENE-ADnG

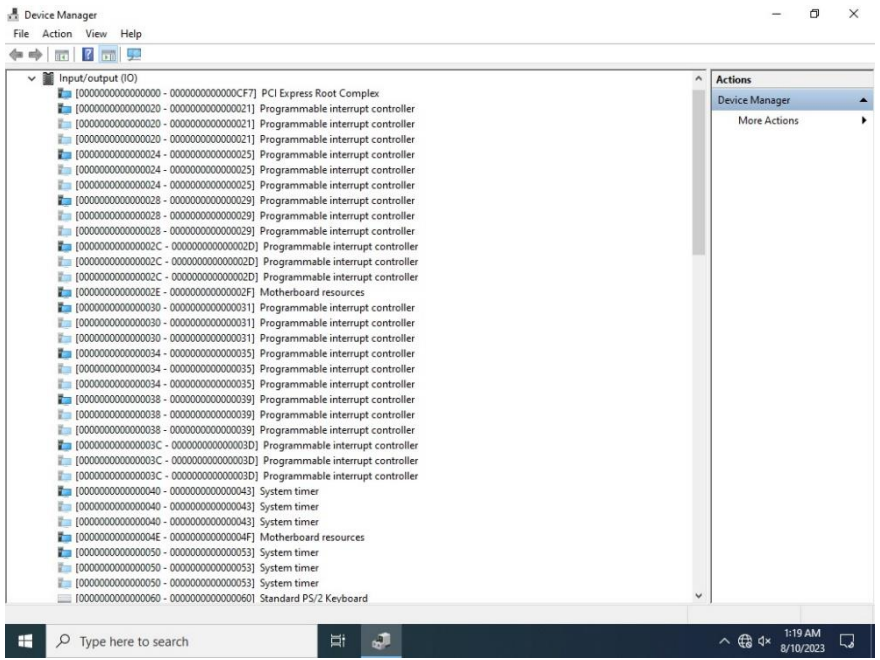

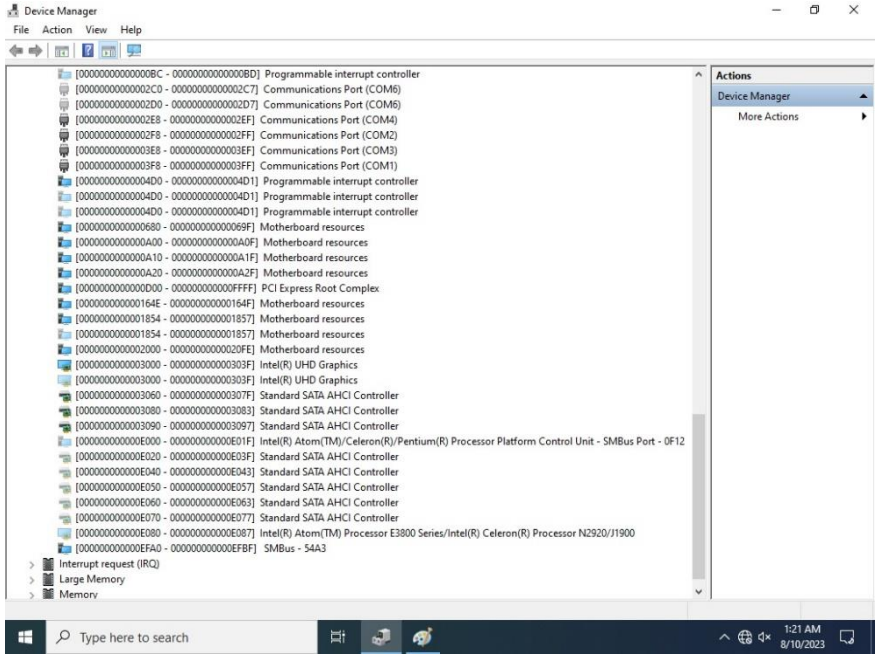
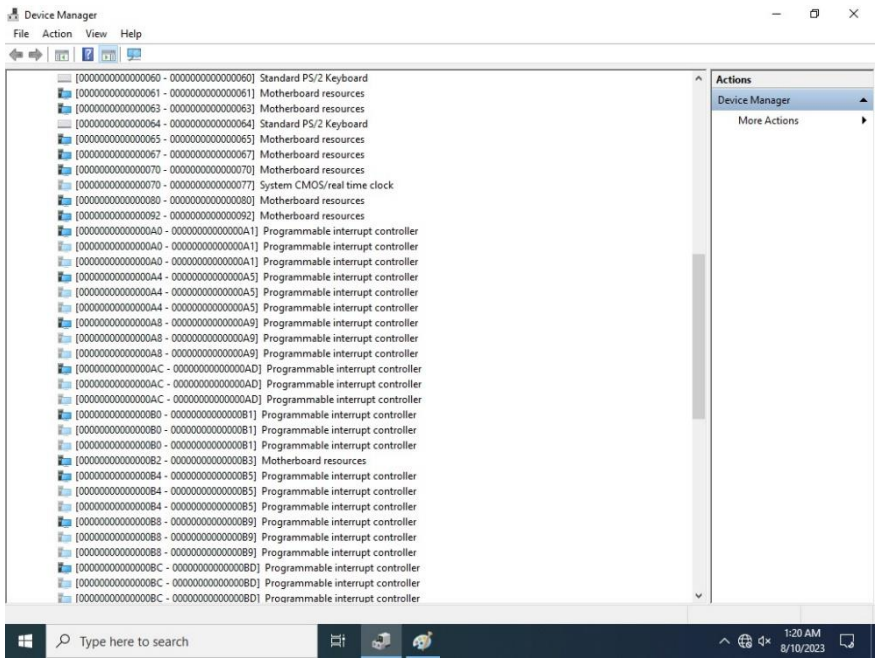

A.2 Memory Address Map

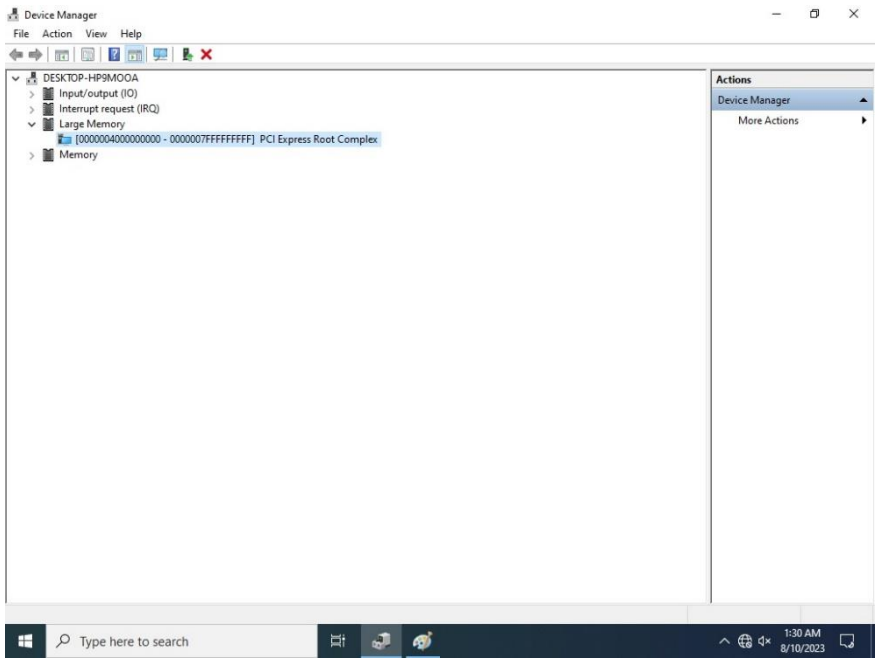

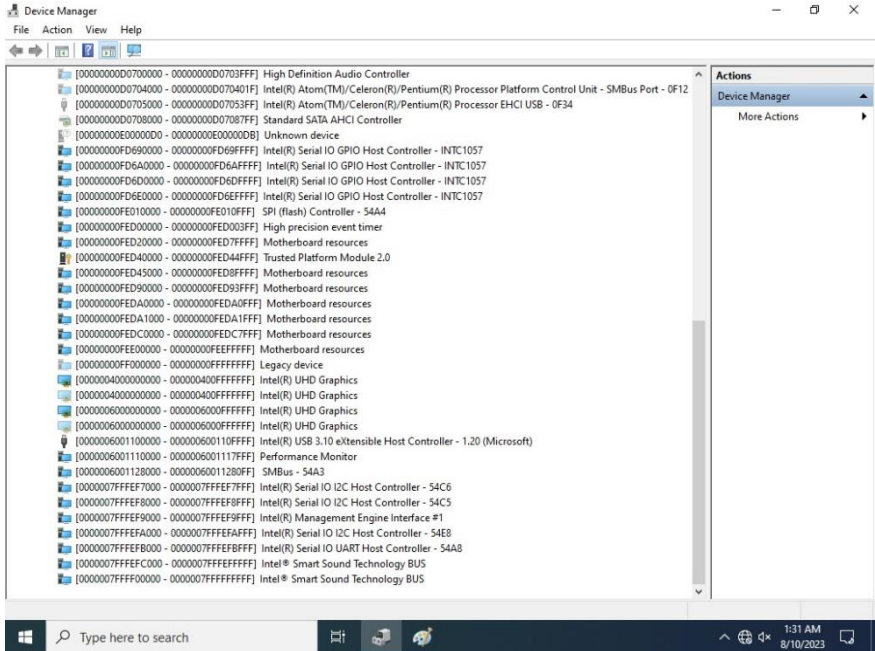
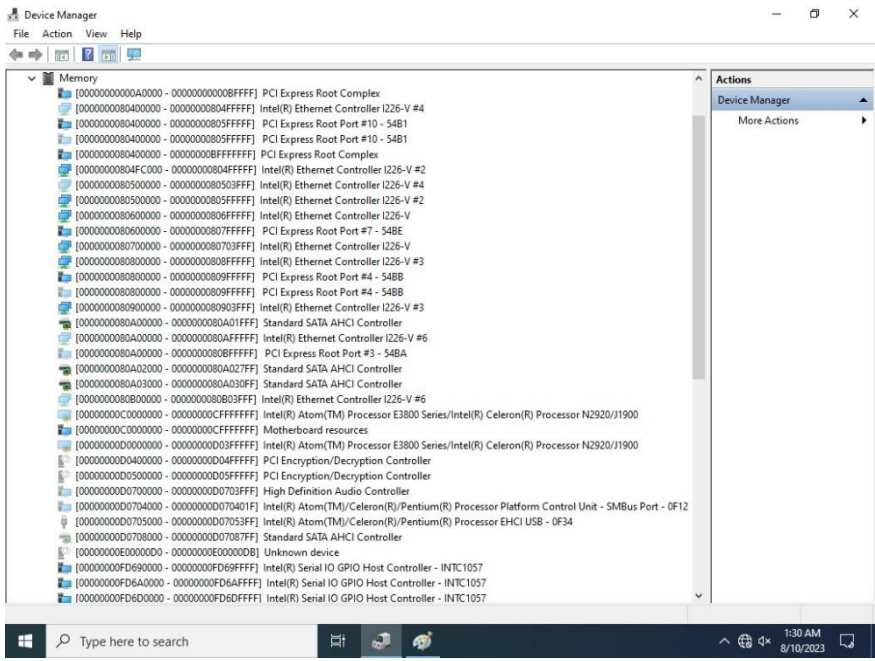

A.3 IRQ Mapping Chart

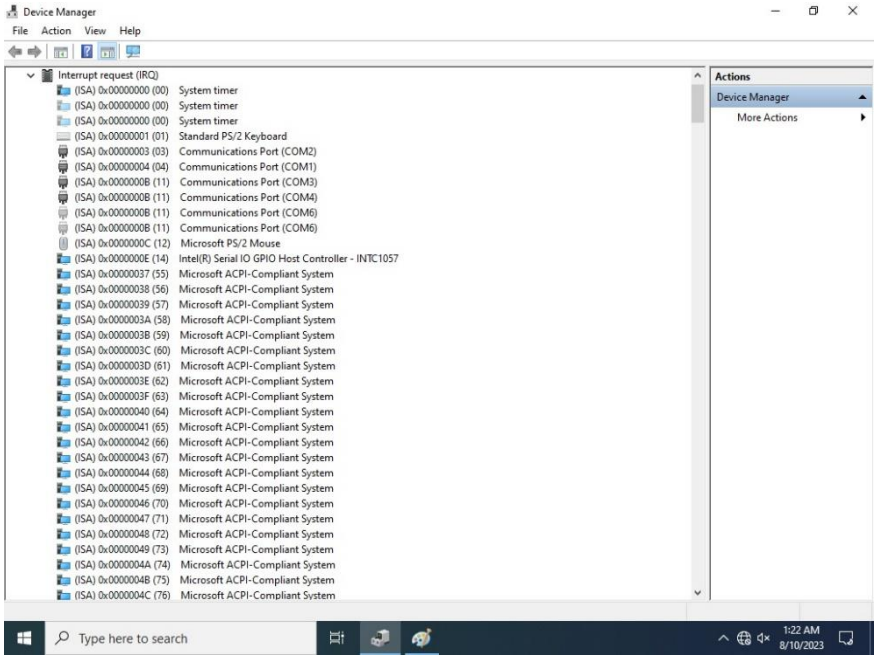

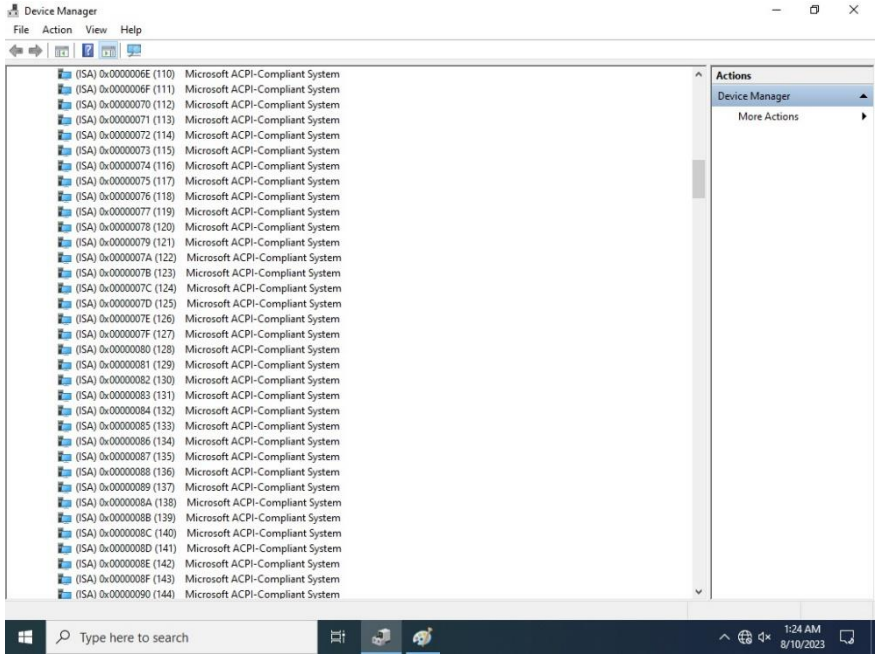
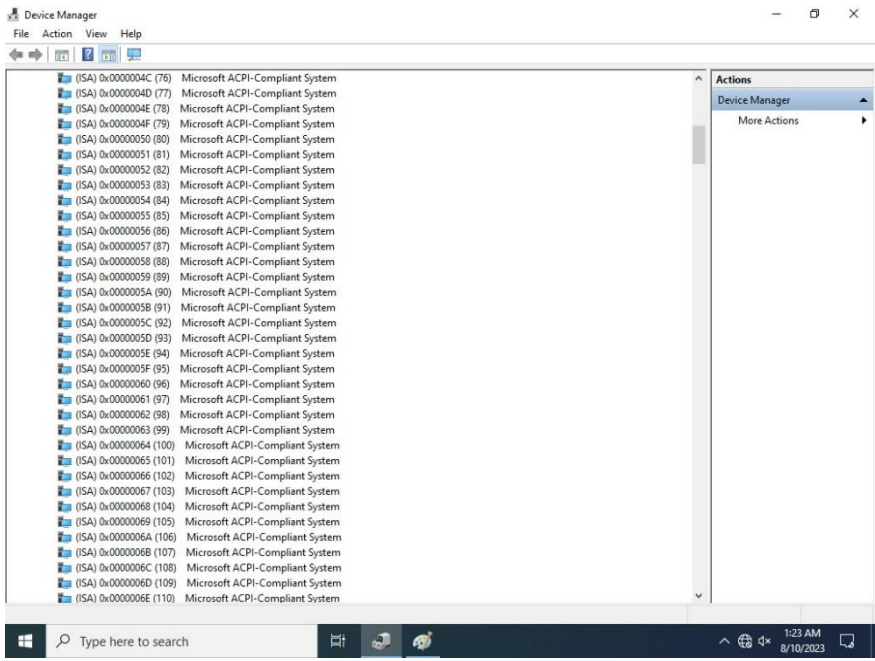

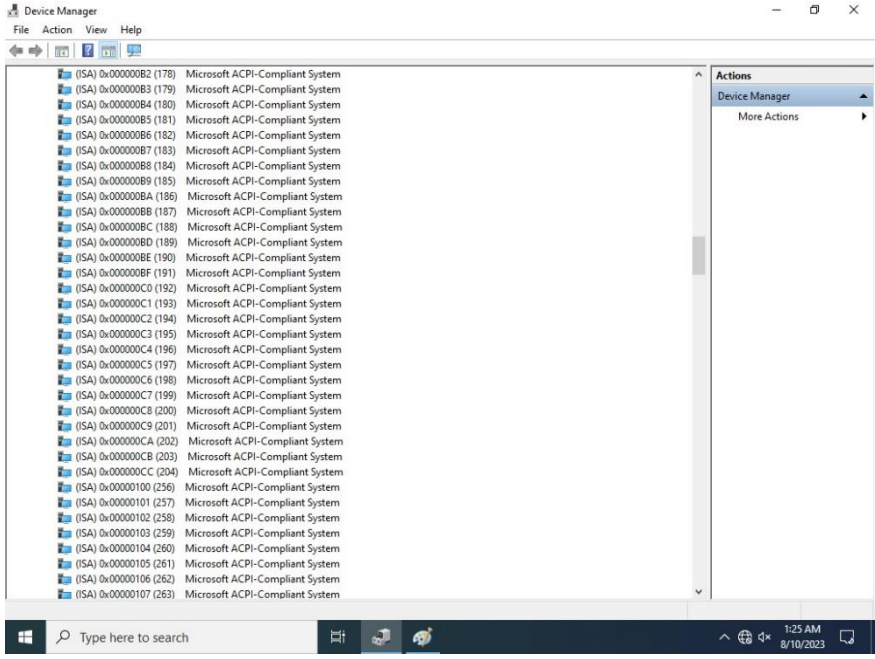
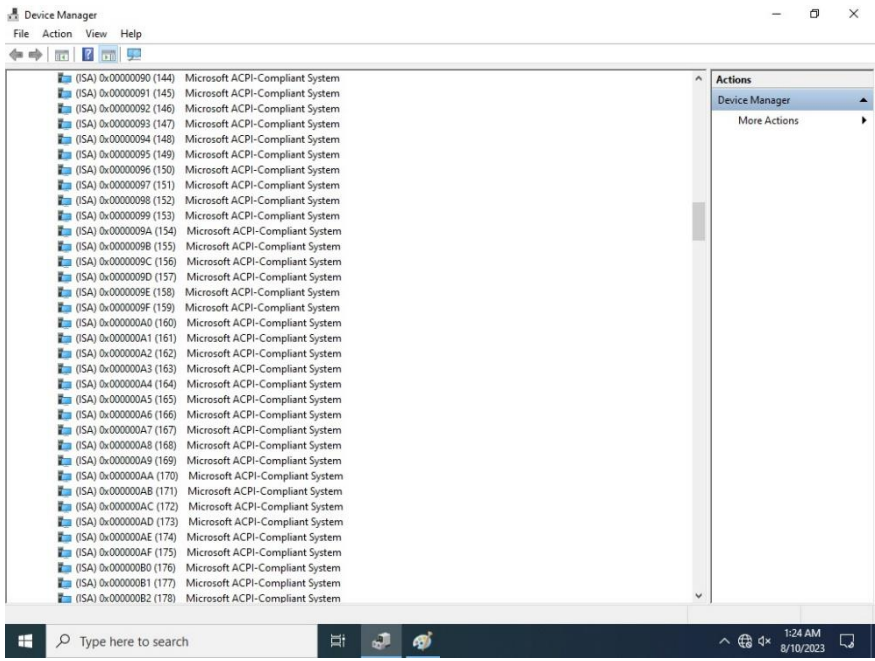

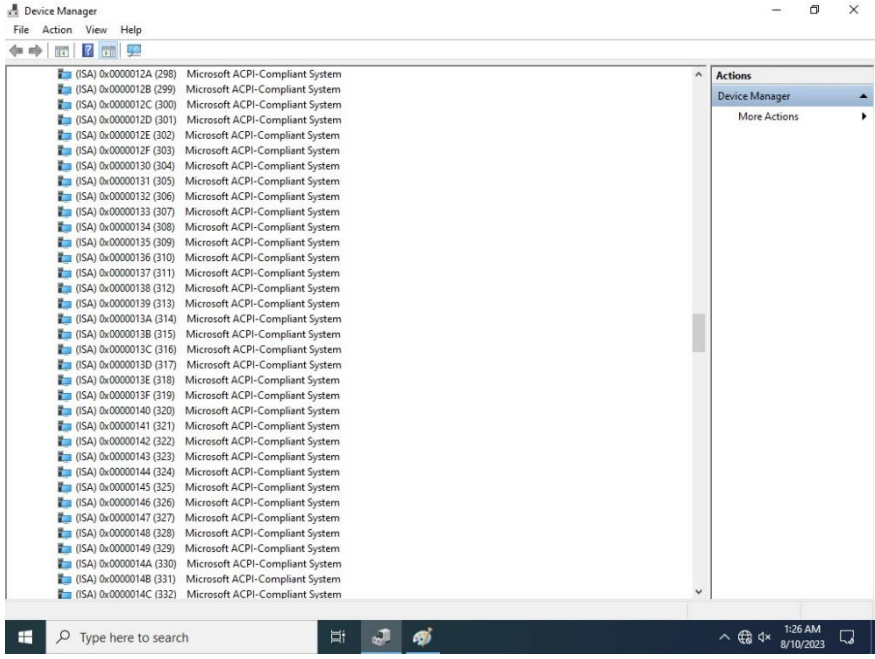
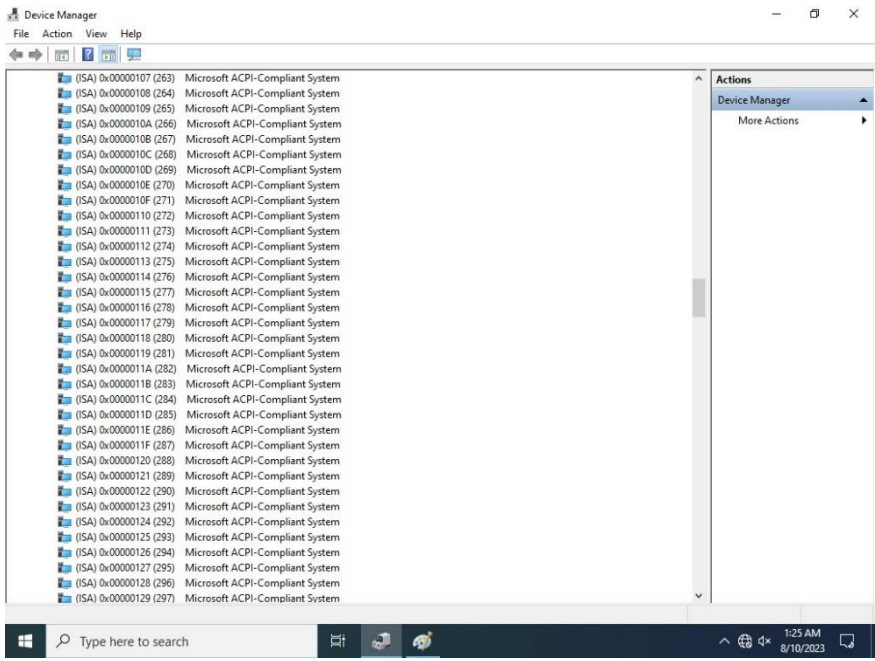

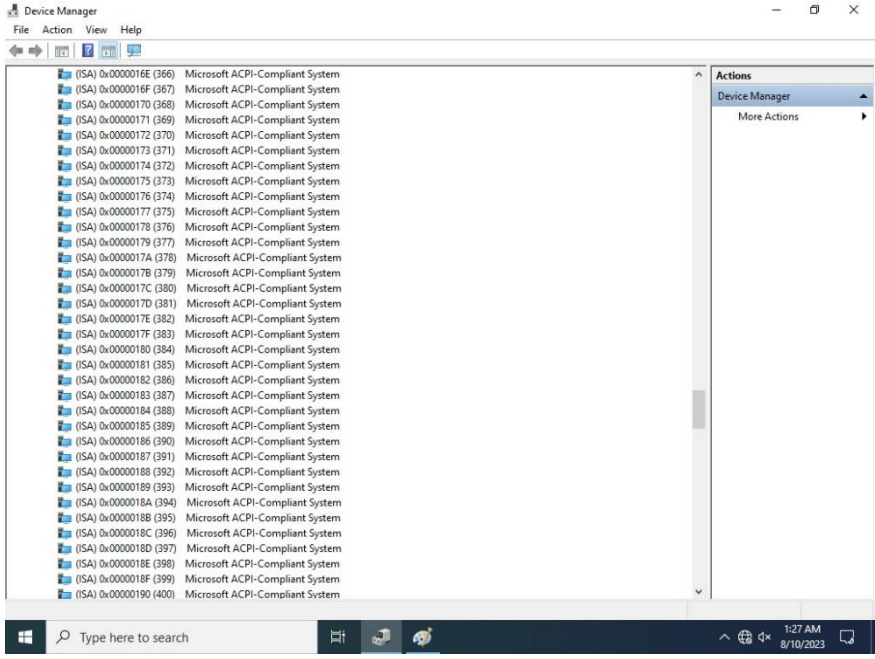
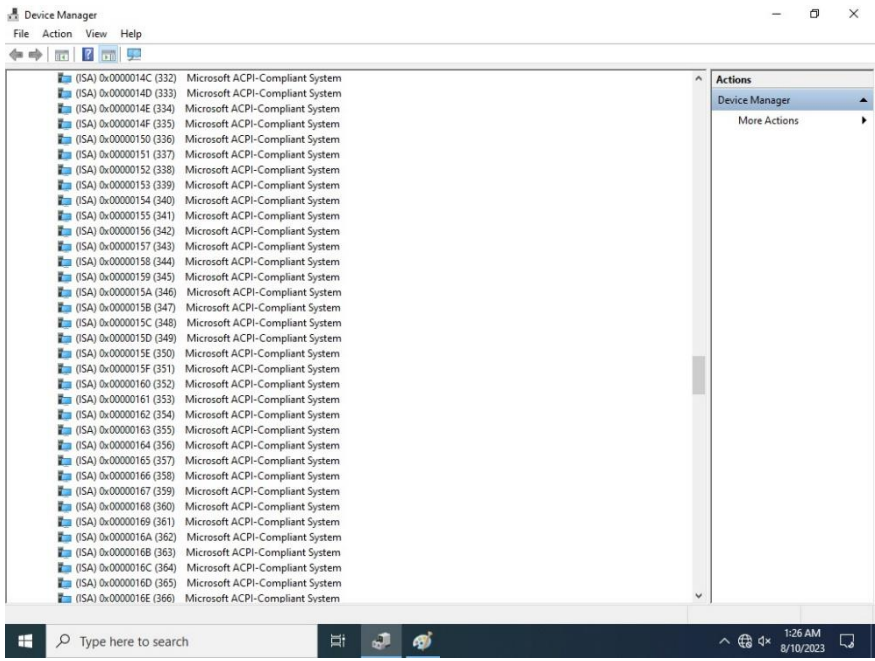

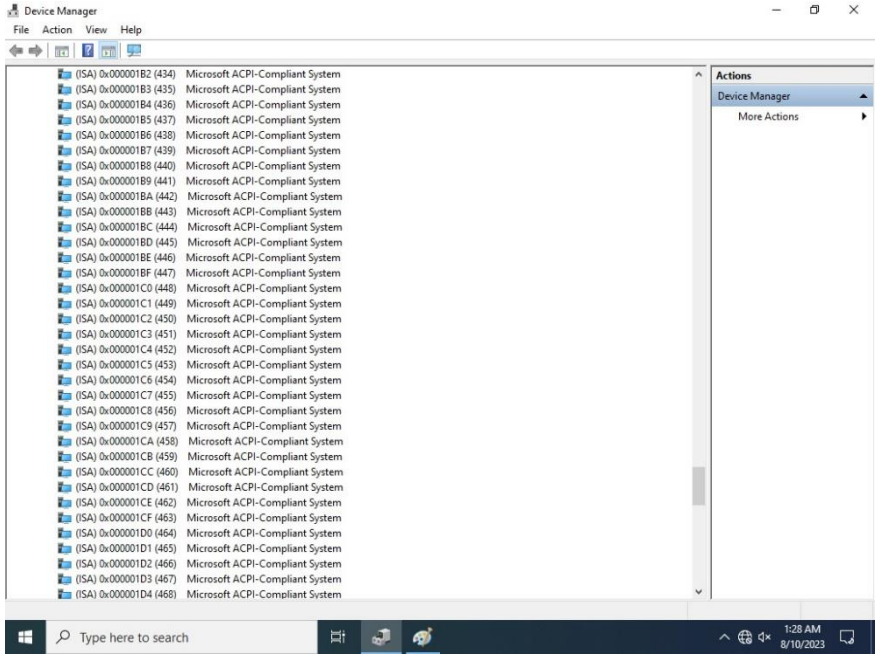
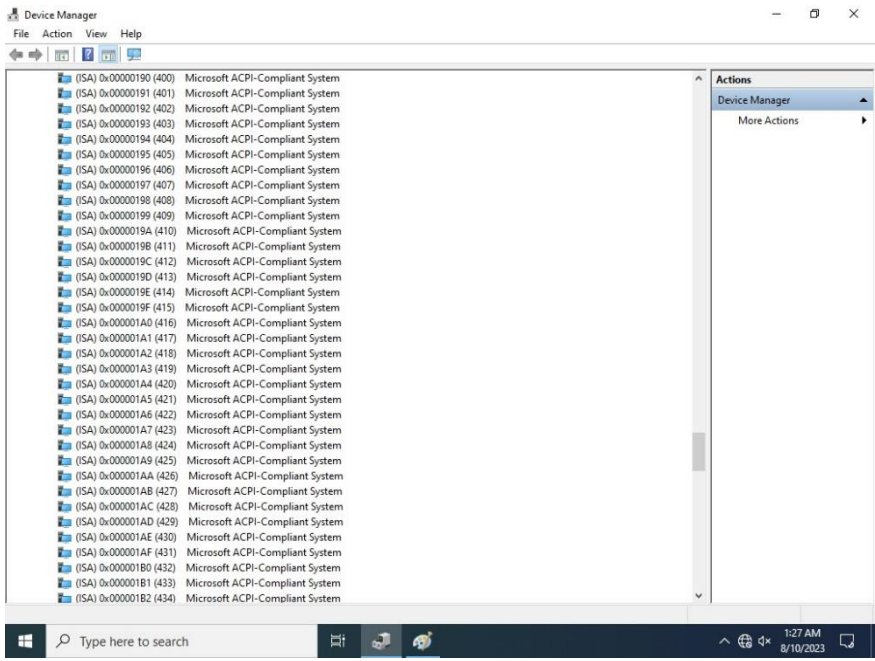

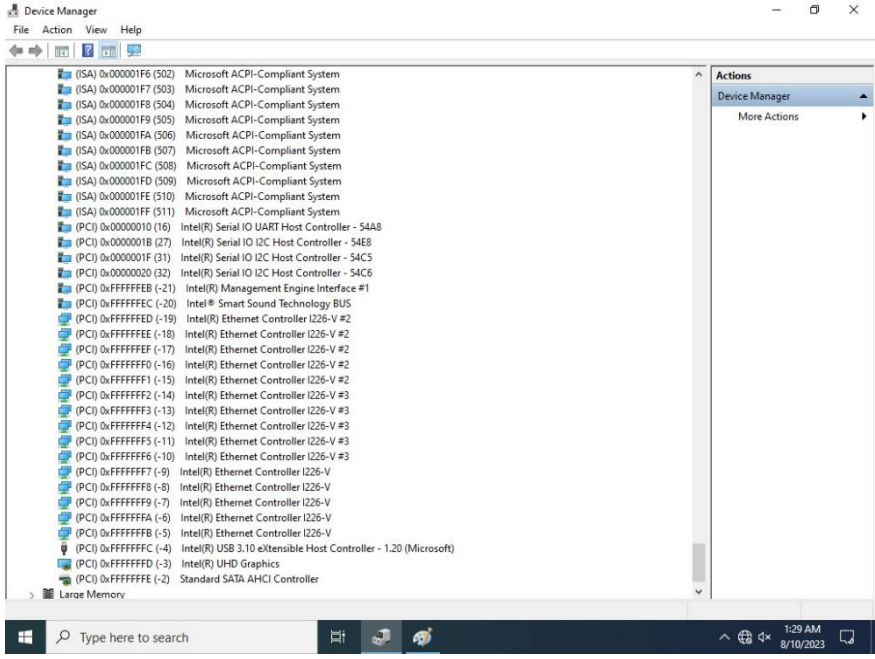
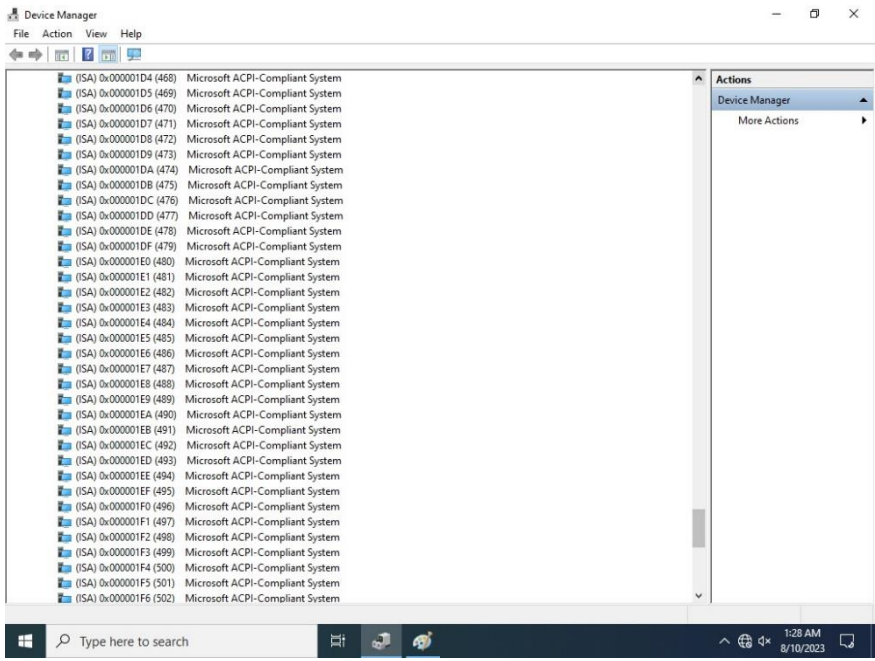

Appendix B

Mating Connectors and Cables

B.1 Mating Connectors and Cables

Label	Function	Vendor	Model No	Cable P/N
CN1	SATA Power	JST	PHR-2	1702150155
CN2	Front Panel	JST	SHR-10V-S-B	170X000287
CN3	Port 80 Debug Port	JST	SHR-10V-S-B	1703100133
CN5	SATA	Molex	887505318	N/A
CN9	Power	N/A	N/A	170204010R
CN11	Audio with detect	Aces	50247-012H0H0-001	170X000156
CN13	External +5VSB Power Input and PS_ON#	JST	XHP-3	170220020B
CN18	GPIO	MOLEX	51110-1050	N/A
CN22	LAN1 LED	JST	SHR-04V-S-B	170X000634
CN23	LAN3 LED	JST	SHR-04V-S-B	170X000634
CN24	LAN2 LED	JST	SHR-04V-S-B	170X000634
CN28	LVDS	Hirose	DF13-30DS-1.25C	170430030Y
CN33	CPU FAN	Molex	51021-0400	N/A
CN34	LVDS Inverter	JST	SHR-06V-S-B	170X000152
CN39	External RTC	Molex	51021-0200	175011301K
CN42	I2C/SMBUS	JST	SHR-05V-S-B	170X000743
CN44	COM Port1	Molex	51021-0900	1701090150
CN45	COM Port2	Molex	51021-0900	1701090150
CN46	COM Port3	Molex	51021-0900	1701090150
CN47	COM Port4	Molex	51021-0900	1701090150
CN48	USB 2.0 Port3	Molex	51021-0500	1700050207
CN49	USB 2.0 Port4	Molex	51021-0500	1700050207
CN50	USB 2.0 Port5	Molex	51021-0500	1700050207
CN51	USB 2.0 Port6	Molex	51021-0500	1700050207