

GCS-1500i

Green Communication System

Intel® Core™i7/i5 rPGA988 Processor

2.5" SATA Hard Disk Drive Bay

4 Gigabit Ethernet Ports/

9 COM / 8 USB2.0

VGA x 1, DVI-I x 1

Copyright Notice

This document is copyrighted, 2011. All rights are reserved. The original manufacturer reserves the right to make improvements to the products described in this manual at any time without notice.

No part of this manual may be reproduced, copied, translated, or transmitted in any form or by any means without the prior written permission of the original manufacturer. Information provided in this manual is intended to be accurate and reliable. However, the original manufacturer assumes no responsibility for its use, or for any infringements upon the rights of third parties that may result from its use.

The material in this document is for product information only and is subject to change without notice. While reasonable efforts have been made in the preparation of this document to assure its accuracy, AAEON assumes no liabilities resulting from errors or omissions in this document, or from the use of the information contained herein.

AAEON reserves the right to make changes in the product design without notice to its users.

Acknowledgments

All other products' name or trademarks are properties of their respective owners.

- Award is a trademark of Award Software International, Inc.
- CompactFlash™ is a trademark of the Compact Flash Association.
- Microsoft Windows® is a registered trademark of Microsoft Corp.
- Intel®, Core™ are trademarks of Intel Corporation.
- PC/AT, PS/2, and VGA are trademarks of International Business Machines Corporation.

All other product names or trademarks are properties of their respective owners.

Packing List

Before you begin operating your PC, please make sure that the following materials are enclosed:

- GCS-1500i Bare Bone
- Phoenix Connector
- Cushion For HDD
- Ear Bracket Module
- DVD-ROM for manual (in PDF format) and drivers

If any of these items should be missing or damaged, please contact your distributor or sales representative immediately.

Safety & Warranty

1. Read these safety instructions carefully.
2. Keep this user's manual for later reference.
3. Disconnect this equipment from any AC outlet before cleaning. Do not use liquid or spray detergents for cleaning. Use a damp cloth.
4. For pluggable equipment, the power outlet must be installed near the equipment and must be easily accessible.
5. Keep this equipment away from humidity.
6. Put this equipment on a firm surface during installation. Dropping it or letting it fall could cause damage.
7. The openings on the enclosure are for air convection. Protect the equipment from overheating. **DO NOT COVER THE OPENINGS.**
8. Make sure the voltage of the power source is correct before connecting the equipment to the power outlet.
9. Position the power cord so that people cannot step on it. Do not place anything over the power cord.
10. All cautions and warnings on the equipment should be noted.
11. If the equipment is not used for a long time, disconnect it from the power source to avoid damage by transient over-voltage.
12. Never pour any liquid into an opening. This could cause fire or electrical shock.
13. Never open the equipment. For safety reasons, only qualified service personnel should open the equipment.
14. If any of the following situations arises, get the equipment checked by service personnel:
 - a. The power cord or plug is damaged.
 - b. Liquid has penetrated into the equipment.
 - c. The equipment has been exposed to moisture.

- d. The equipment does not work well, or you cannot get it to work according to the user's manual.
 - e. The equipment has been dropped and damaged.
 - f. The equipment has obvious signs of breakage.
15. DO NOT LEAVE THIS EQUIPMENT IN AN ENVIRONMENT WHERE THE STORAGE TEMPERATURE IS BELOW -20°C (-4°F) OR ABOVE 65°C (149°F). IT MAY DAMAGE THE EQUIPMENT.

FCC

Warning!



This device complies with Part 15 FCC Rules. Operation is subject to the following two conditions: (1) this device may not cause harmful interference, and (2) this device must accept any interference received including interference that may cause undesired operation.

Caution:

There is a danger of explosion if the battery is incorrectly replaced. Replace only with the same or equivalent type recommended by the manufacturer. Dispose of used batteries according to the manufacturer's instructions and your local government's recycling or disposal directives.

ENERGY STAR



This Product has been certified by ENERGY STAR®

The Regulation of ENERGY STAR®: ENERGY STAR® Requirements for Computer Version 5.2.

The Test Standard of ENERGY STAR®: IEC/EN 62301, ENERGY STAR® Program Requirements for Computer Version

ENERGY STAR® Compliance: Power Management features (Basic)

Using power-saving states

The system provides the two power-saving states: Sleep and Hibernation.

When Sleep is initiated, the power lights blink and the screen clears. Your working task is saved to memory. Exiting Sleep is faster than exiting Hibernation. If the system is in the Sleep state for an extra period or if the battery reaches a critical battery level while in the Sleep state, the system initiates Hibernation.

When Hibernation is initiated, your work is saved to a hibernation file on the hard drive and the system turns off.

Initiating and exiting Sleep

The system set the Sleep mode after 30 minutes of inactivity when running on external power. You can change to none Sleep mode if the system needs to be active at all time. The default power management settings have been selected for compliance with ENERGY STAR[®], and are recommended by the ENERGY STAR[®] program for optimal energy savings.

Using power plans

You can choose your own power plan which is a collection of system settings that manages how the system uses power. Power plans can help you conserve power or maximize performance.

Below Table for China RoHS Requirements

产品中有毒有害物质或元素名称及含量

AAEON Boxer/ Industrial System

部件名称	有毒有害物质或元素					
	铅 (Pb)	汞 (Hg)	镉 (Cd)	六价铬 (Cr(VI))	多溴联苯 (PBB)	多溴二苯醚 (PBDE)
印刷电路板 及其电子组件	×	○	○	○	○	○
外部信号 连接器及线材	×	○	○	○	○	○
外壳	×	○	○	○	○	○
中央处理器 与内存	×	○	○	○	○	○
硬盘	×	○	○	○	○	○
电源	×	○	○	○	○	○

O: 表示该有毒有害物质在该部件所有均质材料中的含量均在
SJ/T 11363-2006 标准规定的限量要求以下。

X: 表示该有毒有害物质至少在该部件的某一均质材料中的含量超出
SJ/T 11363-2006 标准规定的限量要求。

备注:

一、此产品所标示之环保使用期限，系指在一般正常使用状况下。

二、上述部件物质中央处理器、内存、硬盘、电源为选购品。

Contents

Chapter 1 General Information

1.1 Introduction	1-2
1.2 Features	1-3
1.3 Specifications	1-4
1.4 General System Information	1-6

Chapter 2 Hardware Installation

2.1 Location of Jumpers and Connectors	2-2
2.2 Mechanical Drawing	2-7
2.3 Setting Jumpers	2-8
2.4 Pin Definition of IMBI-QM57.....	2-9
2.5 Pin Definition of PER-T167	2-18
2.6 CPU And RAM Module Instalation.....	2-23

Chapter 3 AMI BIOS Setup

3.1 System Test and Initialization.	3-2
3.2 AMI BIOS Setup.....	3-3

Chapter 4 Driver Installation

4.1 Installation	4-3
------------------------	-----

Appendix A Programming The Watchdog Timer

A.1 Programming	A-2
-----------------------	-----

A.2 ITE8781 Watchdog Timer Initial ProgramA-6

Appendix B I/O Information

B.1 I/O Address MapB-2
B.2 1st MB Memory Address MapB-4
B.3 IRQ Mapping ChartB-5
B.4 DMA Channel Assignments..... B-5

Appendix C AHCI Settings

C.1 Setting AHCI C-2

Chapter

1

**General
Information**

1.1 Introduction

GCS-1500i adopts the Intel® Core™ i7/i5 rPGA988 Processor. The TDP is 35W Max. The chipset is equipped with Intel® QM57. Moreover, the system memory features two DDR3 800/1066 MHz SODIMM socket up to 8 GB. It deploys four LAN ports that consist of 10/100/1000Base-TX Ethernet LAN RJ-45 ports. GCS-1500i condensed appearance features desktop and rackmount form factor that fits nicely into a space-limited environment.

This compact GCS-1500i equipped with one internal 2.5” Hard Disk Drive with SATA 3.0Gb/s interface. In addition, it features eight isolated COM ports and eight USB2.0 ports for flexible expansions.

1.2 Features

- 1.5U 19" Rackmount, Fanless Design
- Intel® Core™ i7/i5 rPGA988 Processor, TDP 35W Max.
- Intel® QM57
- Dual-Channel DDR3 800/1066 Memory (Up To 8 GB)
- 10/100/1000Base-TX Ethernet x 4
- VGA x 1, DVI-I x 1
- Serial Port With Isolation x 8, USB 2.0 x 8, 8-bit Digital I/O
- Internal 2.5" Disk Drive Bay x 1
- Wide Range 10~30V DC-In

1.3 Specifications

● CPU		Intel® Core™ i7/i5 rPGA988, max. TDP 35W
● Chipset		Intel® QM57
● System Memory		Up to 8 GB (DDR3 800/1066 MHz, SODIMM x 2)
● Display Interface	VGA	1
	DVI	1
● Storage Device	SSD	Optional
	HDD	2.5" HDD x 1
● Network	LAN	10/100/1000Base-TX x 4
● Front I/O	USB Host	USB2.0 x 4
● Rear I/O	USB Host	USB2.0 x 4
	LAN	RJ-45 x 4
	Serial Port	COM x 9 (with isolation x 8)
	DIO	8-bit (4-in/4-out)
	KB/MS	1
● Indicator	Front	HDD x 1, PWR x 1, LAN x 4, COM x 9
● Power Requirement		10~30V DC-in
● Power Consumption		Intel® Core™ i7-620M, 35W
● System Cooling		Passive Cooling
● Mounting		1.5U 19" Rackmount
● Operating Temperature		32°F~113°F (0°C~45°C)

● Storage Temperature	-4°F~140°F (-20°C~60°C)
● Anti-Vibration	1 g rms/ 5~500 Hz/ Operation
● Anti-Shock	30 G with 11 m/sec., Operation
● Certification	EMC CE/FCC
● Dimension (W x H x D)	16.9" x 11.8" x 2.36" (430mm x 300mm x 60mm)

1.4 General System Information

Front Panel

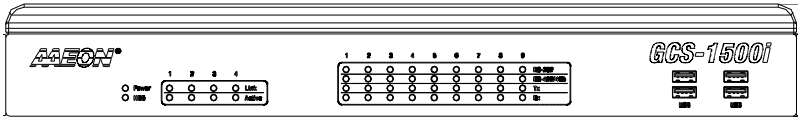

Rear Panel

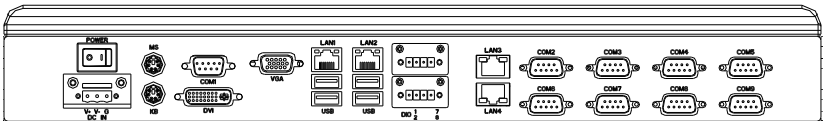

Chapter

2

**Hardware
Installation**

2.1 Location of Jumpers and Connectors

IMBI-QM57 Component Side

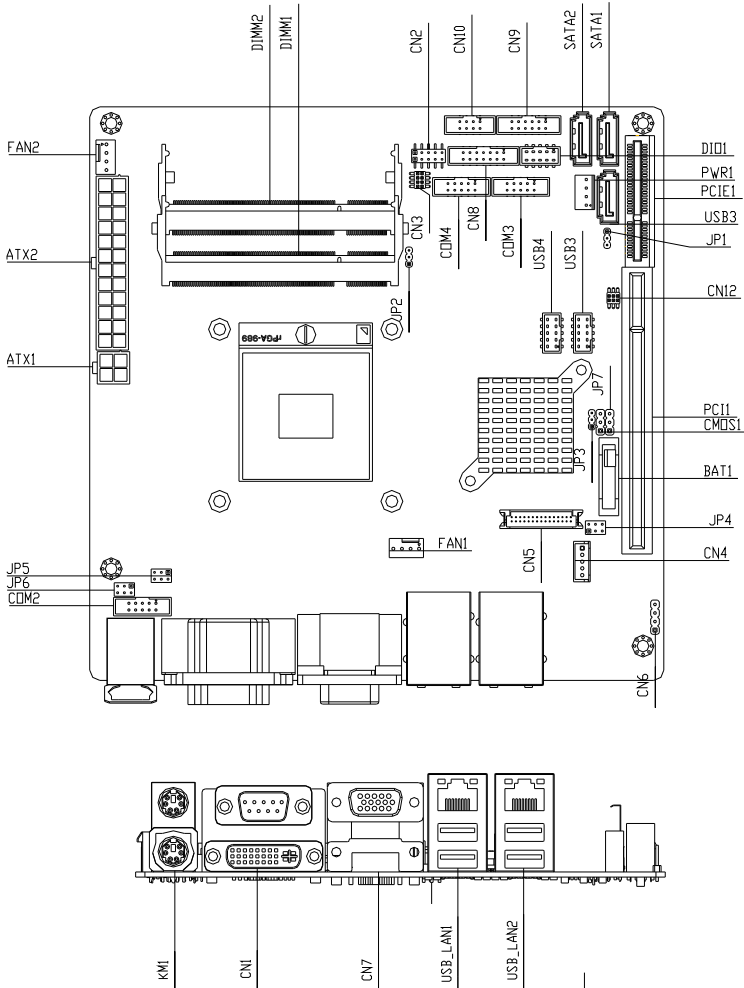

IMBI-QM57 Solder Side

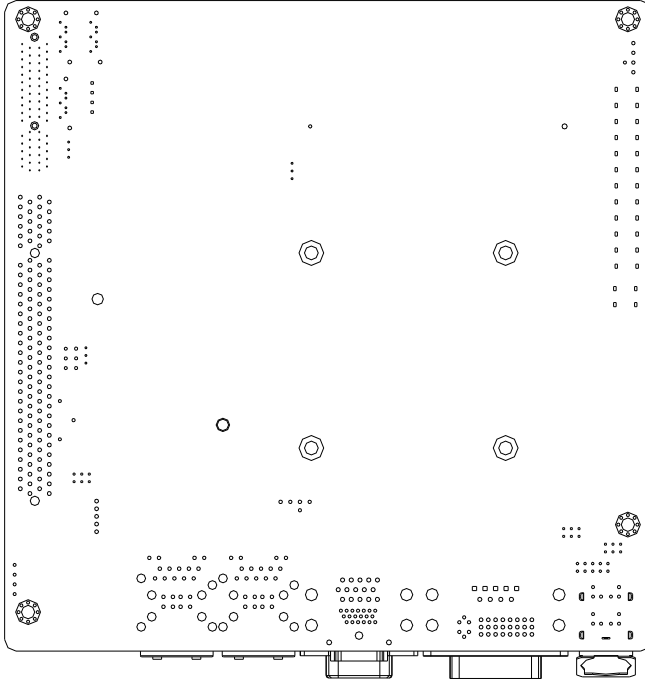

PER-T166

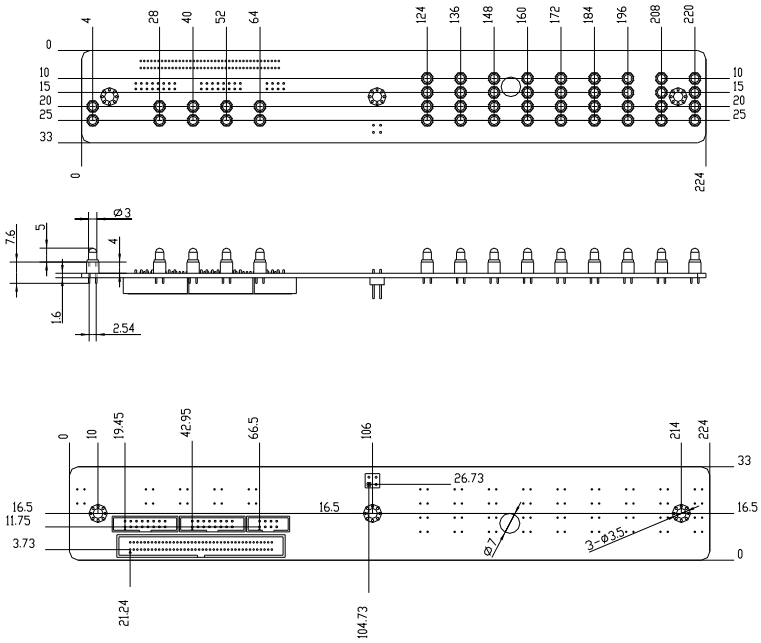

PER-T167

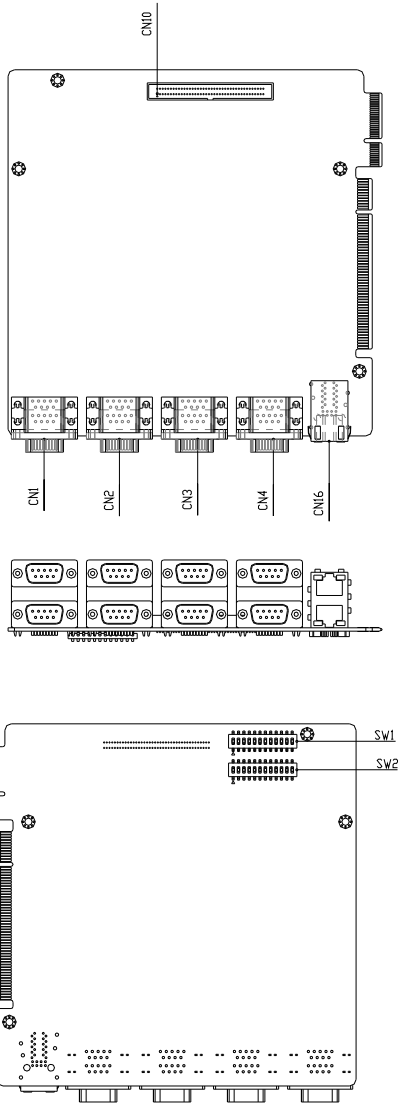

PER-T171

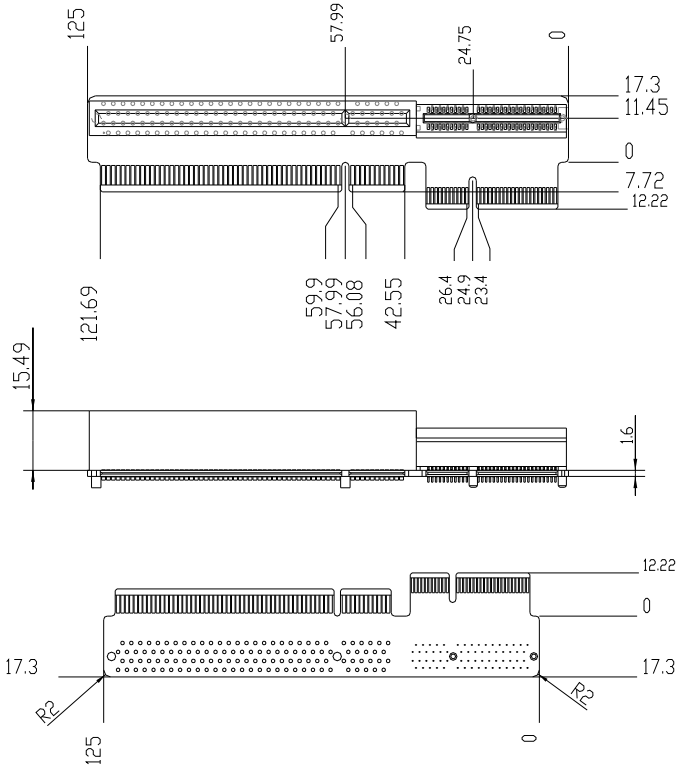

2.2 Mechanical Drawings

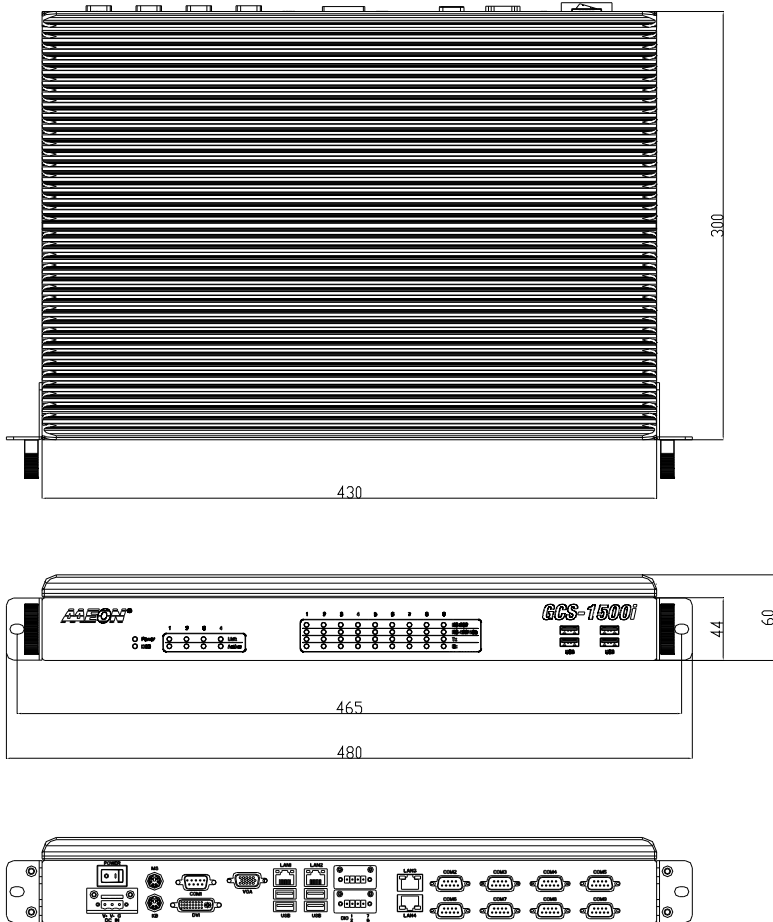

2.3 Setting Jumpers

You configure your card to match the needs of your application by setting jumpers. A jumper is the simplest kind of electric switch. It consists of two metal pins and a small metal clip (often protected by a plastic cover) that slides over the pins to connect them. To “close” a jumper you connect the pins with the clip.

To “open” a jumper you remove the clip. Sometimes a jumper will have three pins, labeled 1, 2 and 3. In this case you would connect either pins 1 and 2 or 2 and 3.

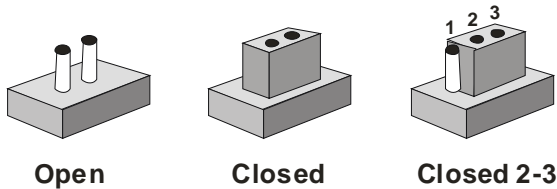

A pair of needle-nose pliers may be helpful when working with jumpers.

If you have any doubts about the best hardware configuration for your application, contact your local distributor or sales representative before you make any change.

Generally, you simply need a standard cable to make most connections.

2.4 Pin Definition of IMBI-QM57

List of Jumpers

The board has a number of jumpers that allow you to configure your system to suit your application.

The table below shows the function of each of the board's jumpers:

Label	Function
CMOS1	CMOS Setting Selection
JP1	Auto PWRBTN Selection
JP2	CFD Voltage 3.3V/5V Selection
JP3	TPM Setting Selection
JP4	LCD Power and Inverter Power Selection
JP5	COM1 +12V/+5V/RING Selection
JP6	COM2 +12V/+5V/RING Selection
JP7	PCH LDRQ1# +3.3V/GND Selection

List of Connectors

The board has a number of connectors that allow you to configure your system to suit your application. The table below shows the function of each board's connectors:

Label	Function
CN1	DVI-I & COM Port Connector
CN2	Front Panel Connector
CN4	LCD Inverter Power Connector
CN5	LVDS Connector
CN6	CD-IN
CN7	VGA Connector
CN8	COM1~2 Port LED
CN9	COM3~4 Port LED

CN10	LAN Port LED
COM2	RS-232 /422/485 Pin Header
COM3	RS-232 Pin header
COM4	RS-232 Pin header
KM1	PS2 Keyboard/Mouse Connector
USB_LAN1	100/1000Base-TX Ethernet & Dual USB Connector
USB_LAN2	100/1000Base-TX Ethernet & Dual USB Connector
DIMM1,DIMM2	DDR3 DIMM Slot
USB3,USB4	USB Pin Header
FAN1, FAN2	4-Pin System Fan Connector
ATX1	4-Pin ATX Power +12V Connector
ATX2	24-Pin ATX Power
SATA1~SATA3	SATA Connector
DIO1	Digital I/O
PIC1	PCI Slot
PCIE1	PCIE Slot
PWR1	SATA Power Connector

CMOS Setting (CMOS1)

JP1	Function
1-2	Normal (Default)
2-3	Clear CMOS

Auto PWRBTN Selection (JP1)

JP1	Function
1-2	Don't use Auto PWRBTN (Default)

2-3 Use Auto PWRBTN

CFD Voltage 3.3V/5V Selection (JP2)

JP2	Function
1-2	+3.3V
2-3	+5V (Default)

TPM Setting (JP3)

JP3	Function
1-2	Save ME RTC Register (Default)
2-3	Clear ME RTC Register

LCD Power and Inverter Power Selection (JP4)

JP4	Function
1-3	Inverter Power +5V (Default)
3-5	Inverter Power +12V
4-6	LCD Power +3.3V (Default)
2-4	LCD Power +5V

COM1 +12V/+5V/RING Selection (JP5)

JP5	Function
1-2	+12V
3-4	Ring (Default)
5-6	+5V

COM2 +12V/+5V/RING Selection (JP6)

JP6	Function
1-2	+12V

3-4	Ring (Default)
5-6	+5V

PCH LDRQ1# 3.3V/GND Selection (JP7)

JP7	Function
1-2	+3.3V (Default)
2-3	GND

Front Panel Connector (CN2)

Pin	Signal	Pin	Signal
1	Power On Button (-)	2	Power On Button (+)
3	HDD LED(-)	4	HDD LED(+)
5	External Speaker (-)	6	External Speaker (+)
7	Power LED (-)	8	Power LED (+)
9	Reset Switch (-)	10	Reset Switch (+)

LVDS Inverter (CN4)

Pin	Signal
1	12V / 5V
2	VCON
3	GND
4	GND
5	INV_EN

LVDS Connector (CN5)

Pin	Signal	Pin	Signal
1	BKL_EN	2	N.C.
3	VLCD	4	GND
5	LA_CLK#	6	LA_CLK

7	VLCD	8	GND
9	LA_DATA0#	10	LA_DATA0
11	LA_DATA1#	12	LA_DATA1
13	LA_DATA2#	14	LA_DATA2
15	LA_DATA3#	16	LA_DATA3
17	LVDS_DDC_DATA	18	LVDS_DDC_CLK
19	LB_DATA0#	20	LB_DATA0
21	LB_DATA1#	22	LB_DATA1
23	LB_DATA2#	24	LB_DATA2
25	LB_DATA3#	26	LB_DATA3
27	VLCD	28	GND
29	LB_CLK#	30	LB_CLK

CD-IN Pin Header (CN6)

Pin	Signal
1	CD-R
2	CD-GND
3	CD-GND
4	CD-L

COM1~2 Port LED Connector (CN8)

Pin	Signal	Pin	Signal
1	COM1_RS232_PWR	2	GND
3	TX_LED_COM1	4	GND
5	RX_LED_COM1	6	GND
7	COM2_RS232_PWR	8	GND
9	TX_LED_COM2	10	GND
11	RX_LED_COM2	12	GND
13	COM2_RS485_PWR	14	COM2_RS422_PWR

COM3~4 Port LED Connector (CN9)

Pin	Signal	Pin	Signal
1	COM3_RS232_PWR	2	GND
3	TX_LED_COM3	4	GND
5	RX_LED_COM3	6	GND
7	COM4_RS232_PWR	8	GND
9	TX_LED_COM4	10	GND
11	RX_LED_COM4	12	GND

LAN Port LED Connector (CN10)

Pin	Signal	Pin	Signal
1	LAN1_LED_D2	2	LAN1_LED_LNK#_ACT
3	LAN1_LED_1000#	4	LAN1_LED_100#
5	LAN2_LED_D2	6	ACT_2_LED
7	SPD1K_2_LED	8	SPD100_2_LED

RS-232/422/485 Pin Header (COM2)

Pin	Signal	Pin	Signal
1	DCD	2	RXD
3	TXD	4	DTR
5	GND	6	DSR
7	RTS	8	CTS
9	RI		

RS-232 Pin Header (COM3)

Pin	Signal	Pin	Signal
1	DCD	2	RXD
3	TXD	4	DTR
5	GND	6	DSR
7	RTS	8	CTS

9	RI	10	N.C
---	----	----	-----

RS-232 Pin Header (COM4)

Pin	Signal	Pin	Signal
1	DCD	2	RXD
3	TXD	4	DTR
5	GND	6	DSR
7	RTS	8	CTS
9	RI	10	N.C

Pin Header (USB3, USB4)

Pin	Signal	Pin	Signal
1	+5V	2	GND
3	USBD1-	4	GND
5	USBD1+	6	USBD2+
7	GND	8	USBD2-
9	GND	10	+5V

FAN Connector (FAN1, FAN2)

Pin	Signal	Pin	Signal
1	GND	2	+12V
3	FAN_TAC	4	FAN_CTL

4-pin ATX Power Connector (ATX1)

Pin	Signal	Pin	Signal
1	GND	2	GND
3	+12V	4	+12V

24-pin ATX Power Connector (ATX2)

Pin	Signal	Pin	Signal
1	+3.3V	2	+3.3V
3	GND	4	+5V
5	GND	6	+5V
7	GND	8	PWROK
9	+5VSB	10	+12V
11	+12V	12	+3.3V
13	+3.3V	14	-12V
15	GND	16	PS_ON
17	GND	18	GND
19	GND	20	NC
21	+5V	22	+5V
23	+5V	24	GND

SATA Connector (SATA 1~3)

Pin	Signal	Pin	Signal
1	GND	2	TXP
3	TXN	4	GND
5	RXN	6	RXP
7	GND		

Digital I/O Pin Header (DIO1)

The Base Address are A40H, A42H, and A43H

Pin	Signal	Pin	Signal
1	IN0 (U5 Pin34)	2	IN1 (U5 Pin33)
3	IN2 (U5 Pin32)	4	IN3 (U5 Pin31)
5	OUT0 (U5 Pin12)	6	OUT1 (U5 Pin11)
7	OUT2 (U5 Pin70)	8	OUT3 (U5 Pin66)

9	+5V	10	GND
---	-----	----	-----

BIOS Setting	Connector Definition	Address	IT8781F GPIO Setting
DIO_P#1	BC3 Pin 1	Bit 1(A40H)	U5 Pin 34 (GPIO11)
DIO_P#2	BC3 Pin 2	Bit 2(A40H)	U5 Pin 33 (GPIO12)
DIO_P#3	BC3 Pin 3	Bit 3(A40H)	U5 Pin 32 (GPIO13)
DIO_P#4	BC3 Pin 4	Bit 4(A40H)	U5 Pin 31 (GPIO14)
DIO_P#5	BC3 Pin 5	Bit 6(A42H)	U5 Pin 12 (GPIO36)
DIO_P#6	BC3 Pin 6	Bit 7(A42H)	U5 Pin 11 (GPIO37)
DIO_P#7	BC3 Pin 7	Bit 6(A43H)	U5 Pin 70 (GPIO46)
DIO_P#8	BC3 Pin 8	Bit 7(A43H)	U5 Pin 66 (GPIO47)

Note:

1. DIO_P#1, DIO_P#2, DIO_P#3, DIO_P#4 use Base Address: A40H
2. DIO_P#5, DIO_P#6 use Base Address: A42H
3. DIO_P#7, DIO_P#8 use Base Address: A43H

SATA Power Connector (PWR1)

Pin	Signal	Pin	Signal
1	+12V	2	GND
3	GND	4	+5V

2.5 Pin Definition of PER-T167

List of Jumpers

Label	Function
SW1	COM1 ~ COM4 Mode Selection
SW2	COM5 ~ COM8 Mode Selection

List of Connectors

Label	Function
CN1	COM4/COM8 Connector
CN2	COM3/COM7 Connector
CN3	COM2/COM6 Connector
CN4	COM1/COM5 Connector
CN10	COM / LAN LED Connector

COM1~COM4 Mode Selection (SW1)

Pin	Signal	ON / OFF	Note
1	ENRS232_1T	ON (Default)	
2	ENRS485#_1T	OFF	COM1 RS-232 Mode
3	ENRS422#_1T	OFF	
4	ENRS232_2T	ON (Default)	
5	ENRS485#_2T	OFF	COM2 RS-232 Mode
6	ENRS422#_2T	OFF	
7	ENRS232_3T	ON (Default)	
8	ENRS485#_3T	OFF	COM3 RS-232 Mode
9	ENRS422#_3T	OFF	
10	ENRS232_4T	ON (Default)	
11	ENRS485#_4T	OFF	COM4 RS-232 Mode
12	ENRS422#_4T	OFF	

Pin	Signal	ON / OFF	Note
1	ENRS232_1T	OFF	
2	ENRS485#_1T	ON	COM1 RS-485 Mode
3	ENRS422#_1T	OFF	
4	ENRS232_2T	OFF	
5	ENRS485#_2T	ON	COM2 RS-485 Mode
6	ENRS422#_2T	OFF	
7	ENRS232_3T	OFF	
8	ENRS485#_3T	ON	COM3 RS-485 Mode
9	ENRS422#_3T	OFF	
10	ENRS232_4T	OFF	
11	ENRS485#_4T	ON	COM4 RS-485 Mode
12	ENRS422#_4T	OFF	

Pin	Signal	ON / OFF	Note
1	ENRS232_1T	OFF	
2	ENRS485#_1T	OFF	COM1 RS-422 Mode
3	ENRS422#_1T	ON	
4	ENRS232_2T	OFF	
5	ENRS485#_2T	OFF	COM2 RS-422 Mode
6	ENRS422#_2T	ON	
7	ENRS232_3T	OFF	
8	ENRS485#_3T	OFF	COM3 RS-422 Mode
9	ENRS422#_3T	ON	
10	ENRS232_4T	OFF	
11	ENRS485#_4T	OFF	COM4 RS-422 Mode
12	ENRS422#_4T	ON	

COM5 ~ COM8 Mode Selection (SW2)

Pin	Signal	ON / OFF	Note
1	ENRS232_5T	ON	
2	ENRS485#_5T	OFF	COM5 RS-232 Mode
3	ENRS422#_5T	OFF	
4	ENRS232_6T	ON	
5	ENRS485#_6T	OFF	COM6 RS-232 Mode
6	ENRS422#_6T	OFF	
7	ENRS232_7T	ON	
8	ENRS485#_7T	OFF	COM7 RS-232 Mode
9	ENRS422#_7T	OFF	
10	ENRS232_8T	ON	
11	ENRS485#_8T	OFF	COM8 RS-232 Mode
12	ENRS422#_8T	OFF	

Pin	Signal	ON / OFF	Note
1	ENRS232_5T	OFF	
2	ENRS485#_5T	ON	COM5 RS485 Mode
3	ENRS422#_5T	OFF	
4	ENRS232_6T	OFF	
5	ENRS485#_6T	ON	COM6 RS485 Mode
6	ENRS422#_6T	OFF	
7	ENRS232_7T	OFF	
8	ENRS485#_7T	ON	COM7 RS4-85 Mode
9	ENRS422#_7T	OFF	
10	ENRS232_8T	OFF	
11	ENRS485#_8T	ON	COM8 RS-485 Mode
12	ENRS422#_8T	OFF	

Pin	Signal	ON / OFF	Note
1	ENRS232_5T	OFF	
2	ENRS485#_5T	OFF	COM5 RS-422 Mode
3	ENRS422#_5T	ON	
4	ENRS232_6T	OFF	
5	ENRS485#_6T	OFF	COM6 RS-422 Mode
6	ENRS422#_6T	ON	
7	ENRS232_7T	OFF	
8	ENRS485#_7T	OFF	COM7 RS-422 Mode
9	ENRS422#_7T	ON	
10	ENRS232_8T	OFF	
11	ENRS485#_8T	OFF	COM8 RS-422 Mode
12	ENRS422#_8T	ON	

COM / LAN LED Connector (CN10)

Pin	Signal	Pin	Signal
1	RS422_PWR_COM8	2	RS485_PWR_COM8
3	GND	4	RS232_PWR_COM8
5	RS422_PWR_COM7	6	RS485_PWR_COM7
7	GND	8	RS232_PWR_COM7
9	RS422_PWR_COM6	10	RS485_PWR_COM6
11	GND	12	RS232_PWR_COM6
13	RS422_PWR_COM5	14	RS485_PWR_COM5
15	GND	16	RS232_PWR_COM5
17	RS422_PWR_COM4	18	RS485_PWR_COM4
19	GND	20	RS232_PWR_COM4
21	RS422_PWR_COM3	22	RS485_PWR_COM3
23	GND	24	RS232_PWR_COM3
25	RS422_PWR_COM2	26	RS485_PWR_COM2

27	GND	28	RS232_PWR_COM2
29	RS422_PWR_COM1	30	RS485_PWR_COM1
31	GND	32	RS232_PWR_COM1
33	NC	34	NC
35	-TX_LED_COM1	36	TX_LED_COM1
37	-TX_LED_COM2	38	TX_LED_COM2
39	-TX_LED_COM3	40	TX_LED_COM3
41	-TX_LED_COM4	42	TX_LED_COM4
43	-TX_LED_COM5	44	TX_LED_COM5
45	-TX_LED_COM6	46	TX_LED_COM6
47	-TX_LED_COM7	48	TX_LED_COM7
49	-TX_LED_COM8	50	TX_LED_COM7
51	NC	52	NC
53	-RX_LED_COM1	54	RX_LED_COM1
55	-RX_LED_COM2	56	RX_LED_COM2
57	-RX_LED_COM3	58	RX_LED_COM3
59	-RX_LED_COM4	60	RX_LED_COM4
61	-RX_LED_COM5	62	RX_LED_COM5
63	-RX_LED_COM6	64	RX_LED_COM6
65	-RX_LED_COM7	66	RX_LED_COM7
67	-RX_LED_COM8	68	RX_LED_COM8
69	NC	70	NC
71	ACT_L1-	72	ACT_L1+
73	LINK100_L1	74	LINK1000_L1
75	ACT_L2-	76	ACT_L2+
77	LINK100_L2	78	LINK1000_L2
79	NC	80	NC

2.6 CPU And RAM Module Installation

Step 1: Place the CPU and cover the CPU bracket



Step 2: Fasten the four screws to fix the CPU bracket and stick the thermal pad on the bracket



Step 3: Tearing the release paper up



Step 5: Get the SODIMM stuck with thermal pad ready

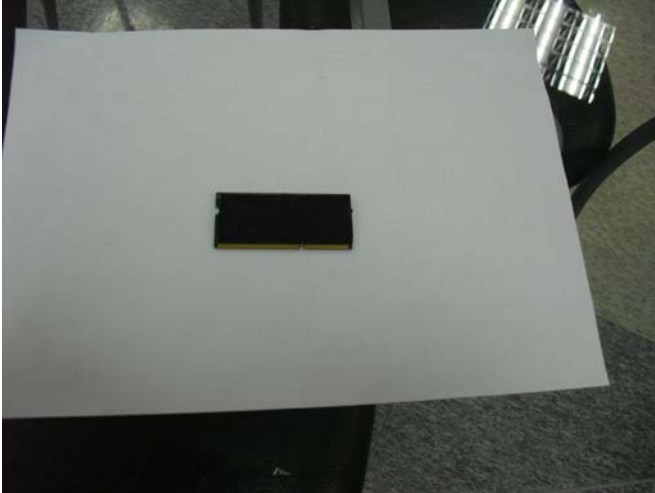

Step 6: Install the SODIMM to the lower layer of memory slot



Step 7: Install the second SODIMM to the upper layer of memory slot



Step 8: Close the bottom case of the GCS-1500i



Step 9: Fasten the two screws on the right and left case of GCS-1500i and you've done installing the CPU and RAM module



Chapter

3

**AMI
BIOS Setup**

3.1 System Test and Initialization

These routines test and initialize board hardware. If the routines encounter an error during the tests, you will either hear a few short beeps or see an error message on the screen. There are two kinds of errors: fatal and non-fatal. The system can usually continue the boot up sequence with non-fatal errors.

System configuration verification

These routines check the current system configuration against the values stored in the CMOS memory. If they do not match, the program outputs an error message. You will then need to run the BIOS setup program to set the configuration information in memory.

There are three situations in which you will need to change the CMOS settings:

1. You are starting your system for the first time
2. You have changed the hardware attached to your system
3. The CMOS memory has lost power and the configuration information has been erased.

The GCS-1500i CMOS memory has an integral lithium battery backup for data retention. However, you will need to replace the complete unit when it finally runs down.

3.2 AMI BIOS Setup

AMI BIOS ROM has a built-in Setup program that allows users to modify the basic system configuration. This type of information is stored in battery-backed CMOS RAM so that it retains the Setup information when the power is turned off.

Entering Setup

Power on the computer and press or <F2> immediately. This will allow you to enter Setup.

Main

Set the date, use tab to switch between date elements.

Advanced

Enable/disable boot option for legacy network devices.

Chipset

Host bridge parameters.

Boot

Enables/disables quiet boot option.

Security

Set setup administrator password.

Save&Exit

Exit system setup after saving the changes.

Chapter

4

**Driver
Installation**

The GCS-1500i comes with a CD-ROM that contains all drivers your need.

Follow the sequence below to install the drivers:

- Step 1 – Install Chipset Driver
- Step 2 – Install VGA Driver
- Step 3 – Install LAN Driver
- Step 4 – Install AUDIO Driver
- Step 5 – Install ME Driver
- Step 6 – Install System Base Driver

Please read following instructions for detailed installations.

4.1 Installation:

Insert the GCS-1500i DVD-ROM into the DVD-ROM Drive. And install the drivers from Step 1 to Step 6 in order.

Step 1 – Install Chipset Driver

1. Click on the **STEP1-CHIPSET** folder and select the OS your system is
2. Double click on the **Setup.exe** file located in each OS folder
3. Follow the instructions that the window shows
4. The system will help you to install the driver automatically

Step 2 – Install VGA Driver

1. Click on the **STEP2-VGA** folder and select the OS your system is
2. Double click on **.exe** file located in each OS folder
3. Follow the instructions that the window shows
4. The system will help you to install the driver automatically

Step 3 – Install LAN Driver

1. Click on the **STEP3-LAN** folder and select the OS your system is
2. Double click on **Autorun.exe** file located in each OS folder
3. Follow the instructions that the window shows
4. The system will help you to install the driver automatically

Step 4 – Install AUDIO Driver

1. Click on the **STEP4-AUDIO** folder and select the OS your system is
2. Double click on **.exe** file located in each OS folder
3. Follow the instructions that the window shows
4. The system will help you to install the driver automatically

Step 5 – Install ME Driver

1. Click on the **STEP5-ME** folder and select the OS your system is
2. Double click on **Setup.exe** file located in each OS folder
3. Follow the instructions that the window shows
4. The system will help you to install the driver automatically

Step 6 – Install System Base Driver

1. Click on the **STEP6-System Base** folder and select the OS your system is
2. It must be installed by INF file
3. Follow the instructions that the window shows
4. The system will help you to install the driver automatically

Appendix

A

Programming the Watchdog Timer

A.1 Programming

GCS-1500i utilizes ITE 8781 chipset as its watchdog timer controller. Below are the procedures to complete its configuration and the AAEON initial watchdog timer program is also attached based on which you can develop customized program to fit your application.

Configuring Sequence Description

After the hardware reset or power-on reset, the ITE 8781 enters the normal mode with all logical devices disabled except KBC. The initial state (enable bit) of this logical device (KBC) is determined by the state of pin 121 (DTR1#) at the falling edge of the system reset during power-on reset.

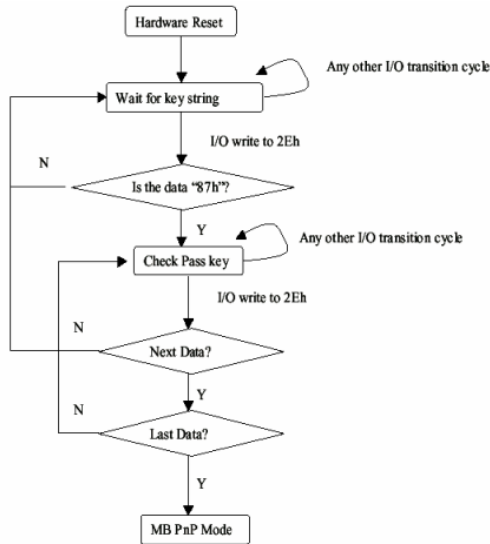

There are three steps to complete the configuration setup: (1) Enter the MB PnP Mode; (2) Modify the data of configuration registers; (3) Exit the MB PnP Mode. Undesired result may occur if the MB PnP Mode is not exited normally.

(1) Enter the MB PnP Mode

To enter the MB PnP Mode, four special I/O write operations are to be performed during Wait for Key state. To ensure the initial state of the key-check logic, it is necessary to perform four write operations to the Special Address port (2EH). Two different enter keys are provided to select configuration ports (2Eh/2Fh) of the next step.

	Address Port	Data Port
87h, 01h, 55h, 55h:	2Eh	2Fh

(2) Modify the Data of the Registers

All configuration registers can be accessed after entering the MB PnP Mode. Before accessing a selected register, the content of Index 07h must be changed to the LDN to which the register belongs, except some Global registers.

(3) Exit the MB PnP Mode

Set bit 1 of the configure control register (Index=02h) to 1 to exit the MB PnP Mode.

WatchDog Timer Configuration Registers

LDN	Index	R/W	Reset	Configuration Register or Action
All	02h	W	NA	Configure Control

07h	71h	R/W	00h	Watch Dog Timer Control Register
07h	72h	R/W	001s0000b	Watch Dog Timer Configuration Register
07h	73h	R/W	38h	Watch Dog Timer Time-out Value (LSB) Register
07h	74h	R/W	00h	Watch Dog Timer Time-out Value (MSB) Register

Configure Control (Index=02h)

This register is write only. Its values are not sticky; that is to say, a hardware reset will automatically clear the bits, and does not require the software to clear them.

Bit	Description
7-2	Reserved
1	Returns to the "Wait for Key" state. This bit is used when the configuration sequence is completed.
0	Resets all logical devices and restores configuration registers to their power-on states.

Watch Dog Timer 1, 2, 3 Control Register (Index=71h,81h,91h Default=00h)

Bit	Description
7	WDT Timeout Enable(WTE) 1: Disable. 0: Enable.
6	WDT Reset upon Mouse Interrupt(WRKMI) 0: Disable. 1: Enable.
5	WDT Reset upon Keyboard Interrupt(WRKBI) 0: Disable. 1: Enable.
4	Reserved
3-2	Reserved
1	Force Time-out(FTO) This bit is self-clearing.
0	WDT Status(WS) 1: WDT value reaches 0. 0: WDT value is not 0.

**Watch Dog Timer 1, 2, 3 Configuration Register (Index=72h,
82h, 92h Default=001s0000b)**

Bit	Description
7	WDT Time-out Value Select 1 (WTVS) 1: Second 0: Minute
6	WDT Output through KRST (Pulse) Enable(WOKE) 1: Enable 0: Disable
5	WDT Time-out value Extra select(WTVES) 1: 64ms x WDT Timer-out value (default = 4s) 0: Determined by WDT Time-out value select 1 (bit 7 of this register)
4	WDT Output through PWROK (Pulse) Enable(WOPE) 1: Enable 0: Disable During LRESET#, this bit is selected by JP7 power-on strapping option
3-0	Select interrupt level^{Note1} for WDT(SIL)

**Watch Dog Timer 1,2,3 Time-Out Value (LSB) Register
(Index=73h,83h,93h, Default=38h)**

Bit	Description
7-0	WDT Time-out Value 7-0(WTV)

**Watch Dog Timer 1,2,3 Time-Out Value (MSB) Register
(Index=74h,84h,94h Default=00h)**

Bit	Description
7-0	WDT Time-out Value 15-8(WTV)

A.2 ITE8781 Watchdog Timer Initial Program

```
.MODEL SMALL
.CODE
Main:
CALL Enter_Configuration_mode
CALL Check_Chip
mov cl, 7
call Set_Logic_Device
;time setting
mov cl, 10 ; 10 Sec
dec al
Watch_Dog_Setting:
;Timer setting
mov al, cl
mov cl, 73h
call Superio_Set_Reg
;Clear by keyboard or mouse interrupt
mov al, 0f0h
mov cl, 71h
call Superio_Set_Reg
;unit is second.
mov al, 0C0H
mov cl, 72h
```

```
call Superio_Set_Reg  
; game port enable  
mov cl, 9  
call Set_Logic_Device
```

```
Initial_OK:  
CALL Exit_Configuration_mode  
MOV AH,4Ch  
INT 21h
```

```
Enter_Configuration_Mode PROC NEAR  
MOV SI,WORD PTR CS:[Offset Cfg_Port]
```

```
MOV DX,02Eh  
MOV CX,04h  
Init_1:  
MOV AL,BYTE PTR CS:[SI]  
OUT DX,AL  
INC SI  
LOOP Init_1  
RET  
Enter_Configuration_Mode ENDP
```

```
Exit_Configuration_Mode PROC NEAR  
MOV AX,0202h
```

```
CALL Write_Configuration_Data  
RET  
Exit_Configuration_Mode ENDP
```

```
Check_Chip PROC NEAR
```

```
MOV AL,20h  
CALL Read_Configuration_Data  
CMP AL,87h  
JNE Not_Initial
```

```
MOV AL,21h  
CALL Read_Configuration_Data  
CMP AL,81h  
JNE Not_Initial
```

```
Need_Initial:
```

```
STC
```

```
RET
```

```
Not_Initial:
```

```
CLC
```

```
RET
```

```
Check_Chip ENDP
```

```
Read_Configuration_Data PROC NEAR
```

```
MOV DX,WORD PTR CS:[Cfg_Port+04h]
```

```
OUT DX,AL
MOV DX,WORD PTR CS:[Cfg_Port+06h]
IN AL,DX
RET
Read_Configuration_Data ENDP
```

```
Write_Configuration_Data PROC NEAR
MOV DX,WORD PTR CS:[Cfg_Port+04h]
OUT DX,AL
XCHG AL,AH
MOV DX,WORD PTR CS:[Cfg_Port+06h]
OUT DX,AL
RET
Write_Configuration_Data ENDP
```

```
Superio_Set_Reg proc near
push ax
MOV DX,WORD PTR CS:[Cfg_Port+04h]
mov al,cl
out dx,al
pop ax
inc dx
out dx,al
ret
Superio_Set_Reg endp.Set_Logic_Device proc near
```

```
Set_Logic_Device    proc    near
push ax
push cx
xchg al,cl
mov cl,07h
call Superio_Set_Reg
pop cx
pop ax
ret
Set_Logic_Device endp
```

```
;Select 02Eh->Index Port, 02Fh->Data Port
Cfg_Port DB 087h,001h,055h,055h
DW 02Eh,02Fh
```

END Main

Note: Interrupt level mapping

0Fh-Dh: not valid

0Ch: IRQ12

.

.

03h: IRQ3

02h: not valid

01h: IRQ1

00h: no interrupt selected

Appendix

B

I/O Information

B.1 I/O Address Map

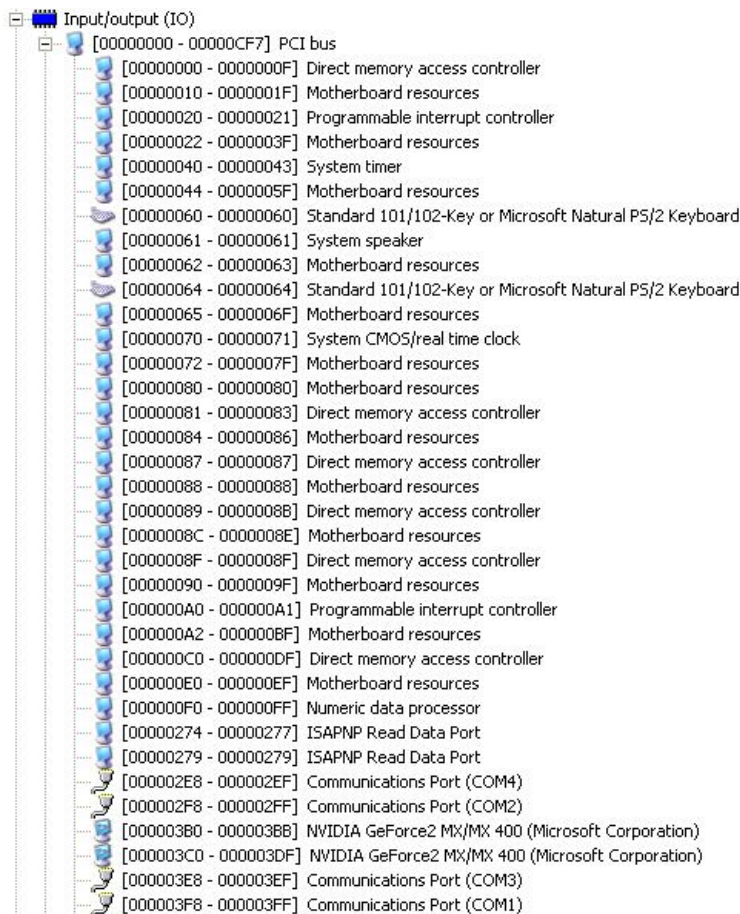

Input/output (IO)	
[00000000 - 00000CF7] PCI bus	
[00000000 - 0000000F] Direct memory access controller	
[00000010 - 0000001F] Motherboard resources	
[00000020 - 00000021] Programmable interrupt controller	
[00000022 - 0000003F] Motherboard resources	
[00000040 - 00000043] System timer	
[00000044 - 0000005F] Motherboard resources	
[00000060 - 00000060] Standard 101/102-Key or Microsoft Natural PS/2 Keyboard	
[00000061 - 00000061] System speaker	
[00000062 - 00000063] Motherboard resources	
[00000064 - 00000064] Standard 101/102-Key or Microsoft Natural PS/2 Keyboard	
[00000065 - 0000006F] Motherboard resources	
[00000070 - 00000071] System CMOS/real time clock	
[00000072 - 0000007F] Motherboard resources	
[00000080 - 00000080] Motherboard resources	
[00000081 - 00000083] Direct memory access controller	
[00000084 - 00000086] Motherboard resources	
[00000087 - 00000087] Direct memory access controller	
[00000088 - 00000088] Motherboard resources	
[00000089 - 0000008B] Direct memory access controller	
[0000008C - 0000008E] Motherboard resources	
[0000008F - 0000008F] Direct memory access controller	
[00000090 - 0000009F] Motherboard resources	
[000000A0 - 000000A1] Programmable interrupt controller	
[000000A2 - 000000BF] Motherboard resources	
[000000C0 - 000000DF] Direct memory access controller	
[000000E0 - 000000EF] Motherboard resources	
[000000F0 - 000000FF] Numeric data processor	
[00000274 - 00000277] ISAPNP Read Data Port	
[00000279 - 00000279] ISAPNP Read Data Port	
[000002E8 - 000002EF] Communications Port (COM4)	
[000002F8 - 000002FF] Communications Port (COM2)	
[000003B0 - 000003BB] NVIDIA GeForce2 MX/MX 400 (Microsoft Corporation)	
[000003C0 - 000003DF] NVIDIA GeForce2 MX/MX 400 (Microsoft Corporation)	
[000003E8 - 000003EF] Communications Port (COM3)	
[000003F8 - 000003FF] Communications Port (COM1)	

- [00000400 - 0000047F] System board
- [000004D0 - 000004D1] Motherboard resources
- [00000500 - 0000057F] System board
- [00000A00 - 00000A1F] Motherboard resources
- [00000A79 - 00000A79] ISAPNP Read Data Port
- [00000D00 - 0000FFFF] PCI bus
 - [00001180 - 0000119F] System board
 - [0000D000 - 0000DFFF] Intel(R) 5 Series/3400 Series Chipset Family PCI Express Root Port 8 - 3B50
 - [0000E000 - 0000EFFF] Intel(R) 5 Series/3400 Series Chipset Family PCI Express Root Port 6 - 3B4C
 - [0000F000 - 0000F01F] Intel(R) 5 Series/3400 Series Chipset Family SMBus Controller - 3B30
 - [0000F020 - 0000F03F] Intel(R) 82577LM Gigabit Network Connection
 - [0000F040 - 0000F04F] Intel(R) 5 Series/3400 Series Chipset Family 2 port Serial ATA Storage Controller - 3B2D
 - [0000F050 - 0000F05F] Intel(R) 5 Series/3400 Series Chipset Family 2 port Serial ATA Storage Controller - 3B2D
 - [0000F060 - 0000F063] Intel(R) 5 Series/3400 Series Chipset Family 2 port Serial ATA Storage Controller - 3B2D
 - [0000F070 - 0000F077] Intel(R) 5 Series/3400 Series Chipset Family 2 port Serial ATA Storage Controller - 3B2D
 - [0000F080 - 0000F083] Intel(R) 5 Series/3400 Series Chipset Family 2 port Serial ATA Storage Controller - 3B2D
 - [0000F090 - 0000F097] Intel(R) 5 Series/3400 Series Chipset Family 2 port Serial ATA Storage Controller - 3B2D
 - [0000F0A0 - 0000F0AF] Intel(R) 5 Series/3400 Series Chipset Family 4 port Serial ATA Storage Controller - 3B2E
 - [0000F0B0 - 0000F0BF] Intel(R) 5 Series/3400 Series Chipset Family 4 port Serial ATA Storage Controller - 3B2E
 - [0000F0C0 - 0000F0C3] Intel(R) 5 Series/3400 Series Chipset Family 4 port Serial ATA Storage Controller - 3B2E
 - [0000F0D0 - 0000F0D7] Intel(R) 5 Series/3400 Series Chipset Family 4 port Serial ATA Storage Controller - 3B2E
 - [0000F0E0 - 0000F0E3] Intel(R) 5 Series/3400 Series Chipset Family 4 port Serial ATA Storage Controller - 3B2E
 - [0000F0F0 - 0000F0F7] Intel(R) 5 Series/3400 Series Chipset Family 4 port Serial ATA Storage Controller - 3B2E

B.2 1st MB Memory Address Map



B.3 IRQ Mapping Chart

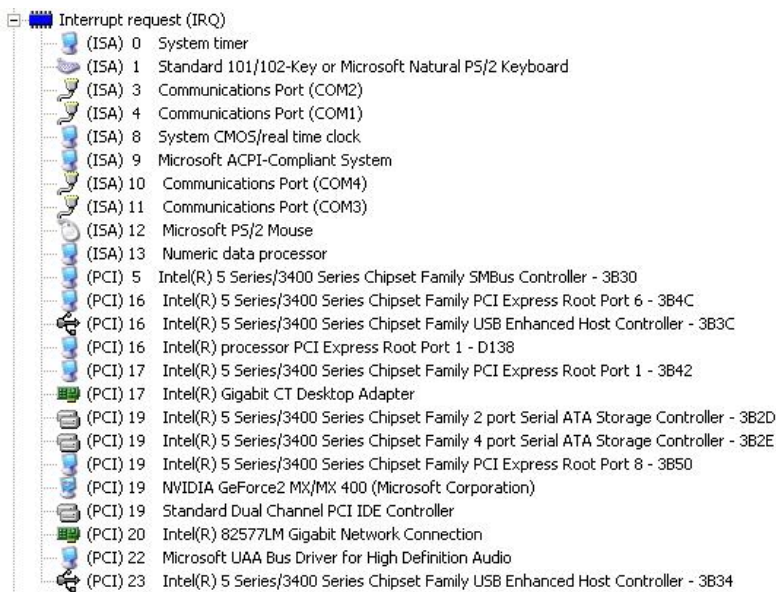

The screenshot shows the 'Interrupt request (IRQ)' section in Windows Device Manager. It lists various hardware components and their assigned IRQs. The list includes ISA, PCI, and USB devices, such as system timers, keyboards, communication ports, mice, and various controllers like SATA, network, and audio.

Device Class	Device Name	IRQ
ISA	System timer	0
ISA	Standard 101/102-Key or Microsoft Natural PS/2 Keyboard	1
ISA	Communications Port (COM2)	3
ISA	Communications Port (COM1)	4
ISA	System CMOS/real time clock	8
ISA	Microsoft ACPI-Compliant System	9
ISA	Communications Port (COM4)	10
ISA	Communications Port (COM3)	11
ISA	Microsoft PS/2 Mouse	12
ISA	Numeric data processor	13
PCI	Intel(R) 5 Series/3400 Series Chipset Family SMBus Controller - 3B30	5
PCI	Intel(R) 5 Series/3400 Series Chipset Family PCI Express Root Port 6 - 3B4C	16
PCI	Intel(R) 5 Series/3400 Series Chipset Family USB Enhanced Host Controller - 3B3C	16
PCI	Intel(R) processor PCI Express Root Port 1 - D138	16
PCI	Intel(R) 5 Series/3400 Series Chipset Family PCI Express Root Port 1 - 3B42	17
PCI	Intel(R) Gigabit CT Desktop Adapter	17
PCI	Intel(R) 5 Series/3400 Series Chipset Family 2 port Serial ATA Storage Controller - 3B2D	19
PCI	Intel(R) 5 Series/3400 Series Chipset Family 4 port Serial ATA Storage Controller - 3B2E	19
PCI	Intel(R) 5 Series/3400 Series Chipset Family PCI Express Root Port 8 - 3B50	19
PCI	NVIDIA GeForce2 MX/MX 400 (Microsoft Corporation)	19
PCI	Standard Dual Channel PCI IDE Controller	19
PCI	Intel(R) 82577LM Gigabit Network Connection	20
PCI	Microsoft UAA Bus Driver for High Definition Audio	22
PCI	Intel(R) 5 Series/3400 Series Chipset Family USB Enhanced Host Controller - 3B34	23

B.4 DMA Channel Assignments

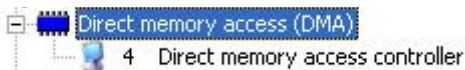

The screenshot shows the 'Direct memory access (DMA)' section in Windows Device Manager. It lists the Direct memory access controller with an assigned DMA channel of 4.

Device Class	Device Name	DMA Channel
PCI	Direct memory access controller	4

Appendix

C

AHCI Settings

C.1 Setting AHCI

OS installation to setup AHCI Mode

Step 1: Copy the files below from “**Driver CD -> Raid Driver -> F6 Floppy - x86**” to Disk

 F6Readme 文字文件 8 KB	 iaAHCI 安全性目錄 9 KB
 iaAHCI 安裝資訊 9 KB	 iaStor 安全性目錄 8 KB
 iaStor 安裝資訊 8 KB	 iaStor 系統檔案 423 KB
 license 文字文件 5 KB	 readme 文字文件 78 KB
 TXTSETUP.OEM OEM 檔案 6 KB	

Step 2: Connect the USB Floppy (disk with RAID files) to the board



Step 3: The setting procedures “In BIOS Setup Menu”

A: Advanced -> SATA Configuration -> SATA Configuration -> SATA Mode -> AHCI Mode

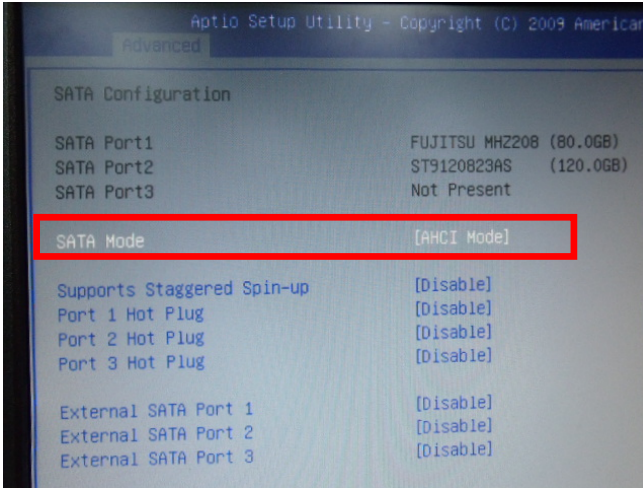

Step 4: The setting procedures “In BIOS Setup Menu”

B: Boot -> Boot Option #1 -> DVD-ROM Type

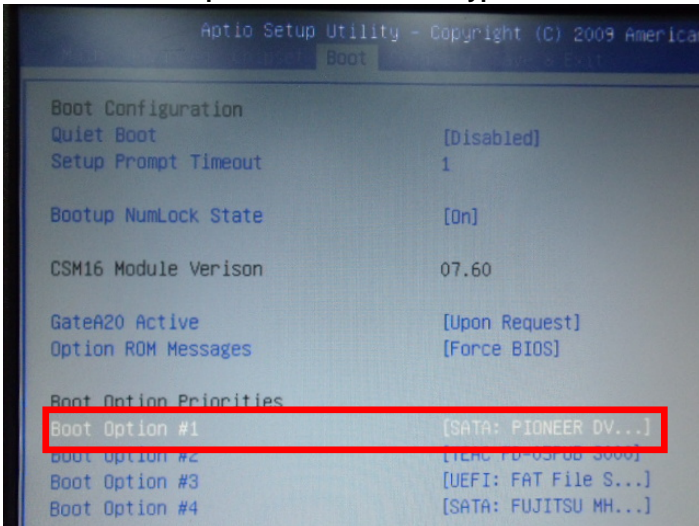

Step 5: The setting procedures “In BIOS Setup Menu”

C: Save & Exit -> Save Changes and Exit

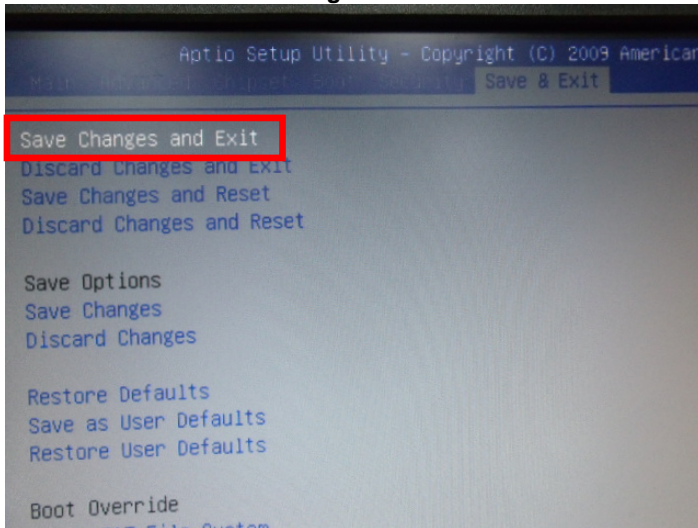

Step 6: Setup OS

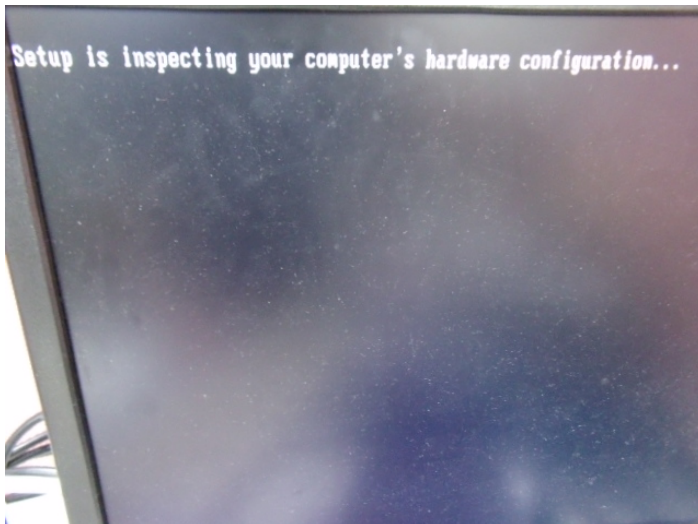

Step 7: Press "F6"



Step 8: Choose "S"

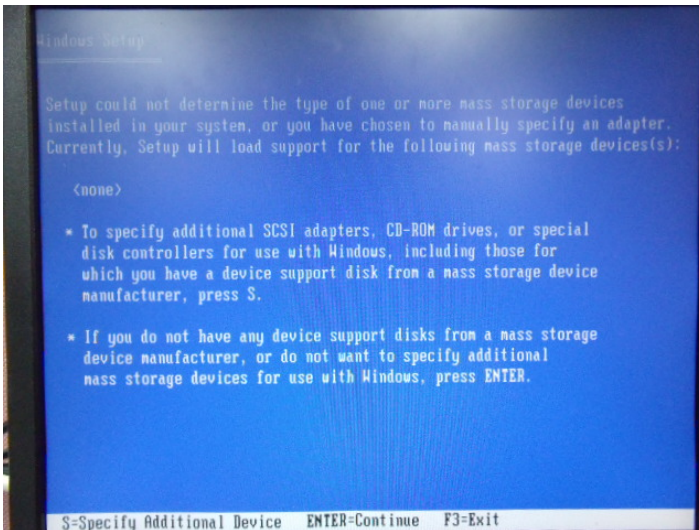

Step 9: Choose "Intel(R) 5 Series 6 Port SATA AHCI Controller"

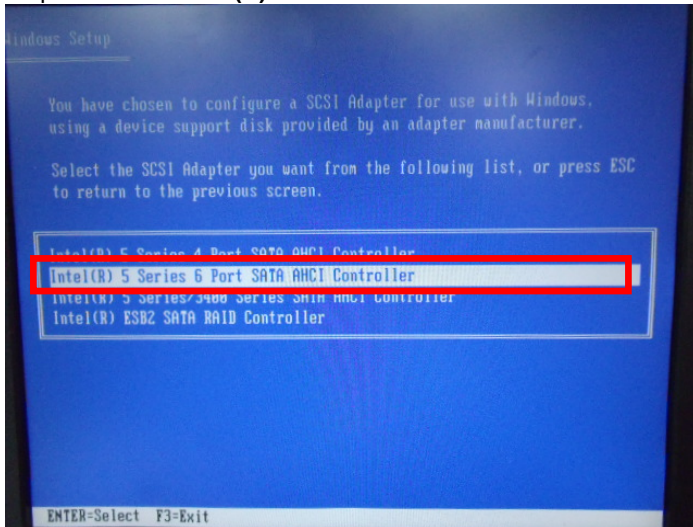

Step 10: It will show the model number you select and then press "ENTER"



Step 11: Setup is loading files

