

Full-size SBC

FSB-B75H

FSB-B75H

Intel® Core™ i7/i5/i3

LGA 1155 Processor

Full-size CPU Card

With DDR3, 2 Gigabit Ethernet

USB 3.0, SATA 6.0Gb/s

FSB-B75H Manual Rev.A 3rd Ed.

June 3, 2014

Copyright Notice

This document is copyrighted, 2014. All rights are reserved. The original manufacturer reserves the right to make improvements to the products described in this manual at any time without notice.

No part of this manual may be reproduced, copied, translated, or transmitted in any form or by any means without the prior written permission of the original manufacturer. Information provided in this manual is intended to be accurate and reliable. However, the original manufacturer assumes no responsibility for its use, or for any infringements upon the rights of third parties that may result from its use.

The material in this document is for product information only and is subject to change without notice. While reasonable efforts have been made in the preparation of this document to assure its accuracy, AAEON assumes no liabilities resulting from errors or omissions in this document, or from the use of the information contained herein.

AAEON reserves the right to make changes in the product design without notice to its users.

Acknowledgments

All other products' name or trademarks are properties of their respective owners.

- AMI is a trademark of American Megatrends Inc.
- Intel[®], Core[™] are trademarks of Intel[®] Corporation.
- Microsoft Windows[®] is a registered trademark of Microsoft Corp.
- PC/AT, PS/2, and VGA are trademarks of International Business Machines Corporation.

All other product names or trademarks are properties of their respective owners.

Packing List

Before you begin installing your card, please make sure that the following materials have been shipped:

- 1 Serial Port Cable with one DB-9 connector
- 1 Cable with serial port and LPT port
- 1 USB Cable
- 4 SATA Cables
- 1 DVD-ROM for manual (in PDF format) and Drivers
- 1 FSB-B75H

If any of these items should be missing or damaged, please contact your distributor or sales representative immediately.

Contents

Chapter 1 General Information

1.1 Introduction.....	1-2
1.2 Features	1-3
1.3 Specifications	1-4

Chapter 2 Quick Installation Guide

2.1 Safety Precautions	2-2
2.2 Location of Connectors and Jumpers	2-3
2.3 Mechanical Drawing	2-4
2.4 List of Jumpers	2-5
2.5 List of Connectors	2-5
2.6 Setting Jumpers	2-7
2.7 Auto Power Button (JP2).....	2-8
2.8 Clear CMOS (JP3)	2-8
2.9 Front Panel Connector (FP1)	2-8
2.10 Front Panel Connector (FP2)	2-8
2.11 Digital I/O Pin Header (DIO1).....	2-9
2.12 USB3.0 Port Pin Header (USB1, USB5).....	2-9

Chapter 3 AMI BIOS Setup

3.1 System Test and Initialization.	3-2
3.2 AMI BIOS Setup	3-3

Chapter 4 Driver Installation

4.1 Installation	4-3
------------------------	-----

Appendix A Programming The Watchdog Timer

A.1 Programming	A-2
A.2 W83627DHG Watchdog Timer Initial Program.....	A-6

Appendix B I/O Information

B.1 I/O Address Map	B-2
B.2 1 st MB Memory Address Map	B-4
B.3 IRQ Mapping Chart	B-5
B.4 DMA Channel Assignments	B-7

Appendix C Mating Connector

C.1 List of Mating Connectors and Cables.....	C-2
---	-----

Appendix D AHCI Settings

D.1 Setting AHCI	D-2
------------------------	-----

Chapter

1

**General
Information**

1.1 Introduction

AAEON, a leading Industrial PC manufacturer, announces the debut of a high performance full-size Single Board Computer, the FSB-B75H. AAEON has developed this full-size SBC based on the latest Intel® B75 chipset and the Intel® 3rd generation Core™ i7/i5/i3 LGA 1155 processor, to fulfill the increasing demands of multi-core processing.

In a PICMG 1.3 SHB Express form factor the FSB-B75H system host board takes full advantage of the Intel® B75 chipset for enhanced system performance and generous expansion capabilities. Considerable bandwidth is available with point-to-point serial PCI-Express via [x16] and [x4] interfaces. Maximizing the available PCI-Express channels offers the greatest flexibility to today's demanding I/O requirements. Two DIMM slots of dual-channel DDR3 1333/1600 sockets provide ample memory bus bandwidth for demanding applications. The FSB-B75H has been designed for users that require high performance and reliability for critical applications.

1.2 Features

- Intel® 3rd Generation Core™ i7/i5/i3 LGA 1155 Processor
- Intel® B75 Chipset
- Dual-Channel DDR3 1333/1600 DIMM Socket x 2 (Up to 16 GB)
- Intel® B75 Integrated Intel® HD Graphics
- Gigabit Ethernet x 2
- SATA 6.0 Gb/s x 1, SATA 3.0 Gb/s x 2 (Backplane x 2), CFast™ x 1, Floppy Disk Drive x 1
- USB3.0 x 4, USB2.0 x 4, COM x 2, LPT x 1
- Compliance with PICMG 1.3
- ATX 2.1 Power Requirement

1.3 Specification

System

- Form Factor PICMG 1.3 Full size SBC
- Processor Intel® 3rd Generation Core™ i7/i5/i3 LGA 1155 Processor
- System Memory 240-pin Dual-Channel DDR3 1333/1600 DIMM socket x 2, up to 16GB
- Chipset Intel® B75
- I/O Chipset Winbond W83627DHG-P
- Ethernet Realtek 8111E 10/100/1000Base-TX, RJ-45 x 2 on bracket
- BIOS AMI Plug & Play SPI BIOS-128MB ROM
- Wake on LAN Yes
- H/W Status Monitoring System temperature, voltage and cooling fan status monitoring
- Expansion Interface Follow PICMG 1.3 Regulation
- Battery Lithium battery
- Power Requirement ATX 2.1
- Board Size 13.3" x 5" (339mm x 126mm)
- Gross Weight 1.2 lb (0.5 Kg)
- Operating Temperature 32°F ~ 140°F (0°C ~ 60°C)
- Storage Temperature -4°F ~ 158°F (-20°C ~ 70°C)
- Operating Humidity 5%~90% resistive humidity,

non-condensing

Display

- Chipset Intel® B75
- Graphic Engine Integrated Intel® HD Graphics
- Resolution Up to 2048x1536 @ 75Hz for CRT
- Output Interface DVI x 1 on bracket, VGA (optional)

I/O

- Storage SATA 6.0 Gb/s x 1, SATA 3.0 Gb/s x 2
(Backplane x 2), CFast™ x 1
- Serial Port COM x 2 (box headers)
COM1: RS-232
COM2: RS-232/422/485
- PS/2 Port Keyboard/Mouse x 1 (4x2 pin header)
- USB USB3.0 x 4 (Internal 10x2 pin header x 2)
USB2.0 x 4 (onboard dual type-A
connector x 2, internal 5x2 pin header x
1) (4 USB on backplane)
- Parallel Port LPT port x 1
- Audio HDAC daughter board (optional) Mic-in/
Line-in/ Line-out
- Digital I/O 8-bit programmable (4-in/ 4-out)

Chapter

2

**Quick
Installation
Guide**

2.1 Safety Precautions

Warning!

Always completely disconnect the power cord from your board whenever you are working on it. Do not make connections while the power is on, because a sudden rush of power can damage sensitive electronic components.

Caution!

Always ground yourself to remove any static charge before touching the board. Modern electronic devices are very sensitive to static electric charges. Use a grounding wrist strap at all times. Place all electronic components on a static-dissipative surface or in a static-shielded bag when they are not in the chassis

2.2 Location of Connectors and Jumpers

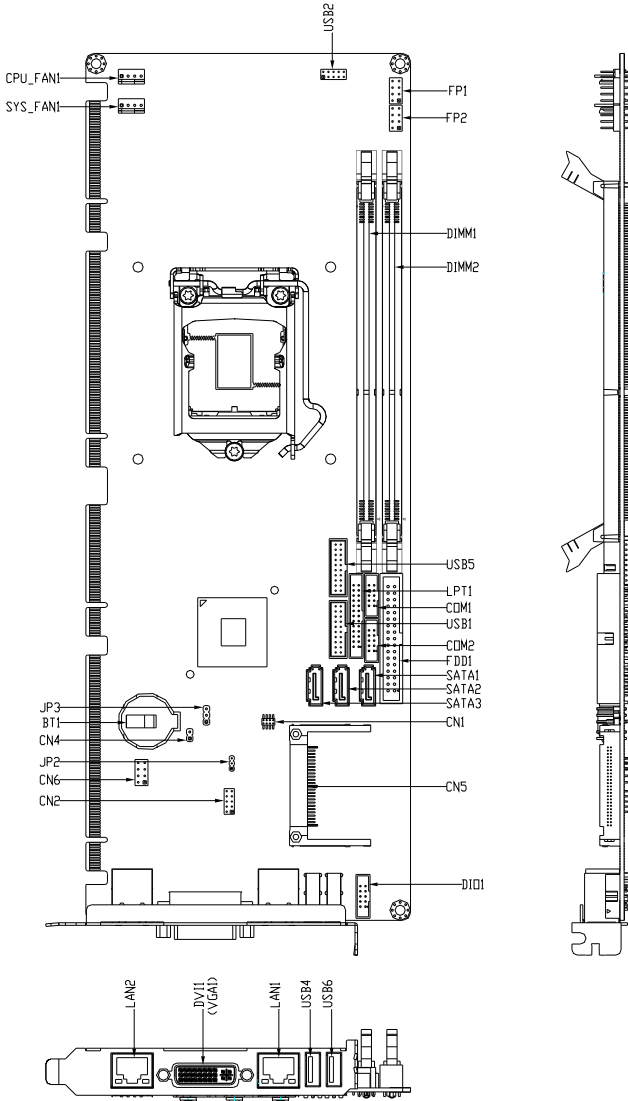

2.3 Mechanical Drawing

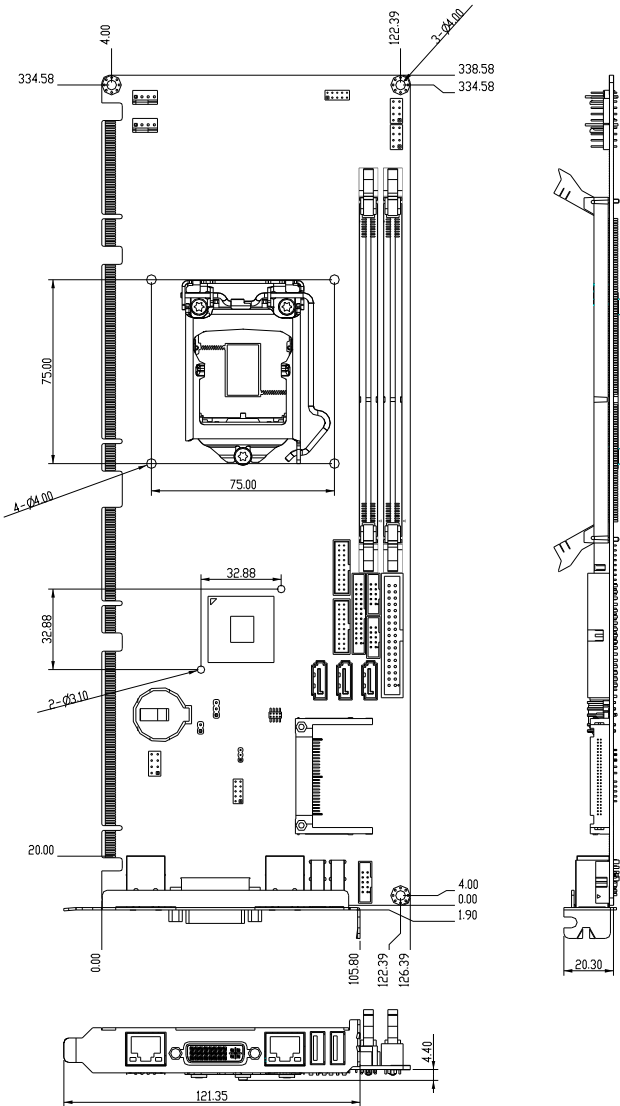

2.4 List of Jumpers

The board has a number of jumpers that allow you to configure your system to suit your application.

The table below shows the function of each of the board's jumpers:

Jumpers

Label	Function
JP2	Auto Power Button
JP3	Clear CMOS

2.5 List of Connectors

The board has a number of connectors that allow you to configure your system to suit your application. The table below shows the function of each board's connectors:

Label	Function
FP1	Front Panel Connector 1
FP2	Front Panel Connector 2
CN1	SPI Flash programmer Connector
CN2	Audio Pin Header
CN4	Case Open Connector
CN5	CFast Connector
CN6	PS2 KB/MS Pin Header
COM1	RS-232 Pin Header
COM2	RS-232/422/485 Pin Header

DIO1	Digital I/O Pin Header
FDD1	Floppy Pin Header
LPT1	Parallel Port Pin Header
USB1	USB 3.0 Pin Header
USB2	USB Pin Header
USB4	USB Connector
USB5	USB 3.0 Pin Header
USB6	USB Connector
BT1	Battery
SATA1~SATA3	SATA Connector
LAN1	10/100/1000Base-TX Ethernet Connector
LAN2	10/100/1000Base-TX Ethernet Connector
DIMM1	DDR3 DIMM Slot
DIMM2	DDR3 DIMM Slot
CPU_FAN	4 Pin Fan Connector
SYS_FAN	4 Pin Fan Connector
DVI1	DVI-I Connector

2.6 Setting Jumpers

You configure your card to match the needs of your application by setting jumpers. A jumper is the simplest kind of electric switch. It consists of two metal pins and a small metal clip (often protected by a plastic cover) that slides over the pins to connect them. To “close” a jumper you connect the pins with the clip.

To “open” a jumper you remove the clip. Sometimes a jumper will have three pins, labeled 1, 2 and 3. In this case you would connect either pins 1 and 2 or 2 and 3.

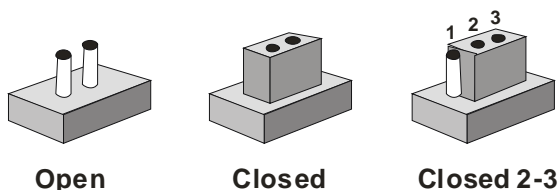

A pair of needle-nose pliers may be helpful when working with jumpers.

If you have any doubts about the best hardware configuration for your application, contact your local distributor or sales representative before you make any change.

Generally, you simply need a standard cable to make most connections.

2.7 Auto Power Button (JP2)

JP2	Function
1-2	Power ON by Button (default)
2-3	Auto Power ON

2.8 Clear CMOS (JP3)

JP3	Function
1-2	Protected (default)
2-3	Clear

2.9 Front Panel Connector (FP1)

Pin	Signal	Pin	Signal
1	Power On Button (+)	2	Reset Switch (+)
3	Power On Button (-)	4	Reset Switch (-)
5	HDD LED (+)	6	Power LED (+)
7	HDD LED (-)	8	Power LED (-)

2.10 Front Panel Connector (FP2)

Pin	Signal	Pin	Signal
1	External Speaker (+)	2	Key Board Lock (+)
3	NC	4	GND
5	Internal Buzzer (-)	6	I2C Bus SMB Clock
7	External Speaker (-)	8	I2C Bus SMB Data

Note: Closed Pin 5, 7: Internal Buzzer Enable

2.11 Digital I/O Pin Header (DIO1)

Pin	Signal	Pin	Signal
1	DIO_30	2	DIO_31
3	DIO_32	4	DIO_33
5	DIO_34	6	DIO_35
7	DIO_36	8	DIO_37
9	+5V	10	GND

2.12 USB3.0 Port Pin Header (USB1, USB5)

Pin	Signal	Pin	Signal
1	VCC	20	NC
2	USB3_RX1_DN_C	19	VCC
3	USB3_RX1_DP_C	18	USB3_RX2_DN_C
4	GND	17	USB3_RX2_DP_C
5	USB3_TX1_DN_C	16	GND
6	USB3_TX1_DP_C	15	USB3_TX2_DN_C
7	GND	14	USB3_TX2_DP_C
8	USBP_0N_C	13	GND
9	USBP_0P_C	12	USBP_1N_C
10	NC	11	USBP_1P_C

Below Table for China RoHS Requirements

产品中有毒有害物质或元素名称及含量

AAEON Main Board/ Daughter Board/ Backplane

部件名称	有毒有害物质或元素					
	铅 (Pb)	汞 (Hg)	镉 (Cd)	六价铬 (Cr(VI))	多溴联苯 (PBB)	多溴二苯醚 (PBDE)
印刷电路板 及其电子组件	×	○	○	○	○	○
外部信号 连接器及线材	×	○	○	○	○	○
<p>O: 表示该有毒有害物质在该部件所有均质材料中的含量均在 SJ/T 11363-2006 标准规定的限量要求以下。</p> <p>X: 表示该有毒有害物质至少在该部件的某一均质材料中的含量超出 SJ/T 11363-2006 标准规定的限量要求。</p> <p>备注: 此产品所标示之环保使用期限, 系指在一般正常使用状况下。</p>						

Chapter

3

**AMI
BIOS Setup**

3.1 System Test and Initialization

These routines test and initialize board hardware. If the routines encounter an error during the tests, you will either hear a few short beeps or see an error message on the screen. There are two kinds of errors: fatal and non-fatal. The system can usually continue the boot up sequence with non-fatal errors.

System configuration verification

These routines check the current system configuration stored in the CMOS memory and BIOS NVRAM. If system configuration is not found or system configuration data error is detected, system will load optimized default and re-boot with this default system configuration automatically.

There are four situations in which you will need to setup system configuration:

1. You are starting your system for the first time
2. You have changed the hardware attached to your system
3. The system configuration is reset by Clear-CMOS jumper
4. The CMOS memory has lost power and the configuration information has been erased.

The FSB-B75H CMOS memory has an integral lithium battery backup for data retention. However, you will need to replace the complete unit when it finally runs down.

3.2 AMI BIOS Setup

AMI BIOS ROM has a built-in Setup program that allows users to modify the basic system configuration. This type of information is stored in battery-backed CMOS RAM and BIOS NVRAM so that it retains the Setup information when the power is turned off.

Entering Setup

Power on the computer and press or <F2> immediately. This will allow you to enter Setup.

Main

Set the date, use tab to switch between date elements.

Advanced

Enable/disable boot option for legacy network devices.

Chipset

Host bridge parameters.

Boot

Enables/disables quiet boot option.

Security

Set setup administrator password.

Save & Exit

Exit system setup after saving the changes.

When FSB-B75H is accompanied with BP-214SH-P3E2I6 backplane in your system, please go to AAEON website www.aaeon.com to download ISA drivers from BP-214SH-P3E2I6 webpage before installation.

Setup Menu

Setup submenu: Main

Aptio Setup Utility - Copyright (C) 2012 American Megatrends, Inc.	
Main Advanced Chipset Boot Security Save & Exit	
BIOS Information FSB-B75H R1.0(FB75AM10) (08/20/2012)	Set the Date. Use Tab to switch between Date elements.
BIOS Vendor Core Version Compliance	American Megatrends 4.6.5.3 x64 UEFI 2.3; PI 1.2
System Date System Time	[Mon 08/20/2012] [14:50:51]
Access Level	Administrator
	++: Select Screen ↑↓: Select Item Enter: Select +/-: Change Opt. F1: General Help F2: Previous Values F3: Optimized Defaults F4: Save & Exit ESC: Exit
Version 2.15.1226. Copyright (C) 2012 American Megatrends, Inc.	

Setup submenu: Advanced

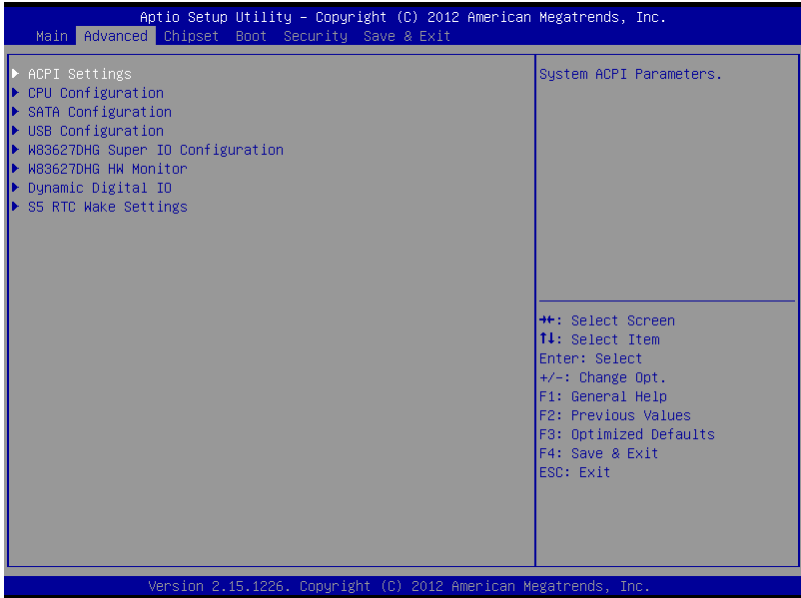

ACPI Settings

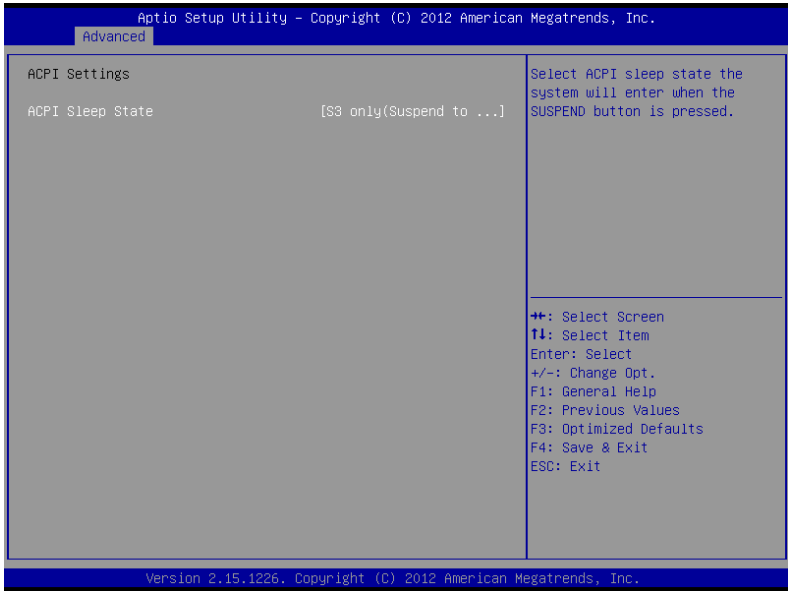

Options Summary :

ACPI Sleep State	S1 Only (CPU Stop Clock)	
	S3 Only (Suspend to RAM)	Default
Select ACPI sleep state the system will enter when the SUSPEND button is pressed.		

CPU Configuration

Aptio Setup Utility - Copyright (C) 2012 American Megatrends, Inc.

Advanced

<p>CPU Configuration</p> <p>Intel(R) Core(TM) i7-3770 CPU @ 3.40GHz</p> <p>CPU Signature 306a8</p> <p>Microcode Patch 10</p> <p>Max CPU Speed 3400 MHz</p> <p>Min CPU Speed 1600 MHz</p> <p>CPU Speed 3400 MHz</p> <p>Processor Cores 4</p> <p>Intel HT Technology Supported</p> <p>Intel VT-x Technology Supported</p> <p>Intel SMX Technology Supported</p> <p>64-bit Supported</p> <p>L1 Data Cache 32 kB x 4</p> <p>L1 Code Cache 32 kB x 4</p> <p>L2 Cache 256 kB x 4</p> <p>L3 Cache 8192 kB</p> <p>Hyper-threading [Enabled]</p> <p>Intel Virtualization Technology [Disabled]</p>	<p>Enabled for Windows XP and Linux (OS optimized for Hyper-Threading Technology) and Disabled for other OS (OS not optimized for Hyper-Threading Technology). When Disabled only one thread per enabled core is enabled.</p> <p>++: Select Screen T1: Select Item Enter: Select +/-: Change Opt. F1: General Help F2: Previous Values F3: Optimized Defaults F4: Save & Exit ESC: Exit</p>
---	--

Version 2.15.1226. Copyright (C) 2012 American Megatrends, Inc.

Options Summary :

Hyper-Threading	Disabled	Default
	Enabled	Default
Enabled for Windows XP and Linux (OS optimized for Hyper-Threading Technology) and Disabled for other OS (OS not optimized for Hyper-Threading Technology). When Disabled only one thread per enabled core is enabled.		
Intel	Disabled	Default
Virtualization Technology	Enabled	

When enabled, a VMM can utilize the additional hardware capabilities provided by Vanderpool Technology

SATA Configuration (IDE)

Aptio Setup Utility - Copyright (C) 2012 American Megatrends, Inc.

Advanced

SATA Configuration		Enable or disable SATA Device.
SATA Controller(s)	[Enabled]	
SATA Mode Selection	[IDE]	
Serial ATA Port 0	Empty	
Serial ATA Port 1	Empty	
Serial ATA Port 2	Empty	
Serial ATA Port 3	Empty	
Serial ATA Port 4	Empty	
Serial ATA Port 5	Empty	

++: Select Screen
 ↑↓: Select Item
 Enter: Select
 +/-: Change Opt.
 F1: General Help
 F2: Previous Values
 F3: Optimized Defaults
 F4: Save & Exit
 ESC: Exit

Version 2.15.1226. Copyright (C) 2012 American Megatrends, Inc.

SATA Configuration (AHCI)

Aptio Setup Utility - Copyright (C) 2012 American Megatrends, Inc.

Advanced

SATA Configuration		Determines how SATA controller(s) operate.
SATA Controller(s)	[Enabled]	
SATA Mode Selection	[AHCI]	
Serial ATA Port 0	Empty	++: Select Screen !: Select Item Enter: Select +/-: Change Opt. F1: General Help F2: Previous Values F3: Optimized Defaults F4: Save & Exit ESC: Exit
Port 0	[Enabled]	
Hot Plug	[Disabled]	
Serial ATA Port 1	Empty	
Port 1	[Enabled]	
Hot Plug	[Disabled]	
Serial ATA Port 2	Empty	
Port 2	[Enabled]	
Hot Plug	[Disabled]	
Serial ATA Port 3	Empty	
Port 3	[Enabled]	
Hot Plug	[Disabled]	
Serial ATA Port 4	Empty	
Port 4	[Enabled]	
Hot Plug	[Disabled]	
Serial ATA Port 5	Empty	
Port 5	[Enabled]	
Hot Plug	[Disabled]	

Version 2.15.1226. Copyright (C) 2012 American Megatrends, Inc.

Options summary :

SATA Controller(s)	Enabled	Default
	Disabled	
Enable or disable SATA device.		
SATA Mode Selection	IDE	Default
	AHCI	
Determines how SATA controller(s) operate.		

USB Configuration

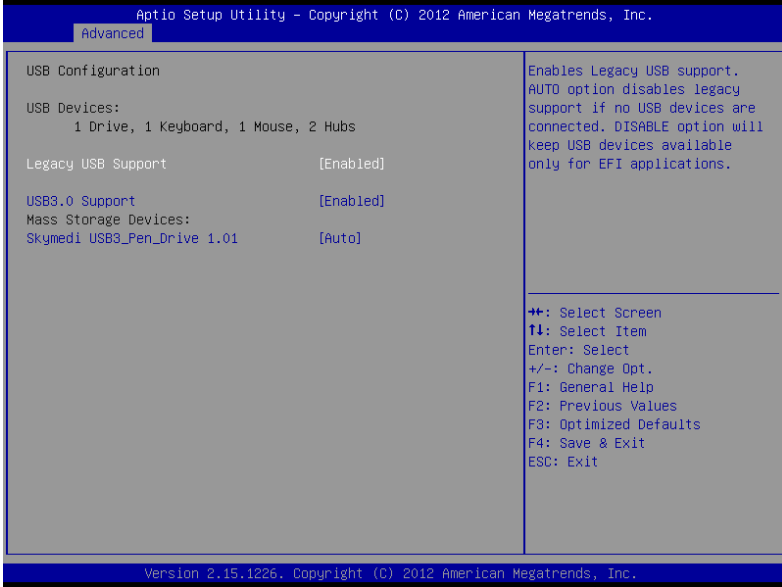

Options summary :

Legacy USB Support	Enabled	Default
	Disabled	
	Auto	
Enable Legacy USB support. Auto option disables legacy support if no USB devices are connected. DISABLE option will keep USB devices available only for EFI applications.		
USB3.0 Support	Enabled	Default
	Disabled	
Enable/Disable USB3.0 (XHCI) Controller support.		

W83627DHG Super IO Configuration

Aptio Setup Utility - Copyright (C) 2012 American Megatrends, Inc.

Advanced

<p>W83627DHG Super IO Configuration</p> <p>W83627DHG Super IO Chip W83627DHG</p> <p>▶ Floppy Disk Controller Configuration</p> <p>▶ Serial Port 1 Configuration</p> <p>▶ Serial Port 2 Configuration</p> <p>▶ Parallel Port Configuration</p> <p>Restore AC Power Loss [Last State]</p>	<p>Set Parameters of Floppy Disk Controller (FDC)</p>
	<p>++: Select Screen</p> <p>T1: Select Item</p> <p>Enter: Select</p> <p>+/-: Change Opt.</p> <p>F1: General Help</p> <p>F2: Previous Values</p> <p>F3: Optimized Defaults</p> <p>F4: Save & Exit</p> <p>ESC: Exit</p>

Version 2.15.1226, Copyright (C) 2012 American Megatrends, Inc.

Options Summary :

Floppy Disk Controller Configuration	Set Parameters of Floppy Disk Controller (FDC)
Serial Port 1 Configuration	Set Parameters of Serial Port 1 (COMA)
Serial Port 2 Configuration	Set Parameters of Serial Port 2 (COMB)

Parallel Port Configuration	Set Parameters of Parallel Port (LPT/LPTE)	
Restore AC Power Loss	Always OFF	
	Always ON	
	Last State	Default
Select AC power state when power is re-applied after a power failure.		

Floppy Disk Controller Configuration

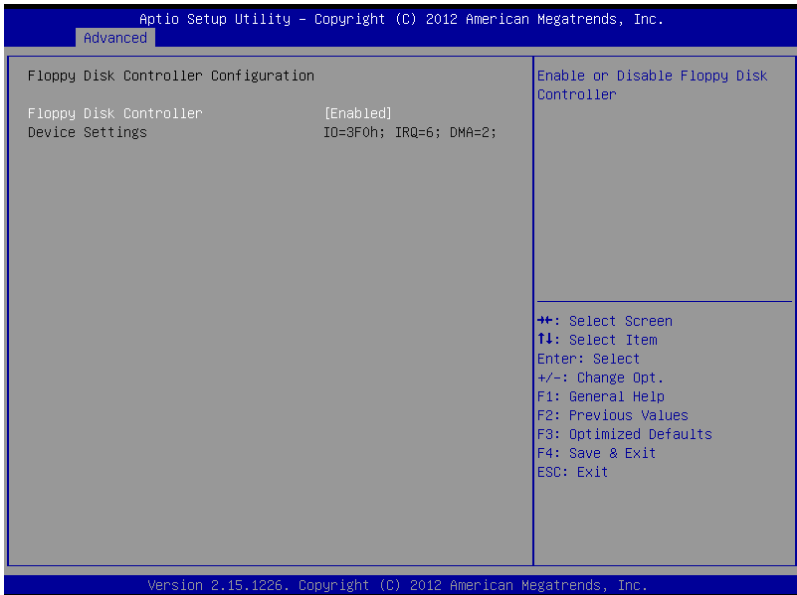

Options Summary :

Floppy Disk Controller	Disabled	
	Enabled	Default
Enable or Disable Floppy Disk Controller		

Serial Port 1 Configuration

Aptio Setup Utility - Copyright (C) 2012 American Megatrends, Inc.

Advanced

Serial Port 1 Configuration		Enable or Disable Serial Port (COM)
Serial Port	[Enabled]	
Device Settings	IO=3F8h; IRQ=4;	
Change Settings	[Auto]	
		++: Select Screen ↑↓: Select Item Enter: Select +/-: Change Opt. F1: General Help F2: Previous Values F3: Optimized Defaults F4: Save & Exit ESC: Exit
Version 2.15.1226. Copyright (C) 2012 American Megatrends, Inc.		

Options Summary :

Serial Port	Disabled	
	Enabled	Default
Enable or Disable Serial Port (COM)		
Change Settings	Auto	Default

Options Summary :

Parallel Port	Disabled	
	Enabled	Default
Enable or Disable Parallel Port (LPT/LPTE)		
Change Settings	Auto	Default
	IO=378h; IRQ=5	
	IO=378h; IRQ=5,6,7,10,11,12	
	IO=278h; IRQ=5,6,7,10,11,12	
	IO=3BCh; IRQ=5,6,7,10,11,12	
Select an optimal setting for Super IO device.		
Device Mode	STD Printer Mode	Default
	SPP Mode	
	EPP-1.9 and SPP Mode	
	EPP-1.7 and SPP Mode	
	ECP Mode	
	ECP and EPP 1.9 Mode	
	ECP and EPP 1.7 Mode	

Change the Printer Port mode.

W83627DHG HW Monitor

Aptio Setup Utility - Copyright (C) 2012 American Megatrends, Inc.

Advanced

<p>Pc Health Status</p> <p>Smart Fan Function [Enabled]</p> <p>▶ Smart Fan Mode Configuration</p> <p>SYSTIN temperature : +36 ℃ CPU Temperature : +53 ℃</p> <p>System Fan Speed : N/A CPU Fan Speed : 1814 RPM</p> <p>VDDRE : +0.984 V +12V : +12.032 V +3.3V : +3.440 V V_SM : +1.520 V AVCC : +3.424 V VDD3V : +3.424 V VSB3 : +3.424 V VBAT : +3.136 V</p>	<p>Enable or Disable Smart Fan</p> <hr/> <p>↔: Select Screen ↑↓: Select Item Enter: Select +/-: Change Opt. F1: General Help F2: Previous Values F3: Optimized Defaults F4: Save & Exit ESC: Exit</p>
---	---

Version 2.15.1226. Copyright (C) 2012 American Megatrends, Inc.

Options Summary :

Smart Fan Function	Disabled	
	Enabled	Default
Enable or Disable Smart Fan		
Smart Fan Mode Configuration	Smart Fan Mode Select	

Smart Fan Mode Configuration

Aptio Setup Utility - Copyright (C) 2012 American Megatrends, Inc.

Advanced

Smart Fan Mode Configuration SYS Smart Fan Mode [Manual Mode] SYSFAN PWM/DC Voltage Output 255 CPU Smart Fan 0 Mode [Manual Mode] CPUFAN0 PWM/DC Voltage Output 255 FAN Step down Time 10 FAN Step up Time 10	SYS Smart Fan Mode Select ⇄: Select Screen ↓: Select Item Enter: Select +/-: Change Opt. F1: General Help F2: Previous Values F3: Optimized Defaults F4: Save & Exit ESC: Exit
---	---

Version 2.15.1226. Copyright (C) 2012 American Megatrends, Inc.

Options Summary :

SYS Smart Fan Mode	Manual Mode	Default
	Thermal	
	Cruise Mode	
	Fan Speed	
	Cruise Mode	
SYS Smart Fan Mode Select		
SYSFAN PWM/DC Voltage Output	0~255	Default : 255
Input expect PWM Output Value(Range:0 – 255)		

CPU Smart Fan 0 Mode	Manual Mode	Default
	Thermal Cruise Mode	
	Fan Speed Cruise Mode	
	SMART FAN III Mode	
	CPU Smart Fan 0 Mode Select	
CPUFAN0 PWM/DC Voltage Output	0~255	Default : 255
Input expect PWM Output Value(Range: 0 – 255) It's also the Fan Output initial value in Smart Fan III Mode		
FAN Step down Time	Time	Default : 10
FAN Step down time value, unit is 0.1, default is 1 second		
FAN Step up Time	Time	Default: 10
FAN Step up time		

Dynamic Digital IO(Default Disabled)

Aptio Setup Utility - Copyright (C) 2012 American Megatrends, Inc.	
Advanced	
Dynamic Digital IO	Enable or Disable Dynamic Digital IO support
Dynamic Digital IO Support [Disabled]	
	++ : Select Screen T1 : Select Item Enter: Select +/-: Change Opt. F1: General Help F2: Previous Values F3: Optimized Defaults F4: Save & Exit ESC: Exit
Version 2.15.1226. Copyright (C) 2012 American Megatrends, Inc.	

Dynamic Digital IO(Enabled)

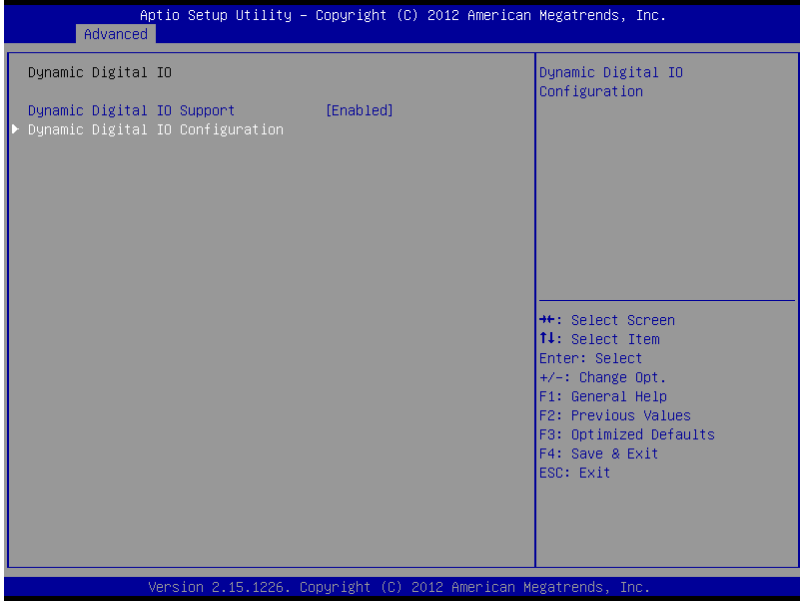

Options Summary :

Dynamic Digital IO Configuration	Dynamic Digital IO Configuration
----------------------------------	----------------------------------

Dynamic Digital IO Configuration

Aptio Setup Utility - Copyright (C) 2012 American Megatrends, Inc.

Advanced

DIO0 Direction	[Input]	Set Digital IO as Input or Output
DIO1 Direction	[Input]	
DIO2 Direction	[Input]	
DIO3 Direction	[Input]	
DIO4 Direction	[Output]	++: Select Screen ↑: Select Item Enter: Select +/-: Change Opt. F1: General Help F2: Previous Values F3: Optimized Defaults F4: Save & Exit ESC: Exit
Output Level	[Hi]	
DIO5 Direction	[Output]	
Output Level	[Hi]	
DIO6 Direction	[Output]	
Output Level	[Hi]	
DIO7 Direction	[Output]	
Output Level	[Hi]	

Version 2.15.1226. Copyright (C) 2012 American Megatrends, Inc.

Options Summary :

DIO0 Direction	Input	Default
	Output	
Set Digital IO as Input or Output		
DIO1 Direction	Input	Default
	Output	
Set Digital IO as Input or Output		
DIO2 Direction	Input	Default
	Output	
Set Digital IO as Input or Output		

DIO3 Direction	Input	Default
	Output	
Set Digital IO as Input or Output		
DIO4 Direction	Input	
	Output	Default
Set Digital IO as Input or Output		
DIO5 Direction	Input	
	Output	Default
Set Digital IO as Input or Output		
DIO6 Direction	Input	
	Output	Default
Set Digital IO as Input or Output		
DIO7 Direction	Input	
	Output	Default
Set Digital IO as Input or Output		
Output Level	Hi	Default
	Low	
Set Digital IO Output as Hi or Low		

S5 RTC Wake Settings

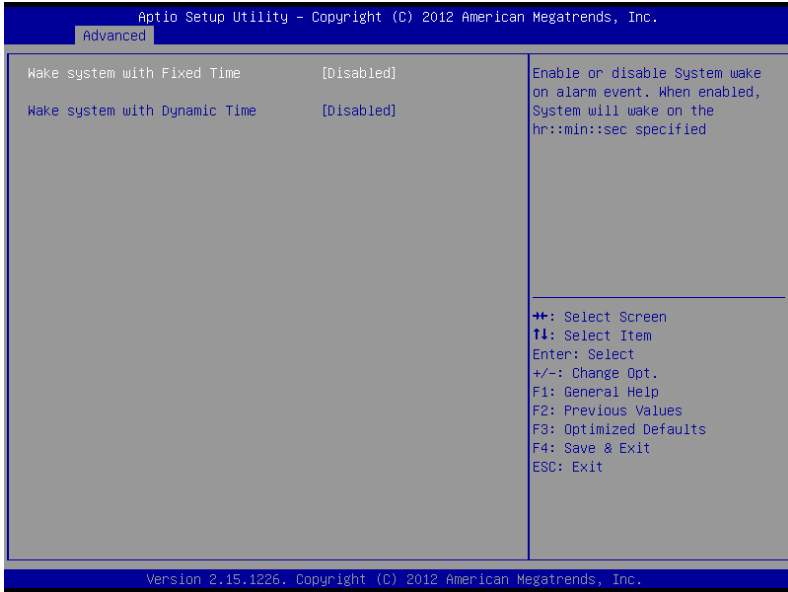

Options Summary :

Wake system with Fixed Time	Disabled	Default
	Enabled	
Enable or disable System wake on alarm event. When enabled, System will wake on the hr::min::sec specified		
Wake system with Dynamic Time	Disabled	Default
	Enabled	
Enable or disable System wake on alarm event. When enabled, System will wake on the hr::min::sec specified		

Setup submenu: Chipset

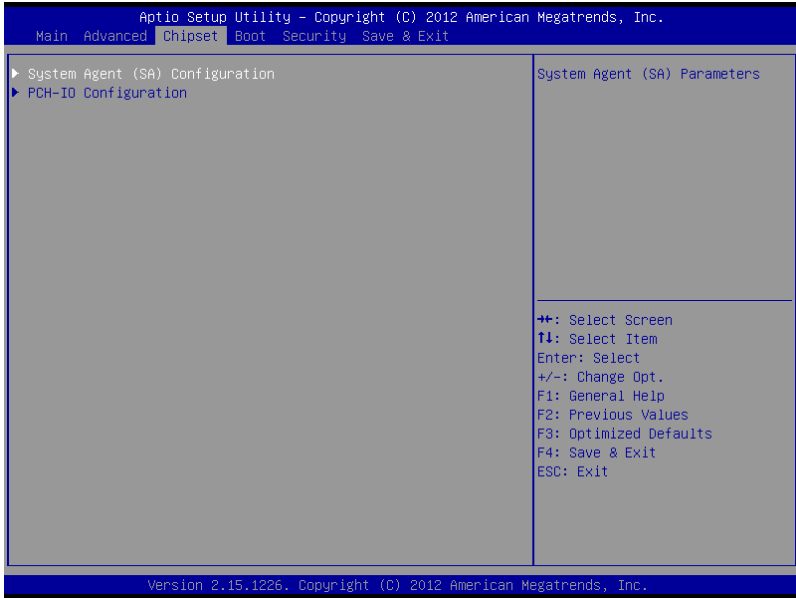

Options Summary :

System Agent (SA) Configuration	System Agent (SA) Parameters
PCH-IO Configuration	PCH Parameters

System Agent (SA) Configuration

Aptio Setup Utility - Copyright (C) 2012 American Megatrends, Inc.

Chipset

<p>Memory Information</p> <p>Memory Frequency 1333 Mhz</p> <p>Total Memory 4096 MB (DDR3)</p> <p>DIMM#0 Not Present</p> <p>DIMM#2 4096 MB (DDR3)</p> <p>PEG0 - Gen X [Auto]</p> <p>▶ Graphics Configuration</p>	<p>Configure PEG0 B0:D1:F0 Gen1-Gen3</p> <hr/> <p> ⇐+: Select Screen ↑↓: Select Item Enter: Select +/-: Change Opt. F1: General Help F2: Previous Values F3: Optimized Defaults F4: Save & Exit ESC: Exit </p>
---	--

Version 2.15.1226. Copyright (C) 2012 American Megatrends, Inc.

Options Summary :

Graphics Configuration	Configure PEG0 B0:D1:F0 Fen1-Gen3
------------------------	-----------------------------------

Graphics Configuration

Aptio Setup Utility - Copyright (C) 2012 American Megatrends, Inc.

Chipset

<p>Graphics Configuration</p> <p>Primary Display [Auto] Internal Graphics [Auto] DVMT Pre-Allocated [64M] DVMT Total Gfx Mem [MAX]</p> <p>Primary IGFX Boot Display [VBIOS Default]</p>	<p>Select which of IGFX/PEG/PCI Graphics device should be Primary Display Or select SG for Switchable Gfx.</p> <hr/> <p> ++: Select Screen Tl: Select Item Enter: Select +/-: Change Opt. F1: General Help F2: Previous Values F3: Optimized Defaults F4: Save & Exit ESC: Exit </p>
--	--

Version 2.15.1226. Copyright (C) 2012 American Megatrends, Inc.

Options Summary :

Primary Display	Auto	Default
	IGFX	
	PEG	
	PCI	
Select which of IGFX/PEG/PCI Graphics device should be Primary Display Or select SG for Switchable Gfx.		
Internal Graphics	Auto	

	Disabled	
	Enabled	
Keep IGD enabled based on the setup options.		
DVMT Pre-Allocated	32M	
	64M	Default
	96M	
	128M	
	160M	
	192M	
	224M	
	256M	
	288M	
	320M	
	352M	
	384M	
	416M	
448M		

	480M	
	512M	
	1024M	
Select DVMT 5.0 Pre-Allocated (Fixed) Graphics Memory size used by the Internal Graphics Device.		
DVMT Total Gfx Mem	128M	
	256M	
	MAX	Default
Select DVMT5.0 Total Graphic Memory size used by the Internal Graphics Device.		
Primary IGFX Boot Display	VBIOS	Default
	Default	
	CRT	
	DVI	
<p>Select the Video Device which will be activated during POST. This has no effect if external graphics present.</p> <p>Secondary boot display selection will appear based on your selection.</p> <p>VGA modes will be supported only on primary display</p>		

PCH-IO Configuration

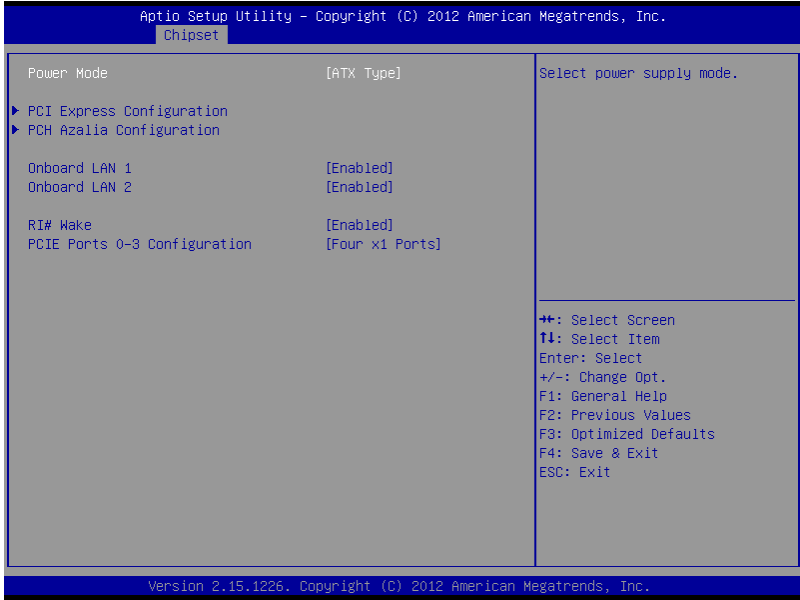

Options Summary :

Power Mode	ATX Type	Default
	AT Type	
Select power supply mode.		
PCI Express Configuration	PCI Express Configuration settings	
PCH Azalia Configuration	PCH Azalia Configuration settings.	
Onboard LAN 1	Disabled	Default
	Enabled	

En/Disable Onboard LAN 1 (RTL8111E)		
Onboard LAN 2	Disabled	
	Enabled	Default
En/Disable Onboard LAN 2 (RTL8111E)		
RI# Wake	Disabled	
	Enabled	Default
<p>For En/Disable Ring In wake up function.</p> <p>Attention please, when this function is enabled, some devices which connect to Serial Port may cause the system auto wake up from sleep mode.</p>		
PCIE PORTS 0-3 Configuration	Four x1 Ports	Default
	One x4 Port	
<p>To configure PCI-E Port 0-3 of PCH as four x1 slots or one x4 slot.</p> <p>Step: 1. Change the option and save, system will issue special beep during next boot.</p> <p>2. When user hear the special beep, please shutdown system and remove AC power cord.</p> <p>3. Plug-in AC power cord and power on the system will set to the mode that user</p>		

PCI Express Configuration

Aptio Setup Utility - Copyright (C) 2012 American Megatrends, Inc.

Chipset

PCI Express Configuration		Control the PCI Express Root Port.
PCI Express Root Port 1	[Enabled]	++: Select Screen ↑: Select Item Enter: Select +/-: Change Opt. F1: General Help F2: Previous Values F3: Optimized Defaults F4: Save & Exit ESC: Exit
PCIe Speed	[Auto]	
PCI Express Root Port 2	[Enabled]	
PCIe Speed	[Auto]	
PCI Express Root Port 3	[Enabled]	
PCIe Speed	[Auto]	
PCI Express Root Port 4	[Enabled]	
PCIe Speed	[Auto]	

Version 2.15.1226. Copyright (C) 2012 American Megatrends, Inc.

Options Summary :

PCI Express Root	Disabled	
Port 1	Enabled	Default
Control the PCI Express Root Port.		
PCIe Speed	Auto	
	Gen 1	
	Gen 2	
Select PCI Express port speed.		
PCI Express Root	Disabled	
Port 2	Enabled	Default

Control the PCI Express Root Port.		
PCIe Speed	Auto	
	Gen 1	
	Gen 2	
Select PCI Express port speed.		
PCI Express Root Port 3	Disabled	
	Enabled	Default
Control the PCI Express Root Port.		
PCIe Speed	Auto	
	Gen 1	
	Gen 2	
Select PCI Express port speed.		
PCI Express Root Port 4	Disabled	
	Enabled	Default
Control the PCI Express Root Port.		
PCIe Speed	Auto	
	Gen 1	
	Gen 2	
Select PCI Express port speed.		

PCH Azalia Configuration

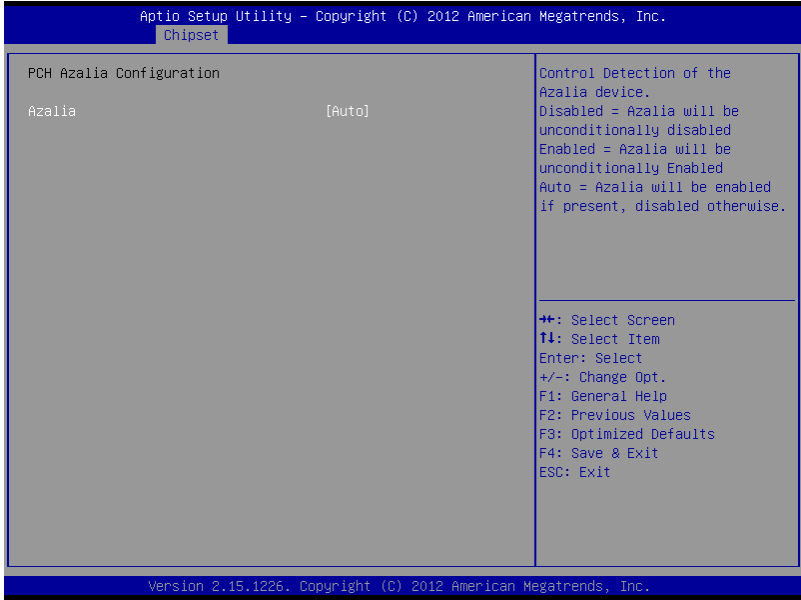

Options Summary :

Azalia	Disabled	
	Enabled	
	Auto	Default
<p>Control Detection of the Azalia device.</p> <p>Disabled = Azalia will be unconditionally disabled</p> <p>Enabled = Azalia will be unconditionally Enabled</p> <p>Auto = Azalia will be enabled if present, disabled otherwise.</p>		

Setup submenu: Boot

Boot Option Priorities

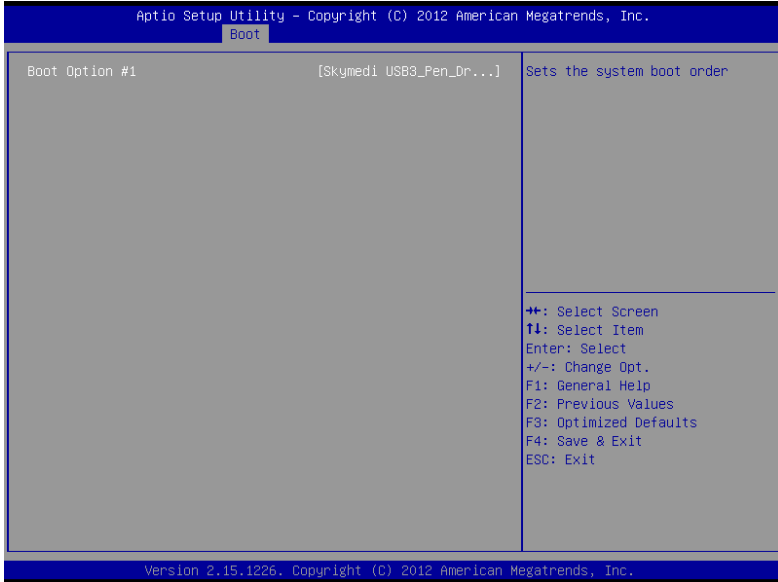

Options Summary :

Boot Option #X	Your device	
	Your device	
Sets the system boot order		

Setup submenu: Security

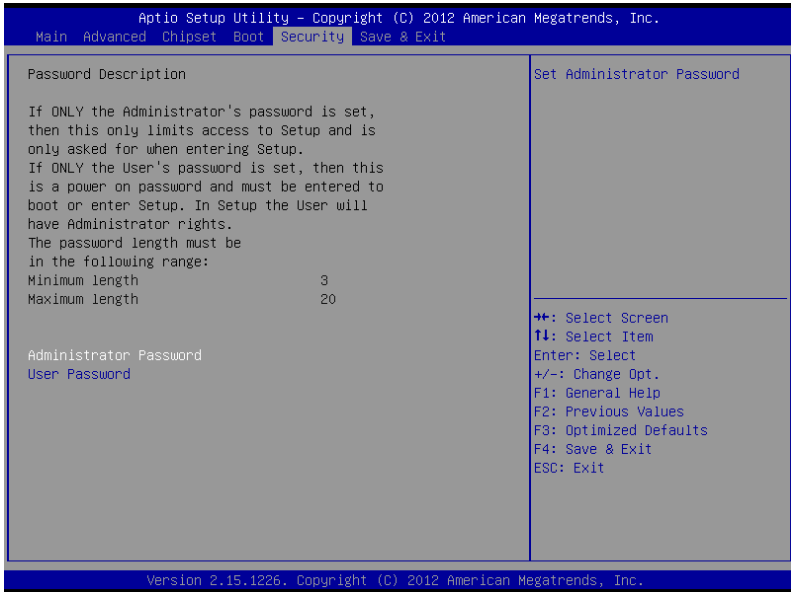

Change User/Supervisor Password

You can install a Supervisor password, and if you install a supervisor password, you can then install a user password. A user password does not provide access to many of the features in the Setup utility.

If you highlight these items and press Enter, a dialog box appears which lets you enter a password. You can enter no more than six letters or numbers. Press Enter after you have typed in the password. A second dialog box asks you to retype the password for confirmation. Press Enter after you have retyped it correctly. The password is required at boot time, or when the user enters the

Setup utility.

Removing the Password

Highlight this item and type in the current password. At the next dialog box press Enter to disable password protection.

Setup submenu: Exit

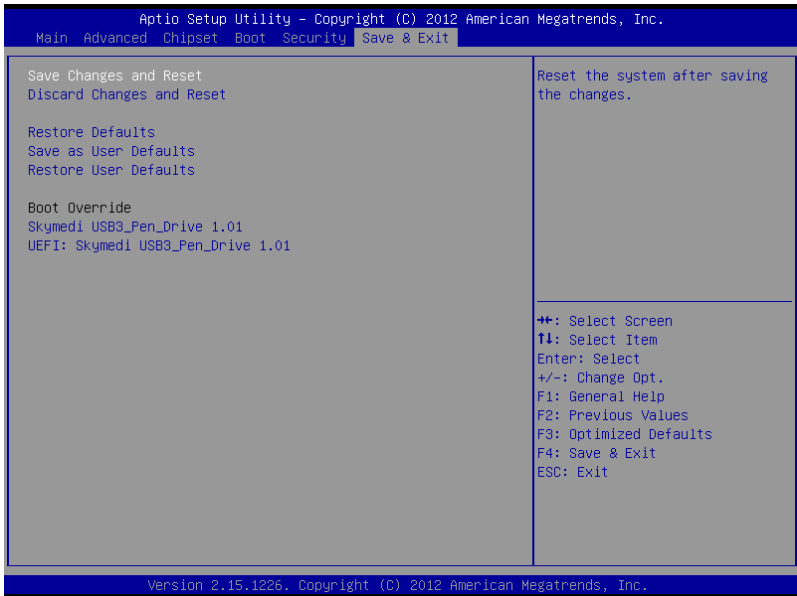

Chapter

4

**Driver
Installation**

The FSB-B75H comes with a DVD-ROM that contains all drivers and utilities that meet your needs.

Follow the sequence below to install the drivers:

- Step 1 – Install Chipset Driver
- Step 2 – Install VGA Driver
- Step 3 – Install LAN Driver
- Step 4 – Install Audio Driver
- Step 5 – Install USB3.0 Driver
- Step 6 – Install AHCI Driver
- Step 7 – Install ME Driver

4.1 Installation:

Insert the FSB-B75H DVD-ROM into the DVD-ROM Drive. And install the drivers from Step 1 to Step 7 in order.

Step 1 – Install Chipset Driver

1. Click on the **Step 1-Chipset** folder and double click on the ***infinst_autol_9.3.0.1021.exe*** file
2. Follow the instructions that the window shows
3. The system will help you install the driver automatically

Step 2 – Install VGA Driver

1. Click on the **Step 2-VGA** folder and select the OS folder your system is
2. Double click on the **Setup.exe** file located in each OS folder
3. Follow the instructions that the window shows
4. The system will help you install the driver automatically

Step 3 – Install LAN Driver

1. Click on the **Step 3-LAN** folder and select the OS folder your system is
2. Double click on the **setup.exe** file located in each OS folder
3. Follow the instructions that the window shows
4. The system will help you install the driver automatically

Step 4 – Install Audio Driver

1. Click on the **Step 4-Audio** folder and select the OS folder your system is
2. Double click on the **.exe** file located in each OS folder
3. Follow the instructions that the window shows
4. The system will help you install the driver automatically

Step 5 – Install USB3.0 Driver

1. Click on the **Step 5-USB3.0** folder and double click on the **Setup.exe** file
2. Follow the instructions that the window shows
3. The system will help you install the driver automatically

Step 6 – Install AHCI Driver

Please refer to the Appendix D AHCI Settings

Step 7 – Install ME Driver

1. Click on the **Step 7-ME** folder and double click on the **setup.exe** file
2. Follow the instructions that the window shows
3. The system will help you install the driver automatically

Appendix

A

Programming the Watchdog Timer

A.1 Programming

FSB-B75H utilizes W83627DHG chipset as its watchdog timer controller.

Below are the procedures to complete its configuration and the AAEON initial watchdog timer program is also attached based on which you can develop customized program to fit your application.

Configuring Sequence Description

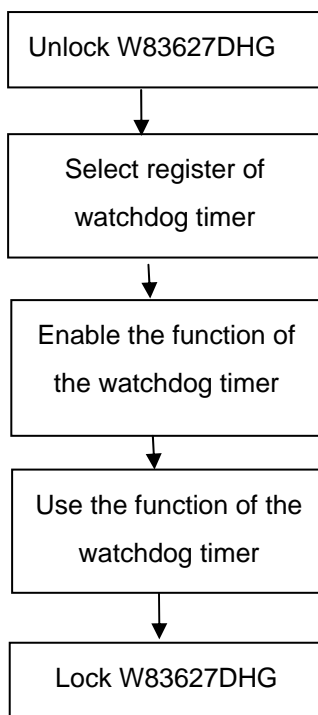

There are three steps to complete the configuration setup:

- (1) Enter the W83627DHG config Mode
- (2) Modify the data of configuration registers

- (3) Exit the W83627DHG config Mode. Undesired result may occur if the config Mode is not exited normally.

(1) Enter the W83627DHG config Mode

To enter the W83627DHG config Mode, two special I/O write operations are to be performed during Wait for Key state. To ensure the initial state of the key-check logic, it is necessary to perform two write operations to the Special Address port (2EH). The different enter keys are provided to select configuration ports (2EH/2Fh) of the next step.

	Address Port	Data Port
87h,87h:	2Eh	2Fh

(2) Modify the Data of the Registers

All configuration registers can be accessed after entering the config Mode. Before accessing a selected register, the content of Index 07h must be changed to the LDN to which the register belongs, except some Global registers.

(3) Exit the W83627DHG config Mode

The exit key is provided to select configuration ports (2EH/2Fh) of the next step.

	Address Port	Data Port
0aah:	2Eh	2Fh

CR 30h. (Default 02h)

BIT	READ/WRITE	DESCRIPTION
7~3	Reserved.	
2	R/W	0: GPIO6 is inactive. 1: GPIO6 is active.

1	R/W	0: GPIO5 is inactive. 1: GPIO5 is active.
0	R/W	0: WDTO# and PLED are inactive. 1: WDTO# and PLED are inactive.

CR F5h. (WDTO# and KBC P20 Control Mode Register; Default 00h)

BIT	READ/WRITE	DESCRIPTION
7~5	Reserved.	
4	R/W	1000 time faster in WDTO# count mode. 0: Disable. 1: Enable. (If bit-3 is Second Mode, the count mode is 1/1000 Sec.) (If bit-3 is Minute Mode, the count mode is 1/1000 Min.)
3	R/W	Select WDTO# count mode. 0: Second Mode. 1: Minute Mode.
2	R/W	Enable the rising edge of KBC reset (P20) to issue time-out event. 0: Disable. 1: Enable.
1	R/W	Disable/ Enable the WDTO# output low pulse to the KBRST# pin (PIN60) 0: Disable. 1: Enable.
0	Reserved.	

CR F6h. (WDTO# Counter Register; Default 00h)

BIT	READ/WRITE	DESCRIPTION
7~0	R/W	Watch Dog Timer Time-out value. Writing a non-zero value to this register causes the counter to load the value to Watch Dog Counter and start counting down. If bits 7 and 6 of CR F7h are set, any Mouse Interrupt or Keyboard Interrupt event will also cause the reload of previously-loaded non-zero value to Watch Dog Counter and start counting down. Reading this register returns current value in Watch Dog Counter instead of Watch Dog Timer Time-out value. 00h: Time-out Disable

		01h: Time-out occurs after 1 second/minute 02h: Time-out occurs after 2 second/minutes 03h: Time-out occurs after 3 second/minutes FFh: Time-out occurs after 255 second/minutes
--	--	--

CR F7h. (WDTO# Control & Status Register; Default 00h)

BIT	READ/WRITE	DESCRIPTION
7	R/W	Mouse interrupt reset watch-dog timer enable 0: Watchdog timer is not affected by mouse interrupt. 1: Watchdog timer is reset by mouse interrupt.
6	R/W	Keyboard interrupt reset watch-dog timer enable 0: Watchdog timer is not affected by keyboard interrupt. 1: Watchdog timer is reset by keyboard interrupt.
5	Write "1" Only	Trigger WDTO# event. This bit is self-clearing.
4	R/W Write "0" Clear	WDTO# status bit 0: Watchdog timer is running. 1: Watchdog timer issue time-out event.
3~0	R/W	These bits select IRQ resource for WDTO#. (02h for SMI# event.)

A.2 W83627DHG Watchdog Timer Initial Program

	LDN	Register	Bit	Description
WDT Timer value	0x07	0xF6	Bit [7-0]	00h: Time-out Disable 01h: Time-out occurs after 1 minute only. 02h: Time-out occurs after 2 second/minutes 03h: Time-out occurs after 3 second/minutes FFh: Time-out occurs after 255 second/minutes (The deviation is approx 1 second.)
WDT Unit	0x07	0xF5	Bit3	Select WDTO# count mode. 0: Second Mode. 1: Minute Mode.

```
#include <stdio.h>
#include <conio.h>
```

```
#define SIOIndex    0x2E //Modify for project support 2E/4E
#define SIOData     0x2F //Modify for project support 2F/4F
#define void AaeonWDTConfig(void);
#define void AaeonWDTEnable(Byte Timer, boolean Unit);
```

```
void Main(){
    // Procedure : AaeonWDTConfig
    // This procdure will enable the WDT counting.
    AaeonWDTConfig (void);

    // Procedure : AaeonWDTEnable
    // (byte)Timer      : Time of WDT timer.(0x00~0xFF)
    // (boolean)Unit    : Select time unit(0: second, 1: minute).
    AaeonWDTEnable(Byte Timer, boolean Unit);
}
```

```
// Procedure : AaeonWDTConfig
void AaeonWDTConfig (void){
    Byte val;
    //Super I/O Entry Key
    outputb(SIOIndex,0x87);
    outputb(SIOIndex,0x87);

    //Setting WDT Pin.
    outputb(SIOIndex,0x2D);
    val = inportb((SIOData);
    outputb(SIOIndex,0x2D);
    outputb(SIOData,val & 0xFE);

    // Enable WatchDog function
    outputb(SIOIndex,0x07);
    outputb(SIOData,0x08);
    outputb(SIOIndex,0x30);
    outputb(SIOData, 0x01);
}
```

**

// Procedure :

```
void AaeonWDTEnable (Byte Timer, boolean Unit){
```

```
    Byte val;
```

```
    //Super I/O Entry Key
```

```
    outputb(SIOIndex,0x87);
```

```
    outputb(SIOIndex,0x87);
```

```
    // Select Logic Device Number Register
```

```
    outputb(SIOIndex,0x07);
```

```
    outputb(SIOData,0x08);
```

```
    // Setting WDT Operation Mode
```

```
    outputb(SIOIndex,0xF5);
```

```
    val = inportb((SIOData);
```

```
    outputb(SIOIndex,0xF5);
```

```
    outputb(SIOData, val | Unit << 3 );
```

```
    // Setting WDT Counter
```

```
    outputb(SIOIndex,0xF6);
```

```
    outputb(SIOData,Timer);
```

```
}
```

Appendix

B

I/O Information

B.1 I/O Address Map

Input/output (IO)	
[00000000 - 0000001F]	Direct memory access controller
[00000000 - 00000CF7]	PCI bus
[00000010 - 0000001F]	Motherboard resources
[00000020 - 00000021]	Programmable interrupt controller
[00000022 - 0000003F]	Motherboard resources
[00000024 - 00000025]	Programmable interrupt controller
[00000028 - 00000029]	Programmable interrupt controller
[0000002C - 0000002D]	Programmable interrupt controller
[0000002E - 0000002F]	Motherboard resources
[00000030 - 00000031]	Programmable interrupt controller
[00000034 - 00000035]	Programmable interrupt controller
[00000038 - 00000039]	Programmable interrupt controller
[0000003C - 0000003D]	Programmable interrupt controller
[00000040 - 00000043]	System timer
[00000044 - 0000005F]	Motherboard resources
[0000004E - 0000004F]	Motherboard resources
[00000050 - 00000053]	System timer
[00000061 - 00000061]	Motherboard resources
[00000062 - 00000063]	Motherboard resources
[00000063 - 00000063]	Motherboard resources
[00000065 - 00000065]	Motherboard resources
[00000065 - 0000006F]	Motherboard resources
[00000067 - 00000067]	Motherboard resources
[00000070 - 00000070]	Motherboard resources
[00000070 - 00000077]	System CMOS/real time clock
[00000072 - 0000007F]	Motherboard resources
[00000080 - 00000080]	Motherboard resources
[00000080 - 00000080]	Motherboard resources
[00000081 - 00000091]	Direct memory access controller
[00000084 - 00000086]	Motherboard resources
[00000088 - 00000088]	Motherboard resources
[0000008C - 0000008E]	Motherboard resources
[00000090 - 0000009F]	Motherboard resources
[00000092 - 00000092]	Motherboard resources
[00000093 - 0000009F]	Direct memory access controller
[000000A0 - 000000A1]	Programmable interrupt controller
[000000A2 - 000000BF]	Motherboard resources
[000000A4 - 000000A5]	Programmable interrupt controller
[000000A8 - 000000A9]	Programmable interrupt controller
[000000AC - 000000AD]	Programmable interrupt controller























































[000000B0 - 000000B1]	Programmable interrupt controller
[000000B2 - 000000B3]	Motherboard resources
[000000B4 - 000000B5]	Programmable interrupt controller
[000000B8 - 000000B9]	Programmable interrupt controller
[000000BC - 000000BD]	Programmable interrupt controller
[000000C0 - 000000DF]	Direct memory access controller
[000000E0 - 000000EF]	Motherboard resources
[000000F0 - 000000FF]	Numeric data processor
[000002F8 - 000002FF]	Communications Port (COM2)
[00000378 - 0000037F]	Printer Port (LPT1)
[000003B0 - 000003BB]	Intel(R) HD Graphics 4000
[000003C0 - 000003DF]	Intel(R) HD Graphics 4000
[000003F0 - 000003F5]	Standard floppy disk controller
[000003F7 - 000003F7]	Standard floppy disk controller
[000003F8 - 000003FF]	Communications Port (COM1)
[00000400 - 00000453]	Motherboard resources
[00000454 - 00000457]	Motherboard resources
[00000458 - 0000047F]	Motherboard resources
[000004D0 - 000004D1]	Motherboard resources
[000004D0 - 000004D1]	Programmable interrupt controller
[00000500 - 0000057F]	Motherboard resources
[00000680 - 0000069F]	Motherboard resources
[00000A00 - 00000A0F]	Motherboard resources
[00000D00 - 0000FFFF]	PCI bus
[00001000 - 0000100F]	Motherboard resources
[0000164E - 0000164F]	Motherboard resources
[0000D000 - 0000D0FF]	Realtek PCIe GBE Family Controller
[0000D000 - 0000DFFF]	Intel(R) 7 Series/C216 Chipset Family PCI Express Root Port 8 - 1E1E
[0000E000 - 0000E0FF]	Realtek PCIe GBE Family Controller #2
[0000E000 - 0000EFFF]	Intel(R) 7 Series/C216 Chipset Family PCI Express Root Port 7 - 1E1C
[0000F000 - 0000F03F]	Intel(R) HD Graphics 4000
[0000F040 - 0000F05F]	Intel(R) 7 Series/C216 Chipset Family SMBus Host Controller - 1E22
[0000F060 - 0000F07F]	Intel(R) 7 Series/C216 Chipset Family SATA AHCI Controller - 1E02
[0000F080 - 0000F083]	Intel(R) 7 Series/C216 Chipset Family SATA AHCI Controller - 1E02
[0000F090 - 0000F097]	Intel(R) 7 Series/C216 Chipset Family SATA AHCI Controller - 1E02
[0000F0A0 - 0000F0A3]	Intel(R) 7 Series/C216 Chipset Family SATA AHCI Controller - 1E02
[0000F0B0 - 0000F0B7]	Intel(R) 7 Series/C216 Chipset Family SATA AHCI Controller - 1E02
[0000FFFF - 0000FFFF]	Motherboard resources
[0000FFFF - 0000FFFF]	Motherboard resources

B.2 1st MB Memory Address Map

Address Range	Device Name
[000A0000 - 000BFFFF]	Intel(R) HD Graphics 4000
[000A0000 - 000BFFFF]	PCI bus
[000D0000 - 000D3FFF]	PCI bus
[000D4000 - 000D7FFF]	PCI bus
[000D8000 - 000DBFFF]	PCI bus
[000DC000 - 000DFFFF]	PCI bus
[000E0000 - 000E3FFF]	PCI bus
[000E4000 - 000E7FFF]	PCI bus
[20000000 - 201FFFFFF]	System board
[40004000 - 40004FFF]	System board
[DFA00000 - DFA00FFF]	Motherboard resources
[DFA00000 - FEAFFFFF]	PCI bus
[E0000000 - EFFFFFFF]	Intel(R) HD Graphics 4000
[F0000000 - F003FFF]	Realtek PCIe GBE Family Controller
[F0000000 - F00FFFF]	Intel(R) 7 Series/C216 Chipset Family PCI Express Root Port 8 - 1E1E
[F0100000 - F0103FF]	Realtek PCIe GBE Family Controller #2
[F0100000 - F01FFFF]	Intel(R) 7 Series/C216 Chipset Family PCI Express Root Port 7 - 1E1C
[F7800000 - F7BFFFF]	Intel(R) HD Graphics 4000
[F7C00000 - F7C00FF]	Realtek PCIe GBE Family Controller
[F7C00000 - F7CFFFF]	Intel(R) 7 Series/C216 Chipset Family PCI Express Root Port 8 - 1E1E
[F7D00000 - F7D00FF]	Realtek PCIe GBE Family Controller #2
[F7D00000 - F7DFFFF]	Intel(R) 7 Series/C216 Chipset Family PCI Express Root Port 7 - 1E1C
[F7E00000 - F7E0FFF]	Intel(R) USB 3.0 eXtensible Host Controller
[F7E11000 - F7E110FF]	Intel(R) 7 Series/C216 Chipset Family SMBus Host Controller - 1E22
[F7E12000 - F7E127FF]	Intel(R) 7 Series/C216 Chipset Family SATA AHCI Controller - 1E02
[F7E13000 - F7E133FF]	Intel(R) 7 Series/C216 Chipset Family USB Enhanced Host Controller - 1E26
[F7E14000 - F7E143FF]	Intel(R) 7 Series/C216 Chipset Family USB Enhanced Host Controller - 1E26
[F7E16000 - F7E1600F]	Intel(R) Management Engine Interface
[F8000000 - FBFFFFFF]	Motherboard resources
[FED00000 - FED003FF]	High precision event timer
[FED10000 - FED17FFF]	Motherboard resources
[FED18000 - FED18FFF]	Motherboard resources
[FED19000 - FED19FFF]	Motherboard resources
[FED1C000 - FED1FFFF]	Motherboard resources
[FED20000 - FED3FFFF]	Motherboard resources
[FED40000 - FED44FFF]	System board
[FED45000 - FED8FFFF]	Motherboard resources
[FED90000 - FED93FFF]	Motherboard resources
[FEE00000 - FEEFFFFFF]	Motherboard resources
[FF000000 - FFFFFFFF]	Intel(R) 82802 Firmware Hub Device
[FF000000 - FFFFFFFF]	Motherboard resources

B.3 IRQ Mapping Chart

Interrupt request (IRQ)	Device
(ISA) 0x00000000 (00)	System timer
(ISA) 0x00000003 (03)	Communications Port (COM2)
(ISA) 0x00000004 (04)	Communications Port (COM1)
(ISA) 0x00000006 (06)	Standard floppy disk controller
(ISA) 0x00000008 (08)	System CMOS/real time clock
(ISA) 0x0000000D (13)	Numeric data processor
(ISA) 0x00000051 (81)	Microsoft ACPI-Compliant System
(ISA) 0x00000052 (82)	Microsoft ACPI-Compliant System
(ISA) 0x00000053 (83)	Microsoft ACPI-Compliant System
(ISA) 0x00000054 (84)	Microsoft ACPI-Compliant System
(ISA) 0x00000055 (85)	Microsoft ACPI-Compliant System
(ISA) 0x00000056 (86)	Microsoft ACPI-Compliant System
(ISA) 0x00000057 (87)	Microsoft ACPI-Compliant System
(ISA) 0x00000058 (88)	Microsoft ACPI-Compliant System
(ISA) 0x00000059 (89)	Microsoft ACPI-Compliant System
(ISA) 0x0000005A (90)	Microsoft ACPI-Compliant System
(ISA) 0x0000005B (91)	Microsoft ACPI-Compliant System
(ISA) 0x0000005C (92)	Microsoft ACPI-Compliant System
(ISA) 0x0000005D (93)	Microsoft ACPI-Compliant System
(ISA) 0x0000005E (94)	Microsoft ACPI-Compliant System
(ISA) 0x0000005F (95)	Microsoft ACPI-Compliant System
(ISA) 0x00000060 (96)	Microsoft ACPI-Compliant System
(ISA) 0x00000061 (97)	Microsoft ACPI-Compliant System
(ISA) 0x00000062 (98)	Microsoft ACPI-Compliant System
(ISA) 0x00000063 (99)	Microsoft ACPI-Compliant System
(ISA) 0x00000064 (100)	Microsoft ACPI-Compliant System
(ISA) 0x00000065 (101)	Microsoft ACPI-Compliant System
(ISA) 0x00000066 (102)	Microsoft ACPI-Compliant System
(ISA) 0x00000067 (103)	Microsoft ACPI-Compliant System
(ISA) 0x00000068 (104)	Microsoft ACPI-Compliant System
(ISA) 0x00000069 (105)	Microsoft ACPI-Compliant System
(ISA) 0x0000006A (106)	Microsoft ACPI-Compliant System
(ISA) 0x0000006B (107)	Microsoft ACPI-Compliant System
(ISA) 0x0000006C (108)	Microsoft ACPI-Compliant System
(ISA) 0x0000006D (109)	Microsoft ACPI-Compliant System
(ISA) 0x0000006E (110)	Microsoft ACPI-Compliant System
(ISA) 0x0000006F (111)	Microsoft ACPI-Compliant System
(ISA) 0x00000070 (112)	Microsoft ACPI-Compliant System
(ISA) 0x00000071 (113)	Microsoft ACPI-Compliant System
(ISA) 0x00000072 (114)	Microsoft ACPI-Compliant System
(ISA) 0x00000073 (115)	Microsoft ACPI-Compliant System

 (ISA) 0x00000074 (116)	Microsoft ACPI-Compliant System
 (ISA) 0x00000075 (117)	Microsoft ACPI-Compliant System
 (ISA) 0x00000076 (118)	Microsoft ACPI-Compliant System
 (ISA) 0x00000077 (119)	Microsoft ACPI-Compliant System
 (ISA) 0x00000078 (120)	Microsoft ACPI-Compliant System
 (ISA) 0x00000079 (121)	Microsoft ACPI-Compliant System
 (ISA) 0x0000007A (122)	Microsoft ACPI-Compliant System
 (ISA) 0x0000007B (123)	Microsoft ACPI-Compliant System
 (ISA) 0x0000007C (124)	Microsoft ACPI-Compliant System
 (ISA) 0x0000007D (125)	Microsoft ACPI-Compliant System
 (ISA) 0x0000007E (126)	Microsoft ACPI-Compliant System
 (ISA) 0x0000007F (127)	Microsoft ACPI-Compliant System
 (ISA) 0x00000080 (128)	Microsoft ACPI-Compliant System
 (ISA) 0x00000081 (129)	Microsoft ACPI-Compliant System
 (ISA) 0x00000082 (130)	Microsoft ACPI-Compliant System
 (ISA) 0x00000083 (131)	Microsoft ACPI-Compliant System
 (ISA) 0x00000084 (132)	Microsoft ACPI-Compliant System
 (ISA) 0x00000085 (133)	Microsoft ACPI-Compliant System
 (ISA) 0x00000086 (134)	Microsoft ACPI-Compliant System
 (ISA) 0x00000087 (135)	Microsoft ACPI-Compliant System
 (ISA) 0x00000088 (136)	Microsoft ACPI-Compliant System
 (ISA) 0x00000089 (137)	Microsoft ACPI-Compliant System
 (ISA) 0x0000008A (138)	Microsoft ACPI-Compliant System
 (ISA) 0x0000008B (139)	Microsoft ACPI-Compliant System
 (ISA) 0x0000008C (140)	Microsoft ACPI-Compliant System
 (ISA) 0x0000008D (141)	Microsoft ACPI-Compliant System
 (ISA) 0x0000008E (142)	Microsoft ACPI-Compliant System
 (ISA) 0x0000008F (143)	Microsoft ACPI-Compliant System
 (ISA) 0x00000090 (144)	Microsoft ACPI-Compliant System
 (ISA) 0x00000091 (145)	Microsoft ACPI-Compliant System
 (ISA) 0x00000092 (146)	Microsoft ACPI-Compliant System
 (ISA) 0x00000093 (147)	Microsoft ACPI-Compliant System
 (ISA) 0x00000094 (148)	Microsoft ACPI-Compliant System
 (ISA) 0x00000095 (149)	Microsoft ACPI-Compliant System
 (ISA) 0x00000096 (150)	Microsoft ACPI-Compliant System
 (ISA) 0x00000097 (151)	Microsoft ACPI-Compliant System
 (ISA) 0x00000098 (152)	Microsoft ACPI-Compliant System
 (ISA) 0x00000099 (153)	Microsoft ACPI-Compliant System
 (ISA) 0x0000009A (154)	Microsoft ACPI-Compliant System
 (ISA) 0x0000009B (155)	Microsoft ACPI-Compliant System
 (ISA) 0x0000009C (156)	Microsoft ACPI-Compliant System
 (ISA) 0x0000009D (157)	Microsoft ACPI-Compliant System
 (ISA) 0x0000009E (158)	Microsoft ACPI-Compliant System
 (ISA) 0x0000009F (159)	Microsoft ACPI-Compliant System
 (ISA) 0x000000A0 (160)	Microsoft ACPI-Compliant System
 (ISA) 0x000000A1 (161)	Microsoft ACPI-Compliant System
 (ISA) 0x000000A2 (162)	Microsoft ACPI-Compliant System
 (ISA) 0x000000A3 (163)	Microsoft ACPI-Compliant System
 (ISA) 0x000000A4 (164)	Microsoft ACPI-Compliant System
 (ISA) 0x000000A5 (165)	Microsoft ACPI-Compliant System
 (ISA) 0x000000A6 (166)	Microsoft ACPI-Compliant System
 (ISA) 0x000000A7 (167)	Microsoft ACPI-Compliant System
 (ISA) 0x000000A8 (168)	Microsoft ACPI-Compliant System
 (ISA) 0x000000A9 (169)	Microsoft ACPI-Compliant System

(ISA) 0x000000AA (170)	Microsoft ACPI-Compliant System
(ISA) 0x000000AB (171)	Microsoft ACPI-Compliant System
(ISA) 0x000000AC (172)	Microsoft ACPI-Compliant System
(ISA) 0x000000AD (173)	Microsoft ACPI-Compliant System
(ISA) 0x000000AE (174)	Microsoft ACPI-Compliant System
(ISA) 0x000000AF (175)	Microsoft ACPI-Compliant System
(ISA) 0x000000B0 (176)	Microsoft ACPI-Compliant System
(ISA) 0x000000B1 (177)	Microsoft ACPI-Compliant System
(ISA) 0x000000B2 (178)	Microsoft ACPI-Compliant System
(ISA) 0x000000B3 (179)	Microsoft ACPI-Compliant System
(ISA) 0x000000B4 (180)	Microsoft ACPI-Compliant System
(ISA) 0x000000B5 (181)	Microsoft ACPI-Compliant System
(ISA) 0x000000B6 (182)	Microsoft ACPI-Compliant System
(ISA) 0x000000B7 (183)	Microsoft ACPI-Compliant System
(ISA) 0x000000B8 (184)	Microsoft ACPI-Compliant System
(ISA) 0x000000B9 (185)	Microsoft ACPI-Compliant System
(ISA) 0x000000BA (186)	Microsoft ACPI-Compliant System
(ISA) 0x000000BB (187)	Microsoft ACPI-Compliant System
(ISA) 0x000000BC (188)	Microsoft ACPI-Compliant System
(ISA) 0x000000BD (189)	Microsoft ACPI-Compliant System
(ISA) 0x000000BE (190)	Microsoft ACPI-Compliant System
(PCI) 0x0000000F (15)	Intel(R) 7 Series/C216 Chipset Family SMBus Host Controller - 1E22
(PCI) 0x00000010 (16)	Intel(R) 7 Series/C216 Chipset Family USB Enhanced Host Controller - 1E2D
(PCI) 0x00000010 (16)	Intel(R) 7 Series/C216 Chipset Family PCI Express Root Port 1 - 1E10
(PCI) 0x00000010 (16)	Intel(R) Management Engine Interface
(PCI) 0x00000012 (18)	Intel(R) 7 Series/C216 Chipset Family PCI Express Root Port 7 - 1E1C
(PCI) 0x00000013 (19)	Intel(R) 7 Series/C216 Chipset Family PCI Express Root Port 8 - 1E1E
(PCI) 0x00000013 (19)	Intel(R) 7 Series/C216 Chipset Family SATA AHCI Controller - 1E02
(PCI) 0x00000017 (23)	Intel(R) 7 Series/C216 Chipset Family USB Enhanced Host Controller - 1E26
(PCI) 0xFFFFFFFF (-5)	Realtek PCIe GBE Family Controller
(PCI) 0xFFFFFFFF (-4)	Realtek PCIe GBE Family Controller #2
(PCI) 0xFFFFFFFF (-3)	Intel(R) USB 3.0 eXtensible Host Controller
(PCI) 0xFFFFFFFF (-2)	Intel(R) HD Graphics 4000

B.4 DMA Channel Assignments

Direct memory access (DMA)
2 Standard floppy disk controller
4 Direct memory access controller

Appendix

C

Mating Connector

C.1 List of Mating Connectors and Cables

The table notes mating connectors and available cables.

Connector Label	Function	Mating Connector		Available Cable	Cable P/N
		Vendor	Model no		
SATA1	SATA Connector	TECHBEST	161S01-029A-L	SATA Cable	1709070800
SATA2	SATA Connector	TECHBEST	161S01-025A	SATA Cable	1709070800
SATA3	SATA Connector	TECHBEST	161S01-025A	SATA Cable	1709070800
LPT1	Parallel Port Connector	Catch Electronics	1147-000-26S	LPT Cable	1701260307
FP1	Front Panel Connector	JIH VEI Electronics	21B22564-XXS 10B-01G-6/3-V XX		N/A
FP2	Front Panel Connector	JIH VEI Electronics	21B22564-XXS 10B-01G-6/3-V XX		N/A
USB1	USB 3.0 Connector	PINREX	52X-40-20GV52		NA
USB2	USB Connector	JIH VEI Electronics	21B22564-10S1 0B-01G-6/3-V10	USB Cable	1709100204
USB4	USB Connector	HO-BASE	KS-001V-ANW		NA
USB5	USB 3.0 Connector	PINREX	52X-40-20GV52		NA
USB6	USB Connector	HO-BASE	KS-001V-ANW		NA
COM1	COM Port Connector	Catch Electronics	1147-000-10S	Serial Port Cable	1701100305
COM2	COM Port Connector	Catch Electronics	1147-000-10S	Serial Port Cable	1701100305
DIO1	DIO Port Connector	Catch Electronics	1147-000-10S		N/A

Full-size SBC

FSB - B75H

CPU_FAN	FAN Connector	Catch Electronics	1190-700-042		N/A
SYS_FAN1	FAN Connector	Catch Electronics	1190-700-042		N/A
DIMM1	DDR3 204PIN SKT	KORTAK	AR240H-101B-A0H		N/A
DIMM2	DDR3 204PIN SKT	KORTAK	AR240H-101B-A0H		N/A
FDD1	Floppy Connector	Catch Electronics	1137-000-34SA		NA
DVI1	DVI-I Connector	KORTAK	9D0290-08SC-00H		NA
VGA1	VGA Connector	Astron	HDLH-B15-CFH N1T-1-R		NA
LAN1	LAN Connector	UDE	RDA-1A5BAK1A		NA
LAN2	LAN Connector	UDE	RDA-1A5BAK1A		NA
CN5	CFast Connector	3M	N7G24-A0B2R A-10-0HT-DY		NA

Appendix

D

AHCI Settings

D.1 Setting AHCI

OS Installation to Setup AHCI mode

Step 1: Copy the files below from the **Driver CD: Step 6 - AHCI\Driver\winxp_32 or winxp_64** to Disk.



Step 2: Connect the USB Floppy Disk with the AHCI files to the board.

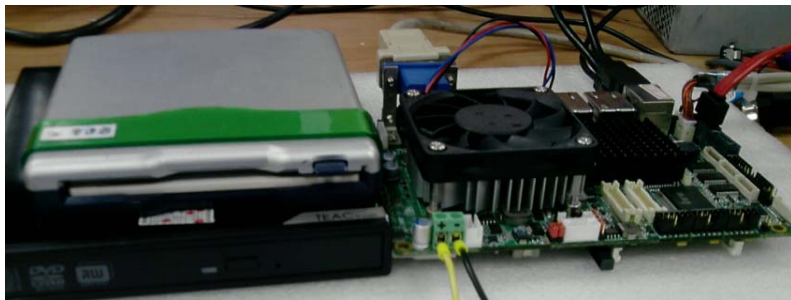

Step 3: To install “In BIOS Setup Menu”, select **Advanced -> SATA Configuration -> SATA Mode Selection -> AHCI**

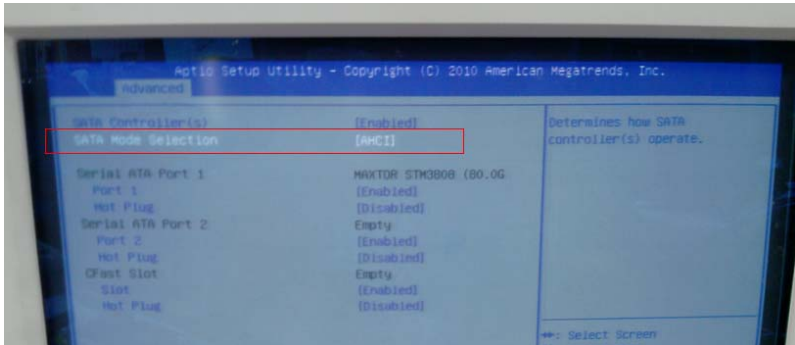

Step 4: Next, select **Boot -> Boot Option #1 -> DVD ROM Type**

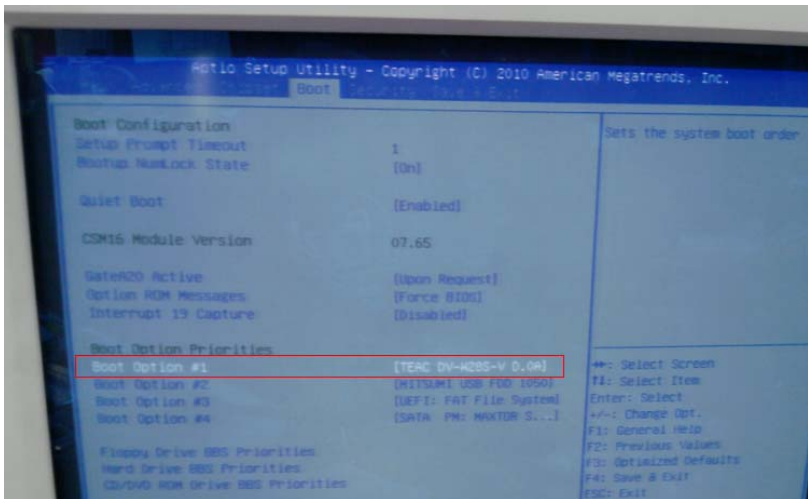

Step 5: To save, select **Save & Exit** -> **Save Changes and Exit**

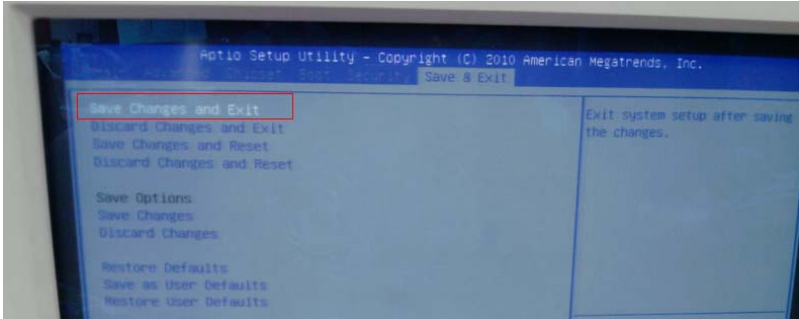

Step 6: Setup OS

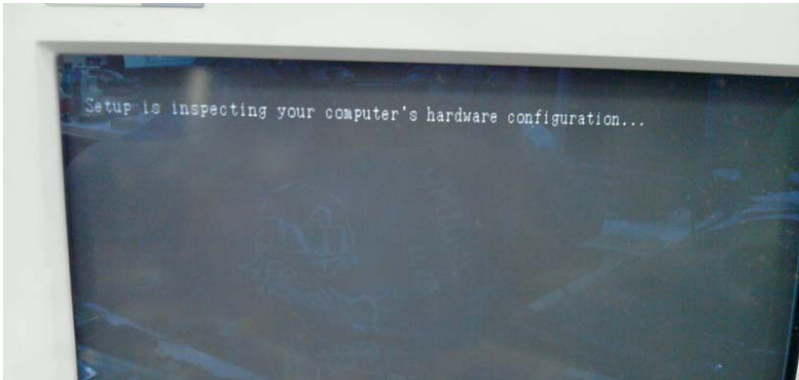

Step 7: Press “F6”

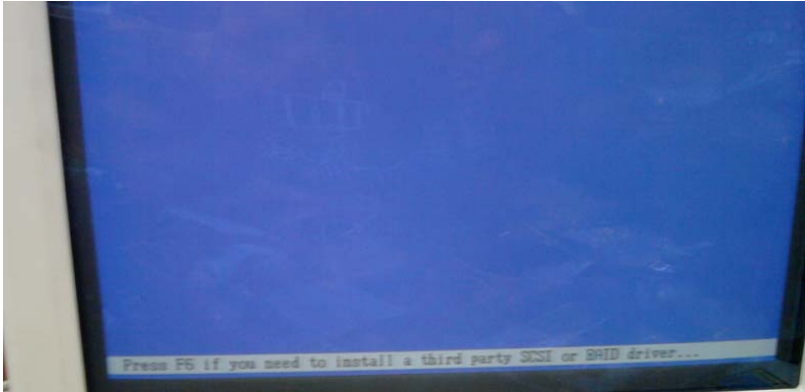

Step 8: Choose “S”

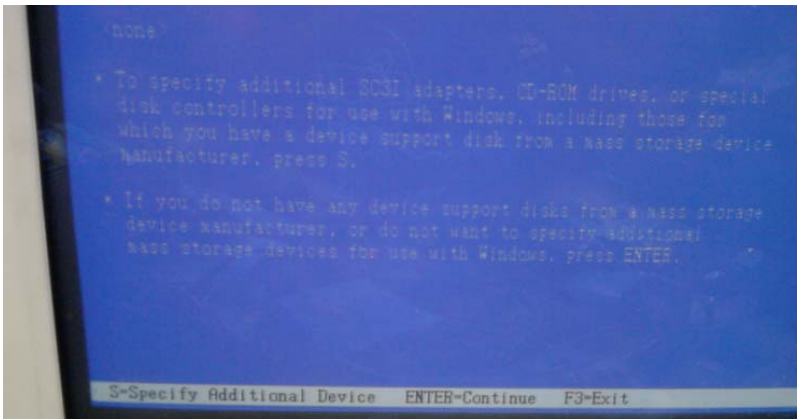

Step 9:

Mobile

Choose “Intel(R) 7 Series Chipset Family SATA AHCI Controller”



Desktop

Choose “Intel(R) 7 Series/C216 Chipset Family SATA AHCI Controller”



Step 10: Select “ENTER” to choose the model number

Mobile



Desktop



Step 11: Setup is loading files

