

# EPIC-KBS7

---

EPIC Board

User's Manual 6<sup>th</sup> Ed

## Copyright Notice

---

This document is copyrighted, 2023. All rights are reserved. The original manufacturer reserves the right to make improvements to the products described in this manual at any time without notice.

No part of this manual may be reproduced, copied, translated, or transmitted in any form or by any means without the prior written permission of the original manufacturer. Information provided in this manual is intended to be accurate and reliable. However, the original manufacturer assumes no responsibility for its use, or for any infringements upon the rights of third parties that may result from its use.

The material in this document is for product information only and is subject to change without notice. While reasonable efforts have been made in the preparation of this document to assure its accuracy, AAEMON assumes no liabilities resulting from errors or omissions in this document, or from the use of the information contained herein.

AAEMON reserves the right to make changes in the product design without notice to its users.

## Acknowledgement

---

All other products' name or trademarks are properties of their respective owners.

- Microsoft Windows® is a registered trademark of Microsoft Corp.
- Intel® is a registered trademark of Intel Corporation
- Intel Core™ is a trademark of Intel Corporation
- ITE is a trademark of Integrated Technology Express, Inc.
- IBM, PC/AT, PS/2, and VGA are trademarks of International Business Machines Corporation.
- Ubuntu and Canonical are registered trademarks of Canonical Ltd.
- Realtek is a trademark of Realtek Semiconductor Corporation

All other product names or trademarks are properties of their respective owners.

## Packing List

---

Before setting up your product, please make sure you have received the following items:

Item	Quantity
● EPIC-KBS7	1
● SATA Cable	2
● SATA Power Cable	1
● Screw Kit	1
● CPU Cover	1

If any of these items are missing or damaged, please contact your distributor or sales representative immediately.

## About this Document

---

This User's Manual contains all the essential information, such as detailed descriptions and explanations on the product's hardware and software features (if any), its specifications, dimensions, jumper/connector settings and definitions, and driver installation instructions (if any), to facilitate users in setting up their product.

Users may refer to the product page at [AAEON.com](http://AAEON.com) for the latest version of this document.

## Safety Precautions

---

Please read the following safety instructions carefully. It is advised that you keep this manual for future references

1. All cautions and warnings on the device should be noted.
2. Make sure the power source matches the power rating of the device.
3. Position the power cord so that people cannot step on it. Do not place anything over the power cord.
4. Always completely disconnect the power before working on the system's hardware.
5. No connections should be made when the system is powered as a sudden rush of power may damage sensitive electronic components.
6. If the device is not to be used for a long time, disconnect it from the power supply to avoid damage by transient over-voltage.
7. Always disconnect this device from any AC supply before cleaning.
8. While cleaning, use a damp cloth instead of liquid or spray detergents.
9. Make sure the device is installed near a power outlet and is easily accessible.
10. Keep this device away from humidity.
11. Place the device on a solid surface during installation to prevent falls
12. Do not cover the openings on the device to ensure optimal heat dissipation.
13. Watch out for high temperatures when the system is running.
14. Do not touch the heat sink or heat spreader when the system is running
15. Never pour any liquid into the openings. This could cause fire or electric shock.
16. As most electronic components are sensitive to static electrical charge, be sure to ground yourself to prevent static charge when installing the internal components. Use a grounding wrist strap and contain all electronic components in any static-shielded containers.

17. If any of the following situations arises, please the contact our service personnel:
  - i. Damaged power cord or plug
  - ii. Liquid intrusion to the device
  - iii. Exposure to moisture
  - iv. Device is not working as expected or in a manner as described in this manual
  - v. The device is dropped or damaged
  - vi. Any obvious signs of damage displayed on the device
18. **DO NOT LEAVE THIS DEVICE IN AN UNCONTROLLED ENVIRONMENT WITH TEMPERATURES BEYOND THE DEVICE'S PERMITTED STORAGE TEMPERATURES (SEE CHAPTER 1) TO PREVENT DAMAGE.**

### **Warning!**



This device complies with Part 15 FCC Rules. Operation is subject to the following two conditions: (1) this device may not cause harmful interference, and (2) this device must accept any interference received including interference that may cause undesired operation.

### **Caution:**

*There is a danger of explosion if the battery is incorrectly replaced. Replace only with the same or equivalent type recommended by the manufacturer. Dispose of used batteries according to the manufacturer's instructions and your local government's recycling or disposal directives.*

### **Attention:**

*Il y a un risque d'explosion si la batterie est remplacée de façon incorrecte. Ne la remplacer qu'avec le même modèle ou équivalent recommandé par le constructeur. Recycler les batteries usées en accord avec les instructions du fabricant et les directives gouvernementales de recyclage.*



## China RoHS Requirements (CN)

产品中有毒有害物质或元素名称及含量

AAEON Main Board/ Daughter Board/ Backplane

部件名称	有毒有害物质或元素					
	铅 (Pb)	汞 (Hg)	镉 (Cd)	六价铬 (Cr(VI))	多溴联苯 (PBB)	多溴二苯醚 (PBDE)
印刷电路板 及其电子组件	X	X	○	○	○	○
外部信号 连接器及线材	X	X	○	○	○	○

O: 表示该有毒有害物质在该部件所有均质材料中的含量均在 SJ/T 11363-2006 标准规定的限量要求以下。

X: 表示该有毒有害物质至少在该部件的某一均质材料中的含量超出 SJ/T 11363-2006 标准规定的限量要求。

备注: 此产品所标示之环保使用期限, 系指在一般正常使用状况下。

## China RoHS Requirement (EN)

Poisonous or Hazardous Substances or Elements in Products

AAEON Main Board/ Daughter Board/ Backplane

Component	Poisonous or Hazardous Substances or Elements					
	Lead (Pb)	Mercury (Hg)	Cadmium (Cd)	Hexavalent Chromium (Cr(VI))	Polybrominated Biphenyls (PBB)	Polybrominated Diphenyl Ethers (PBDE)
PCB & Other Components	X	X	○	○	○	○
Wires & Connectors for External Connections	X	X	○	○	○	○
<p>○: The quantity of poisonous or hazardous substances or elements found in each of the component's parts is below the SJ/T 11363-2006-stipulated requirement.</p> <p>X: The quantity of poisonous or hazardous substances or elements found in at least one of the component's parts is beyond the SJ/T 11363-2006-stipulated requirement.</p> <p><b>Note:</b> The Environment Friendly Use Period as labeled on this product is applicable under normal usage only</p>						

## Table of Contents

---

<b>Chapter 1 - Product Specifications</b> .....	<b>1</b>
1.1 Specifications .....	2
1.2 Block Diagram .....	6
<b>Chapter 2 – Hardware Information</b> .....	<b>7</b>
2.1 Dimensions .....	8
2.2 Jumpers and Connectors.....	10
2.3 List of Jumpers .....	12
2.3.1 LVDS Power Select/LVDS BKLT Power Select (JP4).....	12
2.3.2 LVDS Backlight Brightness Control Mode Select (JP5).....	13
2.3.3 Clear CMOS (JP6) .....	13
2.3.4 AT/ATX Select (JP7).....	13
2.3.5 Front Panel Header (JP9).....	14
2.4 List of Connectors.....	15
2.4.1 Backlight Connector (CN1).....	17
2.4.2 2-Pin DC IN Connector (CN2).....	17
2.4.3 LVDS Connector (CN3) .....	18
2.4.4 External +5VSB Input Connector (CN4).....	20
2.4.5 Audio Pin Header (CN5) .....	20
2.4.6 RTC Battery Connector (CN6).....	21
2.4.7 SATA Power Connector (CN7) .....	21
2.4.8 USB 2.0 Pin Header (CN8/CN9) .....	22
2.4.9 SATA Port 2 (CN10).....	22
2.4.10 SATA Port 1 (CN13).....	23
2.4.11 External Fan Pin Header (CN14).....	24
2.4.12 LPC Connector for Debug (CN15).....	24
2.4.13 COM 2 RS232/422/485 Pin Header (CN16) .....	25

2.4.14	COM 1 RS-232 Pin Header (CN17)	28
2.4.15	COM 3 RS-232 Pin Header (CN18)	29
2.4.16	DIO Pin Header (CN24)	30
2.4.17	COM 4 RS-232 Pin Header (CN26)	31
2.4.18	USB 3.0 Ports (CN21/CN22)	32
2.4.19	Mini Card Connector (CN11)	33
2.4.20	RJ-45 LAN (CN19/CN20)	35
2.4.21	HDMI Port (CN23)	35
2.4.22	VGA Port (CN25)	36
2.5	CPU Installation	38
<b>Chapter 3 - BIOS Setup</b>		<b>41</b>
3.1	System Test and Initialization	42
3.2	AMI BIOS Setup	43
3.3	Setup Submenu: Main	44
3.4	Setup Submenu: Advanced	45
3.4.1	CPU Configuration	46
3.4.2	SATA Configuration	47
3.4.3	SIO Configuration	48
3.4.3.1	Serial Port Configuration	49
3.4.4	Hardware Monitor	50
3.4.4.1	CPU Smart Fan Mode Configuration	51
3.4.5	USB Configuration	54
3.4.6	Digital IO Port Configuration	55
3.4.7	Power Management	56
3.5	Setup Submenu: Chipset	57
3.5.1	System Agent (SA) Configuration	58
3.5.1.1	Graphics Configuration	59
3.5.1.2	LVDS Panel Configuration	61

3.5.2	PCH-IO Configuration .....	63
3.6	Setup Submenu: Security .....	64
3.7	Setup Submenu: Boot .....	65
3.7.1	BBS Priorities .....	66
3.8	Setup Submenu: Save & Exit .....	67
<b>Chapter 4</b>	<b>– Drivers Installation .....</b>	<b>68</b>
4.1	Driver Installation .....	69
<b>Appendix A</b>	<b>- I/O Information .....</b>	<b>71</b>
A.1	I/O Address Map .....	72
A.2	Memory Address Map .....	74
A.3	IRQ Mapping Chart .....	76
<b>Appendix B</b>	<b>– Mating Connector Information .....</b>	<b>78</b>
B.1	Mating Connectors .....	79

# Chapter 1

---

Product Specifications

## 1.1 Specifications

---

### System

Form Factor	4" EPIC Board
CPU	6th/7th Generation Intel Core™ Processor (up to 35W/54W): Intel® Core™ i7-7700T (4C/8T, 2.9 GHz, 35W) Intel® Core™ i5-7500T (4C/4T, 2.7 GHz, 35W) Intel® Core™ i3-7100T (2C/4T, 3.4 GHz, 35W) Intel® Core™ i7-6700TE (4C/8T, 2.4 GHz, 35W) Intel® Core™ i5-6500TE (4C/4T, 2.3 GHz, 35W) Intel® Core™ i3-6100TE (2C/4T, 2.7 GHz, 35W)
Chipset	Intel® 100 Series Mobile Chipset (H110/Q170)
Memory Type	DDR4 2133, Single Channel SODIMM x 1, up to 16GB (Non-ECC Support)
BIOS	UEFI
Wake on LAN	Yes
Watchdog Timer	255 Levels
Security	-
RTC Battery	Lithium Battery 3V/240mAh
Dimension	4.53" x 6.50" (115mm x 165mm)
OS Support	Windows 10 (64-bit) Ubuntu 21.04/Kernel 5.11.0-13-generic

### Power

Power Requirement	+9V to +24V (Optional: +12V)
Power Supply Type	AT/ATX
Connector	2-Pin Phoenix Connector

## Power

Power Consumption	Intel® Core™ i7-6700TE, DDR4 16GB, 3.50A @12V, 49.8W
-------------------	--

## Display

Controller	Intel® HD Graphics 630 Intel® HD Graphics 530 (by CPU SKU)
LVDS/eDP	LVDS x 1, Dual Channel 24/48-bit, up to 1920 x 1080 (Q170 SKU support only)
Display Interface	VGA x 1, up to 1920 x 1080 HDMI x 1, up to 3840 x 2160 @60Hz
Multiple Display	Up to 3 Simultaneous Displays

## Audio

Codec	Realtek ALC897
Audio Interface	Line-In/Line-Out/Mic
Speaker	-

## External I/O

Ethernet	Intel® I210-AT, 1GbE RJ-45 x 2
USB	USB 3.2 Gen 1 x 4
Serial Port	-
Video	VGA x 1, up to 1920 x 1080 HDMI x 1, up to 3840 x 2160 @60Hz



## Internal I/O

USB	USB 2.0 x 2
Serial Port	COM 2 (RS-232/422/485, supports 5V/12V/RI) COM 1, COM 3, COM 4 (RS-232 only, supports RI only)
Video	LVDS x 1 (Q170 SKU support only) LVDS Inverter 5V/12V @2A
SATA	SATA 6Gb/s x 2 +5V SATA Power Connector x 1 (Total up to 5V@2A) (Up to 5V@1A, shared with 2 x 2.5"SSD as limitation with 1709070150)
Audio	Pin Header (Line in/Line out/Mic)
DIO/GPIO	GPIO 8-bit
SMBus/I2C	SMBus/I2C (Default: SMBus)
Touch	-
Fan	4 Pin Smart Fan
SIM	Micro SIM x 1 (Optional)
Front Panel	Power Button, Reset Button, Power LED, SATA LED, Buzzer
Others	-

## Expansion

Mini PCIe/mSATA	Full Size mSATA/mPCIe (Default: mSATA) (H110 SKU mPCIe by BOM Optional, Q170 SKU mPCIe selected by BIOS)
M.2	-
Others	-

## Environmental

Operating Temperature	32°F ~ 140°F (0°C ~ 60°C)
Storage Temperature	-40°F ~ 185°F (-40°C ~ 85°C)
Operating Humidity	0% ~ 90% relative humidity, non-condensing
MTBF (Hours)	393,440
EMC	CE/FCC Class A

## 1.2 Block Diagram

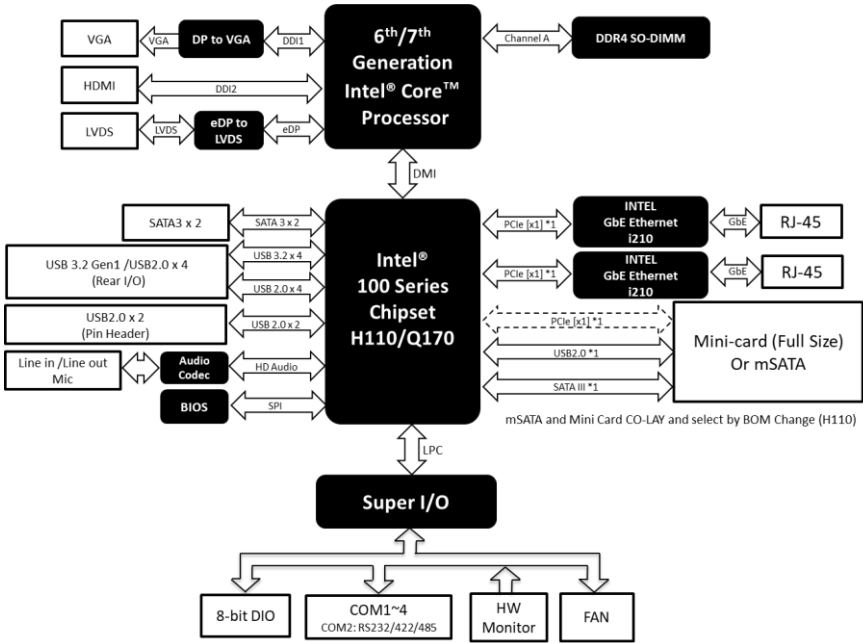

# Chapter 2

---

Hardware Information

## 2.1 Dimensions

### Component Side

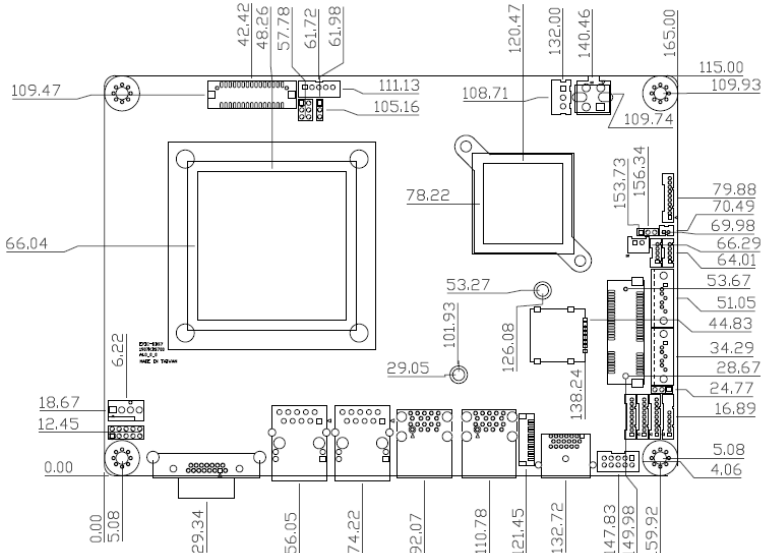

### Solder Side

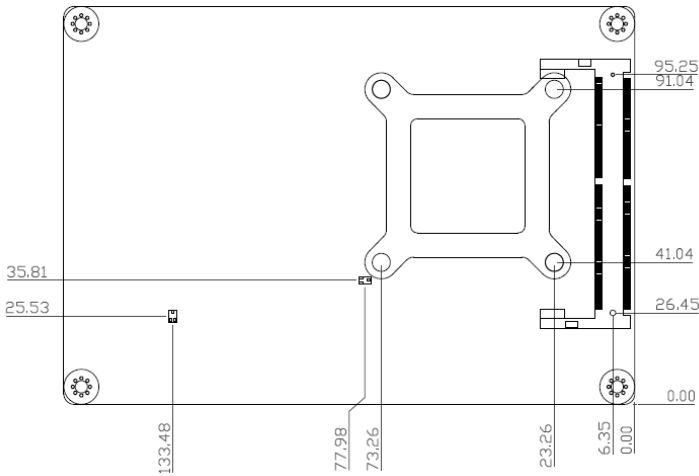

Side View with Thermal Solution

EPIC-KBS7-FAN01

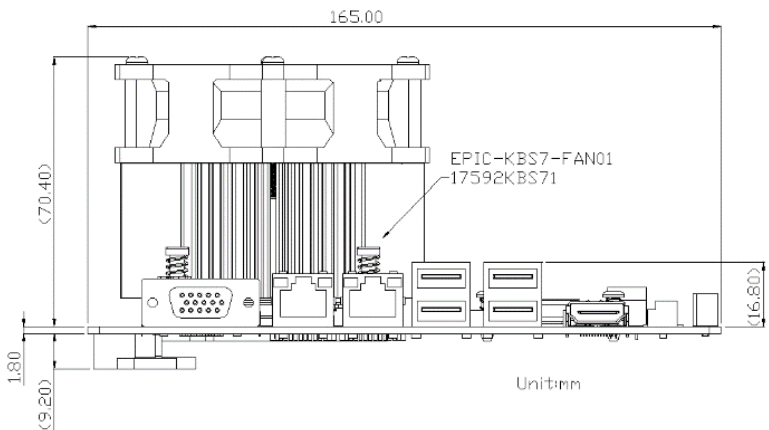

EPIC-KBS7-FAN02

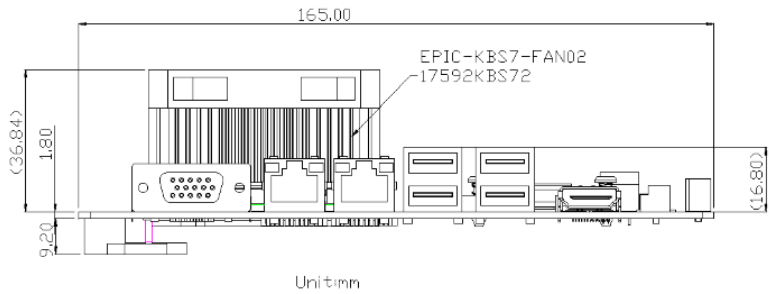

## 2.2 Jumpers and Connectors

### Component Side

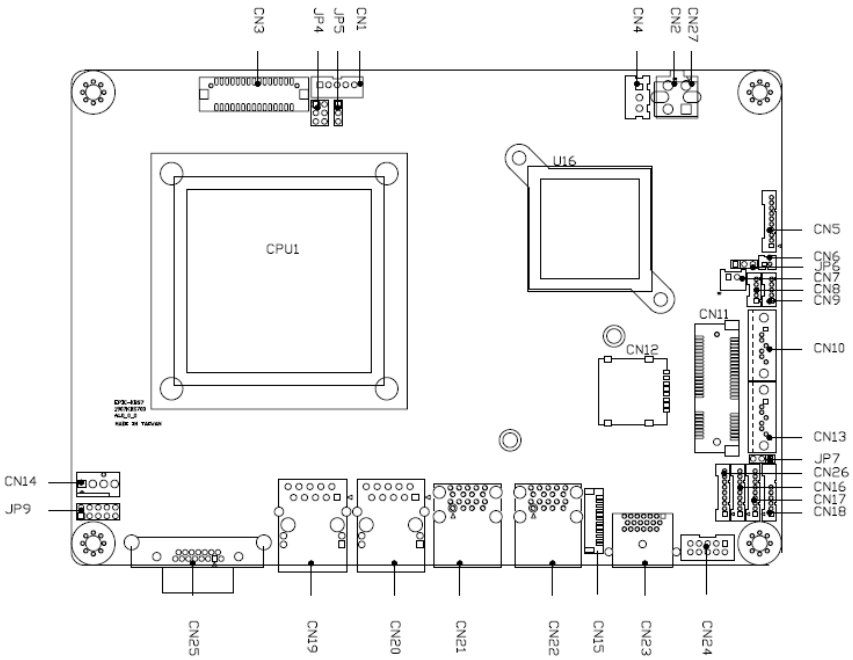

### Solder Side

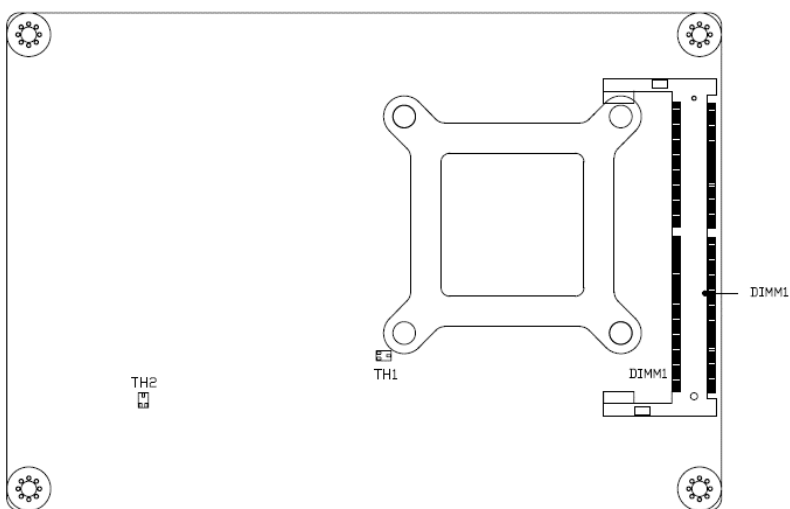



## 2.3 List of Jumpers

Please refer to the table below for all of the board's jumpers that you can configure for your application

Label	Function
JP4	LVDS Power Select/LVDS BKLT Power Select
JP5	LVDS Backlight Brightness Control Mode Select
JP6	Clear CMOS
JP7	AT/ATX Select
JP9	Front Panel Pin Header

### 2.3.1 LVDS Power Select/LVDS BKLT Power Select (JP4)

LVDS Power Select

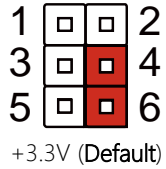
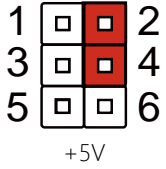

LVDS BKLT Power Select

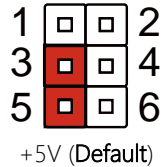
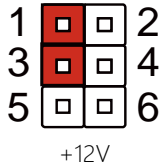

**Note:** To prevent unwanted operation or damage to the system, do not connect pins in any other configuration than what is shown.

### 2.3.2 LVDS Backlight Brightness Control Mode Select (JP5)

---

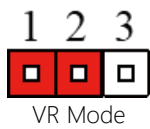

VR Mode

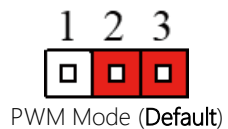

PWM Mode (Default)

### 2.3.3 Clear CMOS (JP6)

---

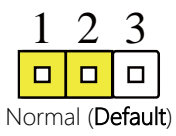

Normal (Default)

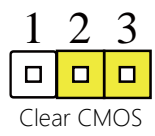

Clear CMOS

### 2.3.4 AT/ATX Select (JP7)

---

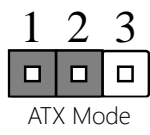

ATX Mode

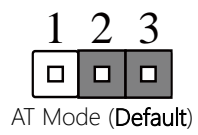

AT Mode (Default)

### 2.3.5 Front Panel Header (JP9)

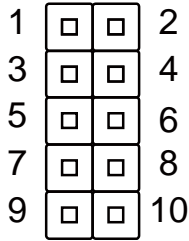

Pin	Pin Name	Pin	Pin Name
1	PWR_BTN-	2	PWR_BTN+
3	HDD_LED-	4	HDD_LED+
5	FP_BUZZER-	6	BUZZER+
7	PWR_LED-	8	PWR_LED+
9	H/W RESET-	10	H/W RESET+

## 2.4 List of Connectors

---

Please refer to the table below for all of the board's connectors that you can configure for your application

Label	Function
BZ1	PC Buzzer
CN1	Backlight Connector
CN2	2-Pin DC In Connector
CN3	LVDS Connector
CN4	External +5VSB Input Connector
CN5	Audio Pin Header
CN6	RTC Battery Connector
CN7	SATA Power Connector
CN8	USB 2.0 Connector
CN9	USB 2.0 Connector
CN10	SATA Port 2
CN11	Mini Card Connector
CN12	SIM Card Connector
CN13	SATA Port 1
CN14	External Fan Pin Header
CN15	LPC Connector for Debug
CN16	COM 2 RS-232/422/485 Pin Header
CN17	COM 1 RS-232 Pin Header
CN18	COM 3 RS-232 Pin Header
CN19	Gigabit LAN RJ-45 Connector
CN20	Gigabit LAN RJ-45 Connector
CN21	USB 3.0 Connector
CN22	USB 3.0 Connector

Label	Function
CN23	HDMI Connector
CN24	DIO Connector
CN25	VGA Connector
CN26	COM 4 RS-232 Pin Header
CPU1	CPU Socket
DIMM1	RAM Socket 1
LED1	Standby Power LED Indicator
LED2	+V5S LED Indicator
LED3	HDD LED Indicator
U18	SPI ROM

## 2.4.1 Backlight Connector (CN1)

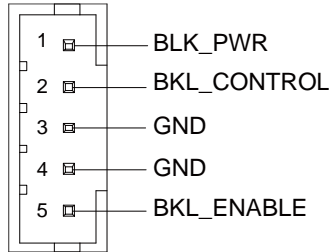

Pin	Pin Name	Signal Type	Signal Level
1	BKL_PWR	PWR	+5V / +12V
2	BKL_CONTROL	OUT	
3	GND	GND	
4	GND	GND	
5	BKL_ENABLE	OUT	+5V

**Note 1:** LVDS BKL\_PWR can be set to +5V or +12V by JP4. Driving current supports up to 2A.

**Note 2:** LVDS BKL\_CONTROL can be set by JP5.

## 2.4.2 2-Pin DC IN Connector (CN2)

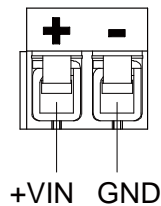

Pin	Pin Name	Signal Type	Signal Level
1	+12V	PWR	+9~24V (or +12V)
2	GND	GND	

**Note:** Pin 1 max current rating is 9A.

### 2.4.3 LVDS Connector (CN3)

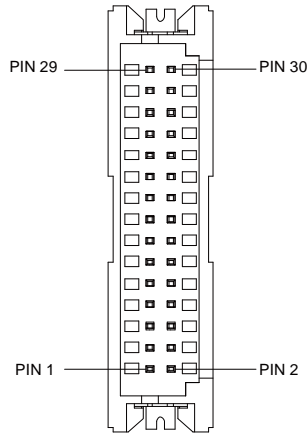

Pin	Pin Name	Signal Type	Signal Level
1	BKL_ENABLE	OUT	
2	BKL_CONTROL	OUT	
3	LCD_PWR	PWR	+3.3V/+5V
4	GND	GND	
5	LVDS_A_CLK-	DIFF	
6	LVDS_A_CLK+	DIFF	
7	LCD_PWR	PWR	+3.3V/+5V
8	GND	GND	
9	LVDS_DA0-	DIFF	
10	LVDS_DA0+	DIFF	
11	LVDS_DA1-	DIFF	
12	LVDS_DA1+	DIFF	
13	LVDS_DA2-	DIFF	
14	LVDS_DA2+	DIFF	

Pin	Pin Name	Signal Type	Signal Level
15	LVDS_DA3-	DIFF	
16	LVDS_DA3+	DIFF	
17	DDC_DATA	I/O	+3.3V
18	DDC_CLK	I/O	+3.3V
19	LVDS_DB0-	DIFF	
20	LVDS_DB0+	DIFF	
21	LVDS_DB1-	DIFF	
22	LVDS_DB1+	DIFF	
23	LVDS_DB2-	DIFF	
24	LVDS_DB2+	DIFF	
25	LVDS_DB3-	DIFF	
26	LVDS_DB3+	DIFF	
27	LCD_PWR	PWR	+3.3V/+5V
28	GND	GND	
29	LVDS_B_CLK-	DIFF	
30	LVDS_B_CLK+	DIFF	

**Note:** LVDS LCD\_PWR can be set to +3.3V or +5V by JP4. LCD\_PWR supports max current of 2A.



### 2.4.4 External +5VSB Input Connector (CN4)

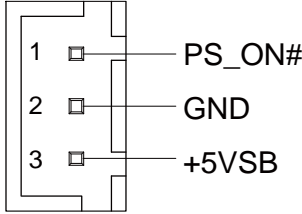

Pin	Pin Name	Signal Type	Signal Level
1	PS_ON#	OUT	+3.3V
2	GND	GND	
3	+5VSB	PWR	+5V

**Note:** Maximum current rating of Pin#3/+5VSB is 2A

### 2.4.5 Audio Pin Header (CN5)

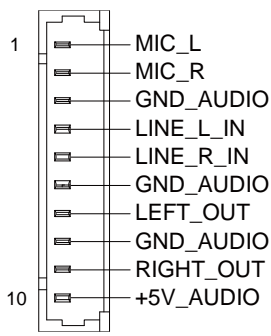

Pin	Pin Name	Signal Type	Signal Level
1	MIC_L	IN	
2	MIC_R	IN	
3	GND_AUDIO	GND	
4	LINE_L_IN	IN	

Pin	Pin Name	Signal Type	Signal Level
5	LINE_R_IN	IN	
6	GND_AUDIO	GND	
7	LEFT_OUT	OUT	
8	GND_AUDIO	GND	
9	RIGHT_OUT	OUT	
10	+5V_AUDIO	PWR	+5V

#### 2.4.6 RTC Battery Connector (CN6)

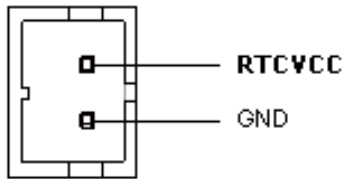

Pin	Pin Name	Signal Type	Signal Level
1	RTCVCC	PWR	+3.3V
2	GND	GND	

#### 2.4.7 SATA Power Connector (CN7)

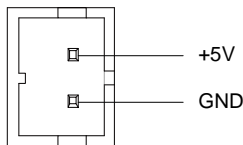

Pin	Pin Name	Signal Type	Signal Level
1	+5V	PWR	+5V
2	GND	GND	

**Note:** +5V Output for SATA HDD max current 1A.

### 2.4.8 USB 2.0 Pin Header (CN8/CN9)

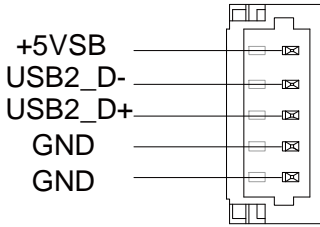

Pin	Pin Name	Signal Type	Signal Level
1	+5VSB	PWR	+5V
2	USB_D-	DIFF	
3	USB_D+	DIFF	
4	GND	GND	
5	GND	GND	

**Note:** USB 2.0 ports support max current 0.5A.

### 2.4.9 SATA Port 2 (CN10)

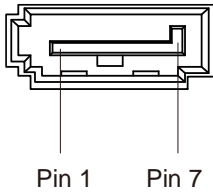

Pin	Pin Name	Signal Type	Signal Level
1	GND	GND	
2	SATA_TX+	DIFF	
3	SATA_TX-	DIFF	
4	GND	GND	

Pin	Pin Name	Signal Type	Signal Level
5	SATA_RX-	DIFF	
6	SATA_RX+	DIFF	
7	GND	GND	

#### 2.4.10 SATA Port 1 (CN13)

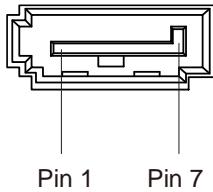

Pin	Pin Name	Signal Type	Signal Level
1	GND	GND	
2	SATA_TX+	DIFF	
3	SATA_TX-	DIFF	
4	GND	GND	
5	SATA_RX-	DIFF	
6	SATA_RX+	DIFF	
7	GND	GND	

### 2.4.11 External Fan Pin Header (CN14)

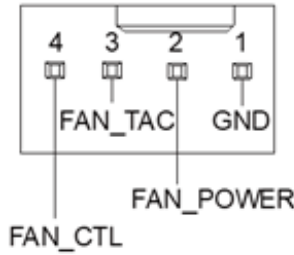

Pin	Pin Name	Signal Type	Signal Level
1	GND	GND	
2	FAN_POWER	PWR	+12V
3	FAN_TAC	IN	
4	FAN_CTL	OUT	+3.3V

**Note:** +12V output for FAN power max current 2A.

### 2.4.12 LPC Connector for Debug (CN15)

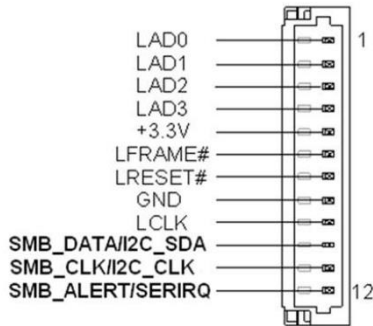

Pin	Pin Name	Signal Type	Signal level
1	LPC_AD0	I/O	
2	LPC_AD1	I/O	

Pin	Pin Name	Signal Type	Signal level
3	LPC_AD2	I/O	
4	LPC_AD3	I/O	
5	+V3.3S	PWR	+3.3V
6	FRAME#	OUT	
7	RST#	OUT	
8	GND	GND	
9	CLK	OUT	
10	SMB_DAT/I2C_SDA	I/O	
11	SMB_CLK/I2C_CLK	I/O	
12	SMB_ALERT/SERIRQ	I/O	

### 2.4.13 COM 2 RS232/422/485 Pin Header (CN16)

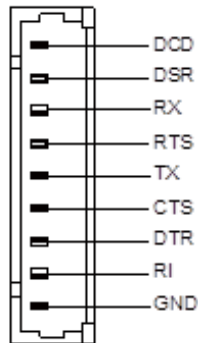

#### RS-232

Pin	Pin Name	Signal Type	Signal Level
1	DCD	IN	
2	DSR	IN	
3	RX	IN	
4	RTS	OUT	±5V

RS-232			
Pin	Pin Name	Signal Type	Signal Level
5	TX	OUT	±5V
6	CTS	IN	
7	DTR	OUT	±5V
8	RI/+5V/+12V	IN/ PWR	+5V/+12V
9	GND	GND	

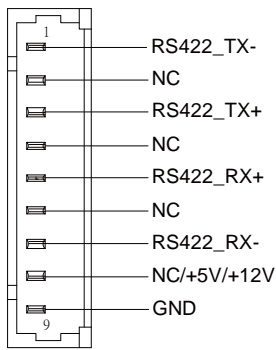

RS-422			
Pin	Pin Name	Signal Type	Signal Level
1	RS422_TX-	OUT	±5V
2	NC		
3	RS422_TX+	OUT	±5V
4	NC		
5	RS422_RX+	IN	
6	NC		
7	RS422_RX-	IN	
8	NC/+5V/+12V	PWR	+5V/+12V
9	GND	GND	

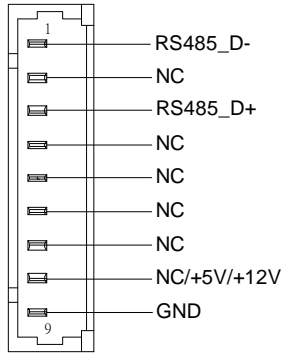

RS-485			
Pin	Pin Name	Signal Type	Signal Level
1	RS485_D-	I/O	±5V
2	NC		
3	RS485_D+	I/O	±5V
4	NC		
5	NC		
6	NC		
7	NC		
8	NC/+5V/+12V	PWR	+5V/+12V
9	GND	GND	

**Note 1:** COM 4 RS-232/422/485 can be set by BIOS. Default is RS-232.



## 2.4.14 COM 1 RS-232 Pin Header (CN17)

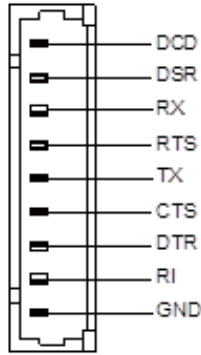

Pin	Pin Name	Signal Type	Signal Level
1	DCD	IN	
2	DSR	IN	
3	RX	IN	
4	RTS	OUT	±5V
5	TX	OUT	±5V
6	CTS	IN	
7	DTR	OUT	±5V
8	RI/+5V/+12V	IN/ PWR	+5V/+12V
9	GND	GND	

## 2.4.15 COM 3 RS-232 Pin Header (CN18)

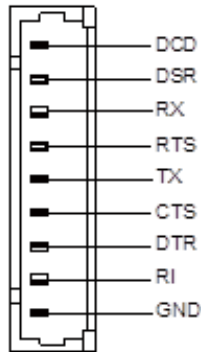

Pin	Pin Name	Signal Type	Signal Level
1	DCD	IN	
2	DSR	IN	
3	RX	IN	
4	RTS	OUT	±5V
5	TX	OUT	±5V
6	CTS	IN	
7	DTR	OUT	±5V
8	RI/+5V/+12V	IN/ PWR	+5V/+12V
9	GND	GND	

## 2.4.16 DIO Pin Header (CN24)

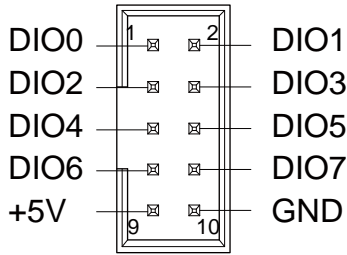

Pin	Pin Name	Signal Type	Signal Level
1	DIO0	I/O	+5V
2	DIO1	I/O	+5V
3	DIO2	I/O	+5V
4	DIO3	I/O	+5V
5	DIO4	I/O	+5V
6	DIO5	I/O	+5V
7	DIO6	I/O	+5V
8	DIO7	I/O	+5V
9	+5V	PWR	+5V
10	GND	GND	

**Note:** Digital I/O port supports current up to 0.5A.

## 2.4.17 COM 4 RS-232 Pin Header (CN26)

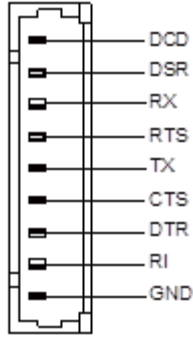

Pin	Pin Name	Signal Type	Signal Level
1	DCD	IN	
2	DSR	IN	
3	RX	IN	
4	RTS	OUT	±5V
5	TX	OUT	±5V
6	CTS	IN	
7	DTR	OUT	±5V
8	RI/+5V/+12V	IN/ PWR	+5V/+12V
9	GND	GND	

## 2.4.18 USB 3.0 Ports (CN21/CN22)

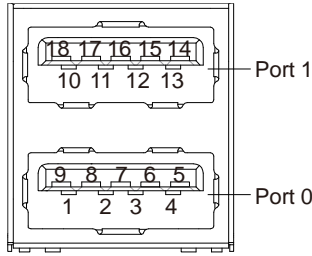

Pin	Pin Name	Signal Type	Signal Level
1	+5VSB	PWR	+5V
2	USB_D-	DIFF	
3	USB_D+	DIFF	
4	GND	GND	
5	USB_SSRX0-	DIFF	
6	USB_SSRX0+	DIFF	
7	GND	GND	
8	USB_SSTX0-	DIFF	
9	USB_SSTX0+	DIFF	
10	+5VSB	PWR	+5V
11	USB_D-	DIFF	
12	USB_D+	DIFF	
13	GND	GND	
14	USB_SSRX1-	DIFF	
15	USB_SSRX1+	DIFF	
16	GND	GND	
17	USB_SSTX1-	DIFF	
18	USB_SSTX1+	DIFF	

**Note:** USB 3.0 Ports support current up to 1A.

## 2.4.19 Mini Card Connector (CN11)

Pin	Pin Name	Signal Type	Signal Level
1	PCIE_WAKE#	IN	
2	+V3.3S	PWR	+3.3V
3	NC		
4	GND	GND	
5	NC		
6	+V1.5S	PWR	+1.5V
7	PCIE_CLK_REQ#	IN	
8	UIM_PWR	PWR	
9	GND	GND	
10	UIM_DATA	I/O	
11	PCIE_REF_CLK-	DIFF	
12	UIM_CLK	IN	
13	PCIE_REF_CLK+	DIFF	
14	UIM_RST	IN	
15	GND	GND	
16	UIM_VPP	PWR	
17	NC		
18	GND	GND	
19	NC		
20	W_DISABLE#	OUT	+3.3V
21	GND	GND	
22	PCIE_RST#	OUT	+3.3V
23	MSATA_RX-	DIFF	
24	+V3.3S	PWR	+3.3V

Pin	Pin Name	Signal Type	Signal Level
25	MSATA_RX+	DIFF	
26	GND	GND	
27	GND	GND	
28	+V1.5S	PWR	+1.5V
29	GND	GND	
30	SMB_CLK	I/O	+3.3V
31	MSATA_TX-	DIFF	
32	SMB_DATA	I/O	+3.3V
33	MSATA_TX+	DIFF	
34	GND	GND	
35	GND	GND	
36	USB_D-	DIFF	
37	GND	GND	
38	USB_D+	DIFF	
39	+V3.3S	PWR	+3.3V
40	GND	GND	
41	+V3.3S	PWR	+3.3V
42	NC		
43	GND	GND	
44	NC		
45	NC		
46	NC		
47	NC		
48	+V1.5S	PWR	+1.5V
49	NC		
50	GND	GND	

Pin	Pin Name	Signal Type	Signal Level
51	NC		
52	+3.3VSB	PWR	+3.3V

### 2.4.20 RJ-45 LAN (CN19/CN20)

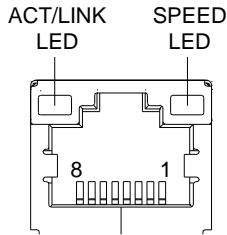

Pin	Pin Name	Signal Type	Signal level
1	MDI0+	DIFF	
2	MDI0-	DIFF	
3	MDI1+	DIFF	
4	MDI2+	DIFF	
5	MDI2-	DIFF	
6	MDI1-	DIFF	
7	MDI3+	DIFF	
8	MDI3-	DIFF	

### 2.4.21 HDMI Port (CN23)

Pin	Pin Name	Signal Type	Signal Level
1	HDMI_D2+	DIFF	
2	GND	GND	
3	HDMI_D2-	DIFF	



Pin	Pin Name	Signal Type	Signal Level
4	HDMI_D 1+	DIFF	
5	GND	GND	
6	HDMI_D 1-	DIFF	
7	HDMI_D0+	DIFF	
8	GND	GND	
9	HDMI_D0-	DIFF	
10	HDMI_CLK+	OUT	
11	GND	GND	
12	HDMI_CLK-	OUT	
13	NC		
14	NC		
15	HDMI_SCL	I/O	
16	HDMI_SDA	I/O	
17	GND	GND	
18	+V5S	PWR	+5V
19	HPD	IN	

### 2.4.22 VGA Port (CN25)

Pin	Pin Name	Signal Type	Signal Level
1	RED	OUT	
2	GREEN	OUT	
3	BLUE	OUT	
4	SPC	I/O	
5	GND	GND	
6	GND	GND	
7	GND	GND	

Pin	Pin Name	Signal Type	Signal Level
8	GND	GND	
9	+V5S	PWR	+5V
10	CRT_PLUG	IN	
11	SPD	I/O	
12	DDC_DAT	I/O	
13	HSYNC	OUT	
14	VSYNC	OUT	
15	DDC_CLK	I/O	

## 2.5 CPU Installation

---

Before beginning CPU installation, ensure the system is shut down (not in rest or sleep mode) and the power cord is disconnected. Have the Intel Kaby Lake or Skylake-S FCLGA 1151 processor ready (max. TDP 35W).



**Step 1:** Remove the plastic cover from the CPU socket as shown below.



**Step 2:** Place the CPU in the socket, lining up the tabs as shown.



**Step 3:** Place the bracket onto the standoffs. Make sure to align as shown.



**Step 4:** Slide the cover as shown to fit the bracket onto the standoffs.

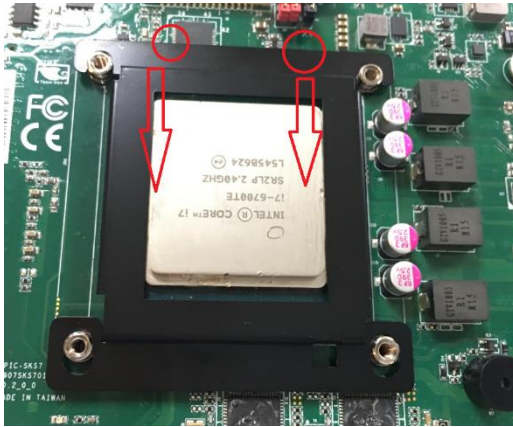

**Step 5:** Stick the sponge on the PCB in order to secure the metal cover.



Notes regarding the benefits of the bracket:

- **Special Surface Treatment:** The CPU bracket cover is treated with an electrophoretic deposition and insulation feature for better EMC protection.
- **More Secure CPU:** The bracket cover provides a more secure mount to hold CPU in place when disassembling cooler/thermal solution.
- **Better Thermal Performance:** The bracket cover provides the CPU with more heat spreading, allowing for better, more reliable performance.

# Chapter 3

---

BIOS Setup

## 3.1 System Test and Initialization

---

These routines test and initialize board hardware. If the routines encounter an error during the tests, you will either hear a few short beeps or see an error message on the screen. There are two kinds of errors: fatal and non-fatal. The system can usually continue the boot up sequence with non-fatal errors.

### System configuration verification

These routines check the current system configuration stored in the CMOS memory and BIOS NVRAM. If system configuration is not found or system configuration data error is detected, system will load optimized default and re-boot with this default system configuration automatically.

There are four situations in which you will need to setup system configuration:

1. You are starting your system for the first time
2. You have changed the hardware attached to your system
3. The system configuration is reset by Clear-CMOS jumper
4. The CMOS memory has lost power and the configuration information has been erased.

**The EPIC-KBS7 CMOS memory has an integral lithium battery backup for data retention. However, you will need to replace the complete unit when it finally runs down.**

## 3.2 AMI BIOS Setup

---

AMI BIOS ROM has a built-in Setup program that allows users to modify the basic system configuration. This type of information is stored in battery-backed CMOS RAM and BIOS NVRAM so that it retains the Setup information when the power is turned off.

### Entering Setup

Power on the computer and press <Del> or <ESC> immediately. This will allow you to enter Setup.

**Main** – Date and time can be set here. Press <Tab> to switch between date elements

**Advanced** – Access and configure advanced processor options and features.

**Chipset** – Chipset and host bridge options and features

**Boot** – Set boot options including boot priority and Quiet Boot option

**Security** – The setup administrator password can be set here

**Save & Exit** – Save your changes and exit the program



### 3.3 Setup Submenu: Main

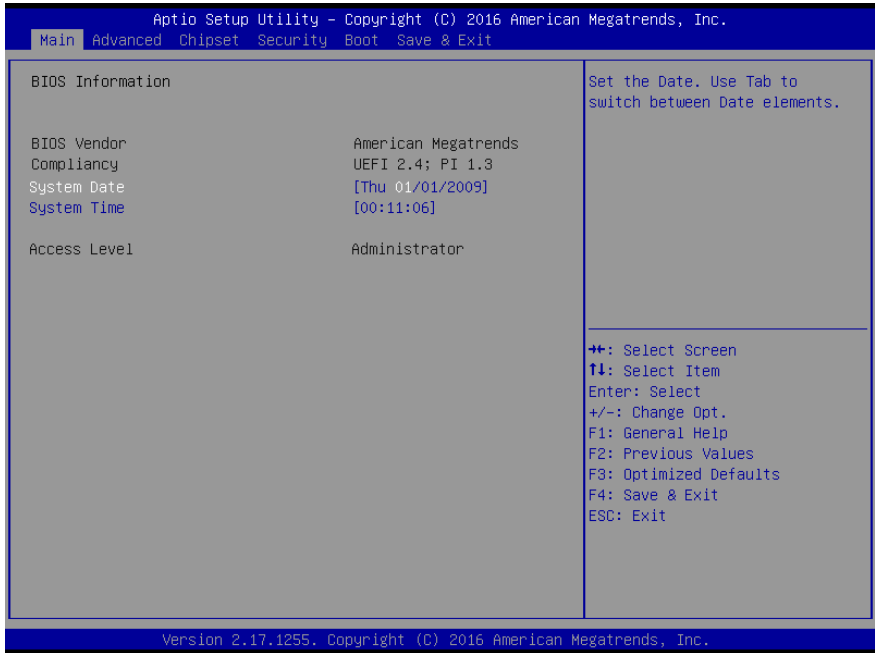

### 3.4 Setup Submenu: Advanced

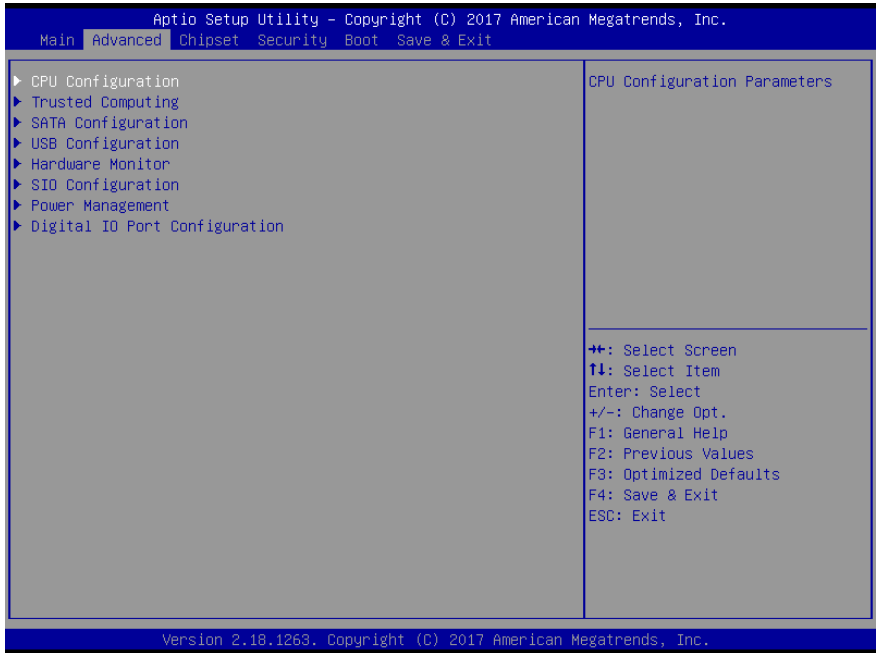

### 3.4.1 CPU Configuration

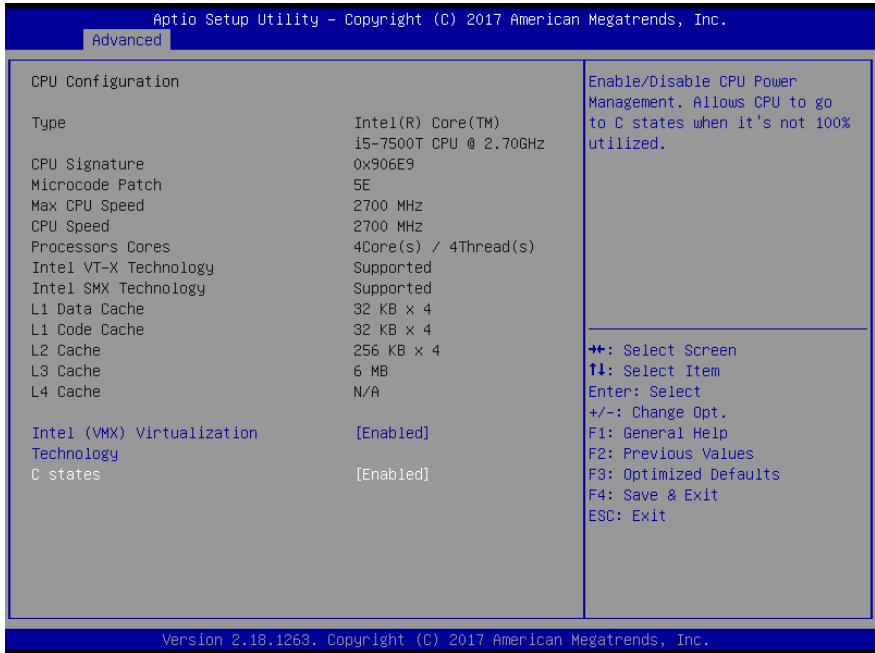

Options Summary		
Intel (VMX) Virtualization Technology	Disabled	
	Enabled	Optimal Default, Failsafe Default
When enabled, a VMM can utilize the additional hardware capabilities provided by Vanderpool Technology.		
C states	Disabled	
	Enabled	Optimal Default, Failsafe Default
Enabled for Windows XP and Linux (OS optimized for Hyper-Threading Technology) and Disable for other OS (OS not optimized for Hyper-Threading Technology). When Disabled only one thread per enabled core is enabled.		

### 3.4.2 SATA Configuration

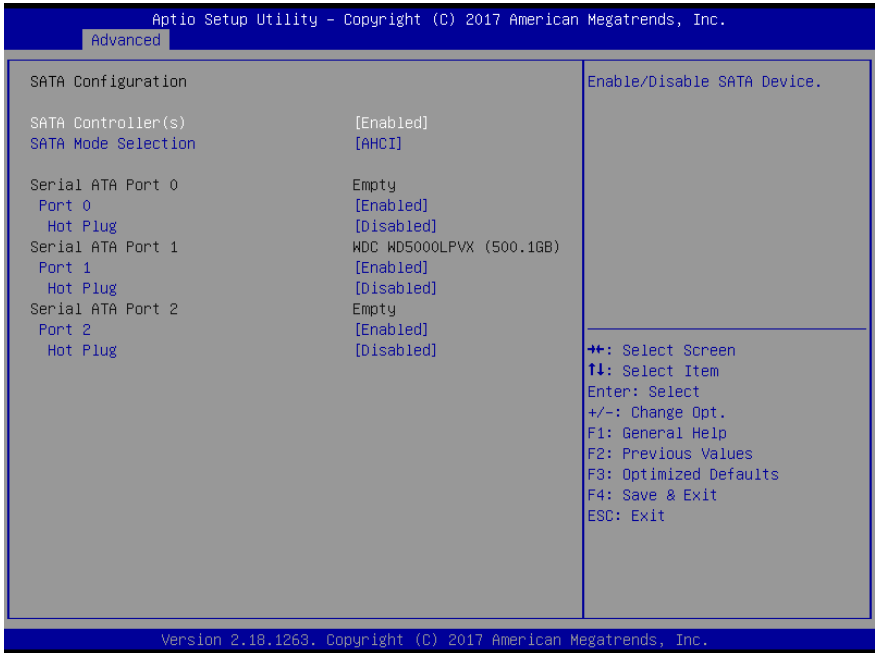

Options Summary		
SATA Controller(s)	Enabled	Optimal Default, Failsafe Default
	Disabled	
Enable or disable SATA Device.		
SATA Mode	AHCI Mode	Optimal Default, Failsafe Default
	RAID Mode	
Determines how SATA controller(s) operate.		
Port 0	Disabled	
	Enabled	Optimal Default, Failsafe Default
Enable or Disable SATA Port.		
Hot Plug	Disabled	Optimal Default, Failsafe Default
	Enabled	
Designates this port as Hot Pluggable.		

### 3.4.3 SIO Configuration

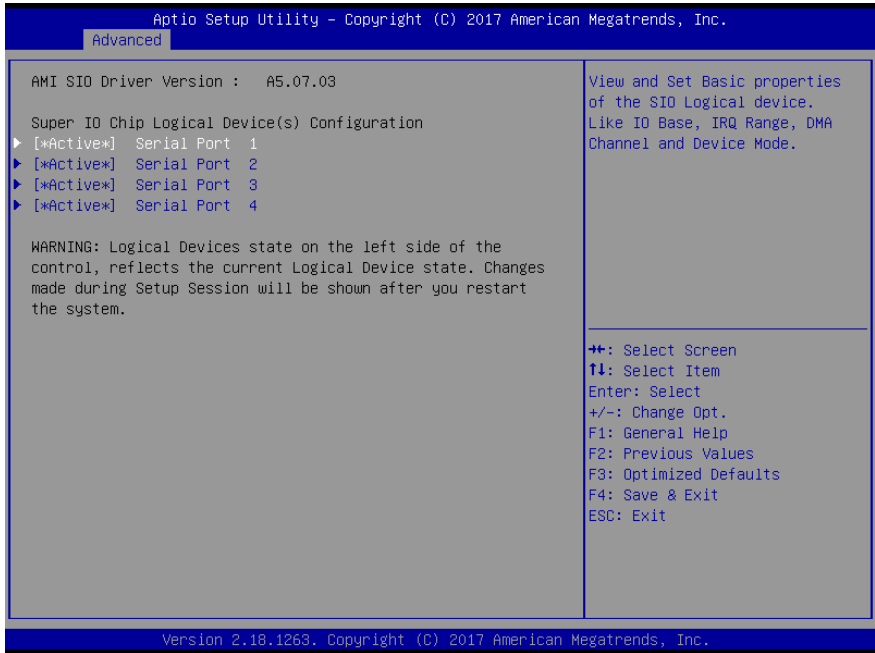

### 3.4.3.1 Serial Port Configuration

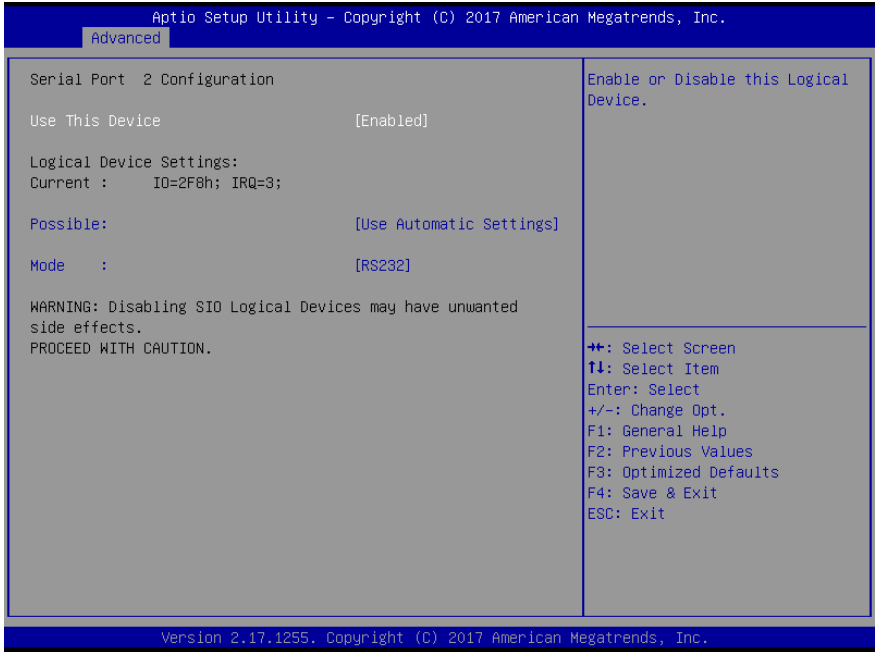

Options Summary		
Use This Device	Disabled	
	Enabled	Optimal Default, Failsafe Default
Enable or Disable Serial Port (COM).		
Possible:	Use Automatic Settings	Optimal Default, Failsafe Default
	IO=2F8; IRQ=3;	
	IO=3F8; IRQ=4;	
Select an optimal setting for IO device.		
mode	RS232	Optimal Default, Failsafe Default
	RS422	
	RS485	
UART RS232/422/485 selection.		

### 3.4.4 Hardware Monitor

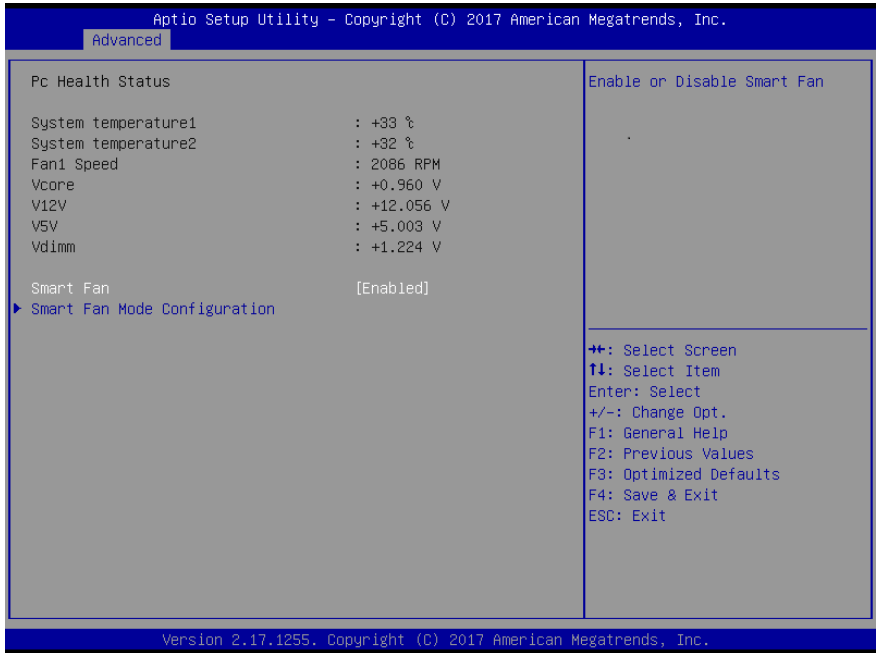

Options Summary		
Fan1 Smart Fan control	Manual RPM Mode	
	Manual Duty Mode	
	Auto RPM Mode	
	Auto Duty-Cycle Mode	Optimal Default, Failsafe Default

### 3.4.4.1 CPU Smart Fan Mode Configuration

#### Manual RPM Mode

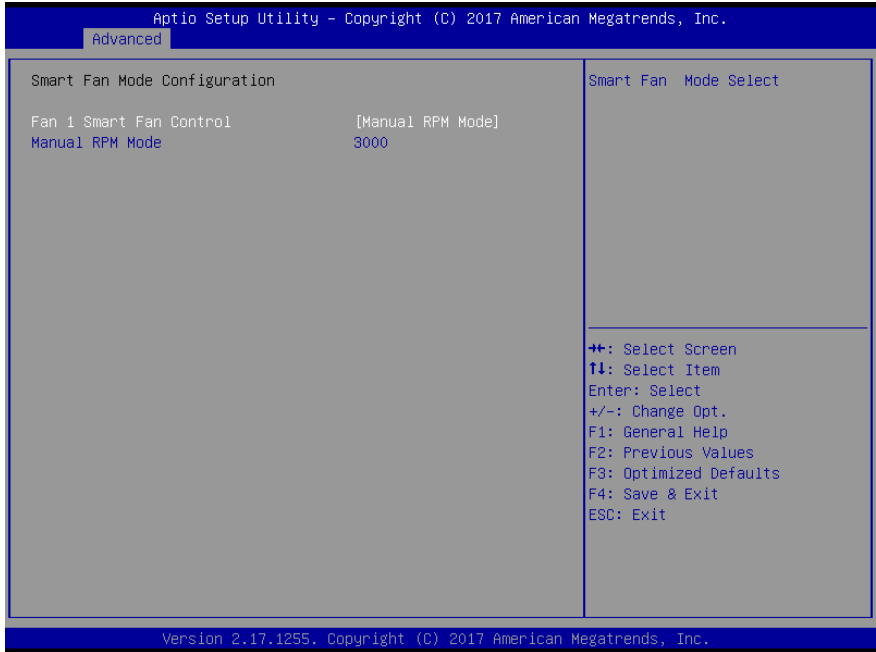

Options Summary		
Manual Setting	3000	Optimal Default, Failsafe Default
Set Fan at fixed RPM.		



## Manual Duty Mode



Options Summary		
Manual Setting	60	Optimal Default, Failsafe Default
Set Fan at fixed Duty-Cycle Min=0 Max=100 Please input Dec number.		

Aptio Setup Utility - Copyright (C) 2017 American Megatrends, Inc.

Advanced

<p>Smart Fan Mode Configuration</p> <pre> Fan 1 Smart Fan Control          [Auto RPM Mode] Temperature Source                [CPU(external)] Temperature 1                     60 Temperature 2                     50 Temperature 3                     40 Temperature 4                     30 RPM Percentage 1                  85 RPM Percentage 2                  70 RPM Percentage 3                  60 RPM Percentage 4                  50 RPM Percentage 5                  40                 </pre>	<p>Smart Fan Mode Select</p> <hr/> <pre> ++: Select Screen t↓: Select Item Enter: Select +/-: Change Opt. F1: General Help F2: Previous Values F3: Optimized Defaults F4: Save &amp; Exit ESC: Exit                 </pre>
--	--

Version 2.17.1255. Copyright (C) 2017 American Megatrends, Inc.

Aptio Setup Utility - Copyright (C) 2017 American Megatrends, Inc.

Advanced

<p>Smart Fan Mode Configuration</p> <pre> Fan 1 Smart Fan Control          [Auto RPM Mode] Temperature Source                [CPU(external)] Temperature 1                     60 Temperature 2                     50 Temperature 3                     40 Temperature 4                     30 RPM Percentage 1                  85 RPM Percentage 2                  70 RPM Percentage 3                  60 RPM Percentage 4                  50 RPM Percentage 5                  40                 </pre>	<p>Smart Fan Mode Select</p> <hr/> <pre> ++: Select Screen t↓: Select Item Enter: Select +/-: Change Opt. F1: General Help F2: Previous Values F3: Optimized Defaults F4: Save &amp; Exit ESC: Exit                 </pre>
--	--

Version 2.17.1255. Copyright (C) 2017 American Megatrends, Inc.

### 3.4.5 USB Configuration

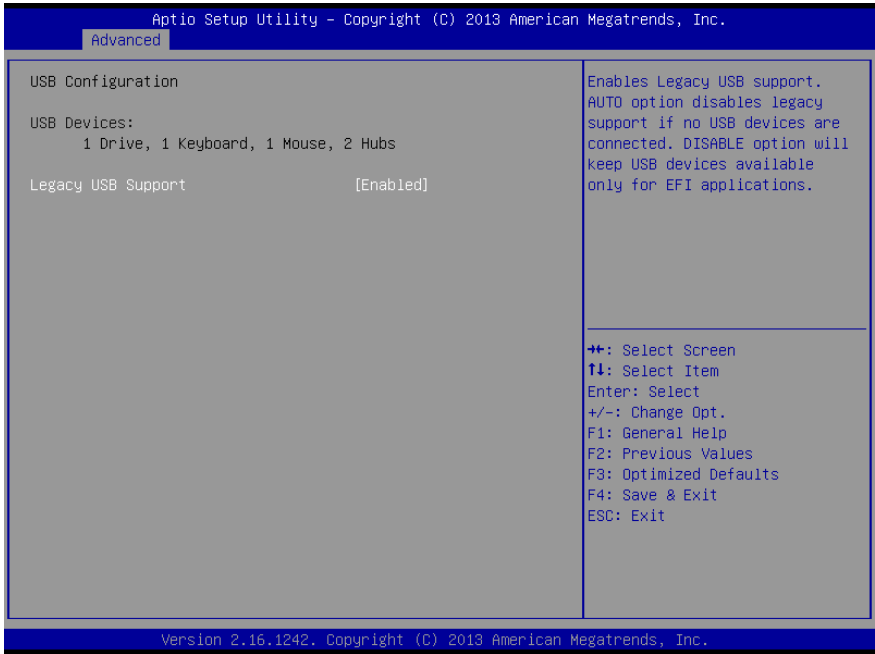

Options Summary		
Legacy USB Support	Enabled	Optimal Default, Failsafe Default
	Disabled	
	Auto	
Enables BIOS Support for Legacy USB Support. When enabled, USB can be functional in legacy environment like DOS. AUTO option disables legacy support if no USB devices are connected.		
Device Name (Emulation Type)	Auto	Optimal Default, Failsafe Default
	Floppy	
	Forced FDD	
	Hard Disk	
	CDROM	
If Auto. USB devices less than 530MB will be emulated as Floppy and remaining as Floppy and remaining as hard drive. Forced FDD option can be used to force an HDD formatted drive to boot as FDD (Ex. ZIP drive).		
USB Port 0/1 function routing	FCH USB port 8/9	Optimal Default, Failsafe Default
	FCH USB port 0/1	

### 3.4.6 Digital IO Port Configuration

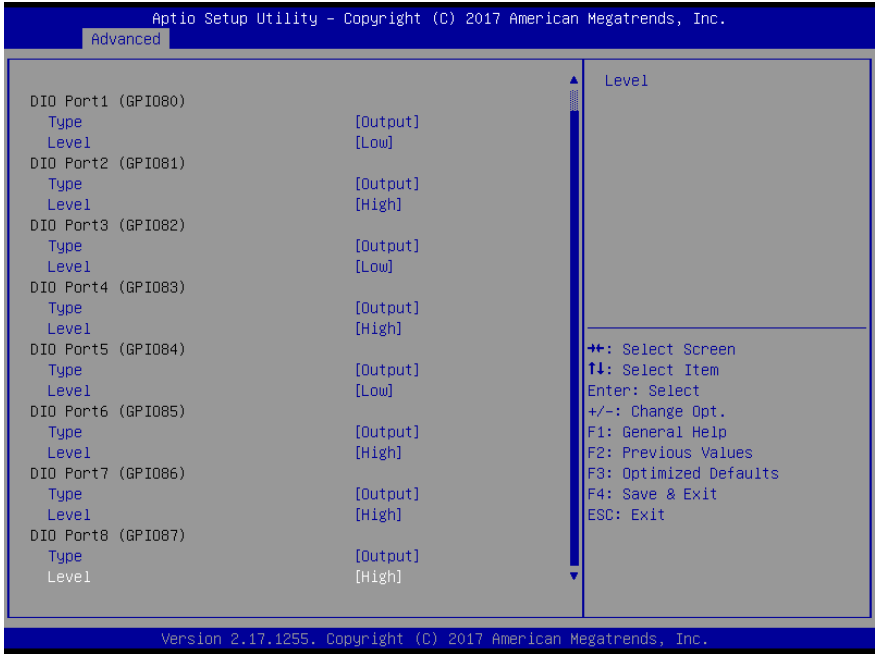

Options Summary		
DIO Port*	Output	
	Input	
Set DIO as Input or Output.		
Output Level	High	
	Low	
Set output level when DIO pin is output.		

### 3.4.7 Power Management

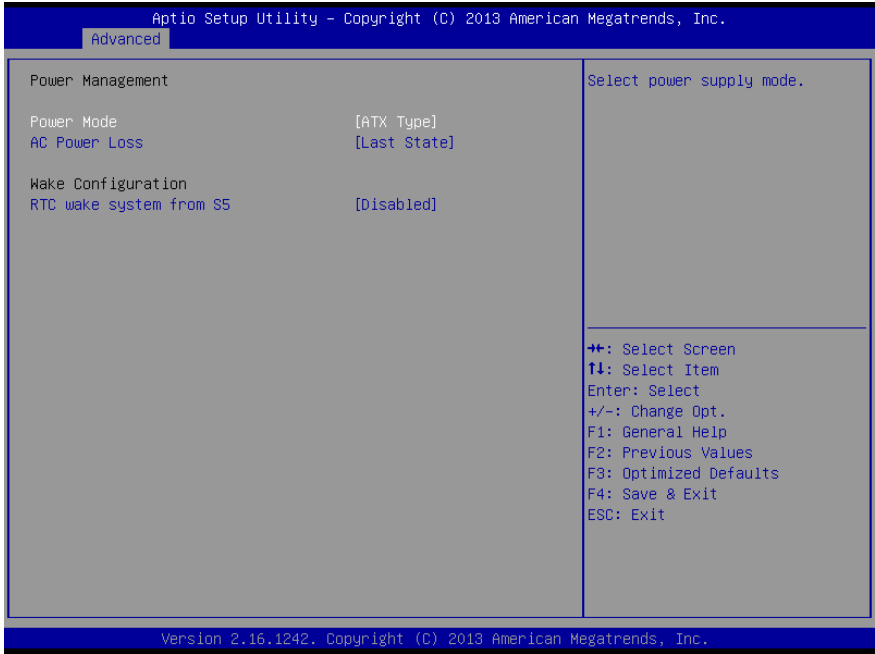

Options Summary		
Power Mode	ATX Type	Optimal Default, Failsafe Default
	AT Type	
Select power supply mode.		
Restore on Power Loss	Last State	Optimal Default, Failsafe Default
	Power On	
	Power Off	
Select power state when power is re-applied after a power failure.		
RTC wake system from S5	Disabled	Optimal Default, Failsafe Default
	Fixed Time	
	Dynamic Time	
Enable or disable System wake on alarm event. When enabled, System will wake on the hr::min::sec specified.		

### 3.5 Setup Submenu: Chipset

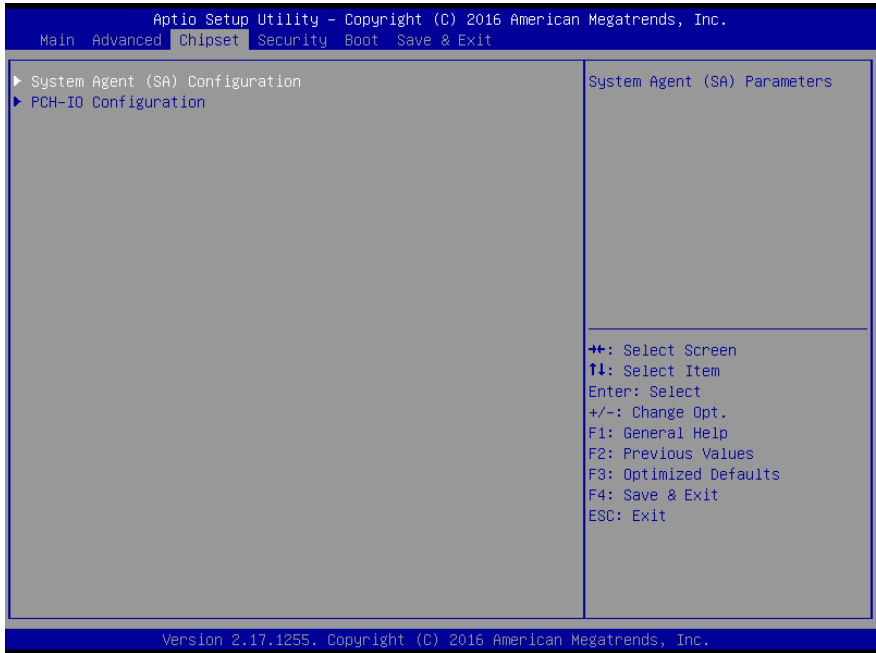

### 3.5.1 System Agent (SA) Configuration

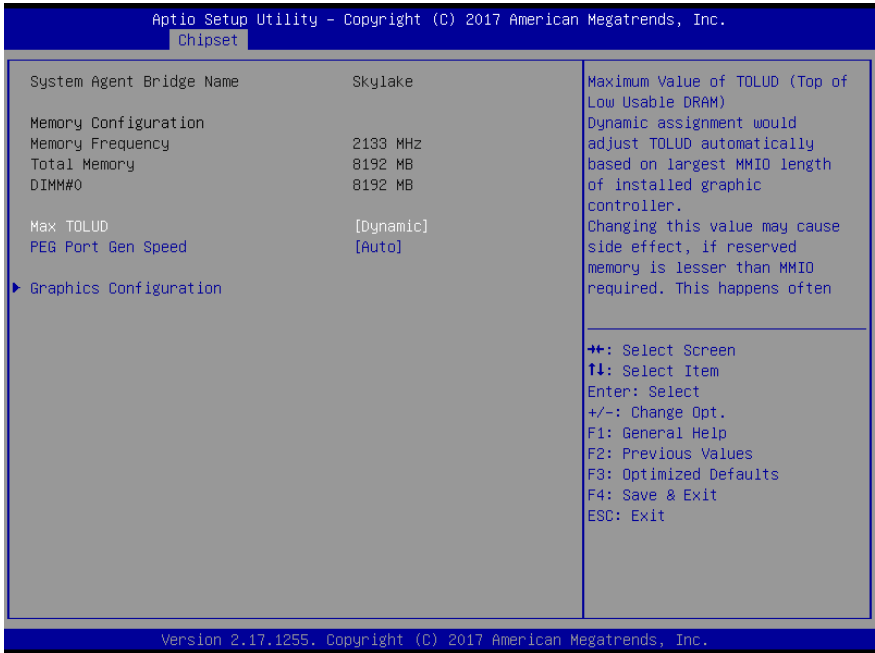

Options Summary		
Max TOLUD	Dynamic	Optimal Default, Failsafe Default
	1 GB	
	1.25 GB	
	1.5 GB	
	1.75 GB	
	2 GB	
	2.25 GB	
	2.5 GB	
	2.75 GB	
	3 GB	
3.25 GB		
Maximum Value of TOLUD Dynamic assignment would adjust TOLUD automatically based on largest MMIO length of installed graphic controller.		

Options Summary		
PEG Port Gen Speed	Auto	Optimal Default, Failsafe Default
	Gen1	
	Gen2	
	Gen3	
Configure PED 0:1:0 Max Speed.		

### 3.5.1.1 Graphics Configuration

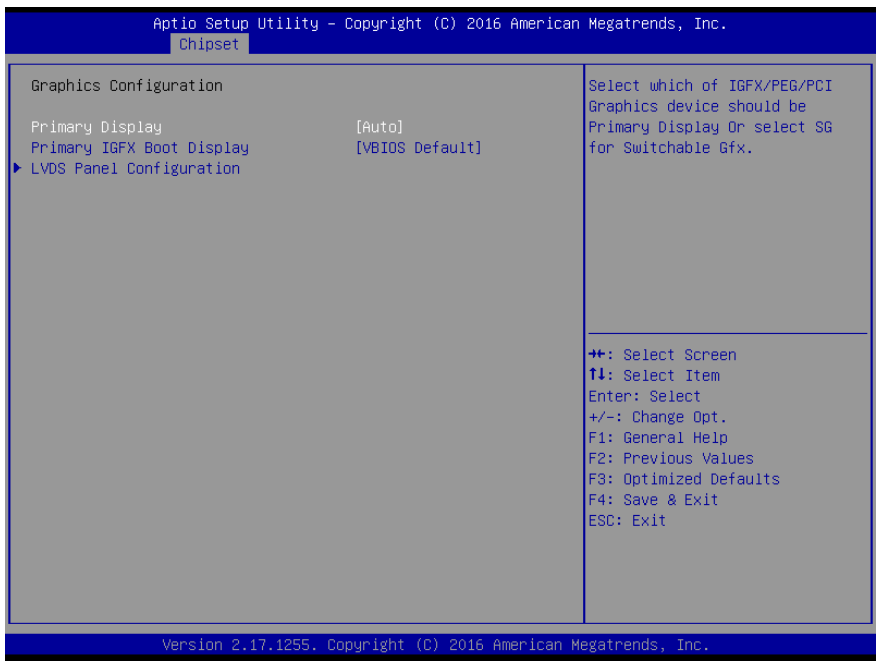

Options Summary		
Primary Display	Auto	Optimal Default, Failsafe Default
	IGFX	
	PEG	
	PCIE	
Select which of IGFX/PEG Graphics device should be Primary Display.		
Primary IGFX Boot Display	vBIOS Default	Optimal Default, Failsafe Default
	CRT	



Options Summary		
	LVDS	
	HDMI	
Select the Video Device which will be activated during POST. This has no effect if external graphic present. Secondary boot display selection will appear based on your selection.		
<b>Secondary IGFX Boot Display</b>	Disabled	Optimal Default, Failsafe Default
	CRT	
	HDMI	
Select Secondary Display Device.		

### 3.5.1.2 LVDS Panel Configuration

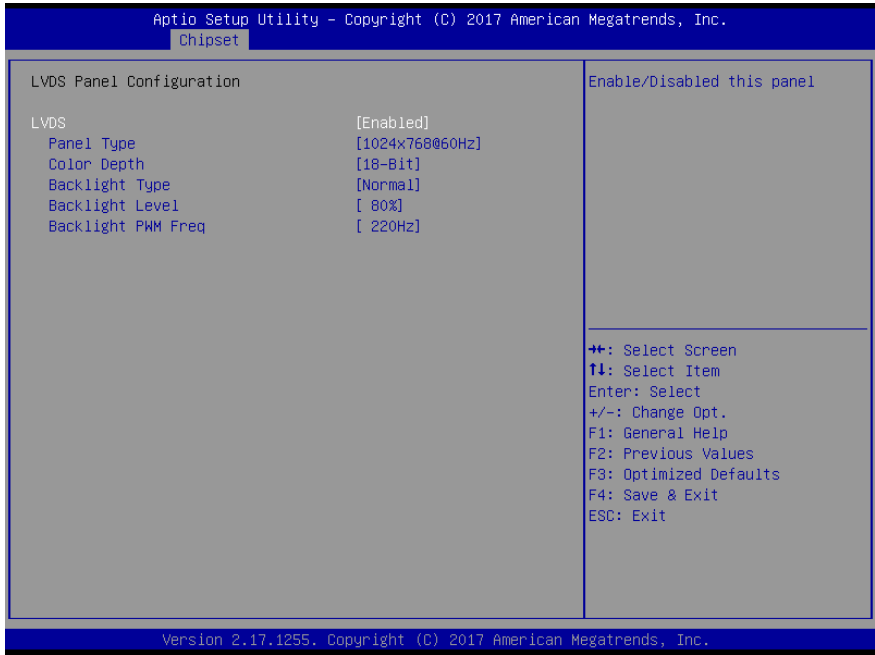

Options Summary		
LVDS	Disabled	
	Enabled	Optimal Default, Failsafe Default
Enable/Disabled this panel.		
LVDS Panel Type	640x480@60Hz	
	800x480@60Hz	
	800x600@60Hz	
	1024x600@60Hz	
	1024x768@60Hz	Optimal Default, Failsafe Default
	1280x768@60Hz	
	1280x800@60Hz	
	1280x1024@60Hz	
	1366x768@60Hz	
	1440x900@60Hz	
	1600x1200@60Hz	
	1920x1080@60Hz	

Options Summary		
	1920x1200@60Hz	
Select LCD panel used by Internal Graphics Device by selecting the appropriate setup item.		
Color Depth	18-bit	Optimal Default, Failsafe Default
	24-bit	
	36-bit	
	48-bit	
Select panel type.		
Backlight Type	Normal	Optimal Default, Failsafe Default
	Inverted	
Select backlight control signal type.		
Backlight Level	0%	
	10%	
	20%	
	30%	
	40%	
	50%	
	60%	
	70%	
	80%	Optimal Default, Failsafe Default
	90%	
100%		
Select backlight control level.		
Backlight PWM Freq	100Hz	
	200Hz	
	220Hz	Optimal Default, Failsafe Default
	500Hz	
	1KHz	
	2.2KHz	
	6.5KHz	
Select PWM frequency of backlight control signal.		

## 3.5.2 PCH-IO Configuration

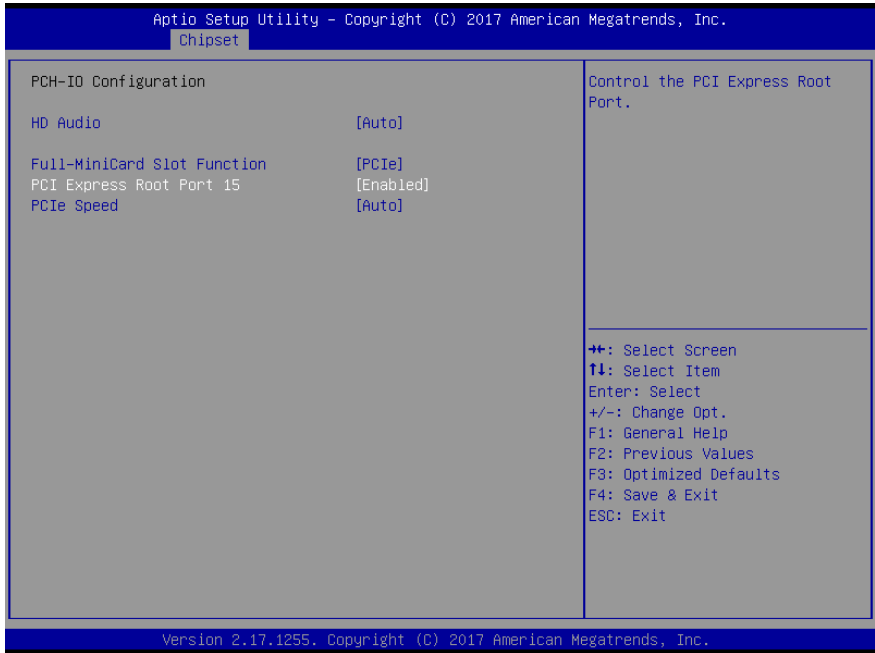

Options Summary		
Full-MiniCard Slot Function	SATA	Optimal Default, Failsafe Default
	PCIe	
Switch minicard slot function (Excluding H110 SKU).		
PCI Express Root Port 15	Disabled	
	Enabled	Optimal Default, Failsafe Default
Control the PCIe root port.		
PCIe Speed	Auto	Optimal Default, Failsafe Default
	Gen1	
	Gen2	
	Gen3	
Select PCI Express port speed.		

## 3.6 Setup Submenu: Security

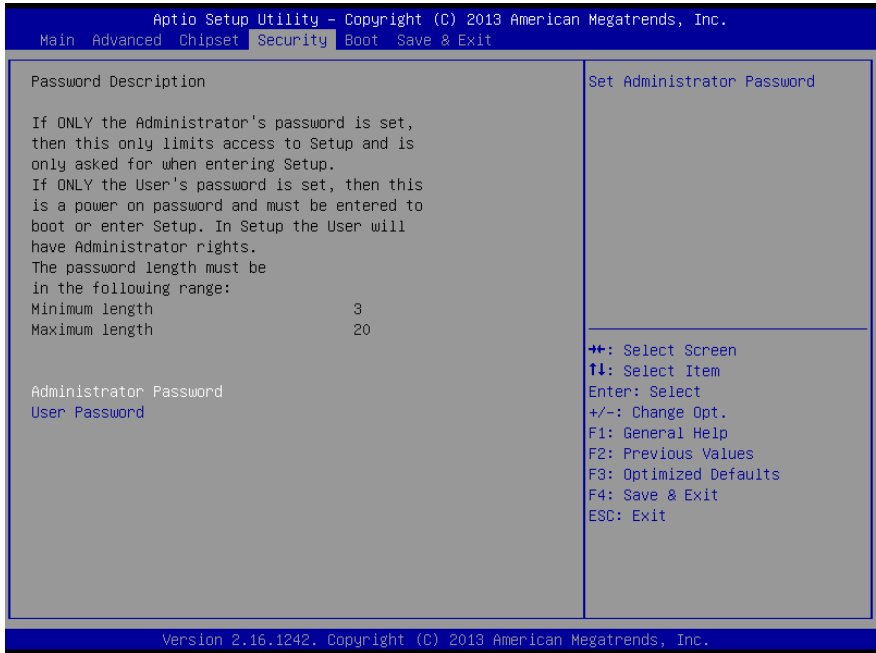

### Change User/Administrator Password

You can set an Administrator Password or User Password. An Administrator Password must be set before you can set a User Password. The password will be required during boot up, or when the user enters the Setup utility. A User Password does not provide access to many of the features in the Setup utility.

Select the password you wish to set, and press Enter. In the dialog box, enter your password (must be between 3 and 20 letters or numbers). Press Enter and retype your password to confirm. Press Enter again to set the password.

### Removing the Password

Select the password you want to remove and enter the current password. At the next dialog box press Enter to disable password protection.

### 3.7 Setup Submenu: Boot

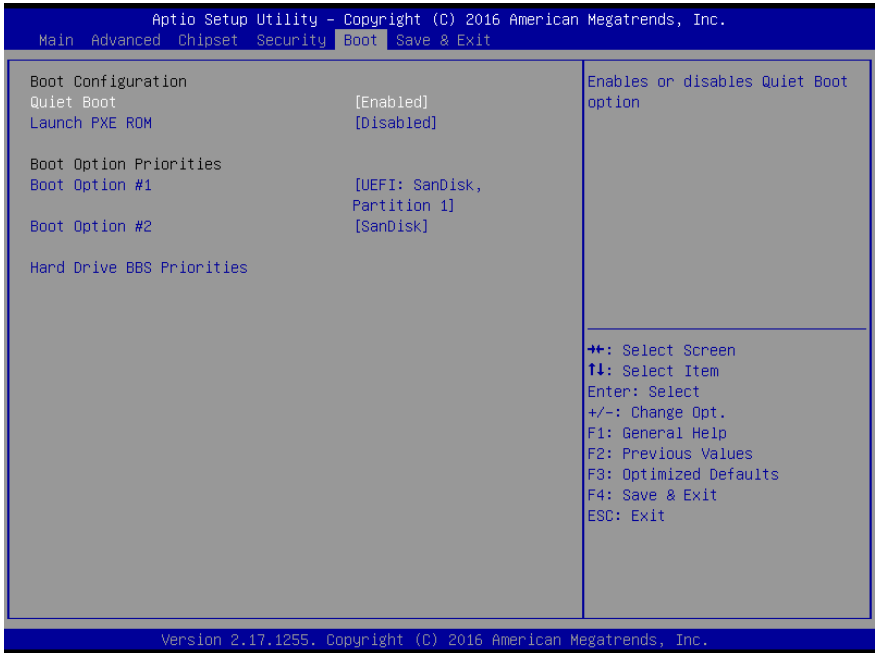

Options Summary		
Quiet Boot	Disabled	
	Enabled	Optimal Default, Failsafe Default
En/Disable showing boot logo.		
Launch PXE OpROM	Disabled	Optimal Default, Failsafe Default
	Enabled	
Controls the execution of UEFI and Legacy PXE OpROM.		

### 3.7.1 BBS Priorities

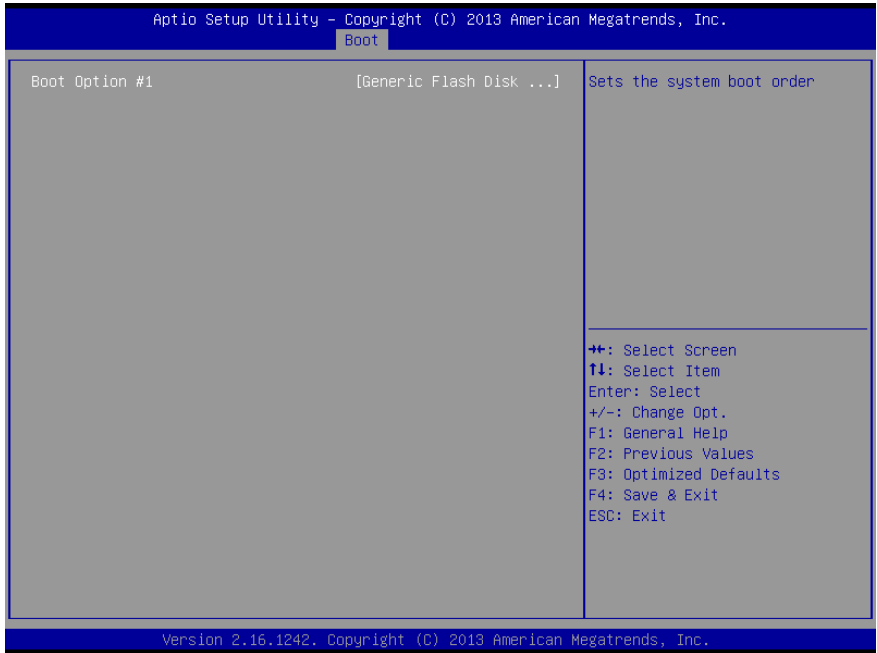

### 3.8 Setup Submenu: Save & Exit

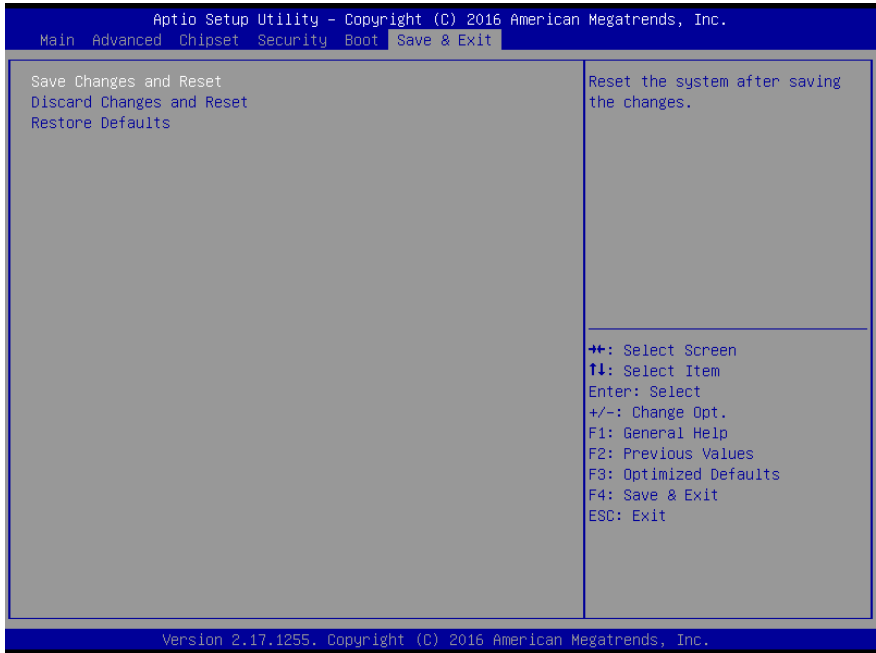



# Chapter 4

---

Drivers Installation

## 4.1 Driver Installation

---

Drivers for the EPIC-KBS7 can be downloaded from the product page on the AAEON website by following this link:

<https://www.aaeon.com/en/p/epic-boards-epic-kbs7>

Download the driver(s) you need and follow the steps below to install them.

### Install Chipset Drivers

1. Open the **Chipset Driver** folder
2. Open the **SetupChipset.exe** file in the folder
3. Follow the instructions
4. Drivers will be installed automatically

### Install Graphics Driver

1. Open the **Graphic Driver** folder and select your OS
2. Open the **Setup.exe** file in the folder
3. Follow the instructions
4. Drivers will be installed automatically

#### Note 1:

- This motherboard supports VGA and LVDS display devices. In Single Display mode. By default, press **<Ctrl>+<Alt>+<F1>** to switch to VGA device and press **<Ctrl>+<Alt>+<F3>** to switch to LVDS device.
- Before removing the current display device, connect the display device that you want to use, and then press the hot keys to switch to that device.

**Note 2:** If you are using Windows® XP, you have to install the driver of dotNet Framework first (**dotnetfx35.exe** in **dotNet Framework** folder).

### Install LAN Driver

1. Open the **LAN Driver** folder
2. Open the **PROWinx64\_20\_2.exe** file in the folder
3. Follow the instructions
4. Drivers will be installed automatically

### Install Audio Driver

1. Open the **Audio Driver** folder
2. Open the **Setup.exe** file in the folder
3. Follow the instructions
4. Drivers will be installed automatically

### Install COM Port Driver

1. Open the **COM Port Driver** folder
2. Open the **FintekSerial.exe** file in the folder
3. Follow the instructions
4. Drivers will be installed automatically

### Install Peripheral Drivers

1. Open **Linux Driver-Peripheral** folder and select your OS
2. Follow the instructions provided in the installation guidance to manually install drivers

# Appendix A

---



































I/O Information

## A.1 I/O Address Map

DESKTOP-282073Q



































Input/output (IO)

[0000000000000000 - 000000000000CF7]	PCI Express Root Complex
[0000000000000020 - 0000000000000021]	Programmable interrupt controller
[0000000000000024 - 0000000000000025]	Programmable interrupt controller
[0000000000000028 - 0000000000000029]	Programmable interrupt controller
[000000000000002C - 000000000000002D]	Programmable interrupt controller
[000000000000002E - 000000000000002F]	Motherboard resources
[0000000000000030 - 0000000000000031]	Programmable interrupt controller
[0000000000000034 - 0000000000000035]	Programmable interrupt controller
[0000000000000038 - 0000000000000039]	Programmable interrupt controller
[000000000000003C - 000000000000003D]	Programmable interrupt controller
[0000000000000040 - 0000000000000043]	System timer
[000000000000004E - 000000000000004F]	Motherboard resources
[0000000000000050 - 0000000000000053]	System timer
[0000000000000060 - 0000000000000060]	Standard PS/2 Keyboard
[0000000000000061 - 0000000000000061]	Motherboard resources
[0000000000000063 - 0000000000000063]	Motherboard resources
[0000000000000064 - 0000000000000064]	Standard PS/2 Keyboard
[0000000000000065 - 0000000000000065]	Motherboard resources
[0000000000000067 - 0000000000000067]	Motherboard resources
[0000000000000070 - 0000000000000070]	Motherboard resources
[0000000000000070 - 0000000000000077]	System CMOS/real time clock
[0000000000000080 - 0000000000000080]	Motherboard resources
[0000000000000092 - 0000000000000092]	Motherboard resources
[00000000000000A0 - 00000000000000A1]	Programmable interrupt controller
[00000000000000A4 - 00000000000000A5]	Programmable interrupt controller
[00000000000000A8 - 00000000000000A9]	Programmable interrupt controller
[00000000000000AC - 00000000000000AD]	Programmable interrupt controller
[00000000000000B0 - 00000000000000B1]	Programmable interrupt controller
[00000000000000B2 - 00000000000000B3]	Motherboard resources
[00000000000000B4 - 00000000000000B5]	Programmable interrupt controller
[00000000000000B8 - 00000000000000B9]	Programmable interrupt controller
[00000000000000BC - 00000000000000BD]	Programmable interrupt controller
[00000000000000F0 - 00000000000000F0]	Numeric data processor

	[0000000000000F0 - 0000000000000F0]	Numeric data processor
	[0000000000002E8 - 0000000000002EF]	Communications Port (COM4)
	[0000000000002F8 - 0000000000002FF]	Communications Port (COM2)
	[0000000000003B0 - 0000000000003BB]	Intel(R) HD Graphics 630
	[0000000000003C0 - 0000000000003DF]	Intel(R) HD Graphics 630
	[0000000000003E8 - 0000000000003EF]	Communications Port (COM3)
	[0000000000003F8 - 0000000000003FF]	Communications Port (COM1)
	[0000000000004D0 - 0000000000004D1]	Programmable interrupt controller
	[000000000000680 - 00000000000069F]	Motherboard resources
	[000000000000800 - 00000000000087F]	Motherboard resources
	[000000000000A00 - 000000000000A0F]	Motherboard resources
	[000000000000A10 - 000000000000A1F]	Motherboard resources
	[000000000000A20 - 000000000000A2F]	Motherboard resources
	[000000000000D00 - 000000000000FFFF]	PCI Express Root Complex
	[000000000000164E - 000000000000164F]	Motherboard resources
	[0000000000001800 - 00000000000018FE]	Motherboard resources
	[0000000000001854 - 0000000000001857]	Motherboard resources
	[000000000000D000 - 000000000000DFFF]	Intel(R) 100 Series/C230 Series Chipset Family PCI Express Root Port #7 - A116
	[000000000000E000 - 000000000000EFFF]	Intel(R) 100 Series/C230 Series Chipset Family PCI Express Root Port #6 - A115
	[000000000000F000 - 000000000000F03F]	Intel(R) HD Graphics 630
	[000000000000F040 - 000000000000F05F]	Intel(R) 100 Series/C230 Series Chipset Family SMBus - A123
	[000000000000F060 - 000000000000F07F]	Standard SATA AHCI Controller
	[000000000000F080 - 000000000000F083]	Standard SATA AHCI Controller
	[000000000000F090 - 000000000000F097]	Standard SATA AHCI Controller
	[000000000000FF00 - 000000000000FFFF]	Motherboard resources
	[000000000000FFFF - 000000000000FFFF]	Motherboard resources
	[000000000000FFFF - 000000000000FFFF]	Motherboard resources
	[000000000000FFFF - 000000000000FFFF]	Motherboard resources
	[000000000000FFFF - 000000000000FFFF]	Motherboard resources
>	Interrupt request (IRQ)	
∨	Memory	
	[000000000000A0000 - 000000000000BFFFF]	Intel(R) HD Graphics 630
	[000000000000A0000 - 000000000000BFFFF]	PCI Express Root Complex
	[00000000000000000 - 00000000000000000]	PCI Express Root Complex
	[00000000000000000 - 00000000000000000]	Intel(R) HD Graphics 630
	[00000000000000000 - 00000000000000000]	Intel(R) HD Graphics 630

## A.2 Memory Address Map

Address Range	Device Name
[00000000000A0000 - 00000000000BFFFFF]	Intel(R) HD Graphics 630
[00000000000A0000 - 00000000000BFFFFF]	PCI Express Root Complex
[0000000090000000 - 00000000DFFFFFFF]	PCI Express Root Complex
[00000000C0000000 - 00000000CFFFFFFF]	Intel(R) HD Graphics 630
[00000000DE000000 - 00000000DEFFFFFFF]	Intel(R) HD Graphics 630
[00000000DF000000 - 00000000DF01FFFFF]	Intel(R) I211 Gigabit Network Connection
[00000000DF000000 - 00000000DF0FFFFF]	Intel(R) 100 Series/C230 Series Chipset Family PCI Express Root Port #7 - A116
[00000000DF020000 - 00000000DF023FFF]	Intel(R) I211 Gigabit Network Connection
[00000000DF100000 - 00000000DF11FFFFF]	Intel(R) I211 Gigabit Network Connection #2
[00000000DF100000 - 00000000DF1FFFFF]	Intel(R) 100 Series/C230 Series Chipset Family PCI Express Root Port #6 - A115
[00000000DF120000 - 00000000DF123FFF]	Intel(R) I211 Gigabit Network Connection #2
[00000000DF200000 - 00000000DF20FFFFF]	High Definition Audio Controller
[00000000DF210000 - 00000000DF21FFFFF]	Intel(R) USB 3.0 eXtensible Host Controller - 1.0 (Microsoft)
[00000000DF220000 - 00000000DF223FFF]	High Definition Audio Controller
[00000000DF224000 - 00000000DF227FFF]	Intel(R) 100 Series/C230 Series Chipset Family PMC - A121
[00000000DF228000 - 00000000DF229FFF]	Standard SATA AHCI Controller
[00000000DF22A000 - 00000000DF22A0FFF]	Intel(R) 100 Series/C230 Series Chipset Family SMBus - A123
[00000000DF22B000 - 00000000DF22B7FFF]	Standard SATA AHCI Controller
[00000000DF22C000 - 00000000DF22C0FFF]	Standard SATA AHCI Controller
[00000000DF22D000 - 00000000DF22DFFF]	Intel(R) 100 Series/C230 Series Chipset Family Thermal subsystem - A131
[00000000DFFE0000 - 00000000DFFFFFFF]	Motherboard resources
[00000000E0000000 - 00000000EFFFFFFF]	Motherboard resources
[00000000FD000000 - 00000000FDABFFFFF]	Motherboard resources
[00000000FD000000 - 00000000FE77FFFFF]	PCI Express Root Complex
[00000000FDAC0000 - 00000000FDACFFFFF]	Motherboard resources
[00000000FDAD0000 - 00000000FDADFFFFF]	Motherboard resources
[00000000FDAE0000 - 00000000FDAEFFFFF]	Motherboard resources
[00000000FDAF0000 - 00000000FDAFFFFF]	Motherboard resources
[00000000FDB00000 - 00000000FDBFFFFF]	Motherboard resources
[00000000FE000000 - 00000000FE01FFFFF]	Motherboard resources
[00000000FE036000 - 00000000FE03BFFFF]	Motherboard resources
[00000000FE03D000 - 00000000FE33FFFFF]	Motherboard resources
[00000000FE410000 - 00000000FE77FFFFF]	Motherboard resources
[00000000FED00000 - 00000000FED003FFF]	High precision event timer

	(ISA) 0x000001F3 (499)	Microsoft ACPI-Compliant System
	(ISA) 0x000001F4 (500)	Microsoft ACPI-Compliant System
	(ISA) 0x000001F5 (501)	Microsoft ACPI-Compliant System
	(ISA) 0x000001F6 (502)	Microsoft ACPI-Compliant System
	(ISA) 0x000001F7 (503)	Microsoft ACPI-Compliant System
	(ISA) 0x000001F8 (504)	Microsoft ACPI-Compliant System
	(ISA) 0x000001F9 (505)	Microsoft ACPI-Compliant System
	(ISA) 0x000001FA (506)	Microsoft ACPI-Compliant System
	(ISA) 0x000001FB (507)	Microsoft ACPI-Compliant System
	(ISA) 0x000001FC (508)	Microsoft ACPI-Compliant System
	(ISA) 0x000001FD (509)	Microsoft ACPI-Compliant System
	(ISA) 0x000001FE (510)	Microsoft ACPI-Compliant System
	(ISA) 0x000001FF (511)	Microsoft ACPI-Compliant System
	(PCI) 0x00000005 (05)	Intel(R) 100 Series/C230 Series Chipset Family SMBus - A123
	(PCI) 0x00000006 (06)	Intel(R) 100 Series/C230 Series Chipset Family Thermal subsystem - A131
	(PCI) 0x00000010 (16)	High Definition Audio Controller
	(PCI) 0xFFFFFEE (-18)	Intel(R) I211 Gigabit Network Connection #2
	(PCI) 0xFFFFFEF (-17)	Intel(R) I211 Gigabit Network Connection #2
	(PCI) 0xFFFFF0 (-16)	Intel(R) I211 Gigabit Network Connection #2
	(PCI) 0xFFFFF1 (-15)	Intel(R) I211 Gigabit Network Connection
	(PCI) 0xFFFFF2 (-14)	Intel(R) I211 Gigabit Network Connection
	(PCI) 0xFFFFF3 (-13)	Intel(R) I211 Gigabit Network Connection
	(PCI) 0xFFFFF4 (-12)	Intel(R) I211 Gigabit Network Connection
	(PCI) 0xFFFFF5 (-11)	Intel(R) I211 Gigabit Network Connection
	(PCI) 0xFFFFF6 (-10)	Intel(R) I211 Gigabit Network Connection
	(PCI) 0xFFFFF7 (-9)	Intel(R) I211 Gigabit Network Connection #2
	(PCI) 0xFFFFF8 (-8)	Intel(R) I211 Gigabit Network Connection #2
	(PCI) 0xFFFFF9 (-7)	Intel(R) I211 Gigabit Network Connection #2
	(PCI) 0xFFFFFA (-6)	Intel(R) USB 3.0 eXtensible Host Controller - 1.0 (Microsoft)
	(PCI) 0xFFFFFB (-5)	Intel(R) HD Graphics 630
	(PCI) 0xFFFFFC (-4)	Standard SATA AHCI Controller
	(PCI) 0xFFFFFD (-3)	Intel(R) 100 Series/C230 Series Chipset Family PCI Express Root Port #7 - A116
	(PCI) 0xFFFFFE (-2)	Intel(R) 100 Series/C230 Series Chipset Family PCI Express Root Port #6 - A115
>		Memory





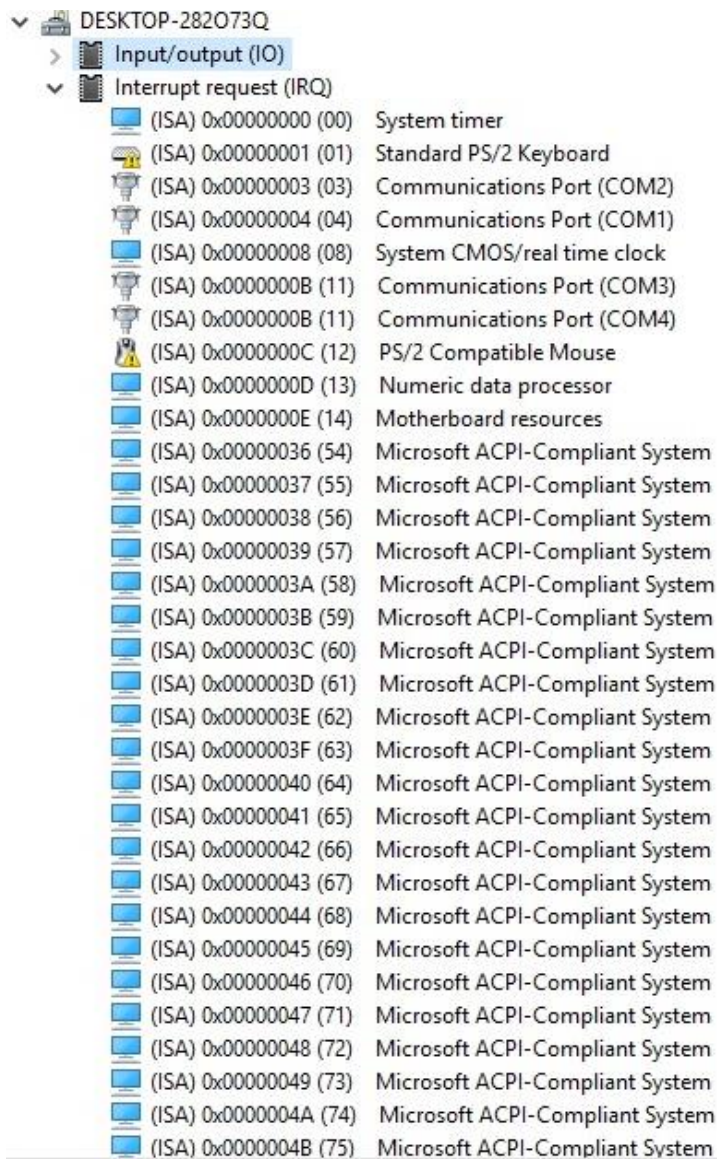





























## A.3 IRQ Mapping Chart



The screenshot shows the Windows Device Manager for a system named 'DESKTOP-282073Q'. The 'Input/output (IO)' category is expanded, and the 'Interrupt request (IRQ)' category is also expanded. A list of 27 IRQs is shown, each with a corresponding icon and a description. The IRQs range from 00 to 75. IRQs 00 through 14 are assigned to various hardware components, while IRQs 15 through 75 are assigned to 'Microsoft ACPI-Compliant System'.

IRQ	Device
(ISA) 0x00000000 (00)	System timer
(ISA) 0x00000001 (01)	Standard PS/2 Keyboard
(ISA) 0x00000003 (03)	Communications Port (COM2)
(ISA) 0x00000004 (04)	Communications Port (COM1)
(ISA) 0x00000008 (08)	System CMOS/real time clock
(ISA) 0x0000000B (11)	Communications Port (COM3)
(ISA) 0x0000000B (11)	Communications Port (COM4)
(ISA) 0x0000000C (12)	PS/2 Compatible Mouse
(ISA) 0x0000000D (13)	Numeric data processor
(ISA) 0x0000000E (14)	Motherboard resources
(ISA) 0x00000036 (54)	Microsoft ACPI-Compliant System
(ISA) 0x00000037 (55)	Microsoft ACPI-Compliant System
(ISA) 0x00000038 (56)	Microsoft ACPI-Compliant System
(ISA) 0x00000039 (57)	Microsoft ACPI-Compliant System
(ISA) 0x0000003A (58)	Microsoft ACPI-Compliant System
(ISA) 0x0000003B (59)	Microsoft ACPI-Compliant System
(ISA) 0x0000003C (60)	Microsoft ACPI-Compliant System
(ISA) 0x0000003D (61)	Microsoft ACPI-Compliant System
(ISA) 0x0000003E (62)	Microsoft ACPI-Compliant System
(ISA) 0x0000003F (63)	Microsoft ACPI-Compliant System
(ISA) 0x00000040 (64)	Microsoft ACPI-Compliant System
(ISA) 0x00000041 (65)	Microsoft ACPI-Compliant System
(ISA) 0x00000042 (66)	Microsoft ACPI-Compliant System
(ISA) 0x00000043 (67)	Microsoft ACPI-Compliant System
(ISA) 0x00000044 (68)	Microsoft ACPI-Compliant System
(ISA) 0x00000045 (69)	Microsoft ACPI-Compliant System
(ISA) 0x00000046 (70)	Microsoft ACPI-Compliant System
(ISA) 0x00000047 (71)	Microsoft ACPI-Compliant System
(ISA) 0x00000048 (72)	Microsoft ACPI-Compliant System
(ISA) 0x00000049 (73)	Microsoft ACPI-Compliant System
(ISA) 0x0000004A (74)	Microsoft ACPI-Compliant System
(ISA) 0x0000004B (75)	Microsoft ACPI-Compliant System

	(ISA) 0x000001F3 (499)	Microsoft ACPI-Compliant System
	(ISA) 0x000001F4 (500)	Microsoft ACPI-Compliant System
	(ISA) 0x000001F5 (501)	Microsoft ACPI-Compliant System
	(ISA) 0x000001F6 (502)	Microsoft ACPI-Compliant System
	(ISA) 0x000001F7 (503)	Microsoft ACPI-Compliant System
	(ISA) 0x000001F8 (504)	Microsoft ACPI-Compliant System
	(ISA) 0x000001F9 (505)	Microsoft ACPI-Compliant System
	(ISA) 0x000001FA (506)	Microsoft ACPI-Compliant System
	(ISA) 0x000001FB (507)	Microsoft ACPI-Compliant System
	(ISA) 0x000001FC (508)	Microsoft ACPI-Compliant System
	(ISA) 0x000001FD (509)	Microsoft ACPI-Compliant System
	(ISA) 0x000001FE (510)	Microsoft ACPI-Compliant System
	(ISA) 0x000001FF (511)	Microsoft ACPI-Compliant System
	(PCI) 0x00000005 (05)	Intel(R) 100 Series/C230 Series Chipset Family SMBus - A123
	(PCI) 0x00000006 (06)	Intel(R) 100 Series/C230 Series Chipset Family Thermal subsystem - A131
	(PCI) 0x00000010 (16)	High Definition Audio Controller
	(PCI) 0xFFFFFFFF (-18)	Intel(R) I211 Gigabit Network Connection #2
	(PCI) 0xFFFFFFFF (-17)	Intel(R) I211 Gigabit Network Connection #2
	(PCI) 0xFFFFFFFF (-16)	Intel(R) I211 Gigabit Network Connection #2
	(PCI) 0xFFFFFFFF (-15)	Intel(R) I211 Gigabit Network Connection
	(PCI) 0xFFFFFFFF (-14)	Intel(R) I211 Gigabit Network Connection
	(PCI) 0xFFFFFFFF (-13)	Intel(R) I211 Gigabit Network Connection
	(PCI) 0xFFFFFFFF (-12)	Intel(R) I211 Gigabit Network Connection
	(PCI) 0xFFFFFFFF (-11)	Intel(R) I211 Gigabit Network Connection
	(PCI) 0xFFFFFFFF (-10)	Intel(R) I211 Gigabit Network Connection
	(PCI) 0xFFFFFFFF (-9)	Intel(R) I211 Gigabit Network Connection #2
	(PCI) 0xFFFFFFFF (-8)	Intel(R) I211 Gigabit Network Connection #2
	(PCI) 0xFFFFFFFF (-7)	Intel(R) I211 Gigabit Network Connection #2
	(PCI) 0xFFFFFFFF (-6)	Intel(R) USB 3.0 eXtensible Host Controller - 1.0 (Microsoft)
	(PCI) 0xFFFFFFFF (-5)	Intel(R) HD Graphics 630
	(PCI) 0xFFFFFFFF (-4)	Standard SATA AHCI Controller
	(PCI) 0xFFFFFFFF (-3)	Intel(R) 100 Series/C230 Series Chipset Family PCI Express Root Port #7 - A116
	(PCI) 0xFFFFFFFF (-2)	Intel(R) 100 Series/C230 Series Chipset Family PCI Express Root Port #6 - A115

>  Memory

# Appendix B

---

Mating Connector Information

## B.1 Mating Connectors

Conn Label	Function	Mating Connector		Available Cable	Cable P/N
		Vendor	Model no		
CN1	LVDS Invertor Connector	JST	PHR-5	NA	NA
CN2	+9~24V Vin Connector	N/A	N/A	Power Cable	1702002010
CN3	LVDS Connector	HIROSE	DF13-30DS-1.25C	N/A	N/A
CN4	External +5VSB Input Connector	JST	PHR-3	ATX Cable	170220020B
CN5	Audio Connector	Molex	51021-1000	Audio Cable	1709100254
CN6	External RTC Connector	Molex	51021-0200	Battery Cable	175011901C
CN7	+5Vout Connector	JST	PHR-2	2 Pins for HDD Power	1702150155
				Dual SATA Power Cable	170X000592
CN8	USB Port Connector	Molex	51021-0500	USB Wafer Cable	1700050207
CN9	USB Port Connector	Molex	51021-0500	USB Wafer Cable	1700050207
CN10	SATA Connector	Molex	88750-5318	SATA Cable	1709070500
CN13	SATA Connector	Molex	88750-5318	SATA Cable	1709070500
CN14	CPU Fan Connector	Molex	22-01-2035	N/A	N/A
CN16	COM Port 2 Connector	Molex	51021-0900	Serial Port Cable	1701090150
CN17	COM Port 1 Connector	Molex	51021-0900	Serial Port Cable	1701090150
CN18	COM Port 3 Connector	Molex	51021-0900	Serial Port Cable	1701090150
CN24	Digital I/O Connector	Neltron	2026B-10	N/A	N/A
CN26	COM Port 4 Connector	Molex	51021-0900	Serial Port Cable	1701090150