

IMBM-Q67A

Industrial Motherboard

Copyright Notice

This document is copyrighted, 2012. All rights are reserved. The original manufacturer reserves the right to make improvements to the products described in this manual at any time without notice.

No part of this manual may be reproduced, copied, translated, or transmitted in any form or by any means without the prior written permission of the original manufacturer. Information provided in this manual is intended to be accurate and reliable. However, the original manufacturer assumes no responsibility for its use, or for any infringements upon the rights of third parties that may result from its use. The material in this document is for product information only and is subject to change without notice. While reasonable efforts have been made in the preparation of this document to assure its accuracy, the original manufacturer assumes no liabilities resulting from errors or omissions in this document, or from the use of the information contained herein.

The original manufacturer reserves the right to make changes in the product design without notice to its users.

Acknowledgments

All other products' name or trademarks are properties of their respective owners.

- AMI is a trademark of American Megatrends Inc.
- Intel®, Core™ are trademarks of Intel® Corporation.
- Microsoft Windows® is a registered trademark of Microsoft Corp.
- ITE is a trademark of Integrated Technology Express, Inc.
- IBM, PC/AT, PS/2, and VGA are trademarks of International Business Machines Corporation.

The original manufacturer reserves the right to make changes in the product design without notice to its users.

All other product names or trademarks are properties of their respective owners.

Contents

Chapter 1: Product overview

1.1	Package contents.....	1-1
1.2	Features	1-1
1.3	Specifications.....	1-2

Chapter 2: Motherboard information

2.1	Before you proceed	2-1
2.2	Motherboard layout.....	2-2
2.3	Screw size.....	2-4
	2.3.1 Component side.....	2-4
	2.3.2 Solder side	2-5
2.4	Central Processing Unit (CPU)	2-6
	2.4.1 Installing the CPU	2-7
	2.4.2 CPU heatsink and fan assembly installation.....	2-9
2.5	System memory	2-11
2.6	Jumpers	2-12
2.7	Connectors	2-14
	2.7.1 Rear panel connectors.....	2-14
	2.7.2 Internal connectors	2-15

Chapter 3: BIOS setup

3.1	BIOS setup program	3-1
3.2	BIOS menu screen	3-2
3.3	Main menu	3-4
	3.3.1 System Date [Day xx/xx/xxxx].....	3-4
	3.3.2 System Time [xx:xx:xx]	3-4
	3.3.3 Security	3-4
3.4	Advanced menu	3-6
	3.4.1 Trusted Computing.....	3-6
	3.4.2 CPU Configuration	3-7
	3.4.3 System Agent Configuration	3-8
	3.4.4 PCH Configuration	3-8
	3.4.5 SATA Configuration.....	3-9
	3.4.6 Intel TXT(LT) Configuration.....	3-10

Contents

- 3.4.7 USB Configuration 3-10
- 3.4.8 ME Subsystem 3-10
- 3.4.9 AMT Configuration 3-11
- 3.4.10 Onboard Devices Configuration 3-11
- 3.4.11 APM 3-13
- 3.4.12 SIO GPIO 3-14
- 3.4.13 Serial Port Console Redirection 3-14
- 3.5 Monitor menu 3-15**
 - 3.5.1 CPU Temperature / MB Temperature [xxx°C/xxx°F] 3-15
 - 3.5.2 CPU / Chassis Fan Speed 3-15
 - 3.5.3 CPU Q-Fan Control [Enabled] 3-16
 - 3.5.4 Chassis Q-Fan Control [Enabled] 3-16
 - 3.5.5 CPU Voltage, 3.3V Voltage, 5V Voltage, 12V Voltage .. 3-17
 - 3.5.6 Anti Surge Support [Enabled] 3-17
- 3.6 Boot menu 3-18**
 - 3.6.1 Bootup NumLock State [On] 3-18
 - 3.6.2 Full Screen Logo [Disabled] 3-18
 - 3.6.3 Post Report [5 sec] 3-18
 - 3.6.4 USB Boot Configuration [Enable All] 3-18
 - 3.6.5 SATA Boot Configuration [Enable All] 3-19
 - 3.6.6 Option ROM Messages [Force BIOS] 3-19
 - 3.6.7 Boot Option Priorities 3-19
 - 3.6.8 Boot Override 3-19
- 3.7 Tools menu 3-20**
 - 3.7.1 EZ Flash 2 Utility 3-20
 - 3.7.2 SPD Information 3-20
 - 3.7.3 O.C. Profile 3-20
- 3.8 Exit menu 3-21**

Appendix

- Notices A-1**

Chapter 1

Product overview

1.1 Package contents

Check your industrial motherboard package for the following items.

- 1 x Industrial Motherboard
- 1 x Cable Kit
- 1 x I/O Shield
- 1 x DVD-ROM for manual (in PDF format) and drivers



NOTE: If any of the above items is damaged or missing, contact your distributor or sales representative immediately.

1.2 Features

- LGA1155 socket For Intel® Second Generation Core™ i7 / Core™ i5 / Core™ i3 Processors
- Four 240-pin Dual Channel DDR3 1333 / 1066MHz DIMM Up To 32GB
- Multi Display: VGA+DisplayPort, VGA+DVI-D, DisplayPort+DVI-D
- Dual Ethernet LAN: Intel® 82579LM, Realtek® 8111F
- SATA 6Gb/s x 3, SATA 3Gb/s x 4, USB2.0 x 14, COM x 2
- PCI-Express[x16] x 1, PCI-Express[x4] x 1, PCI x 2
- Onboard TPM Function
- Onboard Parallel Port Connection
- EuP/ErP Compliance

1.3 Specifications

SYSTEM	
CPU	LGA1155 socket for Intel® Second Generation Core™ i7 / Core™ i5 / Core™ i3 processors
Memory	4 x DIMM (8GB per DIMM), max. 32GB, DDR3 1333 / 1066MHz Dual-channel memory architecture
Chipset	Intel® Q67 Express Chipset
Graphics	Intel® Graphics Media Accelerator
I/O Chipset	NUVOTON NCT6776F
Ethernet	LAN1: Intel® 82579LM LAN2: Realtek® 8111F
Audio	VIA® VT1708S 8-channel high definition audio CODEC Supports Jack-detection, Multi-streaming, and Anti-pop function • Use a chassis with HD audio module in the front panel to support an 8-channel audio output.
TPM	Onboard Infineon SLB9635 TT 1.2
Expansion slot	1 x PCI Express 2.0 x16 slot 1 x PCI Express 2.0 x4 slot 2 x PCI slots
BIOS	64Mb Flash ROM, UEFI AMI BIOS, PnP, DMI 2.0, SM BIOS, ACPI 3.0b
H/W Status Monitor	Monitors CPU/system temperature Monitors Vcore, 3.3V/5V/12V voltages Monitors CPU/chassis fan speed
Watchdog Timer	1~255 steps by software program
Smart Fan Control	CPU fan / Chassis fan
Wake On LAN / PXE	LAN1: Supports Intel® AMT 7.0 LAN2: Supports WOL, PXE
Power States	S3, S4, S5
Environment, Power, and ME	
Battery	Lithium battery
Power requirement	1 x 24-pin ATX connector 1 x 8-pin EATX 12V power connector
Power compliance	Compliant with Eup/ErP
Operating temperature	32°F~140°F (0°C~60°C)
Operating humidity	0%~80% relative humidity, non-condensing
Form factor	Micro ATX form factor: 9.6 in. x 9.6 in. (24.4 cm x 24.4 cm)
Gross weight	1.55 lb (0.7 Kg)
EMI	CE, FCC

(continued on the next page)

DISPLAY	
Chipset	Intel® Graphics Media Accelerator
Multi display	VGA+DisplayPort, VGA+DVI-D, DisplayPort+DVI-D
Resolution	Up to 2048x1536@75Hz for VGA Up to 1920x1200@60Hz for DVI-D Up to 2560x1600@60Hz for DisplayPort
I/O	
Storage	3 x SATA 6Gb/s ports 4 x SATA 3Gb/s ports
USB	10 x USB2.0 (Pin header, at mid-board) 4 x USB2.0 (Type A port) on rear I/O
Display I/O	1 x VGA port, 1 x DVI-D port, 1 x DisplayPort
Audio I/O	Line-in, Mic-in, Line-out, AAFP, S/PDIF
LAN I/O	2 x RJ-45 ports on rear I/O
Serial port	1 x RS-232/422/485 box header (COM1) 1 x RS-232 box header (COM2)
Parallel port	SPP/EPP/ECP mode
PS/2 port	1 x PS/2 Keyboard on rear I/O 1 x PS/2 Mouse on rear I/O
DIO	8-bit Digital I/O interface (4-in/4-out)
Fan	1 x CPU fan connector, 1 x Chassis fan connector
RTC	Internal RTC
I/O Placement	
Internal I/O connectors	1 x PCIe 2.0 x16 slot 1 x PCIe 2.0 x4 slot 2 x PCI slots 1 x Front panel audio connector (AAFP) 1 x S/PDIF out header 3 x SATA 6Gb/s connector 4 x SATA 3Gb/s connector 1 x CPU fan connector (4-pin) 1 x Chassis fan connector (3-pin) 1 x 24-pin ATX power connector 1 x 8-pin EATX 12V power connector 1 x System panel connector 1 x LPT connector 1 x DIO connector 1 x RS-232/422/485 box header 1 x RS-232 box header 5 x USB 2.0 pin headers (support 10 USB 2.0 ports)

(continued on the next page)

I/O Placement	
Back panel I/O ports	1 x VGA port 1 x DVI-D port 1 x DP port 2 x LAN (RJ-45) port 4 x USB 2.0 ports 1 x PS/2 keyboard port 1 x PS/2 mouse port 3 x Audio jacks
Others	
Supported OS	Windows® XP 32-bit, Windows® 7 32/64-bit, Linux Fedora
Accessories	2 x Serial ATA 3Gb/s cables 1 x Serial cable 1 x I/O Shield 1 x Support DVD (Drivers, Manual)



NOTE: Specifications are subject to change without notice.

Chapter 2

Motherboard information

2.1 Before you proceed

Take note of the following precautions before you install motherboard components or change any motherboard settings.



CAUTION!

- Unplug the power cord from the wall socket before touching any component.
- Before handling components, use a grounded wrist strap or touch a safely grounded object or a metal object, such as the power supply case, to avoid damaging them due to static electricity.
- Hold components by the edges to avoid touching the ICs on them.
- Whenever you uninstall any component, place it on a grounded antistatic pad or in the bag that came with the component.
- Before you install or remove any component, ensure that the ATX power supply is switched off or the power cord is detached from the power supply. Failure to do so may cause severe damage to the motherboard, peripherals, or components.

Standby Power LED

The motherboard comes with a standby power LED that lights up to indicate that the system is ON, in sleep mode, or in soft-off mode. This is a reminder that you should shut down the system and unplug the power cable before removing or plugging in any motherboard component. The illustration below shows the location of the onboard LED.

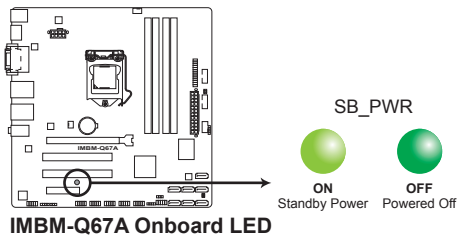

2.2 Motherboard layout



NOTE: Place eight screws into the holes indicated by circles to secure the motherboard to the chassis.



CAUTION! Do not overtighten the screws! Doing so can damage the motherboard.

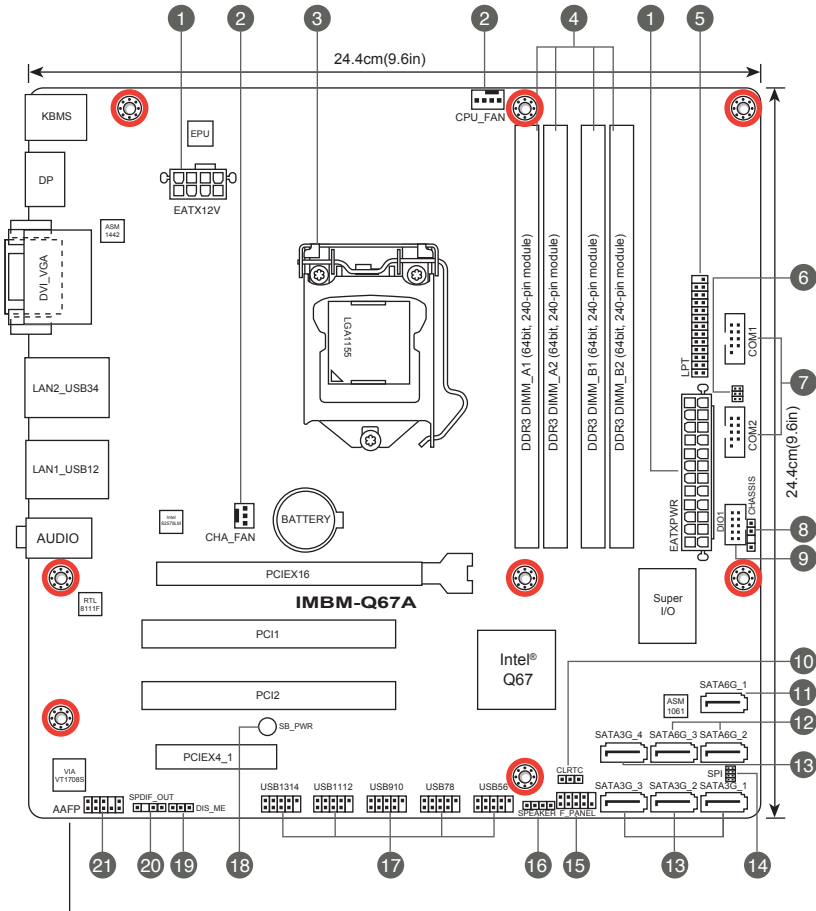

Place this side towards the rear of the chassis

Connectors/Jumpers/Slots		Page
1.	ATX power connectors (24-pin EATXPWR, 8-pin EATX12V)	2-16
2.	CPU and chassis fan connectors (4-pin CPU_FAN, 3-pin CHA_FAN)	2-17
3.	Intel® LGA1155 CPU socket	2-6
4.	DDR3 DIMM slots	2-11
5.	LPT connector (26-1 pin LPT)	2-17
6.	COM1 Ring and voltage selection (6-pin)	2-13
7.	Serial port connectors (10-1 pin COM1/2)	2-23
8.	Chassis intrusion connector (4-1 pin CHASSIS)	2-19
9.	Digital I/O connector (10-pin DIO1)	2-23
10.	Clear RTC RAM (3-pin CLRTC)	2-12
11.	ASM 1061 Serial ATA 6Gb/s connector (7-pin SATA6G_1)	2-21
12.	Intel® Q67 Serial ATA 6Gb/s connectors (7-pin SATA6G_2/3)	2-20
13.	Intel® Q67 Serial ATA 3Gb/s connectors (7-pin SATA3G_1~4)	2-19
14.	SPI programming connector (8-pin SPI)	2-16
15.	System panel connector (10-1 pin F_PANEL)	2-18
16.	Speaker connector (4-pin SPEAKER)	2-18
17.	USB 2.0 connectors (10-pin USB5~14)	2-22
18.	Standby Power LED (SB_PWR)	2-1
19.	Intel® ME jumper (3-pin DIS_ME)	2-13
20.	Digital audio connector (4-1 pin SPDIF_OUT)	2-20
21.	Front panel audio connector (10-1 pin AAFP)	2-15

2.3 Screw size

2.3.1 Component side

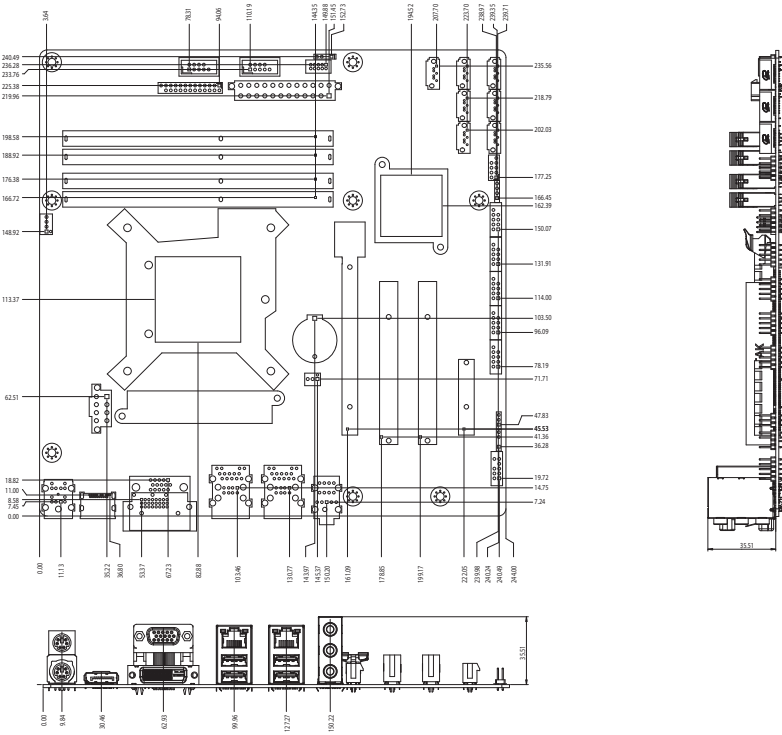

2.3.2 Solder side

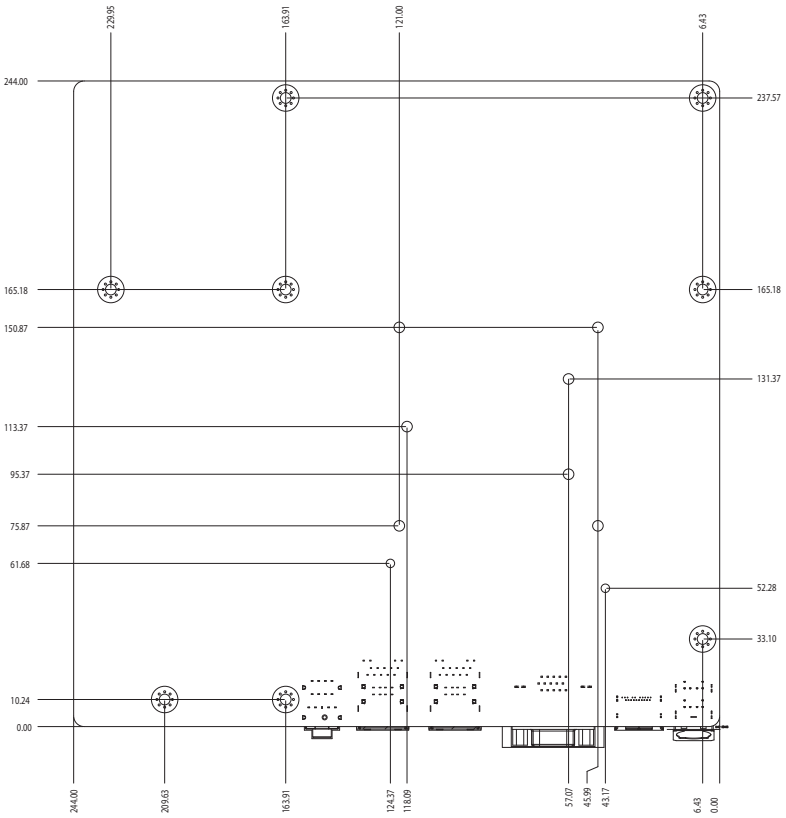

2.4 Central Processing Unit (CPU)

The motherboard comes with a surface mount LGA1155 socket designed for the Intel® Second Generation Core™ i7 / Core™ i5 / Core™ i3 processors.

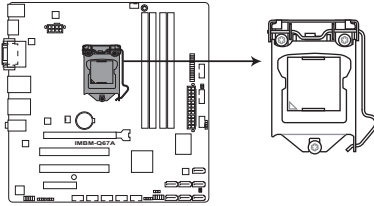

IBM-Q67A CPU socket LGA1155



IMPORTANT: Unplug all power cables before installing the CPU.



CAUTION!

- Upon purchase of the motherboard, ensure that the PnP cap is on the socket and the socket contacts are not bent. Contact your retailer immediately if the PnP cap is missing, or if you see any damage to the PnP cap/socket contacts/motherboard components. The manufacturer will shoulder the cost of repair only if the damage is shipment/transit-related.
 - Keep the cap after installing the motherboard. The manufacturer will process Return Merchandise Authorization (RMA) requests only if the motherboard comes with the cap on the LGA1155 socket.
 - The product warranty does not cover damage to the socket contacts resulting from incorrect CPU installation/removal, or misplacement/loss/incorrect removal of the PnP cap.
-

2.4.1 Installing the CPU



CAUTION! The LGA1156 CPU is incompatible with the LGA1155 socket. DO NOT install a LGA1156 CPU on the LGA1155 socket.

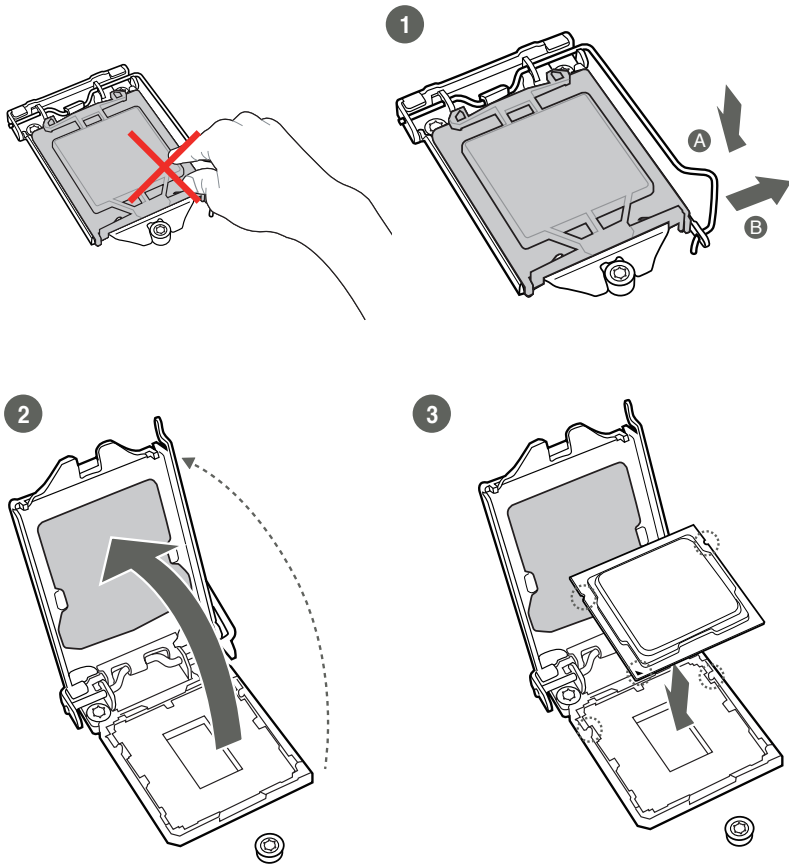

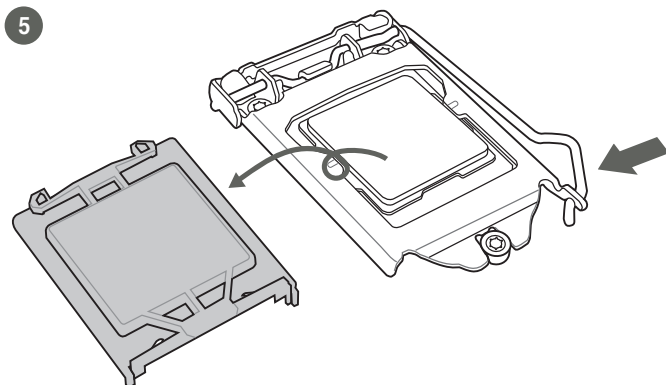
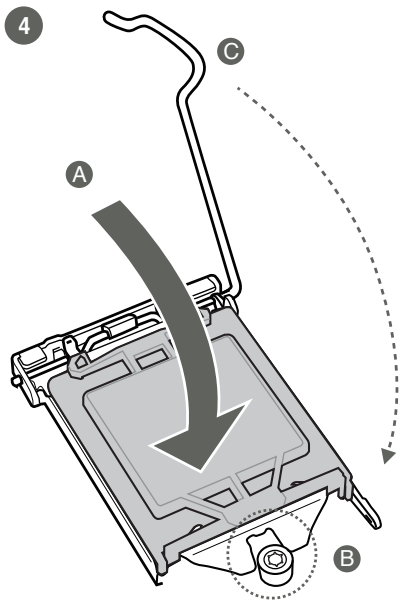

2.4.2 CPU heatsink and fan assembly installation

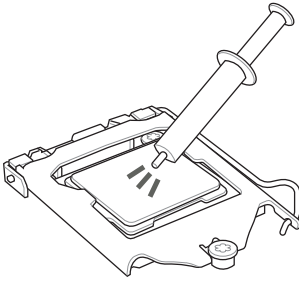

CAUTION! Apply the Thermal Interface Material to the CPU heatsink and CPU before you install the heatsink and fan if necessary.

To install the CPU heatsink and fan assembly

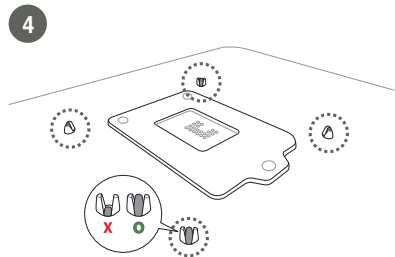
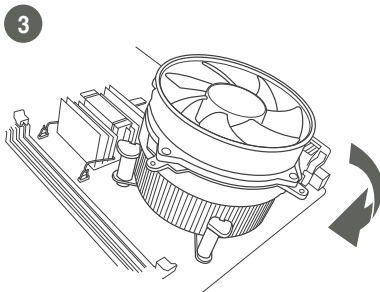
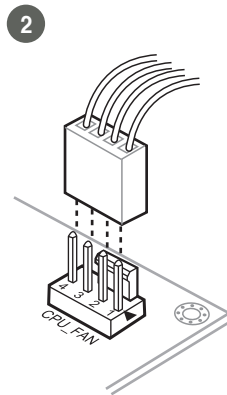
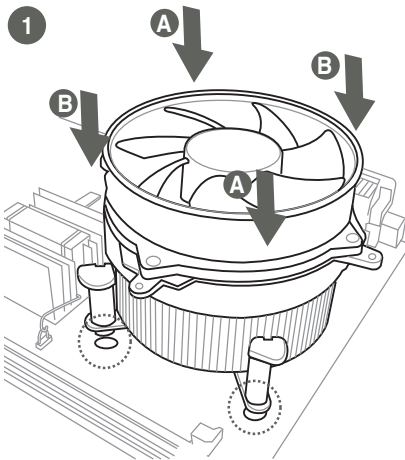

To uninstall the CPU heatsink and fan assembly

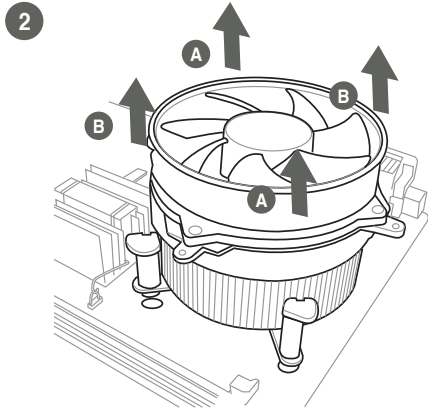
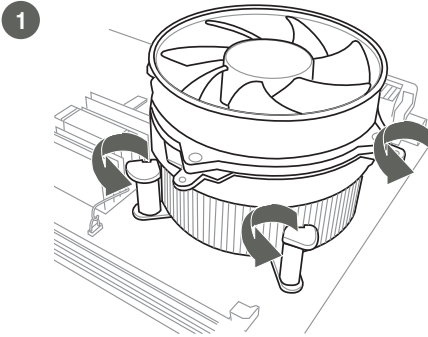

2.5 System memory

Installing a DIMM

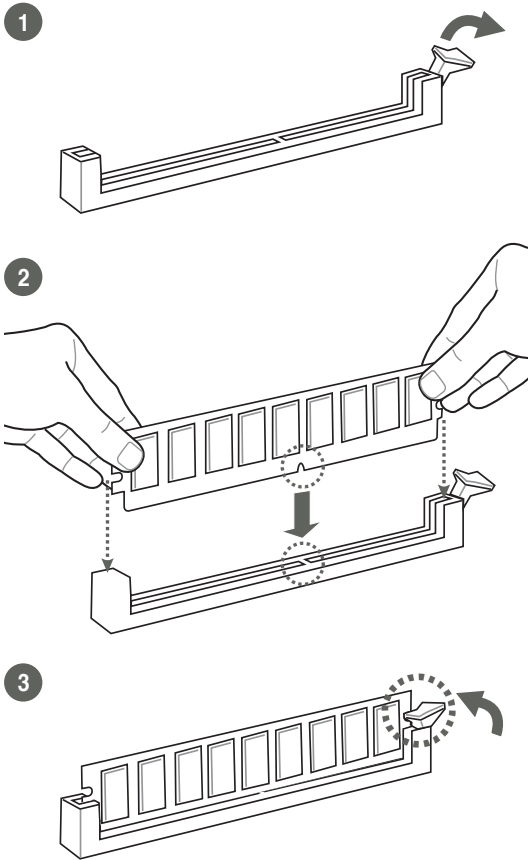

To remove a DIMM

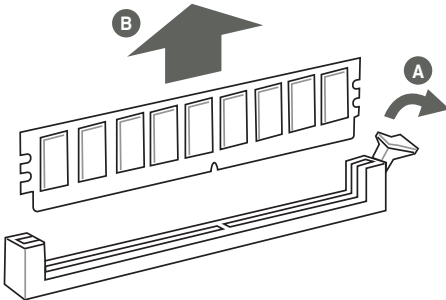

2.6 Jumpers

1. Clear RTC RAM (CLRRTC)

This jumper allows you to clear the Real Time Clock (RTC) RAM in CMOS. You can clear the CMOS memory of date, time, and system setup parameters by erasing the CMOS RTC RAM data. The onboard button cell battery powers the RAM data in CMOS, which include system setup information such as system passwords.

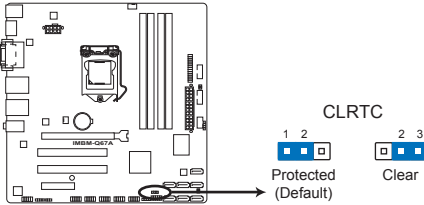

IMBM-Q67A Clear RTC RAM

To erase the RTC RAM:

1. Turn OFF the computer and unplug the power cord.
2. Move the jumper cap from pins 1-2 (default) to pins 2-3. Keep the cap on pins 2-3 for about 5~10 seconds, then move the cap back to pins 1-2.
3. Plug the power cord and turn ON the computer.
4. Hold down the **** key during the boot process and enter BIOS setup to reenter data.



CAUTION! Except when clearing the RTC RAM, never remove the cap on CLRRTC jumper default position. Removing the cap will cause system boot failure!



NOTES:

- If the steps above do not help, remove the onboard battery and move the jumper again to clear the CMOS RTC RAM data. After clearing the CMOS, reinstall the battery.
 - You do not need to clear the RTC when the system hangs due to overclocking. For system failure due to overclocking, use the CPU Parameter Recall (C.P.R) feature. Shut down and reboot the system so the BIOS can automatically reset parameter settings to default values.
-

2. Intel® ME jumper (3-pin DIS_ME)

This jumper allows you to enable or disable the Intel® ME function. Set this jumper to pins 1-2 to enable (default) the Intel® ME function and to pins 2-3 to disable it.

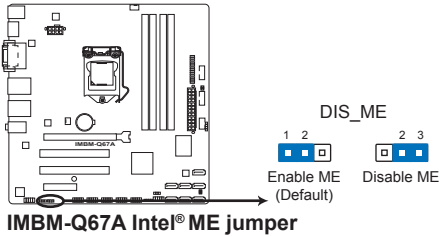

Disable the Intel® ME function before updating it.

3. COM1 Ring and voltage selection (6-pin)

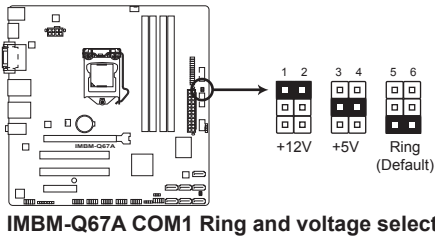

Pins	
1-2	+12V
3-4	+5V
5-6	Ring (Default)

2.7 Connectors

2.7.1 Rear panel connectors

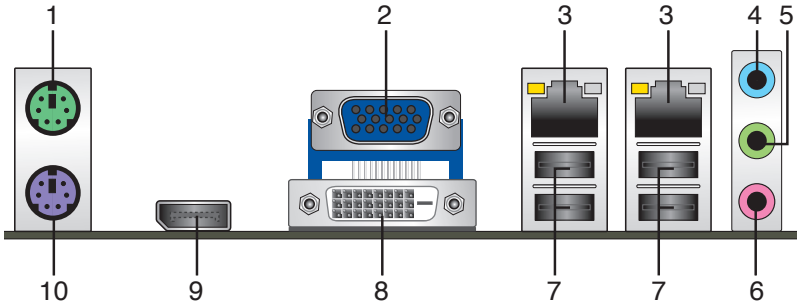

1. **PS/2 Mouse port (green).** This port is for a PS/2 mouse.
2. **Video Graphics Adapter (VGA) port.** This 15-pin port is for a VGA monitor or other VGA-compatible devices.
3. **LAN (RJ-45) ports.** These ports allow Gigabit connection to a Local Area Network (LAN) through a network hub. Refer to the table below for the LAN port LED indications.

LAN port LED indications

ACT/LINK LED		SPEED LED	
Status	Description	Status	Description
OFF	No link	OFF	10 Mbps connection
ORANGE	Linked	ORANGE	100 Mbps connection
BLINKING	Data activity	GREEN	1 Gbps connection

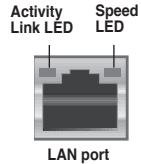

4. **Line In port (light blue).** This port connects to the tape, CD, DVD player, or other audio sources.
5. **Line Out port (lime).** This port connects to a headphone or a speaker. In the 4, 6, and 8-channel configurations, the function of this port becomes Front Speaker Out.
6. **Microphone port (pink).** This port connects to a microphone.



NOTE: To configure an 8-channel audio output:

Use a chassis with HD audio module in the front panel to support an 8-channel audio output.



NOTE: Refer to the audio configuration table on the next page for the function of the audio ports in the 2, 4, 6, or 8-channel configuration.

Audio 2, 4, 6, 8-channel configuration

Port	2-channel	4-channel	6-channel	8-channel
Light Blue (Rear panel)	Line In	Rear Speaker Out	Rear Speaker Out	Rear Speaker Out
Lime (Rear panel)	Line Out	Front Speaker Out	Front Speaker Out	Front Speaker Out
Pink (Rear panel)	Mic In	Mic In	Bass/Center	Bass/Center
Lime (Front panel)	-	-	-	Side Speaker Out

- USB 2.0 ports.** These two 4-pin Universal Serial Bus (USB) ports are available for connecting USB 2.0/1.1 devices.
- DVI-D port.** This port is for any DVI-D compatible device. DVI-D can't be converted to output RGB Signal to CRT and isn't compatible with DVI-I.
- DisplayPort.** This port connects a display monitor or a home-theater system.
- PS/2 Keyboard port (purple).** This port is for a PS/2 keyboard.

2.7.2 Internal connectors

1. Front panel audio connector (10-1 pin AAFP)

This connector is for a chassis-mounted front panel audio I/O module that supports either HD Audio or legacy AC'97 audio standard. Connect one end of the front panel audio I/O module cable to this connector.

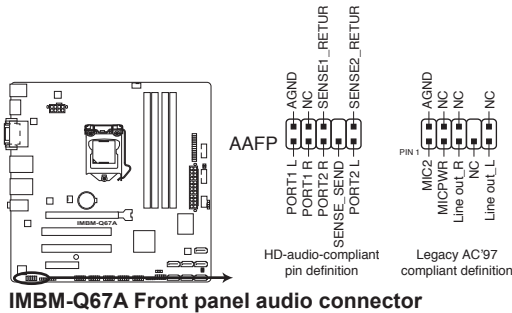

- We recommend that you connect a high-definition front panel audio module to this connector to avail of the motherboard's high-definition audio capability.
- If you want to connect a high-definition front panel audio module to this connector, set the **Front Panel Type** item in the BIOS setup to **[HD]**. If you want to connect an AC'97 front panel audio module to this connector, set the item to **[AC97]**. By default, this connector is set to **[HD]**. See section 3.4.10 **Onboard Devices Configuration** for details.

2. ATX power connectors (24-pin EATXPWR, 8-pin EATX12V)

These connectors are for ATX power supply plugs. The power supply plugs are designed to fit these connectors in only one orientation. Find the proper orientation and push down firmly until the connectors completely fit.

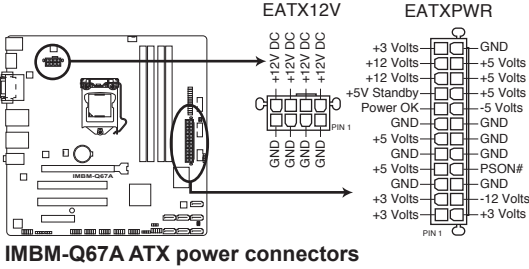

IMPORTANT:

- For a fully configured system, we recommend that you use a power supply unit (PSU) that complies with ATX 12 V Specification 2.0 (or later version) and provides a minimum power of 350 W.
- DO NOT forget to connect the 4-pin / 8-pin ATX +12V power plug. Otherwise, the system will not boot up.
- We recommend that you use a PSU with higher power output when configuring a system with more power-consuming devices. The system may become unstable or may not boot up if the power is inadequate.

3. SPI programming connector (8-pin SPI)

Use this connector to flash BIOS SPI ROM.

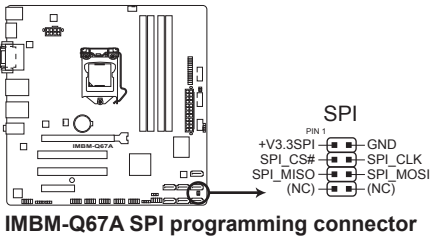

4. CPU and chassis fan connectors (4-pin CPU_FAN, 3-pin CHA_FAN)

Connect the fan cables to the fan connectors on the motherboard, ensuring that the black wire of each cable matches the ground pin of the connector.

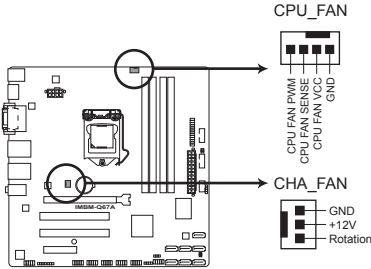

IBM-Q67A Fan connectors



CAUTION: Do not forget to connect the fan cables to the fan connectors. Insufficient air flow inside the system may damage the motherboard components. These are not jumpers! Do not place jumper caps on the fan connectors!



NOTES:

- The CPU_FAN connector supports a CPU fan of maximum 2A (24 W) fan power.
- Only the 4-pin CPU fan support the Q-Fan feature.

5. LPT connector (26-1 pin LPT)

The LPT (Line Printing Terminal) connector supports devices such as a printer. LPT is standardized as IEEE 1284, which is the parallel port interface on IBM PC-compatible computers.

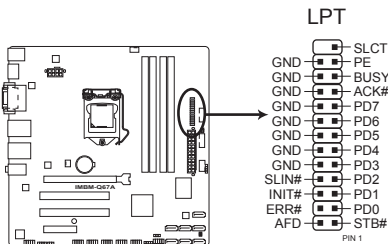

IBM-Q67A Parallel port connector

6. System panel connector (10-1 pin F_PANEL)

This connector supports several chassis-mounted functions.

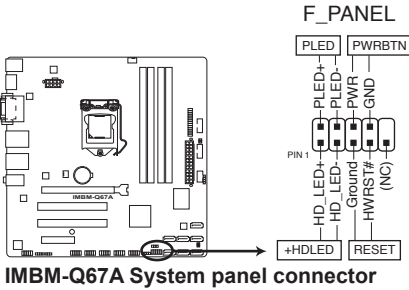

- **System power LED (2-pin PLED)**

This 2-pin connector is for the system power LED. Connect the chassis power LED cable to this connector. The system power LED lights up when you turn on the system power, and blinks when the system is in sleep mode.

- **Hard disk drive activity LED (2-pin +HDLED)**

This 2-pin connector is for the HDD Activity LED. Connect the HDD Activity LED cable to this connector. The IDE LED lights up or flashes when data is read from or written to the HDD.

- **ATX power button/soft-off button (2-pin PWRBTN)**

This 2-pin connector is for the system power button.

- **Reset button (2-pin RESET)**

This 2-pin connector is for the chassis-mounted reset button for system reboot without turning off the system power.

7. Speaker connector (4-pin SPEAKER)

The 4-pin connector is for the chassis-mounted system warning speaker. The speaker allows you to hear system beeps and warnings.

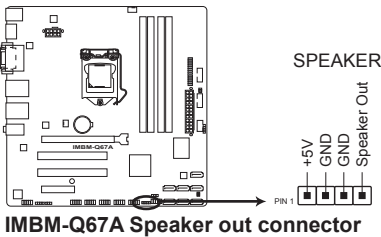

8. Intel® Q67 Serial ATA 3Gb/s connectors (7-pin SATA3G_1~4 [blue])

These connectors connect to Serial ATA 3Gb/s hard disk drives and optical drives via Serial ATA 3Gb/s signal cables.

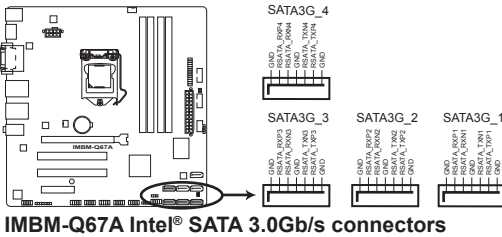

IMBM-Q67A Intel® SATA 3.0Gb/s connectors



NOTES:

- These connectors are set to [IDE Mode] by default. In IDE mode, you can connect Serial ATA boot/data hard disk drives to these connectors. If you intend to create a Serial ATA RAID set using these connectors, set the **SATA Mode** item in the BIOS to [RAID Mode]. See section **3.4.5 SATA Configuration** for details.
- You must install Windows® XP Service Pack 3 or later version before using Serial ATA hard disk drives. The Serial ATA RAID feature (RAID 0, 1, 5, and 10) is available only if you are using Windows® XP SP3 or later version.
- When using hot-plug and NCQ, set the **SATA Mode** item in the BIOS to [AHCI Mode]. See section **3.4.5 SATA Configuration** for details.

9. Chassis intrusion connector (4-1 pin CHASSIS)

This connector is for a chassis-mounted intrusion detection sensor or switch. Connect one end of the chassis intrusion sensor or switch cable to this connector. The chassis intrusion sensor or switch sends a high-level signal to this connector when a chassis component is removed or replaced. The signal is then generated as a chassis intrusion event.

By default, the pin labeled “Chassis Signal” and “Ground” are shorted with a jumper cap. Remove the jumper caps only when you intend to use the chassis intrusion detection feature.

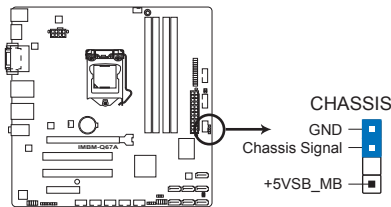

IMBM-Q67A Chassis intrusion connector

10. Intel® Q67 Serial ATA 6Gb/s connectors (7-pin SATA6G_2/3 [gray])

These connectors connect to Serial ATA 6Gb/s hard disk drives and optical drives via Serial ATA 6Gb/s signal cables.

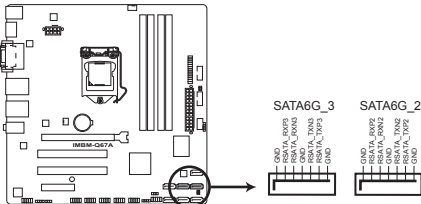

IMBM-Q67A Intel® SATA 6.0Gb/s connectors



NOTES:

- These connectors are set to [IDE Mode] by default. In IDE mode, you can connect Serial ATA boot/data hard disk drives to these connectors. If you intend to create a Serial ATA RAID set using these connectors, set the **SATA Mode** item in the BIOS to [RAID Mode]. See section 3.4.5 **SATA Configuration** for details.
- You must install Windows® XP Service Pack 3 or later version before using Serial ATA hard disk drives. The Serial ATA RAID feature (RAID 0, 1, 5, and 10) is available only if you are using Windows® XP SP3 or later version.
- When using hot-plug and NCQ, set the **SATA Mode** item in the BIOS to [AHCI Mode]. See section 3.4.5 **SATA Configuration** for details.

11. Digital audio connector (4-1 pin SPDIF_OUT)

This connector is for an additional Sony/Philips Digital Interface (S/PDIF) port. Connect the S/PDIF Out module cable to this connector, then install the module to a slot opening at the back of the system chassis.

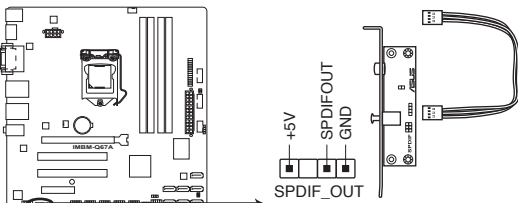

IMBM-Q67A Digital audio connector



The S/PDIF module is purchased separately.

12. ASM 1061 Serial ATA 6Gb/s connector (7-pin SATA6G_1 [gray])

This connector connects to Serial ATA 6Gb/s hard disk drives and optical drives via Serial ATA 6Gb/s signal cables.

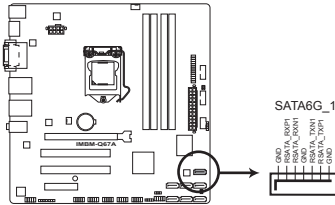

IBM-Q67A ASM 1061 SATA 6.0Gb/s connector



NOTES:

- This connector is set to [IDE Mode] by default. In IDE mode, you can connect Serial ATA bootable hard disk drives installed only with Windows® XP / Windows® 7, or Serial ATA data hard disk drives to this connector.
 - ATAPI devices are not supported on this connector.
 - You must install Windows® XP Service Pack 3 or later version before using Serial ATA hard disk drives.
 - When using hot-plug and NCQ, set the **ASM1061 Storage Controller** item in the BIOS to [AHCI Mode]. See section **3.4.10 Onboard Devices Configuration** for details.
-

13. USB 2.0 connectors (10-1 pin USB5~14)

These connectors are for USB 2.0 ports. Connect the USB module cable to any of these connectors, then install the module to a slot opening at the back of the system chassis. These USB connectors comply with USB 2.0 specification that supports up to 480 Mbps connection speed.

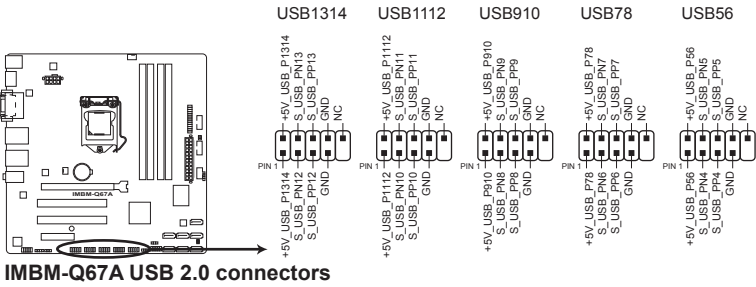
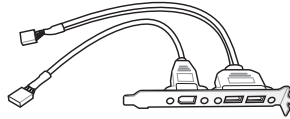

CAUTION! Never connect a 1394 cable to the USB connectors. Doing so will damage the motherboard!



NOTE: The USB module cable is purchased separately.

14. Serial port connectors (10-1 pin COM1/2)

These connectors are for serial (COM) ports. Connect the serial port module cable to this connector, then install the module to a slot opening at the back of the system chassis.

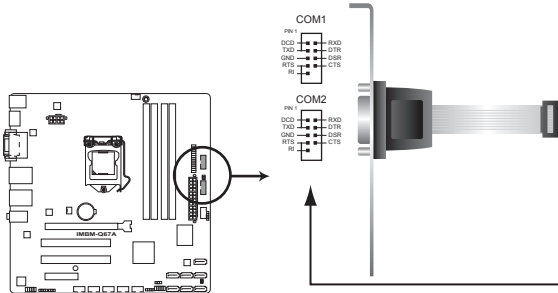

IMBM-Q67A Serial port connectors



NOTE: The COM module is purchased separately.

15. Digital I/O connector (10-pin DIO1)

This connector includes 8 I/O lines. All of the Digital I/O lines are programmable and each I/O pin can be individually programmed to support various devices.

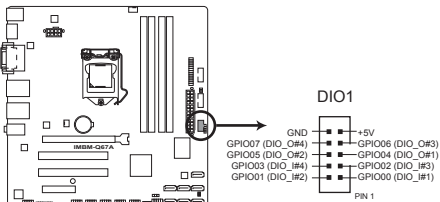

IMBM-Q67A DIO connector



NOTE: To configure the I/O pins in BIOS, click **Advanced** tab > **SIO GPIO** > **GPIO 1~8**. See section 3.4.12 **SIO GPIO** for details.

Chapter 3

BIOS setup

3.1 BIOS setup program

Use the BIOS Setup program to update the BIOS or configure its parameters. The BIOS screens include navigation keys and brief online help to guide you in using the BIOS Setup program.

Entering BIOS Setup at startup

To enter BIOS Setup at startup:

- Press <Delete> during the Power-On Self Test (POST). If you do not press <Delete>, POST continues with its routines.

Entering BIOS Setup after POST

To enter BIOS Setup after POST:

- Press <Ctrl>+<Alt>+ simultaneously.
- Press the reset button on the system chassis.
- Press the power button to turn the system off then back on. Do this option only if you failed to enter BIOS Setup using the first two options.



NOTE: Using the power button, reset button, or the <Ctrl>+<Alt>+ keys to force reset from a running operating system can cause damage to your data or system. We recommend to always shut down the system properly from the operating system.



IMPORTANT:

- The default BIOS settings for this motherboard apply for most conditions to ensure optimum performance. If the system becomes unstable after changing any BIOS settings, load the default settings to ensure system compatibility and stability. Select any of the load default settings under the Save & Exit Menu. See section **3.8 Save & Exit Menu**.
 - Ensure that a USB mouse is connected to your motherboard if you want to use the mouse to control the BIOS setup program.
 - The BIOS setup screens shown in this section are for reference purposes only, and may not exactly match what you see on your screen.
-

3.2 BIOS menu screen

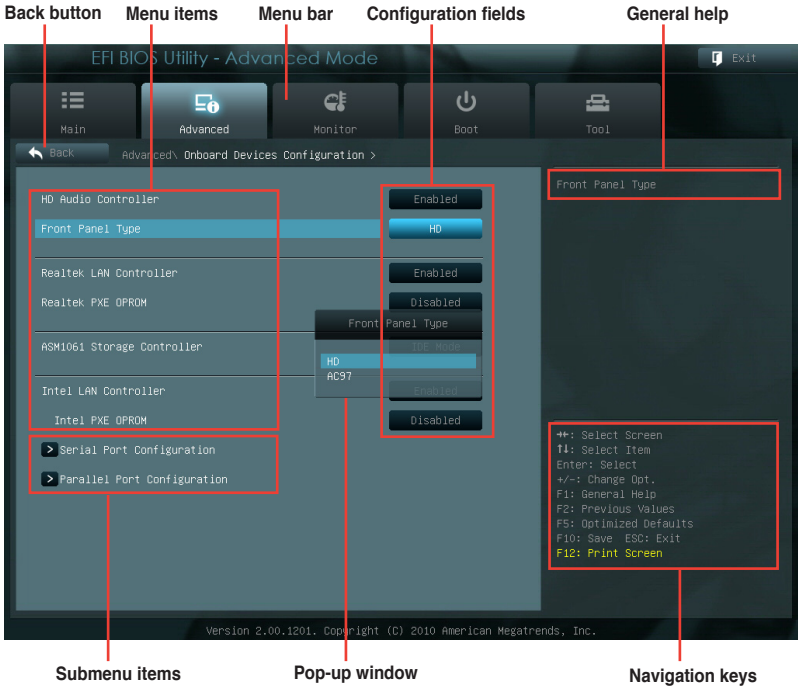

Menu bar

The menu bar on top of the screen has the following main items:

- Main** For changing the basic system configuration.
- Advanced** For changing the advanced system settings.
- Monitor** For displaying the system temperature, power status, and changing the fan settings
- Boot** For changing the system boot configuration.
- Tool** For configuring options for special functions.
- Exit** For selecting the exit options and loading default settings.

Menu items

The highlighted item on the menu bar displays the specific items for that menu. For example, selecting **Main** shows the Main menu items.

The other items (Ai Tweaker, Advanced, Monitor, Boot, Tool, and Exit) on the menu bar have their respective menu items.

Back button

This button appears when entering a submenu. Press <Esc> or use the USB mouse to click this button to return to the previous menu screen.

Submenu items

A greater than sign (>) before each item on any menu screen means that the item has a submenu. To display the submenu, select the item and press <Enter>.

Pop-up window

Select a menu item and press <Enter> to display a pop-up window with the configuration options for that item.

Navigation keys

At the bottom right corner of the menu screen are the navigation keys for the BIOS setup program. Use the navigation keys to select items in the menu and change the settings.

General help

At the top right corner of the menu screen is a brief description of the selected item.

Configuration fields

These fields show the values for the menu items. If an item is user-configurable, you can change the value of the field opposite the item. You cannot select an item that is not user-configurable.

A configurable field is highlighted when selected. To change the value of a field, select it and press <Enter> to display a list of options.

3.3 Main menu

The Main menu screen appears when you enter the Advanced Mode of the BIOS Setup program. The Main menu provides you an overview of the basic system information, and allows you to set the system date, time, language, and security settings.

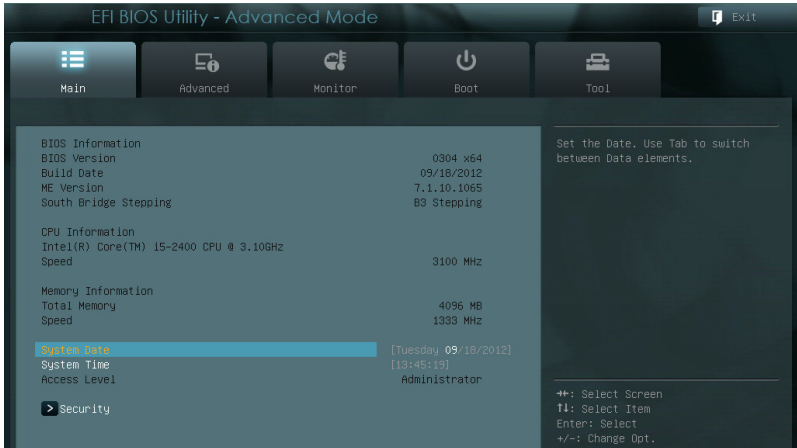

3.3.1 System Date [Day xx/xx/xxxx]

Allows you to set the system date.

3.3.2 System Time [xx:xx:xx]

Allows you to set the system time.

3.3.3 Security

The Security menu items allow you to change the system security settings.



NOTES:

- If you have forgotten your BIOS password, erase the CMOS Real Time Clock (RTC) RAM to clear the BIOS password. See section **2.6 Jumpers** for information on how to erase the RTC RAM.
- The **Administrator** or **User Password** items on top of the screen show the default **Not Installed**. After you set a password, these items show **Installed**.

Administrator Password

If you have set an administrator password, we recommend that you enter the administrator password for accessing the system. Otherwise, you might be able to see or change only selected fields in the BIOS setup program.

To set an administrator password:

1. Select the **Administrator Password** item and press <Enter>.
2. From the **Create New Password** box, key in a password, then press <Enter>.
3. Confirm the password when prompted.

To change an administrator password:

1. Select the **Administrator Password** item and press <Enter>.
2. From the **Enter Current Password** box, key in the current password, then press <Enter>.
3. From the **Create New Password** box, key in a new password, then press <Enter>.
4. Confirm the password when prompted.

To clear the administrator password, follow the same steps as in changing an administrator password, but press <Enter> when prompted to create/confirm the password. After you clear the password, the **Administrator Password** item on top of the screen shows **Not Installed**.

User Password

If you have set a user password, you must enter the user password for accessing the system. The **User Password** item on top of the screen shows the default **Not Installed**. After you set a password, this item shows **Installed**.

To set a user password:

1. Select the **User Password** item and press <Enter>.
2. From the **Create New Password** box, key in a password, then press <Enter>.
3. Confirm the password when prompted.

To change a user password:

1. Select the **User Password** item and press <Enter>.
2. From the **Enter Current Password** box, key in the current password, then press <Enter>.
3. From the **Create New Password** box, key in a new password, then press <Enter>.
4. Confirm the password when prompted.

To clear the user password, follow the same steps as in changing a user password, but press <Enter> when prompted to create/confirm the password. After you clear the password, the **User Password** item on top of the screen shows **Not Installed**.

3.4 Advanced menu

The Advanced menu items allow you to change the settings for the CPU and other system devices.



CAUTION: Be cautious when changing the settings of the Advanced menu items. Incorrect field values can cause the system to malfunction.

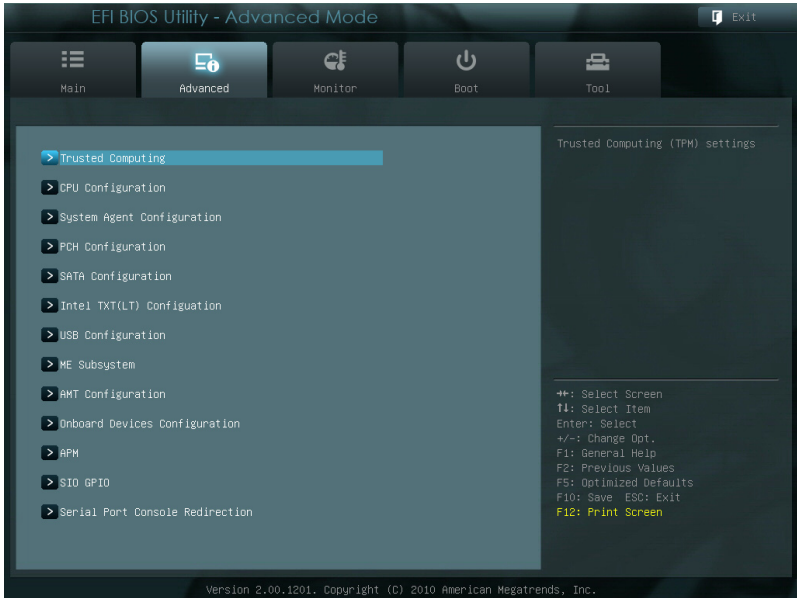

3.4.1 Trusted Computing

The items in this menu allow you to set the TPM (Trusted Platform Module) feature.



NOTE: The following items function only when a TPM module is installed in this motherboard.

TPM Support [Enabled]

Allows you to enable or disable the TPM support. Configuration options: [Disabled] [Enabled]

TPM State [Disabled]

This item appears only when you set the **TPM Support** item to [Enabled] and allows you to enable or disable the TPM after POST. Reboot your system for the changes to take effect. Configuration options: [Disabled] [Enabled]

3.4.2 CPU Configuration

The items in this menu show the CPU-related information that the BIOS automatically detects.



IMPORTANT: The items shown in submenu may be different due to the CPU you installed.

CPU Ratio [Auto]

Allows you to set the ratio between the CPU Core Clock and the BCLK Frequency. Use <+> and <-> keys or the numeric keypad to adjust the ratio. The valid value ranges vary according to your CPU model.

Intel Adaptive Thermal Monitor [Enabled]

[Enabled] Enables the overheated CPU to throttle its clock speed to cool down.

[Disabled] Disables the CPU thermal monitor function.

Active Processor Cores [All]

Allows you to choose the number of CPU cores to activate in each processor package. Configuration options: [All] [1] [2] [3]

Limit CPUID Maximum [Disabled]

[Enabled] Allows legacy operating systems to boot even without support for CPUs with extended CPUID functions.

[Disabled] Disables this function.

Execute Disable Bit [Enabled]

[Enabled] Enables the No-Execution Page Protection Technology.

[Disabled] Forces the XD feature flag to always return to zero (0).

Intel Virtualization Technology [Disabled]

[Enabled] Allows a hardware platform to run multiple operating systems separately and simultaneously, enabling one system to virtually function as several systems.

[Disabled] Disables this function.

Enhanced Intel SpeedStep Technology [Enabled]

Allows you to enable or disable the Enhanced Intel® SpeedStep Technology (EIST).

[Disabled] The CPU runs at its default speed.

[Enabled] The operating system controls the CPU speed.

Turbo Mode [Enabled]

Allows you to enable or disable the Intel® Turbo Mode Technology.

[Enabled] Allows processor cores to run faster than marked frequency in specific condition.

[Disabled] Disables this function.

CPU C1E [Auto]

Enables or disables the C1E support function. This item should be enabled in order to enable the Enhanced Halt State. Configuration options: [Auto] [Enabled] [Disabled]

CPU C3 Report [Auto]

Allows you to disable or enable the CPU C3 report to the operating system. Configuration options: [Auto] [Enabled] [Disabled]

CPU C6 Report [Auto]

Allows you to disable or enable the CPU C6 report to the operating system. Configuration options: [Auto] [Enabled] [Disabled]

3.4.3 System Agent Configuration

VT-d [Disabled]

[Disabled] Disables the Intel Virtualization Technology for Directed I/O.

[Enabled] Enables the Intel Virtualization Technology for Directed I/O.

Initiate Graphic Adapter [PEG/PCI]

Allows you to decide which graphics controller to use as the primary boot device. Configuration options: [iGPU] [PCI/iGPU] [PCI/PEG] [PEG/iGPU] [PEG/PCI]

iGPU Memory [64M]

Allows you to set the iGPU memory size. Configuration options: [32M] [64M] [96M] [128M] ~ [448M] [480M] [512M]

iGPU Multi-Monitor [Disabled]

Allows you to enable or disable the internal graphics device's multi-monitor support for add-on VGA devices. And the memory size for internal graphics device will keep at 64MB. Configuration options: [Disabled] [Enabled]

3.4.4 PCH Configuration

High Precision Timer [Enabled]

Allows you to enable or disable the High Precision Event Timer. Configuration options: [Enabled] [Disabled]

3.4.5 SATA Configuration

While entering Setup, the BIOS automatically detects the presence of SATA devices. The SATA Port items show **Not Present** if no SATA device is installed to the corresponding SATA port.

SATA Mode [IDE Mode]

Allows you to set the SATA configuration.

- [Disabled] Disables the SATA controller.
- [IDE Mode] Set to [IDE Mode] when you want to use the Serial ATA hard disk drives as Parallel ATA physical storage devices.
- [AHCI Mode] Set to [AHCI Mode] when you want the SATA hard disk drives to use the AHCI (Advanced Host Controller Interface). The AHCI allows the onboard storage driver to enable advanced Serial ATA features that increases storage performance on random workloads by allowing the drive to internally optimize the order of commands.
- [RAID Mode] Set to [RAID Mode] when you want to create a RAID configuration from the SATA hard disk drives.

Serial-ATA Controller 0 [Enhanced]

This item appears only when you set the SATA Mode item to [IDE Mode].

- [Disabled] Disables the SATA function.
- [Enhanced] Set to [Enhanced] to support more than four SATA devices.
- [Compatible] Set to [Compatible] when using Windows 98/NT/2000/MS-DOS. Up to four SATA devices are supported under these operating systems.

Serial-ATA Controller 1 [Enhanced]

This item appears only when you set the SATA Mode item to [IDE Mode].

- [Disabled] Disables the SATA function.
- [Enhanced] Set to [Enhanced] to support more than four SATA devices.

S.M.A.R.T. Status Check [Enabled]

S.M.A.R.T. (Self-Monitoring, Analysis and Reporting Technology) is a monitor system. When read/write of your hard disk errors occur, this feature allows the hard disk to report warning messages during the POST. Configuration options: [Enabled] [Disabled]

Hot Plug [Disabled]

This item only appears when you set the SATA Mode Selection item to [AHCI Mode] or [RAID Mode] and allows you to enable or disable the hot-plug support for each SATA port. Configuration options: [Enabled] [Disabled]

3.4.6 Intel TXT(LT) Configuration

Secure Mode Extensions (SMX) [Enabled]

Allows you to enable or disable the Intel Secure Mode Extensions (SMX) technology. Configuration options: [Disabled] [Enabled]

Intel TXT(LT) Support [Disabled]

This item can be configured only when the Intel SMX, Intel Virtualization Technology (VT), and Intel Virtualization Technology for Directed I/O (VT-d) technologies are all enabled. Allows you to enable or disable the Intel Trusted Execution Technology. Configuration options: [Disabled] [Enabled]

3.4.7 USB Configuration

The items in this menu allow you to change the USB-related features.



NOTE: The **USB Devices** item shows the auto-detected values. If no USB device is detected, the item shows **None**.

Legacy USB Support [Enabled]

- [Enabled] Enables the support for USB devices on legacy operating systems (OS).
- [Disabled] The USB devices can be used only for the BIOS setup program.
- [Auto] Allows the system to detect the presence of USB devices at startup. If detected, the USB controller legacy mode is enabled. If no USB device is detected, the legacy USB support is disabled.

EHCI Hand-off [Disabled]

- [Enabled] Enables the support for operating systems without an EHCI hand-off feature.
- [Disabled] Disables the function.

3.4.8 ME Subsystem

The items in this menu allow you to change the Intel® Management Engine (ME) feature.

ME Subsystem [Enabled]

Allows you to enable or disable accessing the ME subsystem. Configuration options: [Enabled] [Disabled]

End of Post Message [Enabled]

This item appears only when you set the ME Subsystem item to [Enabled]. Configuration options: [Enabled] [Disabled]

Execute MEBx [Enabled]

Allows you to enable or disable the Intel® Management Engine BIOS Extension (MEBx) feature. Configuration options: [Enabled] [Disabled]

3.4.9 AMT Configuration

The items in this menu allow you to change the Intel® Active Management Technology (AMT) feature.

AMT [Enabled]

Allow you to enable or disable the Intel® Active Management Technology (AMT) feature. Configuration options: [Enabled] [Disabled]

Unconfigure AMT/ME [Disabled]

Sets this item to [Disabled] to unconfigure AMT/ME without using a password or set it to [Enabled] to use a password. Configuration options: [Enabled] [Disabled]

WatchDog Timer [Disabled]

When set to [Enabled], the WatchDog Timer will monitor the time taken for each task performed by a software or hardware. Configuration options: [Enabled] [Disabled]



NOTE: The following two items become configurable only when you set the **WatchDog Timer** item to [Enabled].

OS WatchDog Timer [0]

Use the <+> and <-> keys to adjust the value or key in a number directly.

BIOS WatchDog Timer [0]

Use the <+> and <-> keys to adjust the value or key in a number directly.

3.4.10 Onboard Devices Configuration

HD Audio Controller [Enabled]

[Enabled] Enables the High Definition Audio Controller.

[Disabled] Disables the controller.



NOTE: The following item appears only when you set the **HD Audio Controller** item to [Enabled].

Front Panel Type [HD]

Allows you to set the front panel audio connector (AAFP) mode to legacy AC'97 or high-definition audio depending on the audio standard that the front panel audio module supports.

[HD] Sets the front panel audio connector (AAFP) mode to high definition audio.

[AC97] Sets the front panel audio connector (AAFP) mode to legacy AC'97

Realtek LAN Controller [Enabled]

[Enabled] Enables the Realtek LAN controller.

[Disabled] Disables the controller.

Realtek PXE OPROM [Disabled]

This item appears only when you set the **Realtek LAN Controller** item to [Enabled] and allows you to enable or disable the PXE OptionRom of the Realtek LAN controller. Configuration options: [Enabled] [Disabled]

ASM1061 Storage Controller [IDE Mode]

Allows you to enable or disable the ASM1061 storage controller. Configuration options: [Disabled] [IDE Mode] [AHCI Mode]



NOTE: If you want to use the full function of the ASM1061 storage controller (ex. AHCI), we recommend that you set this item to [AHCI Mode] and install the **ASM1061 Controller Driver** from the motherboard support DVD.

Intel LAN Controller [Enabled]

[Enabled] Enables the Intel LAN controller.

[Disabled] Disables the controller.



NOTE: Disable ME subsystem before you disable the LAN controller.

Intel PXE OPROM [Disabled]

This item appears only when you set the previous item to [Enabled] and allows you to enable or disable the PXE OptionRom of the Intel LAN controller. Configuration options: [Enabled] [Disabled]

Serial Port Configuration

The sub-items in this menu allow you to set the serial port configuration.

Serial Port 1 [Enabled]

Allows you to enable or disable serial port (COM) 1. Configuration options: [Enabled] [Disabled]

RS Mode [RS232]

Allows you to configure the serial communications standard of serial port (COM) 1. Configuration options: [RS232] [RS422] [RS485]

Change Settings [IO=378h; IRQ=4]

Allows you to select the Parallel Port base address. Configuration options: [IO=378h; IRQ=4] [IO=2F8h; IRQ=3] [IO=3E8h; IRQ=4] [IO=2E8h; IRQ=3]

Serial Port 2 [Enabled]

Allows you to enable or disable serial port (COM) 2. Configuration options: [Enabled] [Disabled]

Change Settings [IO=2F8h; IRQ=3]

Allows you to select the Parallel Port base address. Configuration options: [IO=378h; IRQ=4] [IO=2F8h; IRQ=3] [IO=3E8h; IRQ=4] [IO=2E8h; IRQ=3]

Parallel Port [Enabled]

Allows you to enable or disable the parallel port (LPT). Configuration options: [Enabled] [Disabled]

Change Settings [Auto]

Allows you to select the Parallel Port base address. Configuration options: [Auto] [IO=378h; IRQ=5] [IO=378h; IRQ=5,6,7,9,10,11,12] [IO=278h; IRQ=5,6,7,9,10,11,12] [IO=3BCh; IRQ=5,6,7,9,10,11,12]

Device Mode [STD Printer Mode]

Allows you to set the Printer port mode. Configuration options: [STD Printer Mode] [SPP Mode] [EPP-1.9 and SPP Mode] [EPP-1.7 and SPP Mode] [ECP Mode] [ECP and EPP 1.9 Mode] [ECP and EPP 1.7 Mode]

3.4.11 APM

Restore AC Power Loss [Power Off]

- [Power On] The system goes into on state after an AC power loss.
- [Power Off] The system goes into off state after an AC power loss.
- [Last State] The system goes into either off or on state, whatever the system state was before the AC power loss.

Power On By PCIE/PCI [Disabled]

- [Disabled] Disables the PCIE/PCI devices to generate a wake event.
- [Enabled] Enables the PCIE/PCI devices to generate a wake event.

Power On By Ring [Disabled]

- [Disabled] Disables Ring to generate a wake event.
- [Enabled] Enables Ring to generate a wake event.

Power On By RTC [Disabled]

- [Disabled] Disables RTC to generate a wake event.
- [Enabled] When set to [Enabled], the items **RTC Alarm Date (Days)** and **Hour/Minute/Second** will become user-configurable with set values.

RTC Alarm Date (Days)

This item appears only when you set the previous item to [Enabled] and allows you to select RTC alarm time (days). When you set the time to zero, the RTC alarms everyday. Use <+> and <-> keys to adjust the time.

- Hour / - Minute / - Second

Allows you to set the RTC alarm time. Use <+> and <-> keys to adjust the time.

3.4.12 SIO GPIO

GPIO 1~8 [Input]

Allows you to configure the digital signal of the GPIO (General Purpose Input/Output) pins 1~8. Configuration options: [Input] [Output High] [Output Low]

3.4.13 Serial Port Console Redirection

Console Redirection [Enabled]

Enables or disables the console redirection feature. When enabled, it allows you to maintain a system from a remote location by redirecting keyboard input and text output through the serial port. Configuration options: [Enabled] [Disabled]

Terminal Type [VT-UTF8]

VT-UTF8 is the preferred terminal type for out-of-band management. The next best choice is VT100+ and then VT100. Configuration options: [VT100] [VT100+] [VT-UTF8] [ANSI]

3.5 Monitor menu

The Monitor menu displays the system temperature/power status, and allows you to change the fan settings.



Scroll down to display the following items:

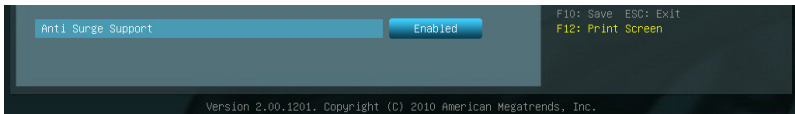

3.5.1 CPU Temperature / MB Temperature [xxx°C/xxx°F]

The onboard hardware monitor automatically detects and displays the CPU and motherboard temperatures. Select **Ignore** if you do not wish to display the detected temperatures.

3.5.2 CPU / Chassis Fan Speed [xxxx RPM] or [Ignore] / [N/A]

The onboard hardware monitor automatically detects and displays the CPU and chassis fan speeds in rotations per minute (RPM). If the fan is not connected to the motherboard, the field shows **N/A**. Select **Ignore** if you do not wish to display the detected speed.

3.5.3 CPU Q-Fan Control [Enabled]

[Disabled] Disables the CPU Q-Fan control feature.

[Enabled] Enables the CPU Q-Fan control feature.

CPU Fan Speed Low Limit [600 RPM]

This item appears only when you enable the **CPU Q-Fan Control** feature and allows you to disable or set the CPU fan warning speed. Configuration options:

[Ignore] [200 RPM] [300 RPM] [400 RPM] [500 RPM] [600 RPM]

CPU Fan Profile [Standard]

This item appears only when you enable the **CPU Q-Fan Control** feature and allows you to set the appropriate performance level of the CPU fan.

[Standard] Sets to [Standard] to make the CPU fan automatically adjust depending on the CPU temperature.

[Silent] Sets to [Silent] to minimize the fan speed for quiet CPU fan operation.

[Turbo] Sets to [Turbo] to achieve maximum CPU fan speed.

[Manual] Sets to [Manual] to assign detailed fan speed control parameters.



NOTE: The following four items appear only when you set **CPU Fan Profile** to [Manual].

CPU Upper Temperature [70]

Use the <+> and <-> keys to adjust the upper limit of the CPU temperature. The values range from 20°C to 75°C.

CPU Fan Max. Duty Cycle(%) [100]

Use the <+> and <-> keys to adjust the maximum CPU fan duty cycle. The values range from 20% to 100%. When the CPU temperature reaches the upper limit, the CPU fan will operate at the maximum duty cycle.

CPU Lower Temperature [20]

Use the <+> and <-> keys to adjust the lower limit of the CPU temperature. The values range from 20°C to 75°C.

CPU Fan Min. Duty Cycle(%) [20]

Use the <+> and <-> keys to adjust the minimum CPU fan duty cycle. The values range from 0% to 100%. When the CPU temperature is under 40°C, the CPU fan will operate at the minimum duty cycle.

3.5.4 Chassis Q-Fan Control [Enabled]

[Disabled] Disables the Chassis Q-Fan control feature.

[Enabled] Enables the Chassis Q-Fan control feature.

Chassis Fan Speed Low Limit [600 RPM]

This item appears only when you enable the **Chassis Q-Fan Control** feature and allows you to disable or set the chassis fan warning speed. Configuration options:

[Ignore] [200 RPM] [300 RPM] [400 RPM] [500 RPM] [600 RPM]

Chassis Fan Profile [Standard]

This item appears only when you enable the **Chassis Q-Fan Control** feature and allows you to set the appropriate performance level of the chassis fan.

[Standard]	Sets to [Standard] to make the chassis fan automatically adjust depending on the chassis temperature.
[Silent]	Sets to [Silent] to minimize the fan speed for quiet chassis fan operation.
[Turbo]	Sets to [Turbo] to achieve maximum chassis fan speed.
[Manual]	Sets to [Manual] to assign detailed fan speed control parameters.



NOTE: The following four items appear only when you set **Chassis Fan Profile** to [Manual].

Chassis Upper Temperature [70]

Use the <+> and <-> keys to adjust the upper limit of the CPU temperature. The values range from 40°C to 90°C.

Chassis Fan Max. Duty Cycle(%) [100]

Use the <+> and <-> keys to adjust the maximum chassis fan duty cycle. The values range from 60% to 100%. When the chassis temperature reaches the upper limit, the chassis fan will operate at the maximum duty cycle.

Chassis Lower Temperature [40]

Displays the lower limit of the chassis temperature.

CPU Fan Min. Duty Cycle(%) [60]

Use the <+> and <-> keys to adjust the minimum chassis fan duty cycle. The values range from 60% to 100%. When the chassis temperature is under 40°C, the chassis fan will operate at the minimum duty cycle.

3.5.5 CPU Voltage, 3.3V Voltage, 5V Voltage, 12V Voltage

The onboard hardware monitor automatically detects the voltage output through the onboard voltage regulators. Select **Ignore** if you do not want to detect this item.

3.5.6 Anti Surge Support [Enabled]

This item allows you to enable or disable the Anti Surge function.

Configuration options: [Disabled] [Enabled]

3.6 Boot menu

The Boot menu items allow you to change the system boot options.



3.6.1 Bootup NumLock State [On]

[On] Sets the power-on state of the NumLock to [On].

[Off] Sets the power-on state of the NumLock to [Off].

3.6.2 Full Screen Logo [Disabled]

[Enabled] Enables the full screen logo display feature.

[Disabled] Disables the full screen logo display feature.

3.6.3 Post Report [5 sec]

This item appears only when the Full Screen Logo item is set to [Disabled] and allows you to set the waiting time for the system to display the post report.

Configuration options: [1 sec] [2 sec] [3 sec] [4 sec] [5 sec] [6 sec] [7 sec] [8 sec] [9 sec] [10 sec] [Until Press ESC]

3.6.4 USB Boot Configuration [Enable All]

Allows you to set all the USB ports or a specific USB port as a bootable USB port.

Configuration options: [Enable All] [Only USB1] [Only USB2] [Only USB3] [Only USB4] [Only USB5] [Only USB6] [Only USB7] [Only USB8] [Only USB9] [Only USB10] [Only USB11] [Only USB12] [Only USB13] [Only USB14]

3.6.5 SATA Boot Configuration [Enable All]

Allows you to set all the SATA ports or a specific SATA port as a bootable SATA port. Configuration options: [Enable All] [Only SATA1] [Only SATA2] [Only SATA3] [Only SATA4] [Only SATA5] [Only SATA6]



NOTES:

SATA1: labeled **SATA6G_2** on this motherboard;

SATA2: labeled **SATA6G_3** on this motherboard;

SATA3: labeled **SATA3G_1** on this motherboard;

SATA4: labeled **SATA3G_2** on this motherboard;

SATA5: labeled **SATA3G_3** on this motherboard;

SATA6: labeled **SATA3G_4** on this motherboard.

3.6.6 Option ROM Messages [Force BIOS]

[Force BIOS] The third-party ROM messages will be forced to display during the boot sequence.

[Keep Current] The third-party ROM messages will be displayed only if the third-party manufacturer had set the add-on device to do so.

3.6.7 Boot Option Priorities

These items specify the boot device priority sequence from the available devices. The number of device items that appears on the screen depends on the number of devices installed in the system.



NOTES:

- To select the boot device during system startup, press <F8> after the first screen appears.
 - To access Windows OS in Safe Mode, press <F8> after POST.
-

3.6.8 Boot Override

These items displays the available devices. The number of device items that appears on the screen depends on the number of devices installed in the system. Click an item to start booting from the selected device.

3.7 Tools menu

The Tools menu items allow you to configure options for special functions. Select an item then press <Enter> to display the submenu.

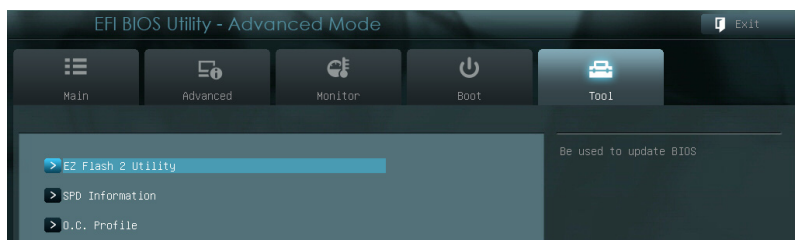

3.7.1 EZ Flash 2 Utility

Allows you to run EZ Flash 2. Press [Enter] to launch the EZ Flash 2 screen.

3.7.2 SPD Information

DIMM Slot # [Slot 1]

Displays the Serial Presence Detect (SPD) information of the DIMM module installed on the selected slot. Configuration options: [Slot 1] [Slot 2] [Slot 3] [Slot 4]



NOTES:

Slot 1: labeled **DIMM_A1** on this motherboard;

Slot 2: labeled **DIMM_A2** on this motherboard;

Slot 3: labeled **DIMM_B1** on this motherboard;

Slot 4: labeled **DIMM_B2** on this motherboard.

3.7.3 O.C. Profile

This item allows you to store or load multiple BIOS settings.



NOTE: The **Setup Profile Status** items show **Not Installed** if no profile is created.

Save to Profile

Allows you to save the current BIOS settings to the BIOS Flash, and create a profile. Key in a profile number from one to eight, press <Enter>, and then select **Yes**.

Load from Profile

Allows you to load the previous BIOS settings saved in the BIOS Flash. Key in the profile number that saved your CMOS settings, press <Enter>, and then select **Yes**.



NOTES:

- DO NOT shut down or reset the system while updating the BIOS to prevent the system boot failure!
 - We recommend that you update the BIOS file only coming from the same memory/CPU configuration and BIOS version.
-

3.8 Exit menu

The Exit menu items allow you to load the optimal default values for the BIOS items, and save or discard your changes to the BIOS items. You can access the EZ Mode from the Exit menu.

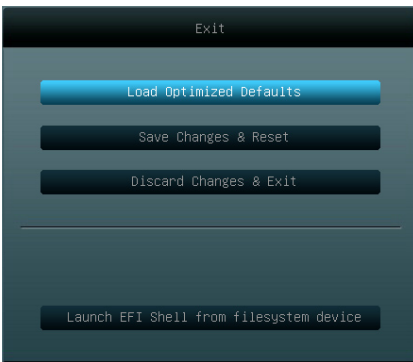

Load Optimized Defaults

This option allows you to load the default values for each of the parameters on the Setup menus. When you select this option or if you press <F5>, a confirmation window appears. Select Yes to load the default values.

Save Changes & Reset

Once you are finished making your selections, choose this option from the Exit menu to ensure the values you selected are saved. When you select this option or if you press <F10>, a confirmation window appears. Select Yes to save changes and exit.

Discard Changes & Exit

This option allows you to exit the Setup program without saving your changes. When you select this option or if you press <Esc>, a confirmation window appears. Select Yes to discard changes and exit.

Launch EFI Shell from filesystem device

This option allows you to attempt to launch the EFI Shell application (shellx64.efi) from one of the available devices that have a filesystem.

Appendix

Notices

Federal Communications Commission Statement

This device complies with Part 15 of the FCC Rules. Operation is subject to the following two conditions:

- This device may not cause harmful interference.
- This device must accept any interference received including interference that may cause undesired operation.

This equipment has been tested and found to comply with the limits for a Class B digital device, pursuant to Part 15 of the FCC Rules. These limits are designed to provide reasonable protection against harmful interference in a residential installation. This equipment generates, uses and can radiate radio frequency energy and, if not installed and used in accordance with manufacturer's instructions, may cause harmful interference to radio communications. However, there is no guarantee that interference will not occur in a particular installation. If this equipment does cause harmful interference to radio or television reception, which can be determined by turning the equipment off and on, the user is encouraged to try to correct the interference by one or more of the following measures:

- Reorient or relocate the receiving antenna.
- Increase the separation between the equipment and receiver.
- Connect the equipment to an outlet on a circuit different from that to which the receiver is connected.
- Consult the dealer or an experienced radio/TV technician for help.



WARNING! The use of shielded cables for connection of the monitor to the graphics card is required to assure compliance with FCC regulations. Changes or modifications to this unit not expressly approved by the party responsible for compliance could void the user's authority to operate this equipment.
