

EMB-Q170B

Industrial Motherboard

Copyright Notice

This document is copyrighted, 2024. All rights are reserved. The original manufacturer reserves the right to make improvements to the products described in this manual at any time without notice.

No part of this manual may be reproduced, copied, translated, or transmitted in any form or by any means without the prior written permission of the original manufacturer. Information provided in this manual is intended to be accurate and reliable. However, the original manufacturer assumes no responsibility for its use, or for any infringements upon the rights of third parties that may result from its use. The material in this document is for product information only and is subject to change without notice. While reasonable efforts have been made in the preparation of this document to assure its accuracy, the original manufacturer assumes no liabilities resulting from errors or omissions in this document, or from the use of the information contained herein.

The original manufacturer reserves the right to make changes in the product design without notice to its users.

Acknowledgments

All other products' name or trademarks are properties of their respective owners.

- AMI is a trademark of American Megatrends Inc.
- Intel®, Core™ are trademarks of Intel® Corporation.
- Microsoft Windows® is a registered trademark of Microsoft Corp.
- IBM, PC/AT, PS/2, and VGA are trademarks of International Business Machines Corporation.

The original manufacturer reserves the right to make changes in the product design without notice to its users.

All other product names or trademarks are properties of their respective owners.

Contents

Chapter 1: Product overview

1.1	Package contents.....	1-1
1.2	Features	1-1
1.3	Specifications.....	1-2

Chapter 2: Motherboard information

2.1	Before you proceed	2-1
2.2	Motherboard layout.....	2-2
2.3	Screw size.....	2-4
2.3.1	Component side.....	2-4
2.3.2	Solder side	2-5
2.4	Central Processing Unit (CPU)	2-6
2.4.1	Installing the CPU	2-7
2.4.2	CPU heatsink and fan assembly installation.....	2-9
2.5	System memory	2-11
2.5.1	Installing a DIMM	2-11
2.6	Jumpers	2-13
2.7	Onboard LEDs	2-17
2.8	Connectors	2-18
2.8.1	Rear panel connectors.....	2-18
2.8.2	Internal connectors	2-19

Chapter 3: BIOS setup

3.1	BIOS setup.....	3-1
3.1.1	Menu bar.....	3-2
3.2	Main menu	3-2
3.2.1	System Date [Day MM/DD/YYYY]	3-2
3.2.2	System Time [HH:MM:SS].....	3-2
3.3	Advanced menu	3-3
3.3.1	CPU Configuration	3-3
3.3.2	Trusting Computing.....	3-3
3.3.3	SATA Configuration	3-4
3.3.4	USB Configuration	3-5
3.3.5	Hardware Monitor	3-5
3.3.6	SIO Configuration	3-9
3.3.7	AMT Configuration.....	3-9
3.3.8	PCH-FW Configuration	3-10

3.3.9	Power Management.....	3-10
3.3.10	Digital IO Port Configuration	3-11
3.4	Chipset menu	3-11
3.4.1	System Agent (SA) Configuration	3-11
3.5	Security menu	3-12
3.5.1	Administrator Password	3-12
3.5.2	User Password.....	3-12
3.6	Boot menu	3-13
	Boot Configuration	3-13
3.7	Save & Exit menu	3-14
 Appendix		
	Notices.....	A-1

Chapter 1

Product overview

1.1 Package contents

Check your industrial motherboard package for the following items.

- 1 x Industrial Motherboard
- 1 x SATA cable
- 1 x SATA power cable
- 1 x I/O Shield
- 1 x Support CD



If any of the above items is damaged or missing, contact your distributor or sales representative immediately.

1.2 Features

- Intel® Socket 1151 for 6th/7th Generation Core™ i7/ Core™ i5/ Core™ i3, Pentium® and Celeron™ processors up to 65W
- 2 x SO-DIMM, max. 32GB, 260-pin DDR4 2133/1867 MHz, Non-ECC, Unbuffered Memory
- SATA 6.0 Gb/s x 4, USB3.0 x 4, USB2.0 x 6
- 1 x PCIe 3.0 [x4], 1 x M.2 M key (22 x 80mm) for PCIe [x4] / SATA at the bottom side, 1 x M.2 E key (22 x 30mm) for PCIe / USB / I2C-ME / SDIO / UART / PCM at mid-board
- DP, eDP, 18/24-bit Dual Channel LVDS support

1.3 Specifications

System	
Form factor	Mini-ITX
CPU	Intel® Socket 1151 for 6th/7th Generation Core™ i7/ Core™ i5/ Core™ i3, Pentium® and Celeron™ processors up to 65W
Chipset	Intel® Q170 Express Chipset
Memory	2 x SO-DIMM, Max. 32GB, 260-pin, DDR4 2133/1867 MHz, Non-ECC, Un-buffered Memory Dual channel memory architecture
I/O Chipset	NCT6791D
Storage	Intel® Q170 Express Chipset supports 4 x SATA 6.0Gb/s
Ethernet	1 x Intel PCIe Gb LAN 219LM for vPro 1 x Intel PCIe Gb LAN 211AT
Audio	Realtek® ALC887
TPM	Infineon SLB96XX TT 1.2 coay 2.0 (Default: No)
Expansion slot	1 x PCIe 3.0 [x4] 1 x M.2 M key (22 x 80mm) for PCIe[x4]/SATA at bottom side 1 x M.2 E key (22 x 30mm) for PCIe/USB/I2C-ME/SDIO/UART/PCM at top side
BIOS	128Mbit Flash ROM, AMI BIOS
Wake on LAN	Yes (WOL/PXE)
Watchdog Timer	1~255 steps by software program
H/W Status Monitor	Monitors CPU/Chassis temperature Monitors Vcore/5V/12V voltages Monitors CPU/Chassis fan speed
Smart Fan Control	CPU Fan / Chassis Fan
Power State	S3, S4, S5
Graphics	
Graphics Multi Display	2 x DP, 1 x eDP, 1 x LVDS
DP	Up to 4096 x 2160 MHz @ 24 Hz / 3840 x 2160 MHz @ 60 Hz, with Digital Audio
LVDS / eDP	LVDS: Up to 1920 x 1200 MHz @60 Hz, Dual Channel 18/24 bit eDP: UP to 4096 x 2340 MHz @ 60Hz (could only use 1 function at a time since only support 1 x inverter)
Backlight Control	Voltage / PWM
Environement & Power & ME	
Battery	Lithium battery
Power requirement	12V DC
Form Factor	Mini ITX Form Factor, 6.7" x 6.7" (170mm x 170mm)
Weight	1.1 lb (0.5 Kg)
Operating temperature	32°F~140°F (0°C~60°C)
Operating humidity	60°C @ 90% RH Non-Condensing
Certificate	CE/FCC (Class A)

(continued on the next page)

I/O	
Storage	4 x SATA 6.0Gb/s, supports RAID 0/1/5/10 1 X M.2 (M-key), (22 x 80mm) (PCIex4/SATA) 4-pin SATA power (5V, 12V @1A)
USB	4 x USB 3.0 ports (Rear IO) 6 x USB 2.0 ports (internal pin header)
Display I/O	2 x DP, 1 x eDP, 1 x LVDS
Audio I/O	Mic-in, Line-out, AAFP, internal speaker
LAN I/O	2 x RJ-45 ports
Serial port	1 x RS-232/422/485 supports 5V/12V/RI option (mid board)
DIO	8-bit Digital I/O interface (4-in / 4-out)
FAN	1 x CPU Fan connector (4-pin) 1 x Chassis Fan connector (4-pin)
Placement	
Back panel I/O ports	1 x DC Jack 2 x DP 2 x LAN (RJ-45) ports 4 x USB 3.0 ports 1 x Audio jack (Mic-In) pink connector 1 x Audio jack (Line-Out) green connector
Internal I/O connectors	1 x PCIe x4 slot 1 x M.2 M key (22 x 80mm) at bottom side 1 x M.2 E key (22 x 30mm) at top side 4 x SATA 6.0Gb/s ports 1 x 4-pin SATA power connector 3 x USB 2.0 pin header support additional 6 USB ports 1 x boxer header for COM (COM1: RS-232/422/485 supports 5V/12V/RI) 1 x 40-pin LVDS connector 1 x 40-pin eDP connector 1 x LVDS 3.3V / 5V jumper 1 x LCD DC / PWM mode jumper 1 x LCD backlight connector (inverter) 1 x LCD backlight 12V / 5V jumper 1 x Digital I/O box header 1 x 4-pin (2x2) internal power connector 1 x 4-pin CPU Fan connector 1 x 4-pin Chassis Fan connector 1 x Front Panel connector 1 x AAFP connector follows ASUS pin out 1 x Speaker connector for 2W/4Ω 1 x Chassis Intrusion connector 1 x Buzzer on board 1 x AT/ATX mode selection jumper 1 x Clear CMOS jumper

(continued on the next page)

Others	
OS support	Windows® 7 32-bit / 64-bit (not supported when using a Kaby Lake processor) Windows® 8.1 32-bit / 64-bit (not supported when using a Kaby Lake processor) Windows® 10 64-bit Linux Fedora
Accessories	1 x SATA cable 1 x SATA power cable 1 x I/O shield 1 x Support DVD



NOTE: Specifications are subject to change without notice.

Chapter 2

Motherboard information

2.1 Before you proceed

Take note of the following precautions before you install motherboard components or change any motherboard settings.



CAUTION!

- Unplug the power cord from the wall socket before touching any component.
 - Before handling components, use a grounded wrist strap or touch a safely grounded object or a metal object, such as the power supply case, to avoid damaging them due to static electricity.
 - Hold components by the edges to avoid touching the ICs on them.
 - Whenever you uninstall any component, place it on a grounded antistatic pad or in the bag that came with the component.
 - Before you install or remove any component, ensure that the ATX power supply is switched off or the power cord is detached from the power supply. Failure to do so may cause severe damage to the motherboard, peripherals, or components.
-

2.2 Motherboard layout



NOTE: Place four screws into the holes indicated by circles to secure the motherboard to the chassis.



CAUTION! Do not overtighten the screws! Doing so can damage the motherboard.

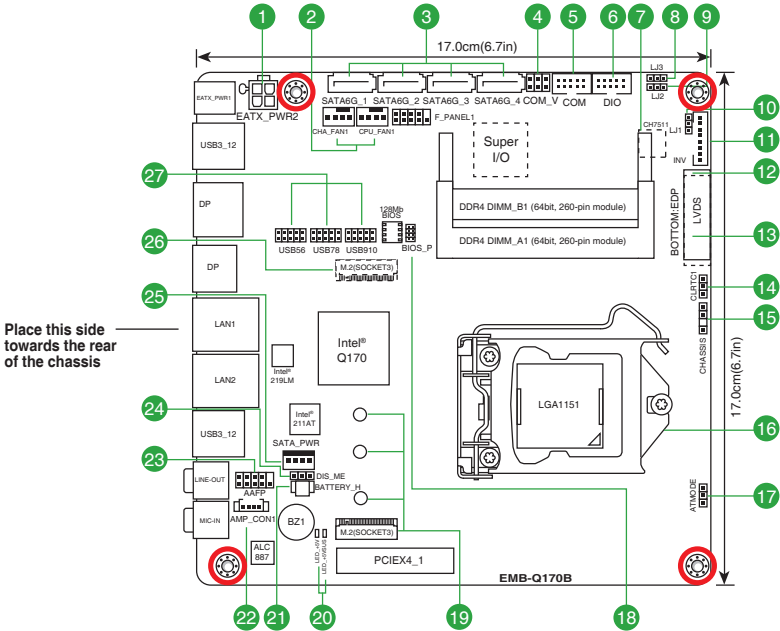

Connectors/Jumpers/Slots	Page
1. 12VDC connector (4-pin EATX_PWR2)	2-19
2. Chassis / CPU fan connectors (4-pin CPU_FAN1, 4-pin CHA_FAN1)	2-20
3. Serial ATA 6.0Gb/s connectors (7-pin SATA6G_1~4)	2-21
4. COM1 Ring/+5V/+12V selection (COM1_V1)	2-15
5. Serial port connectors (10-1 pin COM1)	2-25
6. Digital I/O connector (DIO)	2-26
7. SO-DIMM memory slots	2-11
8. Inverter backlight control mode selection (3-pin LJ3)	2-14
9. Inverter voltage selection (3-pin LJ2)	2-15
10. LVDS panel voltage selection (3-pin LJ1)	2-14
11. Backlight inverter power connector (5-pin INV1)	2-22
12. LVDS connector (40-pin LVDS1)	2-22
13. Embedded DisplayPort (40-pin eDP)	2-24
14. Clear RTC RAM (CLRRTC)	2-13
15. Chassis intrusion connector (4-1 pin CHASSIS)	2-16
16. Intel® LGA1151 CPU socket	2-6
17. ATMODE selection (3-pin)	2-17
18. BIOS programmable connector (8-pin BIOS_P)	2-23
19. M.2 E-Key (Top)	2-26
20. Standby Power LED (LED1_+5V, LED1_+5V SUS)	2-17
21. Battery connector (2-pin BATTERY_H)	2-19
22. Speaker out connector (AMP_CON1)	2-24
23. Front panel audio connector (10-1 pin AAFP)	2-20
24. Intel® ME Jumper (3-pin DIS_ME)	2-16
25. SATA power connector (SATA_PWR1)	2-21
26. M.2 M-Key (Bottom)	2-26
27. USB 2.0 connector (10-1 pin USB_56, USB_78 and USB_910)	2-23

2.3 Screw size

2.3.1 Component side

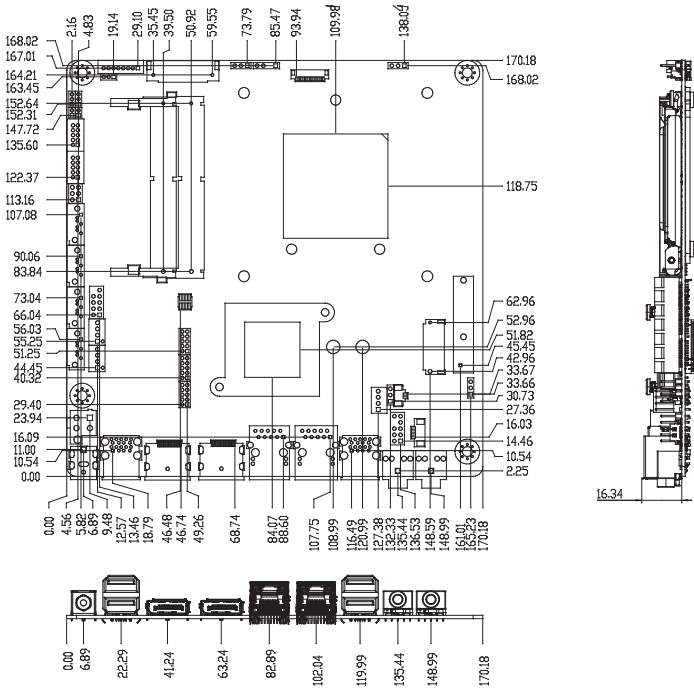

2.3.2 Solder side

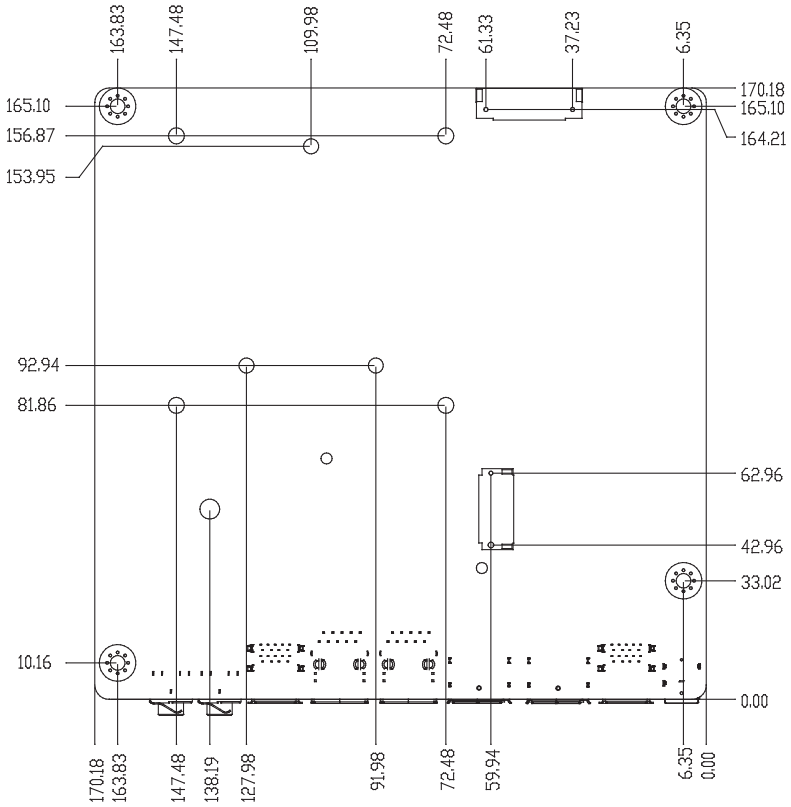

2.4 Central Processing Unit (CPU)

The motherboard comes with a surface mount LGA1151 socket designed for the Intel® 6th/7th Generation Core™ i7 / Core™ i5 / Core™ i3, Pentium® and Celeron® processors.

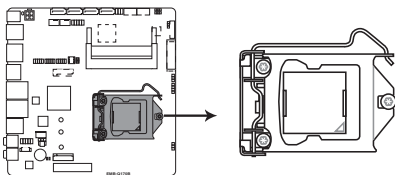

EMB-Q170B CPU socket LGA1151



IMPORTANT: Unplug all power cables before installing the CPU.



CAUTION!

- Upon purchase of the motherboard, ensure that the PnP cap is on the socket and the socket contacts are not bent. Contact your retailer immediately if the PnP cap is missing, or if you see any damage to the PnP cap/socket contacts/motherboard components. The manufacturer will shoulder the cost of repair only if the damage is shipment/transit-related.
 - Keep the cap after installing the motherboard. The manufacturer will process Return Merchandise Authorization (RMA) requests only if the motherboard comes with the cap on the LGA1151 socket.
 - The product warranty does not cover damage to the socket contacts resulting from incorrect CPU installation/removal, or misplacement/loss/incorrect removal of the PnP cap.
-

2.4.1 Installing the CPU



CAUTION! Ensure that you install the correct CPU designed for LGA 1151 only. DO NOT install a CPU designed for LGA1155 and LGA1156 sockets on the LGA1151 socket.

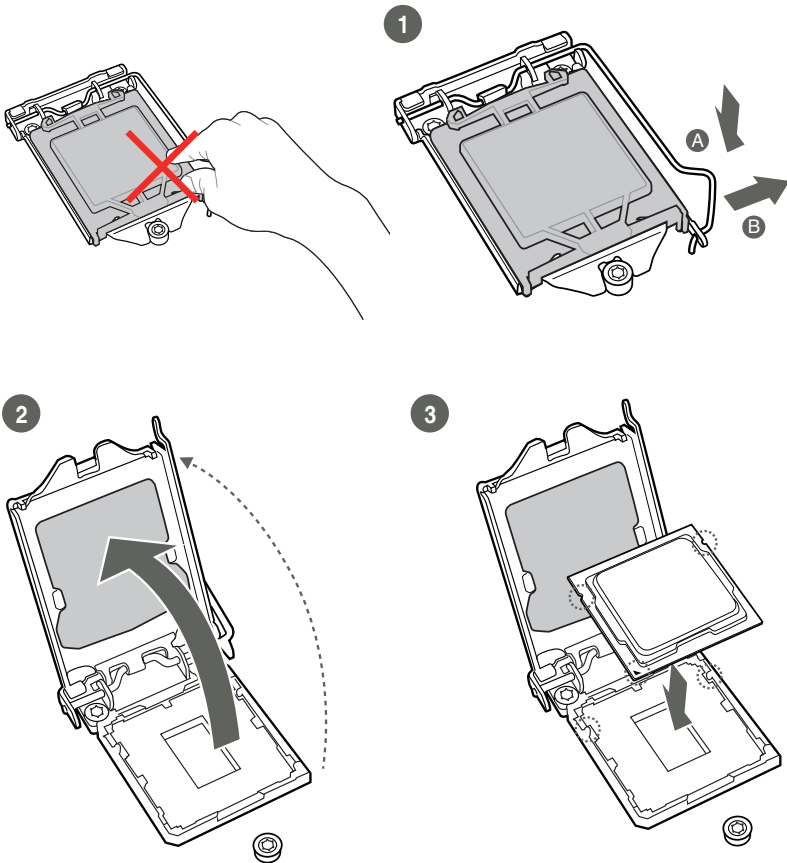

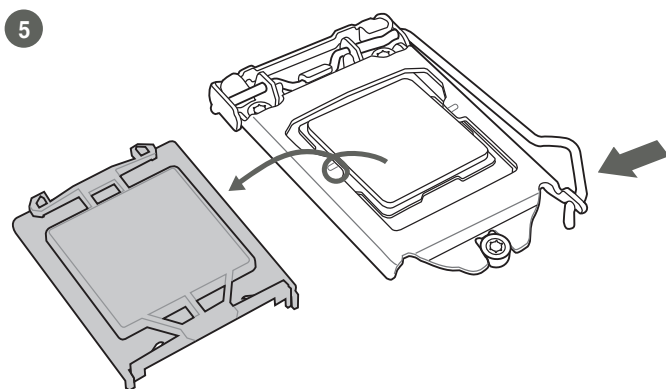
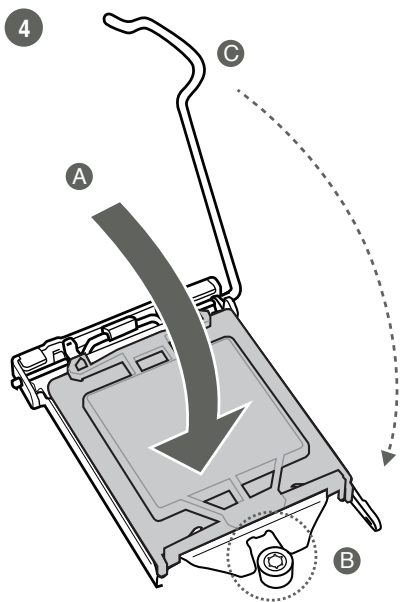

2.4.2 CPU heatsink and fan assembly installation

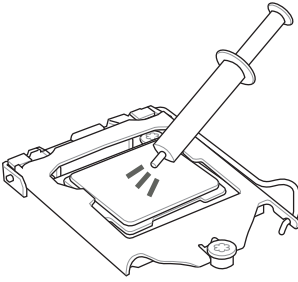

CAUTION! Apply the Thermal Interface Material to the CPU heatsink and fan before you install the heatsink and fan if necessary.

To install the CPU heatsink and fan assembly

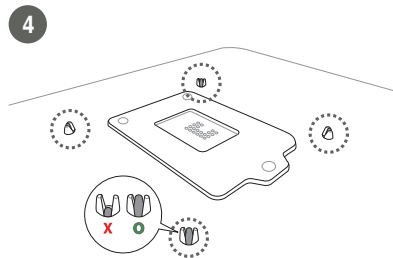
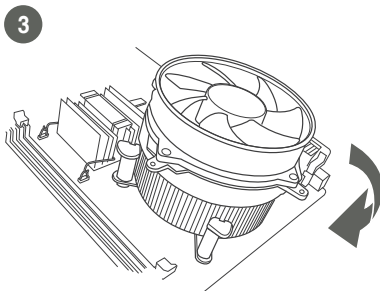
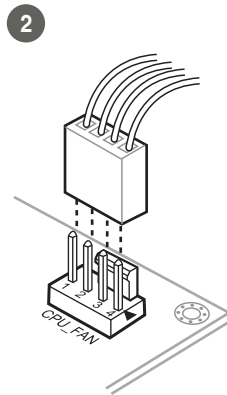
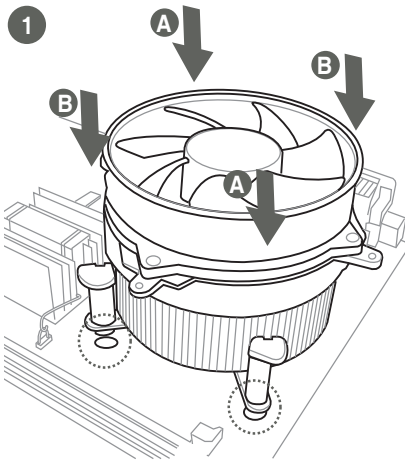

To uninstall the CPU heatsink and fan assembly

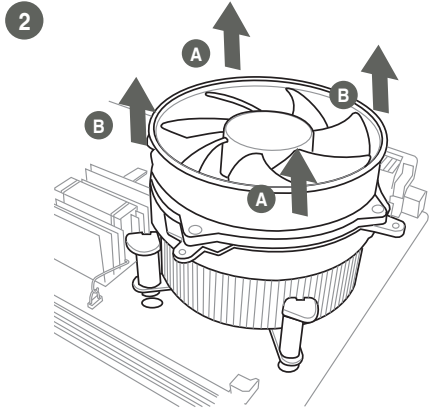
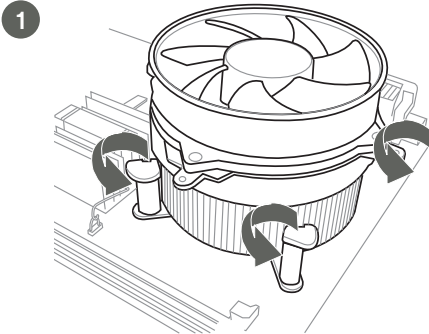

2.5 System memory

This motherboard comes with two Double Data Rate 4 (DDR4) Small Outline Dual Inline Memory Modules (SO-DIMM) sockets. The figure illustrates the location of the DDR4 SO-DIMM sockets:

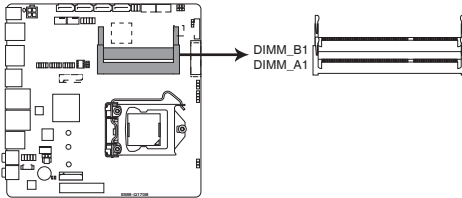

EMB-Q170B 260-pin DDR4 SO-DIMM sockets

2.5.1 Installing a DIMM

To install a SO-DIMM

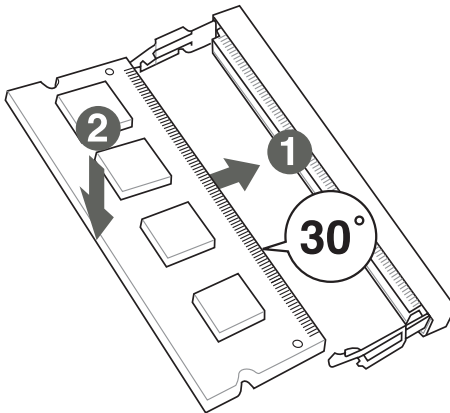

To remove a SO-DIMM

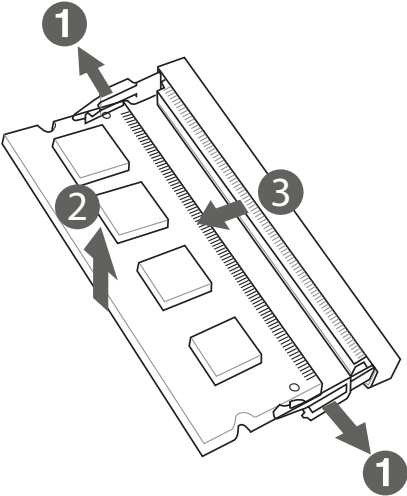

2.6 Jumpers

1. Clear RTC RAM (CLRRTC)

This jumper allows you to clear the Real Time Clock (RTC) RAM in CMOS. You can clear the CMOS memory of system setup parameters by erasing the CMOS RTC RAM data. The onboard button cell battery powers the RAM data in CMOS, which include system setup information such as system passwords.

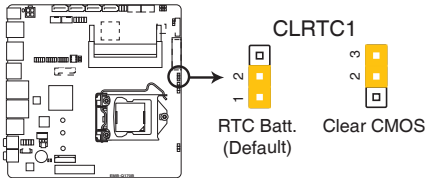

EMB-Q170B Clear RTC RAM

To erase the RTC RAM:

1. Turn OFF the computer and unplug the power cord.
2. Move the jumper cap from pins 1-2 (default) to pins 2-3. Keep the cap on pins 2-3 for about 5~10 seconds, then move the cap back to pins 1-2.
3. Plug the power cord and turn ON the computer.
4. Hold down the key during the boot process and enter BIOS setup to reenter data.



CAUTION! Except when clearing the RTC RAM, never remove the cap on CLRRTC jumper default position. Removing the cap will cause system boot failure!



NOTES:

- If the steps above do not help, remove the onboard battery and move the jumper again to clear the CMOS RTC RAM data. After clearing the CMOS, reinstall the battery.
 - You do not need to clear the RTC when the system hangs due to overclocking. For system failure due to overclocking, use the CPU Parameter Recall (C.P.R) feature. Shut down and reboot the system so the BIOS can automatically reset parameter settings to default values.
-

2. LVDS panel voltage selector (3-pin LJ1)

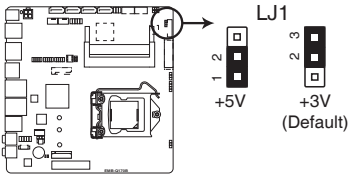

EMB-Q170B LVDS Panel Voltage Selection

Setting	Pins
+5V	1-2
+3.3V (Default)	2-3

3. Inverter Voltage Selection (3-pin LJ3)

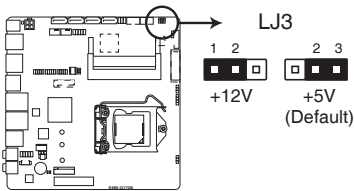

EMB-Q170B Inverter Voltage Selection

Setting	Pins
+12V	1-2
+5V (Default)	2-3

4. Inverter Backlight Control Mode selection (3-pin J2)

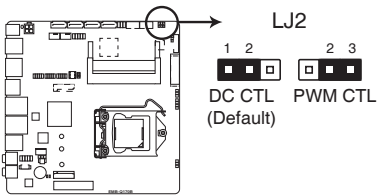

EMB-Q170B Inverter Backlight Control Mode selection

Setting	Pins
DC Voltage Control (Default)	1-2
PWM Control	2-3

5. COM1 Ring/+5V/+12V selector (6-pin COM1_V1)

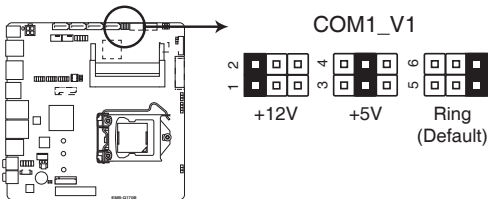

EMB-Q170B COM1 Ring/+5V/+12V Selection

Setting	Pins
+12V	1-2
+5V	3-4
Ring (Default)	5-6

6. Chassis intrusion header (4-1 pin CHASSIS)

This connector is for a chassis-mounted intrusion detection sensor or switch. Connect one end of the chassis intrusion sensor or switch cable to this connector. The chassis intrusion sensor or switch sends a high-level signal to this connector when a chassis component is removed or replaced. The signal is then generated as a chassis intrusion event.

By default, the pin labeled “Chassis Signal” and “Ground” are shorted with a jumper cap. Remove the jumper caps only when you intend to use the chassis intrusion detection feature.

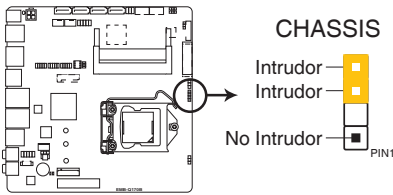

EMB-Q170B Chassis intrusion connector

7. Intel® ME Jumper (3-pin DIS_ME)

This jumper allows you to force the Intel® Management Engine (ME) to boot to recovery mode when ME becomes corrupted.

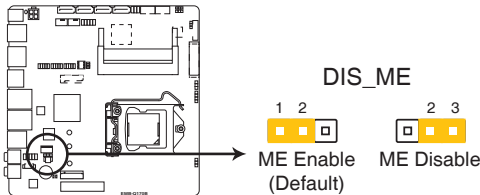

EMB-Q170B Intel® ME jumper

8. AT/ATX mode selection (3-pin AT_ATX)

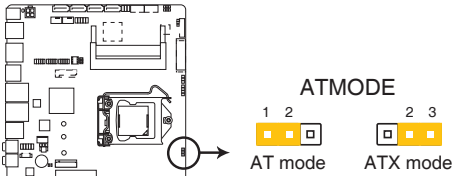

EMB-Q170B AT/ATX mode selection

	Pins
AT mode	1-2
ATX mode	2-3

2.7 Onboard LEDs

1. Standby Power LED

The motherboard comes with a standby power LED that lights up to indicate that the system is ON, in sleep mode, or in soft-off mode. This is a reminder that you should shut down the system and unplug the power cable before removing or plugging in any motherboard component. The illustration below shows the location of the onboard LED.

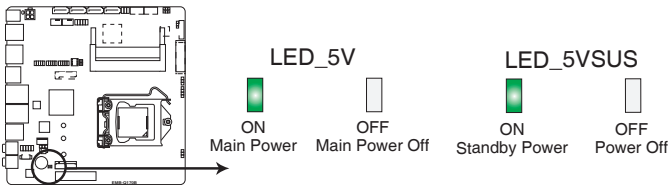

EMB-Q170B Onboard LEDs

2.8 Connectors

2.8.1 Rear panel connectors

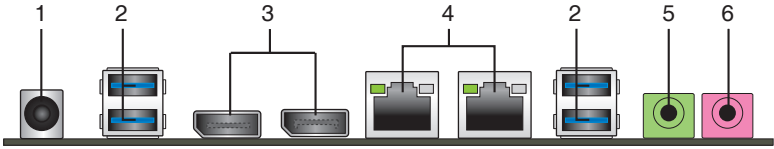

1. **DC power connector.** Insert the power adapter into this port.
2. **USB 3.0 ports.** These two 9-pin Universal Serial Bus (USB) ports connect to USB 3.0/2.0 devices.



NOTES:

- DO NOT connect a keyboard / mouse to any USB 3.0 port when installing Windows® operating system.
- Due to USB 3.0 controller limitation, USB 3.0 devices can only be used under Windows® OS environment and after the USB 3.0 driver installation.
- USB 3.0 devices can be used for data storage only.
- We strongly recommend that you connect USB 3.0 devices to USB 3.0 ports for a faster and better performance from your USB 3.0 devices.

3. **DisplayPort connectors.** This port connects a device with DisplayPort connector.
4. **LAN2 (RJ-45) ports.** This port allows Gigabit connection to a Local Area Network (LAN) through a network hub. Refer to the table below for the LAN2 port LED indications.

LAN port LED indications

ACT/LINK LED		SPEED LED	
Status	Description	Status	Description
OFF	No link	OFF	10 Mbps connection
ORANGE	Linked	ORANGE	100 Mbps connection
BLINKING	Data activity	GREEN	1 Gbps connection

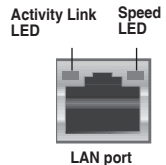

5. **Line Out port (lime).** This port connects to a headphone or a speaker.
6. **Microphone port (pink).** This port connects to a microphone.

2.8.2 Internal connectors

1. 12VDC power connectors (4-pin EATX_PWR1)

This connector is for an EATX power supply plug. The power supply plug is designed to fit this connector in only one orientation. Find the proper orientation and push down firmly until the connector completely fits.

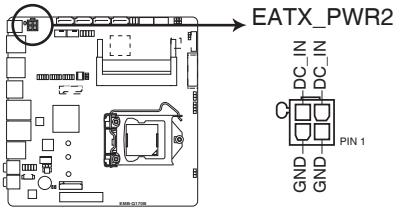

EMB-Q170B 1 x 4 PIN (2x2) internal power connector



IMPORTANT:

- For a fully configured system, we recommend that you use a power supply unit (PSU) that complies with ATX 12V Specification 2.0 (or later version).
- DO NOT forget to connect the 4-pin ATX +12V power plug. Otherwise, the system will not have enough power.
- We recommend that you use a PSU with higher power output when configuring a system with more power-consuming devices. The system may become unstable or may not boot up if the power is inadequate.

2. Battery connector (2-pin BATTERY1)

This connector is for the lithium CMOS battery.

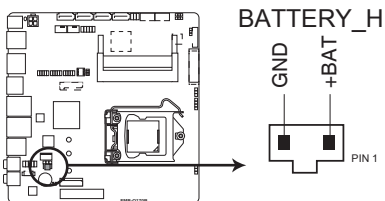

EMB-Q170B Battery Holder connector

3. Chassis / CPU fan connectors (4-pin CHA_FAN1, 4-pin CPU_FAN1)

Connect the fan cables to the fan connectors on the motherboard, ensuring that the black wire of each cable matches the ground pin of the connector.

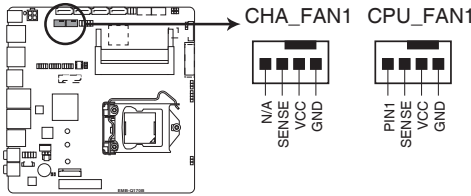

EMB-Q170B Fan connectors



CAUTION: Do not forget to connect the fan cables to the fan connectors. Insufficient air flow inside the system may damage the motherboard components. These are not jumpers! Do not place jumper caps on the fan connectors!

4. Front panel audio connector (10-1 pin AAFP)

This connector is for a chassis-mounted front panel audio I/O module that supports either HD Audio or legacy AC'97 standard. Connect one end of the front panel audio I/O module cable to this connector.

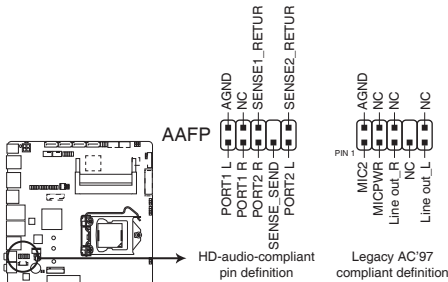

EMB-Q170B Front panel audio connector



IMPORTANT: We recommend that you connect a high-definition front panel audio module to this connector to avail of the motherboard's high-definition audio capability.

5. Serial ATA 6.0Gb/s connector (7-pin SATA6G_1~4)

This connector connects to Serial ATA 6.0 Gb/s hard disk drives via Serial ATA 6.0 Gb/s signal cables.

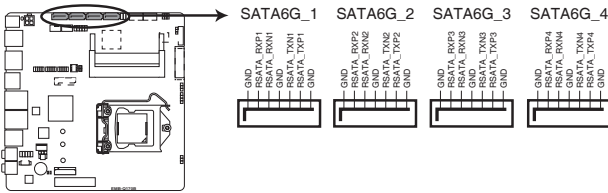

EMB-Q170B SATA 6.0Gb/s connectors



IMPORTANT:

- You must install Windows® 7 or later version before using Serial ATA hard disk drives.
- When using hot-plug and NCQ, set the SATA Mode Selection item in the BIOS to [AHCI]. See section 3.3.7 IDE Configuration for details.

6. SATA power connector (4-pin SATA_PWR1)

This connector is for the SATA power cable. The power cable plug is designed to fit this connector in only one orientation. Find the proper orientation and push down firmly until the connector completely fits.

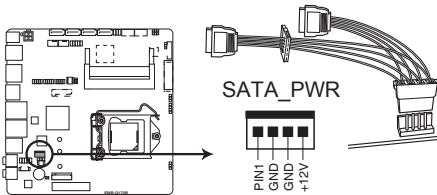

EMB-Q170B SATA POWER connector



IMPORTANT: The SATA power connector supports 1A current to the maximum.

7. LVDS connector (40-pin LVDS1)

This connector is for an LCD monitor that supports Low-Voltage Differential Signaling (LVDS) interface.

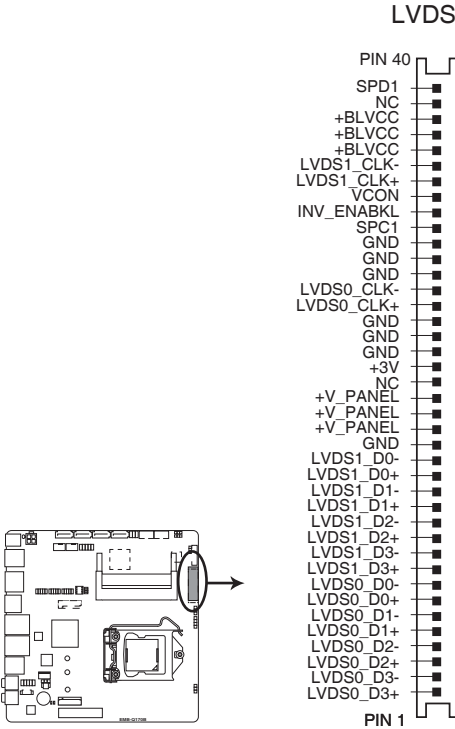

EMB-Q170B LVDS connector

8. Backlight inverter power connector (8-pin INV)

Connect the backlight inverter power cable to this connector.

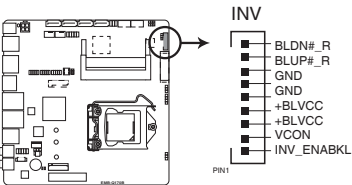

EMB-Q170B Inverter connector



IMPORTANT: The backlight inverter power connector supports 1A current to the maximum.

9. USB 2.0 connector (10-1 pin USB_56, USB_78 and USB_910)

These USB connectors comply with USB 2.0 specifications.

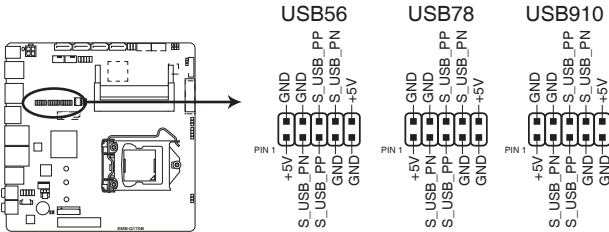

EMB-Q170B USB2.0 connectors



Never connect a 1394 cable to the USB connector. Doing so will damage the motherboard.



NOTES:

- The USB module cable is purchased separately.
- Before you install Windows 7 operating system, go to BIOS Setup > Advanced > XHCI mode [Disabled], USB 2.0 (EHCI) support [Enabled], and set them back when you finish installing the operating system.
- Intel(R) has released an official Windows(R) 7 XHCI Driver Creator Utility, please download it from: <https://downloadcenter.intel.com/download/25476/Windows-7-USB-3-0-Creator-Utility>.

To install Windows(R) 7 in the Skylake platform:

Step1. Use this utility to pack XHCI driver into the original win7 OS image, there will be another OS image released.

Step2. Use the new OS image to install via any device.

10. BIOS programmable connector (8-pin SPI)

Use this connector to flash the BIOS ROM.

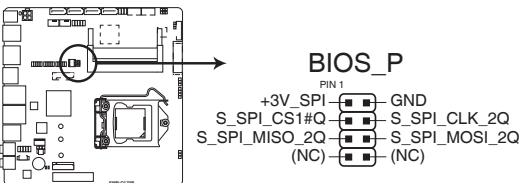

EMB-Q170B SPI flash Programmable connector

11. Embedded DisplayPort connector (40-pin eDP)

This connector is for an internal embedded DisplayPort connection.

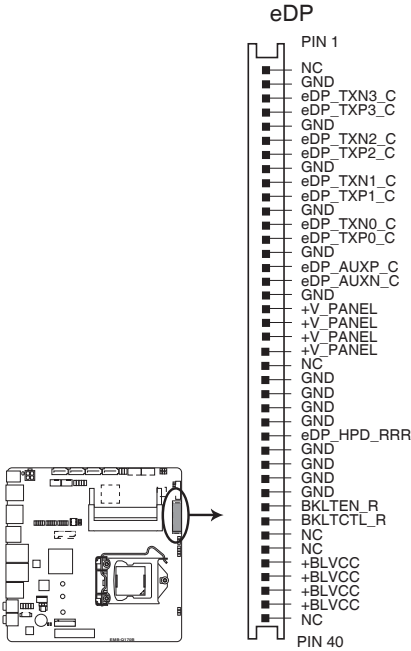

EMB-Q170B Embedded Display Port

12. Speaker out connector (4-pin AMP_CON1)

The 4-pin connector is for the chassis-mounted speaker.

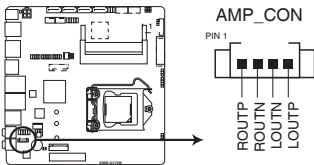

EMB-Q170B Audio Stere. Output with Amp connector



NOTE: The Speaker module is purchased separately.

13. Serial port connectors (10-1 pin COM1)

These connectors are for serial (COM) ports. Connect the serial port module cable to this connector, then install the module to a slot opening at the back of the system chassis.

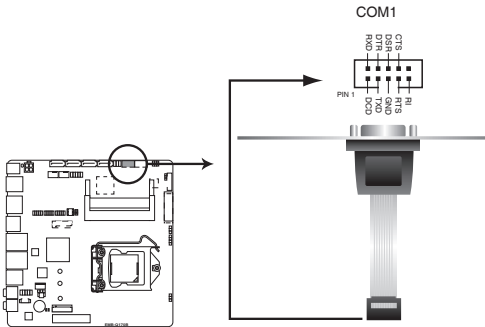

EMB-Q170B Serial port connector



NOTE:

- The COM module is purchased separately.
- COM1 also supports RS-232 / RS-422 / RS-485. See the table below and section **3.3.2 Super IO Configuration** for details.

Pin	Signal	Pin	Signal
1	DCD (422TXD-/485DATA-)	2	RXD (422RXD+)
3	TXD (422TXD+/485DATA+)	4	DTR (422RXD-)
5	GND	6	DSR
7	RTS	8	CTS
9	RI/+12V/+5V	10	N.C.

14. Digital I/O connector (10-pin DIO1)

This connector includes 8 I/O lines (In/Out programmable). All of the Digital I/O lines are programmable and each I/O pin can be individually programmed to support various devices.

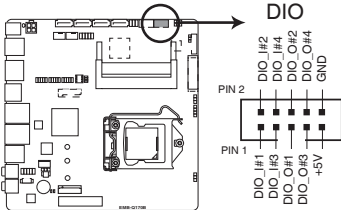

EMB-Q170B DIO connector

15. M.2 E-Key (Top)

This socket allows you to install an M.2 (NGFF) PCIe/USB/I2C-ME/SDIO/UART/PCM module.

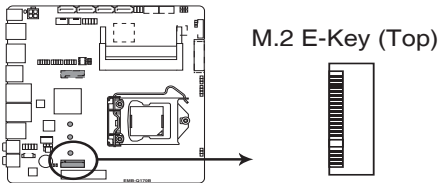

EMB-Q170B M.2 E-Key (Top)

16. M.2 Socket 3 (Bottom)

This socket allows you to install an M.2 (NGFF) SSD module.

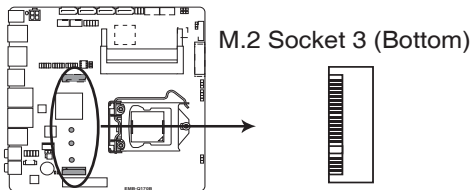

EMB-Q170B M.2 Socket 3 (Bottom)

Chapter 3

BIOS setup

3.1 BIOS setup

Use the BIOS Setup to update the BIOS or configure settings. The BIOS screens include navigation keys and help to guide you in using the BIOS Setup program.

Entering BIOS Setup at startup

To enter BIOS Setup at startup:

Press <Delete> during the Power-On Self Test (POST). If you do not press <Delete>, POST continues with its routine.

Entering BIOS Setup after POST

To enter BIOS Setup after POST:

- Press <Ctrl>+<Alt>+ simultaneously.
- Press the reset button on the system chassis.
- Press the power button to turn the system off then back on. Do this option only if you failed to enter BIOS Setup using the first two options.



NOTE: Using the power button, reset button, or the <Ctrl>+<Alt>+ keys to reboot a running operating system can cause damage to your data or system. Always shut down the system properly from the operating system.



IMPORTANT:

- The default BIOS settings for this motherboard apply to most working conditions and ensures optimal performance. If the system becomes unstable after changing any BIOS settings, load the default settings to regain system stability. Select the option **Restore Defaults** under the Save & Exit Menu. See section **3.7 Exit Menu**.
 - The BIOS setup screens shown in this section are for reference purposes only, and may not exactly match what you see on your screen.
-

3.1.1 Menu bar

The menu bar on top of the screen has the following main items:

Main	For changing the basic system configuration.
Advanced	For changing the advanced system settings.
Chipset	For viewing and changing chipset settings.
Security	For setting up BIOS security settings.
Boot	For changing the system boot configuration.
Save & Exit	For selecting the exit options and loading default settings.

To select an item on the menu bar, press the right or left arrow key on the keyboard until the desired item is highlighted.

3.2 Main menu

The Main menu provides you an overview of the basic system information, and allows you to set the system date, time, language, and security settings.

3.2.1 System Date [Day MM/DD/YYYY]

Allows you to set the system date.

3.2.2 System Time [HH:MM:SS]

Allows you to set the system time.

3.3 Advanced menu

The Advanced menu items allow you to change the settings for the CPU and other system devices.



Be cautious when changing the settings of the Advanced menu items. Incorrect field values can cause the system to malfunction.

Case Open Warning [Disabled]

Allows you to enable or disable case open warning function. Configuration options: [Disabled] [Enabled] [Clear]

3.3.1 CPU Configuration

The items in this menu show CPU-related information.

Hyper-threading [Enabled]

The Intel Hyper-Threading Technology allows a hyper-threading processor to appear as two logical processors to the operating system, allowing the operating system to schedule two threads or processes simultaneously.

[Enabled] Two threads per activated core are enabled.

[Disabled] Only one thread per activated core is enabled.

Intel Virtualization Technology [Enabled]

[Enabled] Allows a hardware platform to run multiple operating systems separately and simultaneously, enabling one system to virtually function as several systems.

[Disabled] Disables this function.

3.3.2 Trusting Computing

Security Device Support [Enable]

Allows you to enable or disable BIOS support for security devices. Configuration options: [Disable] [Enable]

TPM State [Enabled]

This item appears only when you set the **TPM Support** item to [Enabled] and allows you to enable or disable the TPM after POST. Reboot your system for the changes to take effect. Configuration options: [Disabled] [Enabled]

Pending operation [None]

Allows you to schedule an operation for security devices. Reboot your system for the changes to take effect. Configuration options: [None] [TPM Clear]

Device Select [Auto]

Allows you to schedule an operation for security devices. Reboot your system for the changes to take effect. Configuration options: [Auto] [TPM 1.2] [TPM 2.0]

- [Auto] Select this item to support both TPM 1.2 and TPM 2.0 devices with default support of TPM 2.0 devices. If TPM 2.0 devices are not found, TPM 1.2 devices will be enumerated.
- [TPM 1.2] Select this item to support TPM 1.2 devices only.
- [TPM 2.0] Select this item to support TPM 2.0 devices only.

3.3.3 SATA Configuration

SATA Controller(s) [Enabled]

Allows you to enable or disable SATA devices. Configuration options: [Enabled] [Disabled]

SATA Mode Selection [AHCI]

Allows you to set the SATA configuration.

- [AHCI] Set to [AHCI] when you want the SATA hard disk drives to use AHCI (Advanced Host Controller Interface). AHCI allows the onboard storage driver to enable advanced Serial ATA features that increases storage performance on random workloads by allowing the drive to internally optimize the order of commands.
- [RAID] Set to [RAID] when you want to create a RAID configuration from the SATA hard disk drives.

Serial-ATA Port 0~3

Allows you to enable or disable Serial-ATA Ports.

Port 0/1/2/3 [Enabled]

Configuration options: [Enabled] [Disabled]

Hot Plug [Disabled]

Configuration options: [Enabled] [Disabled]

M.2 SATA Port

Allows you to enable or disable Serial-ATA Ports.

M.2 Port [Enabled]

Configuration options: [Enabled] [Disabled]

Hot Plug [Disabled]

Configuration options: [Enabled] [Disabled]

3.3.4 USB Configuration



The USB Devices item lists auto-detected values. If no USB device is detected, the item shows None.

Legacy USB Support [Enabled]

- [Enabled] Enables the support for USB devices on legacy operating systems (OS).
- [Disabled] USB devices are only available when running BIOS Setup.
- [Auto] Allows the system to detect the presence of USB devices at startup. If detected, the USB controller legacy mode is enabled. If no USB device is detected, the legacy USB support is disabled.

XHCI Hand-off [Enabled]

- [Enabled] Enables the support for operating systems without an XHCI hand-off feature.
- [Disabled] Disables the XHCI Hand-off support.

3.3.5 Hardware Monitor

Smart Fan Configuration

The sub-items in this menu configure available fans on the system.

CPU Smart Fan Control [Enabled]

Enables or disables CPU Smart Fan Function. Configuration options: [Enabled] [Disabled]

Fan Control Mode [SMART FAN IV Mode]

Select fan control mode. Configuration options: [Manual Mode] [Thermal Cruise Mode] [SMART FAN IV Mode]



The following 9 items appear only when you set Fan Control Mode to [Smart FAN IV Mode].

Temperature 1~4 [xx]

Input temperature setting. The values range from 0~255.

Fan PWM 1~4 [xx]

Input amount of Fan PWM 4 for Smart Fan IV Mode. The values range from 0~255.

Tolerance of Temperature 1~4 [xx]

Input tolerance of target temperature. The values range from 0~7.

Critical Temperature [xx]

Determines the time that Fan Out takes to decrease its value by one step. The values range from 0~255.

Critical Temp Tolerance [xx]

Input tolerance of critical temperature. The values range from 0~7.

Fan Count Step Up [xx]

Input fan count up unit. The values range from 0~15.

Fan Count Step Down [xx]

Input fan count down unit. The values range from 0~15.

Fan Out Step Up Time [xx]

Input the time that Fan Out takes to increase its value by one step with an interval of 0.1 second. The values range from 0~15.

Fan Out Step Down Time [xx]

Input the time that Fan Out takes to decrease its value by one step with an interval of 0.1 second. The values range from 0~15.



The following item appears only when you set Fan Control Mode to [Smart FAN IV Mode].

PWM/DC Voltage Output [xx]

Input a PWM/DC voltage output value. The values range from 0~255.



The following 9 items appear only when you set Fan Control Mode to [Thermal Cruise Mode].

Target Temperature [xx]

Input the fan control target temperature. The values range from 0~127.

Tolerance of Temperature [xx]

Input tolerance of target temperature. The values range from 0~7.

Fan Out Start-Up Value [xx]

Input fan out start-up value. The values range from 0~127.

Fan Stop Duty [Down to 0]

Select the fan stop duty. Configuration options: [Down to 0] [To Fan Out Stop Value]

Fan Out Stop Duty [xx]

The Fan Out value decreases to this value if the temperature is below the lower

temperature limit. The values range from 0~255.

Fan Out Stop Time [xx]

Determines the time it takes Fan Out value to fall from the stop value to 0. The values range from 0~255.

Critical Temperature [xx]

Determines the time that Fan Out takes to decrease its value by one step. The values range from 0~255.

Fan Out Step Up Time [xx]

Determines the time that Fan Out takes to increase its value by one step with an interval of 0.1 second. The values range from 0~255.

Fan Out Step Down Time [xx]

Determines the time that Fan Out takes to decrease its value by one step with an interval of 0.1 second. The values range from 0~255.

Smart Fan Configuration

The sub-items in this menu configure available fans on the system.

System Smart Fan Control [Enabled]

Enables or disables system smart fan function. Configuration options: [Enabled] [Disabled]

Fan Control Mode [SMART FAN IV Mode]

Select fan control mode. Configuration options: [Manual Mode] [Thermal Cruise Mode] [SMART FAN IV Mode]



The following 9 items appear only when you set Fan Control Mode to [Smart FAN IV Mode].

Temperature 1~4 [xx]

Input temperature setting. The values range from 0~255.

Fan PWM 1~4 [xx]

Input amount of Fan PWM 4 for Smart Fan IV Mode. The values range from 0~255.

Tolerance of Temperature 1~4 [xx]

Input tolerance of target temperature. The values range from 0~7.

Critical Temperature [xx]

Determines the time that Fan Out takes to decrease its value by one step. The values range from 0~255.

Critical Temp Tolerance [xx]

Input tolerance of critical temperature. The values range from 0~7.

Fan Count Step Up [xx]

Input fan count up unit. The values range from 0~15.

Fan Count Step Down [xx]

Input fan count down unit. The values range from 0~15.

Fan Out Step Up Time [xx]

Input the time that Fan Out takes to increase its value by one step with an interval of 0.1 second. The values range from 0~15.

Fan Out Step Down Time [xx]

Input the time that Fan Out takes to decrease its value by one step with an interval of 0.1 second. The values range from 0~15.



The following item appears only when you set Fan Control Mode to [Smart FAN IV Mode].

PWM/DC Voltage Output [xx]

Input a PWM/DC voltage output value. The values range from 0~255.



The following 9 items appear only when you set Fan Control Mode to [Thermal Cruise Mode].

Target Temperature [xx]

Input the fan control target temperature. The values range from 0~127.

Tolerance of Temperature [xx]

Input tolerance of target temperature. The values range from 0~7.

Fan Out Start-Up Value [xx]

Input fan out start-up value. The values range from 0~127.

Fan Stop Duty [Down to 0]

Select the fan stop duty. Configuration options: [Down to 0] [To Fan Out Stop Value]

Fan Out Stop Duty [xx]

The Fan Out value decreases to this value if the temperature is below the lower temperature limit. The values range from 0~255.

Fan Out Stop Time [xx]

Determines the time it takes Fan Out value to fall from the stop value to 0. The

values range from 0~255.

Critical Temperature [xx]

Determines the time that Fan Out takes to decrease its value by one step. The values range from 0~255.

Fan Out Step Up Time [xx]

Determines the time that Fan Out takes to increase its value by one step with an interval of 0.1 second. The values range from 0~255.

Fan Out Step Down Time [xx]

Determines the time that Fan Out takes to decrease its value by one step with an interval of 0.1 second. The values range from 0~255.

3.3.6 SIO Configuration

Serial Port 1

The sub-items in this menu allow you to set the serial port configuration.

Use This Device [Enabled]

Allows you to enable or disable the serial port (COM). Configuration options: [Enabled] [Disabled]

Possible [Use Automatic Settings]

Allows you to select the Serial Port base address. Configuration options: [Use Automatic Settings] [IO=3F8h; IRQ=4] [IO=2F8h; IRQ=3;]

Mode [RS232]

Allows you to select COM RS Mode. Configuration options: [RS232] [RS422] [RS485]

Serial Port 2~6

The sub-items in this menu allow you to set the serial port configuration.

Use This Device [Enabled]

Allows you to enable or disable the serial port (COM). Configuration options: [Enabled] [Disabled]

Possible [Use Automatic Settings]

Allows you to select the Serial Port base address. Configuration options: [Use Automatic Settings] [IO=3F8h; IRQ=4] [IO=2F8h; IRQ=3;]

3.3.7 AMT Configuration

Intel AMT [Enabled]

Allows you to enable or disable Intel(R) Active Management Technology BIOS

Extension. The iAMT H/W is always enabled. Configuration options: [Enabled] [Disabled]

3.3.8 PCH-FW Configuration

Firmware Update Configuration

Me FW Image Re-Flash [Disabled]

Enables or disables Me FW Image Re-Flash function. Configuration options: [Enabled] [Disabled]

3.3.9 Power Management

Power Mode [ATX Type]

Select power supply mode. Configuration options: [ATX Type] [AT Type]

Power Saving (ERP) Control [Disabled]

Enables or disables ERP power saving function. Configuration options: [Enabled] [Disabled]

Restore AC Power Loss [Last State]

- [Power Off] The system goes into off state after an AC power loss.
- [Power On] The system goes into on state after an AC power loss.
- [Last State] The system goes into either off or on state, whatever the system state was before the AC power loss.

RTC wake system from S5 [Disabled]

- [Disabled] Disables system wake up from S5.
- [Fixed Time] The system will wake up at the specified hr::min::sec. Configuration options: [Disabled] [Enabled] .
- [Dynamic Time] The system will wake up at the current time plus a specified number of minutes.



The following items appear when **Fixed Time** is enabled.

Wake up day/hour/minute/second [0]

Specify the values for day/hour/minute/second.



The following items appear when **Wake System with Dynamic Time** is enabled.

Wake up minute increase [1]

Specify the number of minutes added to the current time before waking up system.

3.3.10 Digital IO Port Configuration

The items in this menu allow you to modify Digital IO settings.

DIO Port 1~4 [Output]

Set DIO data flow as Input or Output. Configuration options: [Input] [Output]

Output Level [High]

Configuration options: [High][Low]

DIO Port 5~8 [Input]

Set DIO data flow as Input or Output. Configuration options: [Input] [Output]

3.4 Chipset menu

The Chipset menu items allow you to change configuration options for the North Bridge and South Bridge.

3.4.1 System Agent (SA) Configuration

Max TOLUD [Dynamic]

Allows you to select more useable memory on x86 OS. Select [Dynamic] to adjust TOLUD automatically based on the largest MMIO length of the installed graphic controller. Configuration options: [Dynamic] [1 GB] [1.25 GB] [1.5 GB] [1.75GB] [2 GB] [2.25 GB] [2.5GB] [2.75GB] [3 GB] [3.25 GB]

Primary Display [Auto]

Allows you to select the primary display. Configuration options: [Auto] [IGFX] [PEG] [PCIE]

Primary IGFX Boot Display [VBIOS Default]

Select the Video Device to be activated during POST. Your selection does not take effect if you have installed an external graphics device. Secondary boot display selection will appear based on your selection. VGA modes can be supported only on the primary display. Configuration options: [VBIOS Default] [DP1] [eDP [LVDS] [DP2]

LVDS [Enabled]

Allows you to enable or disable LVDS (CH7511). Configuration options: [Disabled] [Enabled]

LVDS Panel Type [1024x768 18bit, 60Hz]

Allows you to configure LVDs panel used by Internal Graphics Device. Configuration options: [640x480, 18bit, 60Hz] [800x480, 18bit, 60Hz] [800x600, 18bit, 60Hz] [1024x600, 18bit, 60Hz] [1024x768, 18bit, 60Hz] [1024x768, 24bit, 60Hz] [1280x768, 24bit, 60Hz] [1280x1024, 48bit, 60Hz] [1366x768, 24bit, 60Hz] [1440x900, 48bit, 60Hz] [1600x1200, 48bit, 60Hz] [1920x1080, 48bit, 60Hz] [1920x1200, 48bit, 60Hz] [1280x800, 24bit, 60Hz] [12800x800, 18bit, 60Hz]

3.5 Security menu

The Security menu items allow you to change the system security settings.

3.5.1 Administrator Password

If you have set an administrator password, we recommend that you enter the administrator password for accessing the system. Otherwise, you might be able to see or change only selected fields in the BIOS setup program.

To set an administrator password:

1. Select the Administrator Password item and press <Enter>.
2. From the Create New Password box, key in a password, then press <Enter>.
3. Confirm the password when prompted.

To change an administrator password:

1. Select the Administrator Password item and press <Enter>.
2. From the Enter Current Password box, key in the current password, then press <Enter>.
3. From the Create New Password box, key in a new password, then press <Enter>.
4. Confirm the password when prompted.

To clear the administrator password, follow the same steps as in changing an administrator password, but press <Enter> when prompted to create/confirm the password. After you clear the password, the Administrator Password item on top of the screen shows Not Installed.

3.5.2 User Password

If you have set a user password, you must enter the user password for accessing the system. The User Password item on top of the screen shows the default Not Installed. After you set a password, this item shows Installed.

To set a user password:

1. Select the User Password item and press <Enter>.
2. From the Create New Password box, key in a password, then press <Enter>.
3. Confirm the password when prompted.

To change a user password:

1. Select the User Password item and press <Enter>.
2. From the Enter Current Password box, key in the current password, then press <Enter>.
3. From the Create New Password box, key in a new password, then press <Enter>.

4. Confirm the password when prompted.

To clear the user password, follow the same steps as in changing a user password, but press <Enter> when prompted to create/confirm the password. After you clear the password, the **User Password** item on top of the screen shows **Not Installed**.

3.6 Boot menu

The Boot menu items allow you to change the system boot options.

Boot Configuration

Quiet Boot [Enabled]

This item enables/disables Quiet Boot. Configuration options: [Disabled] [Enabled]

Launch PXE ROM [Disabled]

This item enables/disables the execution of UEFI and Legacy PXE OpROM. Configuration options: [Disabled] [Enabled]

Boot Option Priorities

These items specify the boot device priority sequence from the available devices. The number of device items that appears on the screen depends on the number of devices installed in the system.



-
- To select the boot device during system startup, press <F7> during POST.
 - To access Windows OS in Safe Mode, do any of the following:
 - Press <F5> during POST.
 - Press <F8> after POST.
-

Boot Override

These items displays the available devices. The number of device items that appears on the screen depends on the number of devices installed in the system. Click an item to start booting from the selected device.

3.7 Save & Exit menu

Save Changes and Reset

Once you are finished making your selections, choose this option from the Save & Exit menu to ensure the values you selected are saved. When you select this option, a confirmation window appears. Select Yes to save changes and reset.

Discard Changes and Reset

This option allows you to exit the Setup program without saving your changes. When you select this option or if you press <Esc>, a confirmation window appears. Select Yes to discard changes and exit.

Save Options

Save or discard changes to current configuration.

Restore Defaults

Save or restore User Defaults to all setup options.

Save as User Defaults

This item saves current configuration as User Default.

Restore User Defaults

This option restores User Defaults to all setup options.

Appendix

Notices

Federal Communications Commission Statement

This device complies with Part 15 of the FCC Rules. Operation is subject to the following two conditions:

- This device may not cause harmful interference.
- This device must accept any interference received including interference that may cause undesired operation.

This equipment has been tested and found to comply with the limits for a Class A digital device, pursuant to Part 15 of the FCC Rules. These limits are designed to provide reasonable protection against harmful interference in a residential installation. This equipment generates, uses and can radiate radio frequency energy and, if not installed and used in accordance with manufacturer's instructions, may cause harmful interference to radio communications. However, there is no guarantee that interference will not occur in a particular installation. If this equipment does cause harmful interference to radio or television reception, which can be determined by turning the equipment off and on, the user is encouraged to try to correct the interference by one or more of the following measures:

- Reorient or relocate the receiving antenna.
- Increase the separation between the equipment and receiver.
- Connect the equipment to an outlet on a circuit different from that to which the receiver is connected.
- Consult the dealer or an experienced radio/TV technician for help.



WARNING! The use of shielded cables for connection of the monitor to the graphics card is required to assure compliance with FCC regulations. Changes or modifications to this unit not expressly approved by the party responsible for compliance could void the user's authority to operate this equipment.



DO NOT throw the motherboard in municipal waste. This product has been designed to enable proper reuse of parts and recycling. This symbol of the crossed out wheeled bin indicates that the product (electrical and electronic equipment) should not be placed in municipal waste. Check local regulations for disposal of electronic products.



DO NOT throw the mercury-containing button cell battery in municipal waste. This symbol of the crossed out wheeled bin indicates that the battery should not be placed in municipal waste.



电子电气产品有害物质限制使用标识要求：图中之数字为产品之环保使用期限。仅指电子电气产品中含有的有害物质不致发生外泄或突变从而对环境造成污染或对人身、财产造成严重损害的期限。

部件名称	有害物质					
	铅 (Pb)	汞 (Hg)	镉 (Cd)	六价铬 (Cr(VI))	多溴联苯 (PBB)	多溴二苯醚 (PBDE)
印刷电路板及其电子组件	×	○	○	○	○	○
外壳	×	○	○	○	○	○
电源适配器	×	○	○	○	○	○
外部信号连接头及线材	×	○	○	○	○	○
中央处理器与内存	×	○	○	○	○	○

本表格依据 SJ/T 11364 的规定编制。

○：表示该有害物质在该部件所有均质材料中的含量均在 GB/T 26572 规定的限量要求以下。

×：表示该有害物质至少在该部件的某一均质材料中的含量超出 GB/T 26572 规定的限量要求，然该部件仍符合欧盟指令 2011/65/EU 的规范。

备注：此产品所标示之环保使用期限，系指在一般正常使用状况下。