

AMB-232A/280A

Close Frame

Industrial LCD Displays

Copyright Notice

This document is copyrighted 2002, by AAEON Technology In. All rights are reserved. The original manufacturer reserves the right to make improvements to the products described in this manual at any time without notice.

No part of this manual may be reproduced, copied, translated, or transmitted in any form or by any means without the prior written permission of the original manufacturer. Information provided in this manual is intended to be accurate and reliable. However, the original manufacturer assumes no responsibility for its use, nor for any infringements upon the rights of third parties, which may result from its use.

The material in this document is for product information only and is subject to change without notice.

Packing List

The LCD monitor comes with the following standard parts shown as below. Check and make sure they are included and in good condition. If anything is missing or damaged, contact the dealer immediately.

1. Industrial Display Panel x 1 pc
2. Industrial Display Panel User's Manual CD-ROM x 1 pc
3. Power adapter x 1 pc
4. VGA Cable 1.8 M x 1 pc
5. Panel Mounting Kits
6. Screws bag
7. Touch Pen x 1 pc (for Penmount Touch Screen models)

It is better for you to keep the carton and the packing materials in case you might need them for packing or moving in the future.

Safety & Warranty

1. Read these safety instructions carefully.
2. Keep this user's manual for later reference.
3. Disconnect this equipment from any AC outlet before cleaning. Do not use liquid or spray detergents for cleaning. Use a damp cloth.
4. For pluggable equipment, the power outlet must be installed near the equipment and must be easily accessible.
5. Keep this equipment away from humidity.
6. Put this equipment on a reliable surface during installation. Dropping it or letting it fall could cause damage.
7. The openings on the enclosure are for air convection. Protect the equipment from overheating. **DO NOT COVER THE OPENINGS.**
8. Make sure the voltage of the power source is correct before connecting the equipment to the power outlet.
9. Position the power cord so that people cannot step on it. Do not place anything over the power cord.
10. All cautions and warnings on the equipment should be noted.
11. If the equipment is not used for a long time, disconnect it from the power source to avoid damage by transient over-voltage.
12. Never pour any liquid into an opening. This could cause fire or electrical shock.
13. Never open the equipment. For safety reasons, only qualified service personnel should open the equipment.
14. If any of the following situations arises, get the equipment checked by service personnel:
 - a. The power cord or plug is damaged.
 - b. Liquid has penetrated into the equipment.
 - c. The equipment has been exposed to moisture.

- d. The equipment does not work well, or you cannot get it to work according to the users manual.
 - e. The equipment has been dropped and damaged.
 - f. The equipment has obvious signs of breakage.
15. DO NOT LEAVE THIS EQUIPMENT IN AN ENVIRONMENT WHERE THE STORAGE TEMPERATURE IS BELOW -20° C (-4°F) OR ABOVE 60° C (140° F). IT MAY DAMAGE THE EQUIPMENT.

Contents

Copyright Notice	1
Packing List	2
Safety & Warranty	3
Chapter 1 General Information	
Introduction.....	7
Features of Display Panels.....	8
Dimension.....	11
Chapter 2 Hardware Installation	
Before Unpacking.....	13
Connecting Power.....	14
Connecting the Computer.....	15
VGA Port Connector.....	16
Serial Ports Connector for Touch	17
Panel Mounting.....	18
Rack Mounting.....	19
Chapter 3 On Screen Display Control	
On Screen Display (OSD) Controller.....	21
Chapter 4 Drivers Installation	
Display Driver Installation.....	30
Touchscreen Driver Installation.....	40
Specifications.....	41
Troubleshooting.....	43

Chapter

1

**General
Information**

Introduction

Congratulations on your purchase of the Industry Display Panel TFT LCD monitor - a marvelous contribution of cutting edge technology.

The LCD monitor has been designed with serious thoughts to present the best performance for most applications. Symbol of elegance, its compact and slim profile is well suited in working locations where space is at a premium.

The TFT LCD monitor displays sharper, more brilliant, crisper and flicker-free images. Complying with the power management regulations of VESA DPMS, the LCD monitor is extremely energy efficient and a power saver. Plus, the LCD monitor has extremely low radiation emissions and near zero electromagnetic fields which are supreme benefits.

Fully compatible with PC system, the LCD monitor provides full interface for all sorts of related standards. Supported by “Plug & Play” complying with DDC1/DDC2B, installing the LCD monitor is absolutely trouble free.

The On Screen Display menu provides user a convenient interface to make right adjustment for optimum display performance.

Features of Display Panels

This menu provides full range of analog interface LCD panels, which are 10.4" (VGA) and 18.1" (SXGA) high-brightness, long lifetime TFT LCD monitors.

- Stainless steel open-frame architecture with aluminum alloy front panel
- 10.4" VGA (800x600 resolution)
18.1" SXGA (1280x1024 resolution) color TFT LCD display
- Analog RGB signals directly input with A/D board interface offering multi-scan function
- RS-232, Adapter, VGA terminals and AV input
- OSD (On Screen Display) function for display adjustment
- Touchscreen (Optional)
- AC-in /DC-out external power adapter
- Swivel ARM: VESA 75/100 Standard
- Auto detect NTSC, PAL and Secam
- Adapter holder

General Specifications

- **Construction:** Stainless steel close frame architecture
- **Mounting:** Panel mount or Swivel ARM
- **Input signal:** RGB, Composite video, S-Video
- **Control:** OSD (On Screen Display) on the front panel
- **Power Supply:** external power adapter
- **Dimension:**
 - AMB-232A:
309(W) x 216(H) x 54.8(D) mm
 - AMB-280A:
482(W) x 398(H) x 57.2(D) mm
- **Net Weight:**
 - AMB-232A: 5.6Kg
 - AMB-280A: 14.5Kg

Touchscreen (Optional)

- **Type:** 8-wire for AMB-232A/ AMB-280A.
 - Analog resistive
- Resolution:**
 - 1024x1024 for AMB-232A
 - 4096x4096 for AMB-280A
- **Light transmission:**
 - 68% or higher
- **Operating pressure:**

Model	AMB-232A	AMB-280A
For Finger (grams)	90	90
Stylus pen (grams)	70	70
Contact bounce (ms)	<10	<10

- **Controller:** RS-232 interface
- **Controller Power consumption:** 8mA@5V, 4MHz
- **OS support** MS DOS, Windows 98, Windows NT, Windows 2000.

Environmental Specifications

- **Operating temperature:** 0°C to 45°C (32~113°F)
- **Storage temperature:** -20°C to 60°C (-4~140°F)
- **Vibration:** 5~150Hz, 1G acceleration.
- **Shock:** 15G peak acceleration (11 msec. Duration)
- **EMI:** FCC / CE Class A

Dimensions

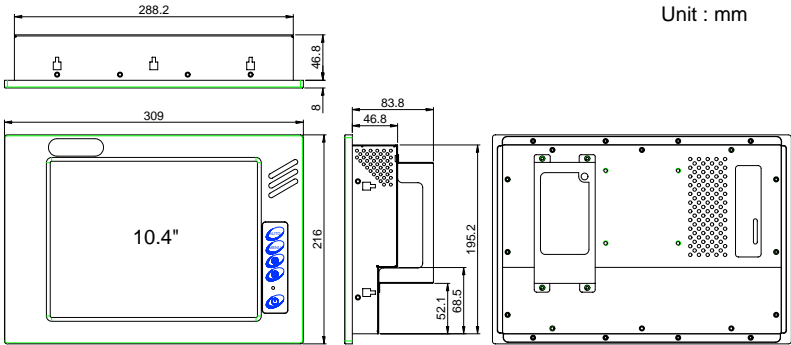

Unit : mm

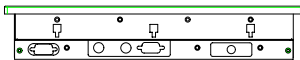

AMB-232A-D
Cutout Size : 291.2 x 198.2 mm

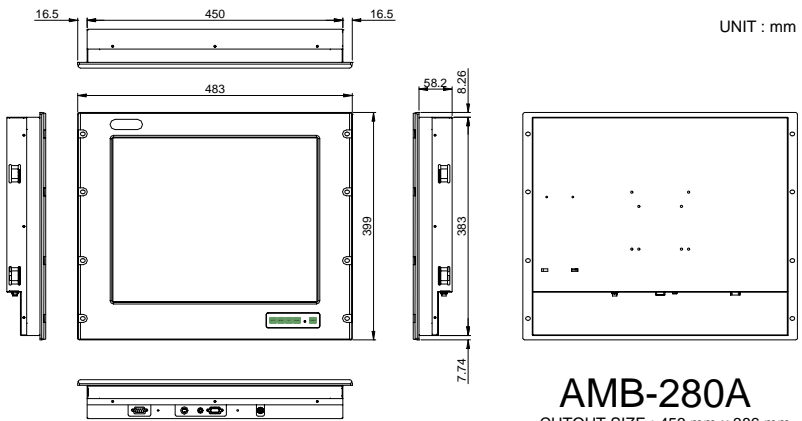

UNIT : mm

AMB-280A
CUTOUT SIZE : 453 mm x 386 mm

Chapter

2

**Hardware
Installation**

Before Unpacking

It is very important to locate the LCD monitor in a suitable environment.

- The surface for placing the LCD monitor should be stable and level.
- Make sure the place has good ventilation, and out of direct sunlight; away from sources of excessive dust, dirt, heat, water, moisture and vibration.
- Convenience for connecting the LCD monitor to the related facilities should be well considered too.

Connecting Power

To power on the LCD monitor, use the provided AC-DC adapter and the power cord to connect to the power output socket of the monitor. Fasten the connections securely.



**The above picture is ONLY to illustrate the power code location and may not contain the right product.

A "Surge Protection" device plugged between the AC-DC adapter and the wall outlet is recommended to prevent the effects of sudden current variations from reaching the LCD monitor. The sudden peaks of electricity may harm the LCD monitor.

Connecting to the Computer

- Turn off the computer and the LCD monitor before connecting them.
- Use the Monitor-to-PC VGA cable to connect the LCD monitor to your computer. The cable heads are the same on either side.
- Fasten the connections securely.

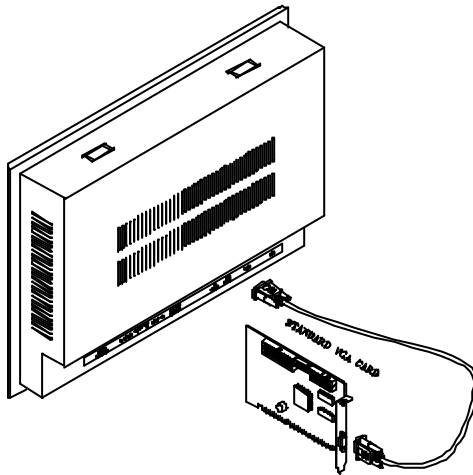

VGA Port Connector

It is a DB-15 VGA connector. The following table shows the pin-out assignments of this connector.

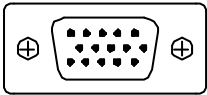

Signal Name	Pin #	Pin #	Signal Name
Red	1	2	Green
Blue	3	4	N.C.
GND	5	6	GND
GND	7	8	GND
N.C.	9	10	GND
N.C.	11	12	SDA
HSYNC	13	14	VSYNC
SCL	15		

Serial Ports Connector for Touch

It is a DB-9 COM Port connector. The following table shows the pin-out assignments of this connector.

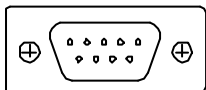

Signal Name	Pin	Pin	Signal Name
Not Used	1	2	RXD, Receive Data
TXD, Transmit Data	3	4	Not Used
GND, Ground	5	8	Not Used
Not Used	4	9	Not Used
Not Used	5	10	Not Used

Panel Mounting

These display panels can be placed on a shelf or table, or mounted onto the wall. To mount them onto the wall, you need the mounting brackets, which you will find in the accessory box. Follow the steps described below:

- Slide the display panel into cutout on the wall.
- Tighten the brackets until the display panel is firmly secured to the wall.

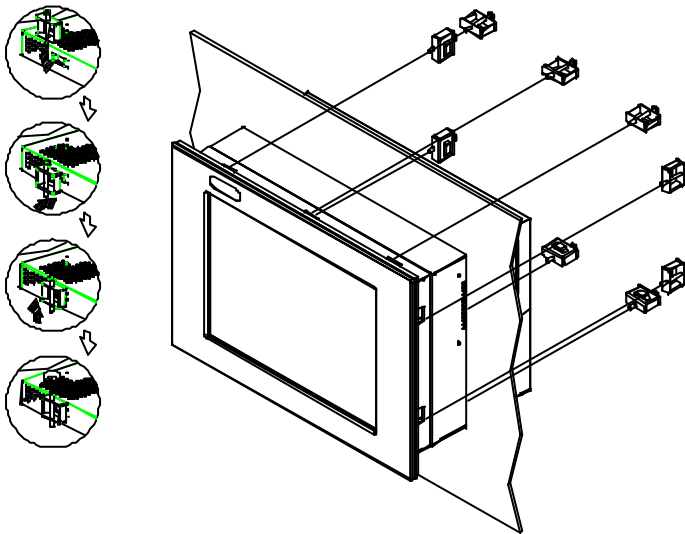

****The above picture is ONLY to illustrate the Panel mounting and may not contain the right product..**

Rack Mounting

Optional 19" rack mount frame is also available for all models.

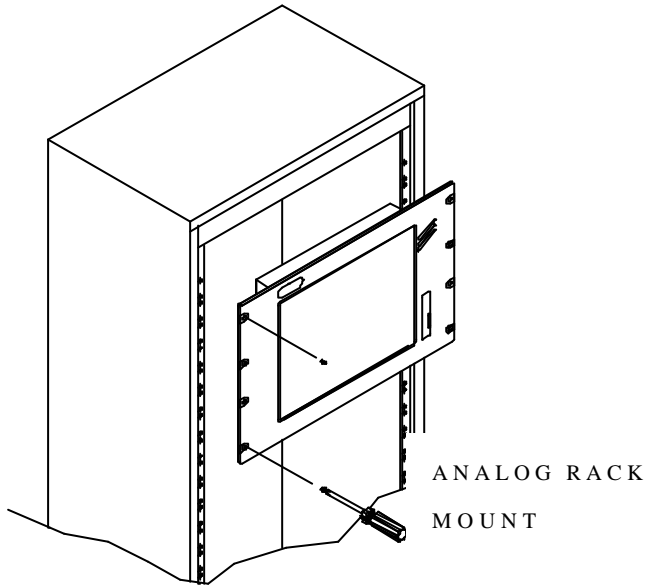

Chapter

3

**On Screen
Display Control**

On Screen Display (OSD) Controller

The LCD monitor is very easy and simple to operate. There are five controls below on the rear panel. You can see their respective indicators.



AMB-232A OSD Controller

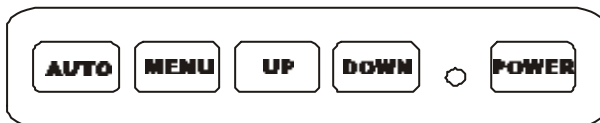

AMB-280A OSD Controller

AUTO

To auto adjust image position, pixel clock and phase. Whenever there is flicker happens, always press the AUTO button first.

The setting value will be automatically

adjusted correctly and saved.

Notice:

The AMB series displays were designed to provide the best quality in 60-75MHz VGA frequency range. We recommend keeping the screen refresh rate within the range in order to obtain the optimum quality.

MENU

Menu

To activate the OSD Menu, press the Button. When locating an item you like to adjust in the OSD Menu, press to bring up the corresponding sub-menu for options.



(UP)



Increase / Moving UP Button

To move the locating cursor forward in the OSD Menu, press UP button. To increase the value while adjusting a parameter, press the  button.



(DOWN)

Decrease / Moving DOWN Button

To move the locating cursor backward in the OSD Menu, press the  button. To decrease the value while adjusting a parameter, press  button.



(POWER)

Power Switch

Push down the Power Switch to turn on/off the LCD monitor backlight and the power LED will light up Green/Red.

Display Menu

There are eight options in the OSD Menu. Press the Menu button to choose the items you would like to adjust.

<Main Menu>

ADB100A AAEON Inc

A screenshot of the main menu displayed on an LCD screen. The menu items are listed vertically in a bold, black font. The items are: InputSource, PIP Enable, AutoTune, Brightness, Contrast, Color, Quality, Position, Language, Recall, Save Exit, and Cancel Exit. The entire menu is enclosed in a double-line black border.

InputSource
PIP Enable
AutoTune
Brightness
Contrast
Color
Quality
Position
Language
Recall
Save Exit
Cancel Exit

<InputSource>

A screenshot of the InputSource menu displayed on an LCD screen. The menu items are listed vertically in a bold, black font. The items are: VGA, AVideo, SVideo, and Return. The entire menu is enclosed in a double-line black border.

VGA
AVideo
SVideo
Return

Select PC or Composite Video Input Source

To scroll through items and locate for adjustment in each page, presses Menu button to select. The display will automatically shut down when there's no input source been selected.

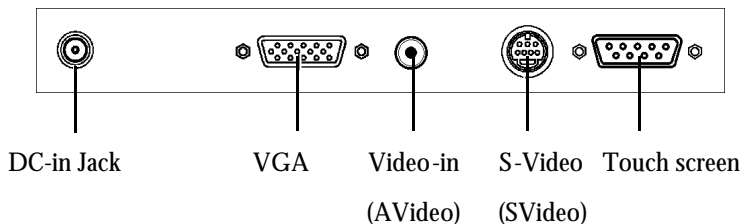
Source input diagram**<PIP enable>**

Picture-in-picture enable function allows you to view screen with VGA input and AVideo or SVideo sources at same time. Use up and down arrows to select major viewing source. Press Menu to enter your selection. The second input source window will be displayed on the bottom right corner.

Combinations are as follows:

VGA (main source) + AVideo (2nd source)

VGA (main source) + SVideo (2nd source)

Press Return to previous menu.

<AutoTune>

To automatically tune the display to the best image size, position and phase.

<Brightness>

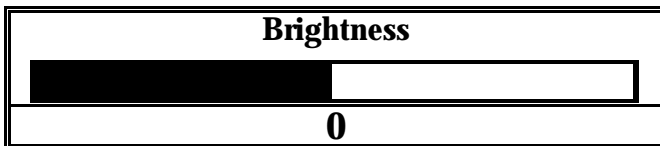

To adjust the brightness level of the image, using up and down arrows button.

<Contrast>

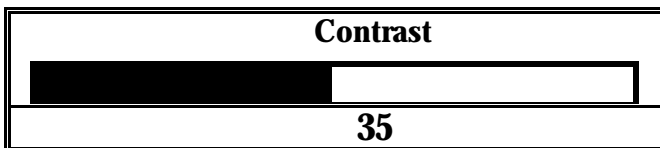

To adjust the difference between the light and dark areas, using up and down arrows button.

<Color>

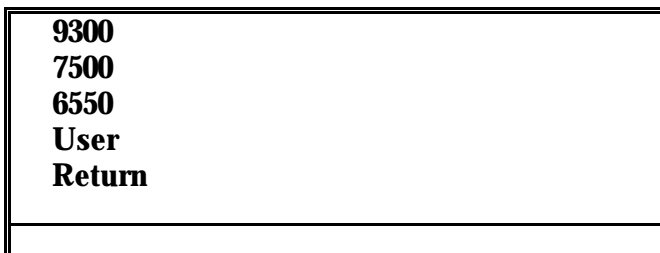

9300: To set the color temperature to 9300K.

7500: To set the color temperature to 7500K.

6550: To set the color temperature to 6550K.

User: To set the RGB color temperature by user defines.

Press Return to previous menu.

<Quality>

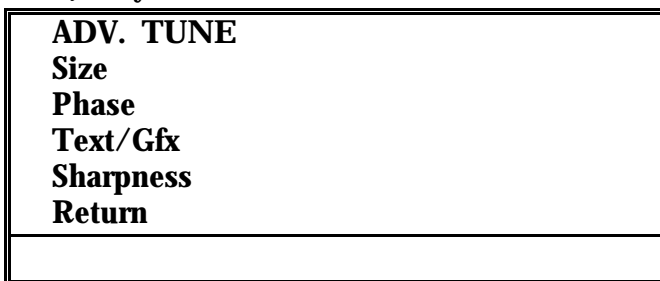

ADV. TUNE: To further tuning the image size, phase, and sharpness. **Please make use of this feature whenever the VGA input has been changed.**

Size: To expand the image of full screen or to shrink the image to normal (1pixel to 1pixel).

Phase: To adjusts the phase of pixel frequency. Use the function when there is a pixel noise.

Text/Gfx: To exchange to the text or graphic mode (Not for Windows OS).

Sharpness: To adjust sharpness of the image.

Press Return to previous menu.

<Position>

Image Pos.: To adjust the Horizontal & Vertical position of the image.

OSD Pos.: To adjust the Horizontal & Vertical position of the OSD Menu.

Speed En. and Speed Adjust: To adjust OSD Menu display speed.

Press Return to previous menu.

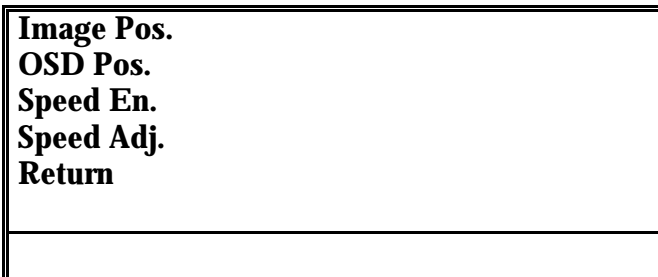
<Language>

Only English is available.

<Recall>

When you run the function, the monitor will be setting to the last status of the saving value.

<Save Exit>

To save all setting value and exit.

<Cancel Exit>

To cancel all setting value and exit.

Hotkey Control

The Hot key control allows you to instant activate frequent use function without browsing OSD menu.



After power on, press the **AUTO** button for 3–5 seconds, The monitor will reset the parameters to default value.

Chapter

4

Drivers Installation

The first time you start Windows with a new monitor, the system will detect OPD display and automatically detect and install the Plug-and-Play device driver.

However, manual installation might be needed when your video card does not comply with DDC1/DDCB2 standard, the system can only detect Windows Default Monitor, not the OPD displays.

When your system detects Windows Default Monitor or cannot detect the display at all, follows the step-by-step installation guide below. The drivers for manual installation are provided in the supporting CD-ROM.

Display Driver Installation

Windows 98

1. Insert the supporting CD-ROM into your CD-ROM Driver.
2. Click “**Start**” button and look for “**Control Panel**” under “**Settings**” menu.

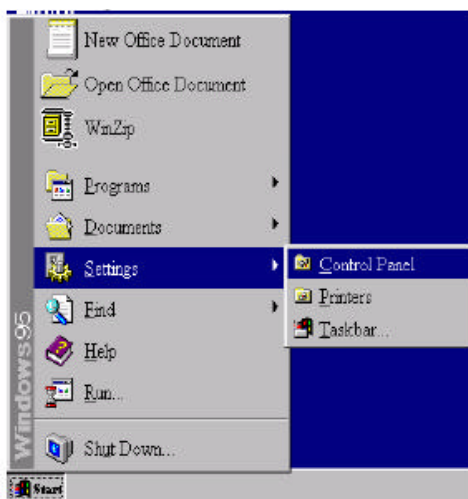

3. Double click the “**display**” icon in the **control panel**.



4. From the “**Display Properties**” window, select the “**settings**” tab. Click the “**Advanced Properties**” button on the bottom right corner.

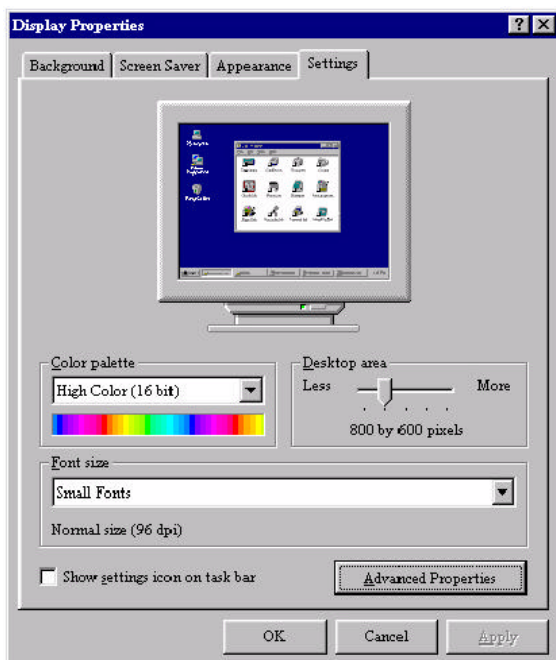

5. Select the “**Monitor**” tab. Click the “**Change**” button in the top right corner.

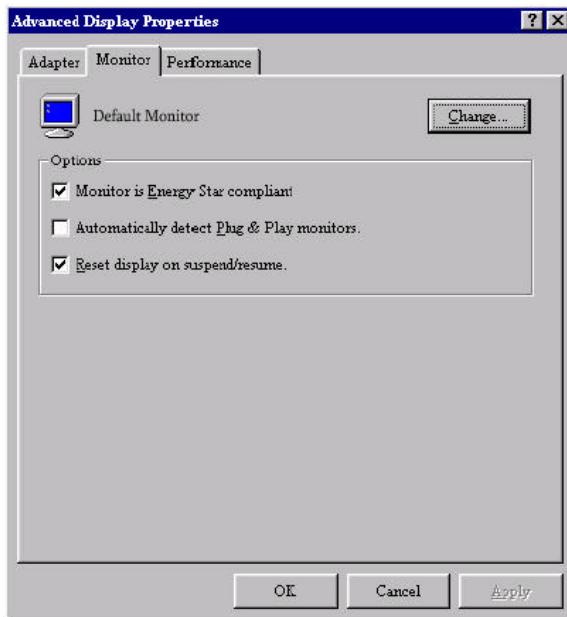

6. Now the “**Update Device Driver Wizard**” opens. Confirm by clicking “**Update**”.

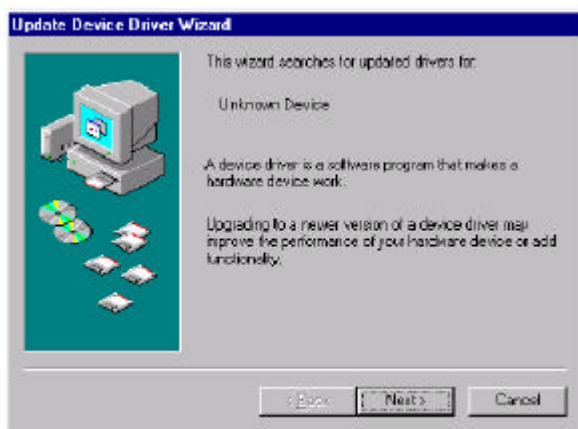

7. Select "**Display a list of all drivers in a specific location, so you can select the driver you want.**" and press "Next".



8. Now click the **“Have disk”** button in the bottom right corner. Another window appears, select the **“Browse”** button. Look for the **“.inf”** file extension for drivers update.

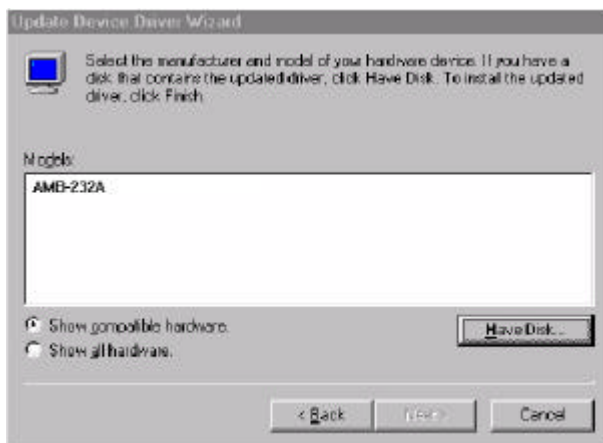

9. Close **“Update Device Driver Wizard”** by click **“Finish”** to complete the installation.

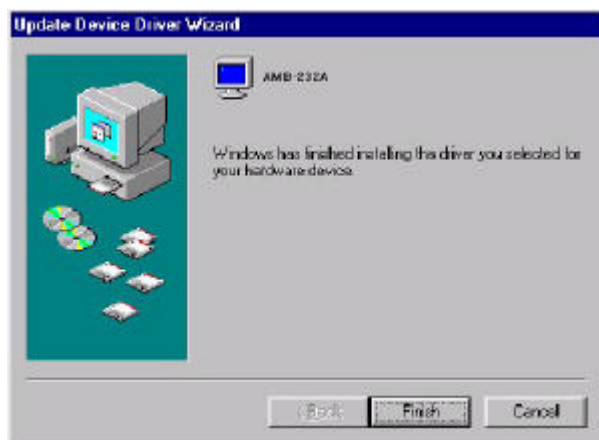

Windows 2000

1. Repeat steps 1 – 4 as in Windows 98 setup.
2. Select the “Monitor” tab. Click the “**Properties**” button.

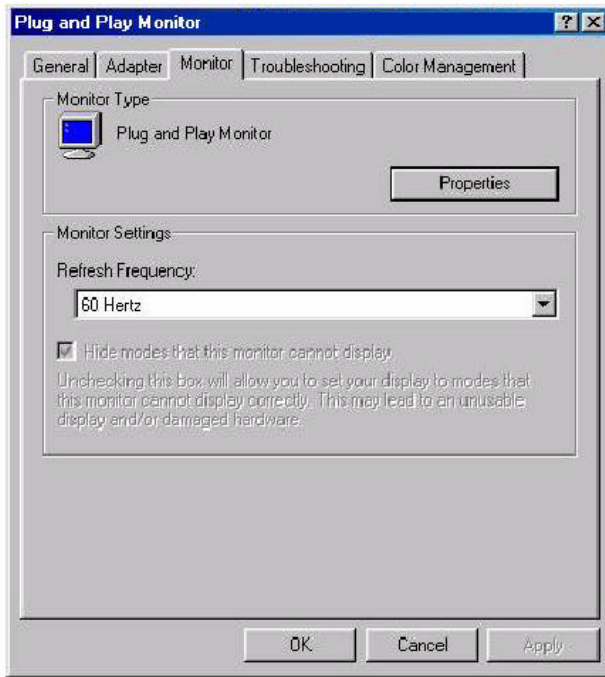

6. Select “**Driver**” tab then click “**Update Driver**”.



7. The “**Upgrade Device Driver Wizard**” will pop up. Then Click “**Next**”.



8. The “**Upgrade Device Driver Wizard**” will pop up. Then Click “**Next**”.

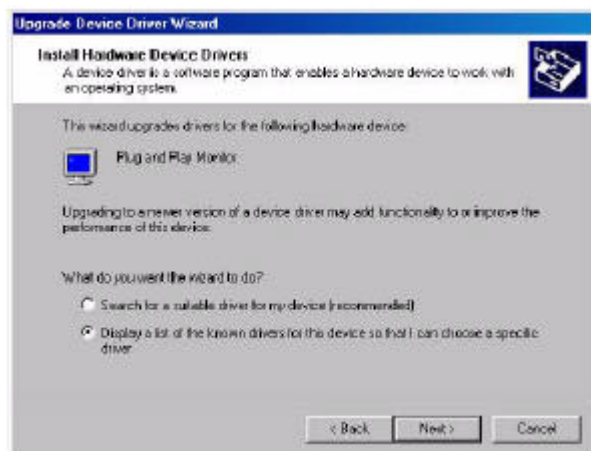

9. In the next window, click “**Have Disk**”, then “**Install From Disk**” window will pop up, click “**Browse**”, the “**Located File**” will pop up. Look for the “.inf” file extension for drivers update

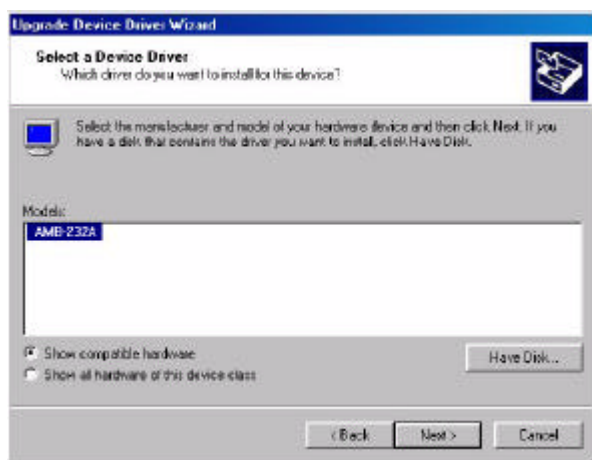

10. In the next window, click “**Have Disk**”, then “**Install From Disk**” window will pop up, click “**Browse**”, the “**Located File**” will pop up. Look for the “.inf” file extension for drivers update.

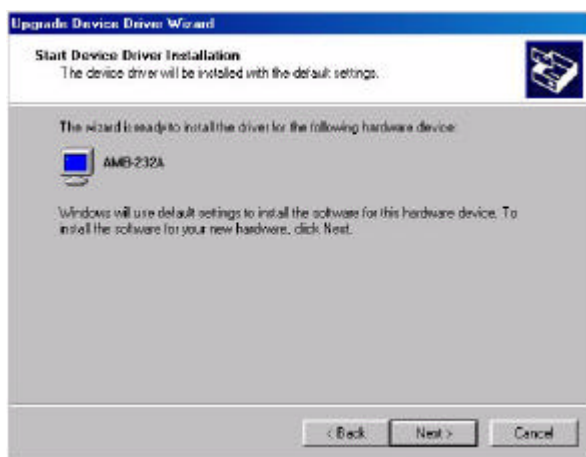

11. The “**Digital Signature Not Found**” window will appear, click
Industrial LCD Display User’s Manual

“Yes”, then click “Finish”.



12. Now the new drivers are installed to your computer.



Touchscreen Driver Installation

For Touchscreen installation please refer to the excel file :
ReadMe_All-Prods-Touch-list.xls to find out your match
touchscreen type and follow the installation guide in respective folders.

Specifications

AMB-232A

Panel	
Type	Color TFT
Size	Diagonal 10.4"
Brightness	250 cd/m ²
Back light MTBF	50,000 hrs
Contrast Ratio	300: 1
Pixel Pitch	0.264(H) x 0.264(V) mm
Viewing Angle (Horizontal)	120°
Viewing Angle (Vertical)	100°
Resolution	800x600
Display Modes	Full Screen in 640x480, 800x600 Mode
Color	262K
Power Consumption	
On- Working	60Watts (Max.)
Input Voltage	AC 100-240V~1.8A, 50~60Hz
Output	DC 12V / 5A(Max)

AMB-280A

Panel	
Type	Color TFT
Size	Diagonal 18.1"
Brightness	250 cd/m ²
Back light Life-time	40,000 hrs
Contrast Ratio	350:1
Pixel Pitch	0.2805(H) x 0.2805(V) mm
Viewing Angle (Horizontal)	160°
Viewing Angle (Vertical)	160°
Resolution	1280x1024
Display Modes	Full Screen in 640x480, 800x600, 1024x768 , 1280x1024 Mode
Color	16M
Power Consumption	
On- Working	60Watts (Max.)
Input Voltage	AC 100-240V~1.8A, 50~60Hz
Output	DC 12V / 5A(Max)

Troubleshooting

To solve the following problems, you may need to refer to **Appendix A Standard Timing** for compatible display specifications.

1. Problem: Unclear or Unsteady Display

Actions:

1. Activate the **AUTO** button. You might need to repeat to find balanced values for a good quality.

If the **AUTO** button cannot solve the problem, try to manual fine tune following steps below:

1. If the image size does not fit the screen, adjust the **Size** setting value under “**Quality**” menu.
2. If there is image pixel noise appears, adjust the **Phase** setting value under “**Quality**” menu. Pull and adjust the value bar to find out what is the best clarity range for your LCD display.
3. If the image is not centered after step 1 and 2, adjust **Image Position** under “**Position**” menu to center the image.
4. If you still have problem to fine-tune the image, call your local technical support for assistance.

2. Problem: No Display is shown on the LCD monitor.

Actions:

1. Make sure the LCD monitor is powered on by checking if the Power LED is lit. Check if all the connections are secure and the system is running correctly.
2. If the power LED lights up green, but there is still nothing displayed; connect your PC with another

external monitor. If your PC works properly with that monitor, then it is possible that the VGA card timing of the system may be outside the LCD monitor's synchronous range. You may need a qualified technician for help.

- 3. Problem: "Not Supported Mode" is shown on the display.**

Action:

This could be a mistake you made in the OSD menu while choosing the INPUT SOURCE: RGB or VEDIO. Or, it is possible that you have chosen a timing that is outside the LCD monitor's synchronous range. Recall the factory default values may help to bring the screen back to normal.

- 4. Problem: The LCD monitor does not work properly under Windows, but it functions all right in DOS mode.**

Action:

Make sure the display mode you choose in Windows matches the LCD monitor.