

# COM-SKUC6 & COM-KBUC6

---

COM Express Module

User's Manual 2<sup>nd</sup> Ed

## Copyright Notice

---

This document is copyrighted, 2019. All rights are reserved. The original manufacturer reserves the right to make improvements to the products described in this manual at any time without notice.

No part of this manual may be reproduced, copied, translated, or transmitted in any form or by any means without the prior written permission of the original manufacturer. Information provided in this manual is intended to be accurate and reliable. However, the original manufacturer assumes no responsibility for its use, or for any infringements upon the rights of third parties that may result from its use.

The material in this document is for product information only and is subject to change without notice. While reasonable efforts have been made in the preparation of this document to assure its accuracy, AAEMON assumes no liabilities resulting from errors or omissions in this document, or from the use of the information contained herein.

AAEMON reserves the right to make changes in the product design without notice to its users.

## Acknowledgement

---

All other products' name or trademarks are properties of their respective owners.

- Microsoft Windows is a registered trademark of Microsoft Corp.
- Intel, Pentium, Celeron, and Xeon are registered trademarks of Intel Corporation
- Core, Atom are trademarks of Intel Corporation
- ITE is a trademark of Integrated Technology Express, Inc.
- IBM, PC/AT, PS/2, and VGA are trademarks of International Business Machines Corporation.

All other product names or trademarks are properties of their respective owners.

## Packing List

---

Before setting up your product, please make sure the following items have been shipped:

Item	Quantity
● COM-SKUC6 or COM-KBUC6	1
● M2.5 screws	4

If any of these items are missing or damaged, please contact your distributor or sales representative immediately.

## About this Document

---

This User's Manual contains all the essential information, such as detailed descriptions and explanations on the product's hardware and software features (if any), its specifications, dimensions, jumper/connector settings/definitions, and driver installation instructions (if any), to facilitate users in setting up their product.

Users may refer to the [AAEON.com](http://AAEON.com) for the latest version of this document.

## Safety Precautions

---

Please read the following safety instructions carefully. It is advised that you keep this manual for future references

1. All cautions and warnings on the device should be noted.
2. Make sure the power source matches the power rating of the device.
3. Position the power cord so that people cannot step on it. Do not place anything over the power cord.
4. Always completely disconnect the power before working on the system's hardware.
5. No connections should be made when the system is powered as a sudden rush of power may damage sensitive electronic components.
6. If the device is not to be used for a long time, disconnect it from the power supply to avoid damage by transient over-voltage.
7. Always disconnect this device from any AC supply before cleaning.
8. While cleaning, use a damp cloth instead of liquid or spray detergents.
9. Make sure the device is installed near a power outlet and is easily accessible.
10. Keep this device away from humidity.
11. Place the device on a solid surface during installation to prevent falls
12. Do not cover the openings on the device to ensure optimal heat dissipation.
13. Watch out for high temperatures when the system is running.
14. Do not touch the heat sink or heat spreader when the system is running
15. Never pour any liquid into the openings. This could cause fire or electric shock.
16. As most electronic components are sensitive to static electrical charge, be sure to ground yourself to prevent static charge when installing the internal components. Use a grounding wrist strap and contain all electronic components in any static-shielded containers.

17. If any of the following situations arises, please the contact our service personnel:
  - i. Damaged power cord or plug
  - ii. Liquid intrusion to the device
  - iii. Exposure to moisture
  - iv. Device is not working as expected or in a manner as described in this manual
  - v. The device is dropped or damaged
  - vi. Any obvious signs of damage displayed on the device
18. **DO NOT LEAVE THIS DEVICE IN AN UNCONTROLLED ENVIRONMENT WITH TEMPERATURES BEYOND THE DEVICE'S PERMITTED STORAGE TEMPERATURES (SEE CHAPTER 1) TO PREVENT DAMAGE.**

## FCC Statement

---

### **Warning!**



This device complies with Part 15 FCC Rules. Operation is subject to the following two conditions: (1) this device may not cause harmful interference, and (2) this device must accept any interference received including interference that may cause undesired operation.

### **Caution:**

*There is a danger of explosion if the battery is incorrectly replaced. Replace only with the same or equivalent type recommended by the manufacturer. Dispose of used batteries according to the manufacturer's instructions and your local government's recycling or disposal directives.*

### **Attention:**

*Il y a un risque d'explosion si la batterie est remplacée de façon incorrecte. Ne la remplacer qu'avec le même modèle ou équivalent recommandé par le constructeur. Recycler les batteries usées en accord avec les instructions du fabricant et les directives gouvernementales de recyclage.*



## China RoHS Requirements (CN)

产品中有毒有害物质或元素名称及含量

AAEON Main Board/ Daughter Board/ Backplane

部件名称	有毒有害物质或元素					
	铅 (Pb)	汞 (Hg)	镉 (Cd)	六价铬 (Cr(VI))	多溴联苯 (PBB)	多溴二苯醚 (PBDE)
印刷电路板 及其电子组件	○	○	○	○	○	○
外部信号 连接器及线材	○	○	○	○	○	○

O: 表示该有毒有害物质在该部件所有均质材料中的含量均在 SJ/T 11363-2006 标准规定的限量要求以下。

X: 表示该有毒有害物质至少在该部件的某一均质材料中的含量超出 SJ/T 11363-2006 标准规定的限量要求。

备注: 此产品所标示之环保使用期限, 系指在一般正常使用状况下。

## China RoHS Requirement (EN)

Poisonous or Hazardous Substances or Elements in Products

AAEON Main Board/ Daughter Board/ Backplane

Component	Poisonous or Hazardous Substances or Elements					
	Lead (Pb)	Mercury (Hg)	Cadmium (Cd)	Hexavalent Chromium (Cr(VI))	Polybrominated Biphenyls (PBB)	Polybrominated Diphenyl Ethers (PBDE)
PCB & Other Components	○	○	○	○	○	○
Wires & Connectors for External Connections	○	○	○	○	○	○
<p>O: The quantity of poisonous or hazardous substances or elements found in each of the component's parts is below the SJ/T 11363-2006-stipulated requirement.</p> <p>X: The quantity of poisonous or hazardous substances or elements found in at least one of the component's parts is beyond the SJ/T 11363-2006-stipulated requirement.</p> <p><b>Note:</b> The Environment Friendly Use Period as labeled on this product is applicable under normal usage only</p>						

# Table of Contents

---

<b>Chapter 1 - Product Specifications .....</b>	<b>1</b>
1.1 Specifications.....	2
<b>Chapter 2 – Hardware Information .....</b>	<b>4</b>
2.1 Dimensions, Jumpers and Connectors .....	5
2.2 List of Jumpers .....	8
2.2.1 AT/ATX Switch & DDI/VGA Switch (SW1) .....	8
2.2.2 ROW A/B Connector (CN1).....	8
2.2.3 ROW C/D Connector (CN2) .....	13
2.2.4 RTC Connector (CN3) .....	17
2.2.5 SPI ROM FLASH (CN4).....	17
<b>Chapter 3 - AMI BIOS Setup .....</b>	<b>18</b>
3.1 System Test and Initialization.....	19
3.2 AMI BIOS Setup.....	20
3.3 Setup submenu: Main .....	21
3.4 Setup submenu: Advanced .....	22
3.4.1 Advanced: CPU Configuration.....	23
3.4.2 Advanced: SATA Configuration.....	24
3.4.3 Advanced: USB Configuration .....	26
3.4.4 Advanced: On-Module FEATURES .....	27
3.4.5 Advanced: SIO Configuration .....	28
3.4.5.1 SIO Configuration: Serial Port 9 Configuration .....	29
3.4.5.2 SIO Configuration: Serial Port 10 Configuration.....	30
3.4.6 Advanced: Power Management.....	31
3.4.7 Advanced: Digital IO Port Configuration.....	32
3.4.8 Advanced: On-Module Hardware Monitor .....	33
3.4.8.1 Fan 1 Mode Configuration: CPU Smart Fan Full Mode .....	34

3.4.8.2	Fan 1 Mode Configuration: CPU Smart Fan Manual Mode	35
3.4.8.3	Fan 1 Mode Configuration: CPU Smart Fan Auto Mode	36
3.4.9	Advanced: Trusted Computing	37
3.4.10	Advanced: Firmware Update Configuration	39
3.5	Setup submenu: Chipset	40
3.5.1	Chipset: System Agent (SA) Configuration	41
3.5.1.1	System Agent (SA): Graphics Configuration	42
3.5.1.2	Graphics Configuration: LVDS Panel Configuration	43
3.5.2	Chipset: PCH-IO Configuration	45
3.5.3	Chipset: PCIE Type Switch Selection	46
3.6	Setup submenu: Security	47
3.6.1	Security: Secure Boot	48
3.6.1.1	Secure Boot: Key Management	49
3.7	Setup submenu: Boot	52
3.7.1	Boot: Hard Drive BBS Priorities	53
3.8	Setup submenu: Save & Exit	54
<b>Chapter 4</b>	<b>Drivers Installation</b>	<b>55</b>
4.1	Driver Download/Installation	56
4.1.1	COM-KBUC6 Driver Installation Steps	56
4.1.2	COM-SKUC6 Driver Installation Steps	58
<b>Appendix A</b>	<b>Watchdog Timer Programming</b>	<b>60</b>
A.1	Watchdog Timer Initial Program	61
<b>Appendix B</b>	<b>I/O Information</b>	<b>66</b>
B.1	I/O Address Map	67
B.2	Memory Address Map	68
B.3	IRQ Mapping Chart	69
<b>Appendix C</b>	<b>Programming Digital I/O</b>	<b>79</b>
C.1	Digital I/O Programming	80

C.2	Digital I/O Register .....	80
C.2	Digital I/O Sample Program .....	81
<b>Appendix D –Notes for Users .....</b>		<b>85</b>
D.1	Notes for Users.....	86

# Chapter 1

---

Product Specifications

## 1.1 Specifications

---

### System

Form Factor	COM Express Compact Size, Type 6
CPU	Onboard 6th/7th Generation Intel® Core™ U-series Processor, BGA type
CPU Frequency	Up to i7-7600U 2C/ 2.8 GHz
Chipset	Onboard 6th/7th Generation Intel® Core™ U-series Processor
Memory Type	DDR3L 1600, SODIMM x 1
Max. Memory Capacity	8 GB
BIOS	AMI BIOS, Legacy Free (Same BIOS for both Skylake and Kabylake)
Wake on LAN	Yes
Watchdog Timer	255 levels
Power Requirement	Standard: +12V
Power Supply Type	AT/ATX Selection
Power Consumption (Typical)	i7-7600U, 8GB DDR3L., full load: 15W 1.32A@12V during 100% loading burn in test
Dimension (L x W)	3.75in x 3.75in (95mm x 95mm)
Operating Temperature	32°F ~ 140°F (0°C ~ 60°C)
Storage Temperature	-40°F ~ 185°F (-40°C ~ 85°C)
Operating Humidity	10% ~90% relative humidity, non-condensing

## System

MTBF (Hours)	182,306 hrs.
Certification	CE/FCC Class A

## Display

VGA/LCD Controller	Onboard 6th Gen Intel® Core™ U-series Processor, GT2-520/510 Onboard 7th Gen Intel® Core™ U-series Processor, GT2-620/610
Video Output	VGA, LVDS/eDP, DDI x 1 (up to 2)

## I/O

Ethernet	Intel® PHY I219LM, Giga LAN (Support Intel® AMT 12.0) x 1
Audio	HD Audio
USB Port	USB 2.0 x 8, USB 3.0 x 4
Serial Port	2-Wire UART (Tx/Rx) x 2
HDD Interface	SATA II x 2; i5, i7 up to 3
Onboard SSD	—
Expansion Slot	PCI-Express Lanes x 8, I2C, LPC, SMBus
GPIO	GPIO 8-bit
TPM	Optional



# Chapter 2

---

Hardware Information

## 2.1 Dimensions, Jumpers and Connectors

### Component Side

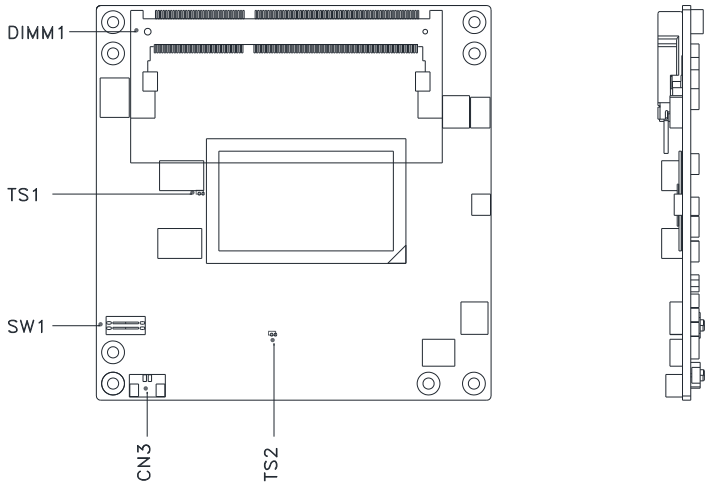
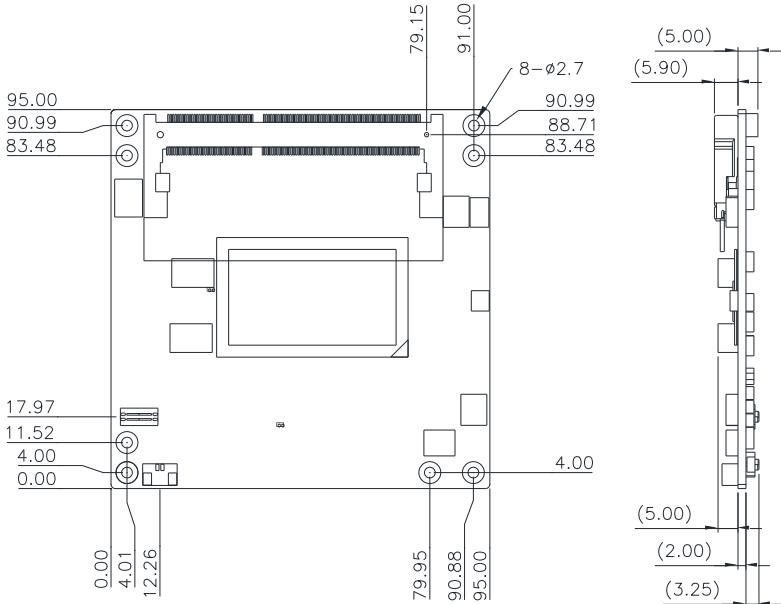

### Solder Side

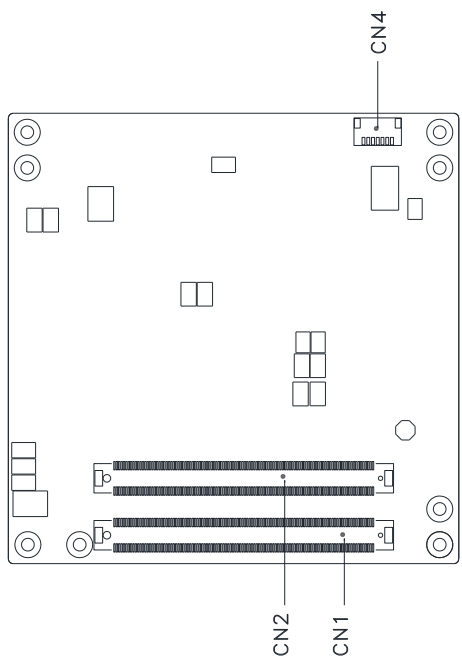
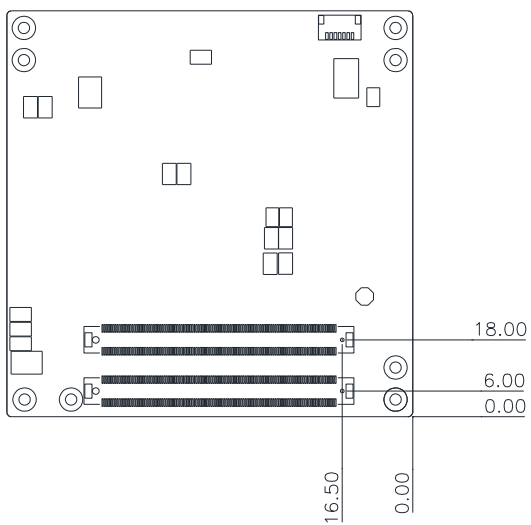

### With Heat spreader

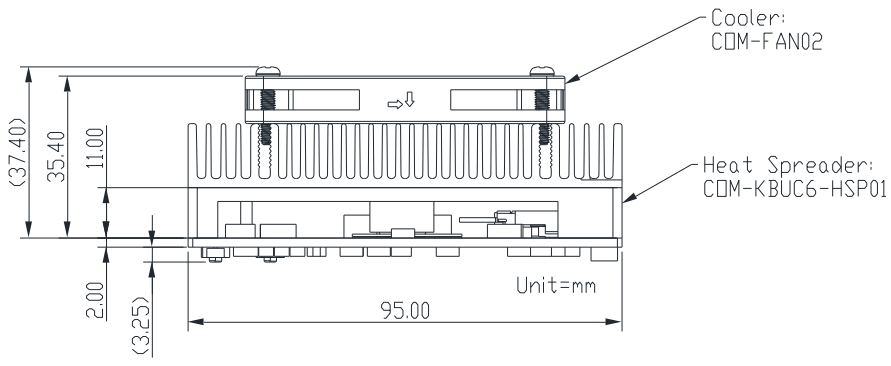

## 2.2 List of Jumpers

Please refer to the table below for all of the board's jumpers that you can configure for your application

Label	Function
SW1	AT/ATX switch & DDI/VGA switch
DIMM1	DDR3L Socket
CN1	ROW A/B
CN2	ROW C/D
CN3	RTC Connector
CN4	SPI ROM FLASH

### 2.2.1 AT/ATX Switch & DDI/VGA Switch (SW1)

	ON	OFF
1	AT Mode	ATX Mode (Default)
2	VGA (Default)	DDI

### 2.2.2 ROW A/B Connector (CN1)

Row A		Row B	
Pin	Signal	Pin	Signal
A1	GND (FIXED)	B1	GND (FIXED)
A2	GBE0_MDI3-	B2	GBE0_ACT#
A3	GBE0_MDI3+	B3	LPC_FRAME#
A4	GBE0_LINK100#	B4	LPC_AD0
A5	GBE0_LINK1000#	B5	LPC_AD1
A6	GBE0_MDI2-	B6	LPC_AD2

Row A		Row B	
Pin	Signal	Pin	Signal
A7	GBE0_MDI2+	B7	LPC_AD3
A8	GBE0_LINK	B8	N.C
A9	GBE0_MDI1-	B9	N.C
A10	GBE0_MDI1+	B10	LPC_CLK
A11	GND (FIXED)	B11	GND (FIXED)
A12	GBE0_MDIO-	B12	PWRBTN#
A13	GBE0_MDIO+	B13	SMB_CK
A14	GBE0_CTREF	B14	SMB_DAT
A15	SUS_S3#	B15	SMB_ALERT#
A16	SATA0_TX+	B16	SATA1_TX+
A17	SATA0_TX-	B17	SATA1_TX-
A18	SUS_S4#	B18	SUS_STAT#
A19	SATA0_RX+	B19	SATA1_RX+
A20	SATA0_RX-	B20	SATA1_RX-
A21	GND (FIXED)	B21	GND (FIXED)
A22	SATA2_TX+ (note)	B22	N.C
A23	SATA2_TX- (note)	B23	N.C
A24	SUS_S5#	B24	PWR_OK
A25	SATA2_RX+ (note)	B25	N.C
A26	SATA2_RX- (note)	B26	N.C
A27	BATLOW#	B27	WDT
A28	ATA_ACT#	B28	N.C
A29	AC_SYNC	B29	AC_SDIN1
A30	AC_RST#	B30	AC_SDIN0
A31	GND (FIXED)	B31	GND (FIXED)
A32	AC_BITCLK	B32	SPKR
A33	AC_SDOOUT	B33	I2C_CK

Row A		Row B	
Pin	Signal	Pin	Signal
A34	BIOS_DIS0#	B34	I2C_DAT
A35	THRMTRIP#	B35	N.C
A36	USB6-	B36	USB7-
A37	USB6+	B37	USB7+
A38	USB_6_7_OC#	B38	USB_4_5_OC#
A39	USB4-	B39	USB5-
A40	USB4+	B40	USB5+
A41	GND (FIXED)	B41	GND (FIXED)
A42	USB2-	B42	USB3-
A43	USB2+	B43	USB3+
A44	USB_2_3_OC#	B44	USB_0_1_OC#
A45	USB0-	B45	USB1-
A46	USB0+	B46	USB1+
A47	VCC_RTC	B47	EXCD1_PERST#
A48	EXCD0_PERST#	B48	EXCD1_CPPE#
A49	EXCD0_CPPE#	B49	SYS_RESET#
A50	LPC_SERIRQ	B50	CB_RESET#
A51	GND (FIXED)	B51	GND (FIXED)
A52	PCIE_TX5+(note)	B52	PCIE_RX5+(note)
A53	PCIE_TX5-(note)	B53	PCIE_RX5-(note)
A54	GPIO	B54	GPO1
A55	PCIE_TX4+(note)	B55	PCIE_RX4+(note)
A56	PCIE_TX4-(note)	B56	PCIE_RX4-(note)
A57	GND	B57	GPO2
A58	PCIE_TX3+(note)	B58	PCIE_RX3+(note)
A59	PCIE_TX3-(note)	B59	PCIE_RX3-(note)
A60	GND (FIXED)	B60	GND (FIXED)

Row A		Row B	
Pin	Signal	Pin	Signal
A61	PCIE_TX2+	B61	PCIE_RX2+
A62	PCIE_TX2-	B62	PCIE_RX2-
A63	GPI1	B63	GPO3
A64	PCIE_TX1+	B64	PCIE_RX1+
A65	PCIE_TX1-	B65	PCIE_RX1-
A66	GND	B66	WAKE0#
A67	GPI2	B67	WAKE1#
A68	PCIE_TX0+	B68	PCIE_RX0+
A69	PCIE_TX0-	B69	PCIE_RX0-
A70	GND (FIXED)	B70	GND (FIXED)
A71	LVDS_A0+	B71	LVDS_B0+
A72	LVDS_A0-	B72	LVDS_B0-
A73	LVDS_A1+	B73	LVDS_B1+
A74	LVDS_A1-	B74	LVDS_B1-
A75	LVDS_A2+	B75	LVDS_B2+
A76	LVDS_A2-	B76	LVDS_B2-
A77	LVDS_VDD_EN	B77	LVDS_B3+
A78	LVDS_A3+	B78	LVDS_B3-
A79	LVDS_A3-	B79	LVDS_BKLT_EN
A80	GND (FIXED)	B80	GND (FIXED)
A81	LVDS_A_CK+	B81	LVDS_B_CK+
A82	LVDS_A_CK-	B82	LVDS_B_CK-
A83	LVDS_I2C_CK	B83	LVDS_BKLT_CTRL
A84	LVDS_I2C_DAT	B84	VCC_5V_SBY
A85	GPI3	B85	VCC_5V_SBY
A86	KBRST#(option)	B86	VCC_5V_SBY
A87	H_A20GATE(option)	B87	VCC_5V_SBY



Row A		Row B	
Pin	Signal	Pin	Signal
A88	PCIE0_CK_REF+	B88	BISO_DIS1#
A89	PCIE0_CK_REF-	B89	VGA_RED
A90	GND (FIXED)	B90	GND (FIXED)
A91	+V3.3S(option)	B91	VGA_GRN
A92	SPI_MISO	B92	VGA_BLU
A93	GPO0	B93	VGA_HSYNC
A94	SPI_CLK	B94	VGA_VSYNC
A95	SPI_MOSI	B95	VGA_I2C_CK
A96	GND	B96	VGA_I2C_DAT
A97	N.C	B97	SPI_CS#
A98	CB_STXD1X	B98	SMI#
A99	CB_SRXD1X	B99	SCI#
A100	GND (FIXED)	B100	GND (FIXED)
A101	CB_STXD2X	B101	CB_FAN_PWM
A102	CB_SRXD2X	B102	CB_FAN_TACH
A103	PCH_LID#	B103	PCH_SLEEP#
A104	VCC_12V	B104	VCC_12V
A105	VCC_12V	B105	VCC_12V
A106	VCC_12V	B106	VCC_12V
A107	VCC_12V	B107	VCC_12V
A108	VCC_12V	B108	VCC_12V
A109	VCC_12V	B109	VCC_12V
A110	GND (FIXED)	B110	GND (FIXED)

\*Note : Custom BIOS require to active this pin. This function for i5/i7 sku CPU only.

## 2.2.3 ROW C/D Connector (CN2)

Row C		Row D	
Pin	Signal	Pin	Signal
C1	GND (FIXED)	D1	GND (FIXED)
C2	GND (FIXED)	D2	GND (FIXED)
C3	USB_SSRX0-	D3	USB_SSTX0-
C4	USB_SSRX0+	D4	USB_SSTX0+
C5	GND (FIXED)	D5	GND (FIXED)
C6	USB_SSRX1-	D6	USB_SSTX1-
C7	USB_SSRX1+	D7	USB_SSTX1+
C8	GND (FIXED)	D8	GND (FIXED)
C9	USB_SSRX2-	D9	USB_SSTX2-
C10	USB_SSRX2+	D10	USB_SSTX2+
C11	GND (FIXED)	D11	GND (FIXED)
C12	USB_SSRX3-	D12	USB_SSTX3-
C13	USB_SSRX3+	D13	USB_SSTX3+
C14	GND (FIXED)	D14	GND (FIXED)
C15	N.C	D15	DDI1_CTRLCLK_AUX+
C16	N.C	D16	DDI1_CTRLDATA_AUX-
C17	RSVD	D17	RSVD
C18	RSVD	D18	RSVD
C19	PCIE_RX6+(note)	D19	PCIE_TX6+(note)
C20	PCIE_RX6-(note)	D20	PCIE_TX6-(note)
C21	GND (FIXED)	D21	GND (FIXED)
C22	PCIE_RX7+(note)	D22	PCIE_TX7+(note)
C23	PCIE_RX7-(note)	D23	PCIE_TX7-(note)
C24	DDI1_HPD	D24	RSVD

C25	N.C	D25	RSVD
C26	N.C	D26	DDI1_PAIR0+
C27	RSVD	D27	DDI1_PAIR0-
C28	RSVD	D28	RSVD
C29	N.C	D29	DDI1_PAIR1+
C30	N.C	D30	DDI1_PAIR1-
C31	GND (FIXED)	D31	GND (FIXED)
C32	DDI2_CTRLCLK_AUX+	D32	DDI1_PAIR2+
C33	DDI2_CTRLDATA_AUX-	D33	DDI1_PAIR2-
C34	DDI2_DDC_AUX_SEL	D34	DDI1_DDC_AUX_SEL
C35	RSVD	D35	RSVD
C36	N.C	D36	DDI1_PAIR3+
C37	N.C	D37	DDI1_PAIR3-
C38	N.C	D38	RSVD
C39	N.C	D39	DDI2_PAIR0+
C40	N.C	D40	DDI2_PAIR0-
C41	GND (FIXED)	D41	GND (FIXED)
C42	N.C	D42	DDI2_PAIR1+
C43	N.C	D43	DDI2_PAIR1-
C44	N.C	D44	DDI1_HPDP
C45	RSVD	D45	RSVD
C46	N.C	D46	DDI2_PAIR2+
C47	N.C	D47	DDI2_PAIR2-
C48	RSVD	D48	RSVD
C49	N.C	D49	DDI2_PAIR3+
C50	N.C	D50	DDI2_PAIR3-
C51	GND (FIXED)	D51	GND (FIXED)
C52	N.C	D52	N.C
C53	N.C	D53	N.C

C54	N.C	D54	N.C
C55	N.C	D55	N.C
C56	N.C	D56	N.C
C57	N.C	D57	GND
C58	N.C	D58	N.C
C59	N.C	D59	N.C
C60	GND (FIXED)	D60	GND (FIXED)
C61	N.C	D61	N.C
C62	N.C	D62	N.C
C63	RSVD	D63	RSVD
C64	RSVD	D64	RSVD
C65	N.C	D65	N.C
C66	N.C	D66	N.C
C67	RSVD	D67	GND (FIXED)
C68	N.C	D68	N.C
C69	N.C	D69	N.C
C70	GND (FIXED)	D70	GND (FIXED)
C71	N.C	D71	N.C
C72	N.C	D72	N.C
C73	GND (FIXED)	D73	GND (FIXED)
C74	N.C	D74	N.C
C75	N.C	D75	N.C
C76	GND (FIXED)	D76	GND (FIXED)
C77	RSVD	D77	RSVD
C78	N.C	D78	N.C
C79	N.C	D79	N.C
C80	GND (FIXED)	D80	GND (FIXED)
C81	N.C	D81	N.C
C82	N.C	D82	N.C

C83	RSVD	D83	RSVD
C84	GND (FIXED)	D84	GND (FIXED)
C85	N.C	D85	N.C
C86	N.C	D86	N.C
C87	GND (FIXED)	D87	GND (FIXED)
C88	N.C	D88	N.C
C89	N.C	D89	N.C
C90	GND (FIXED)	D90	GND (FIXED)
C91	N.C	D91	N.C
C92	N.C	D92	N.C
C93	GND	D93	GND
C94	N.C	D94	N.C
C95	N.C	D95	N.C
C96	GND (FIXED)	D96	GND (FIXED)
C97	RSVD	D97	RSVD
C98	N.C	D98	N.C
C99	N.C	D99	N.C
C100	GND (FIXED)	D100	GND (FIXED)
C101	N.C	D101	N.C
C102	N.C	D102	N.C
C103	GND (FIXED)	D103	GND
C104	VCC_12V	D104	VCC_12V
C105	VCC_12V	D105	VCC_12V
C106	VCC_12V	D106	VCC_12V
C107	VCC_12V	D107	VCC_12V
C108	VCC_12V	D108	VCC_12V
C109	VCC_12V	D109	VCC_12V
C110	GND (FIXED)	D110	GND (FIXED)

\*Note : Custom BIOS require to active this pin. This function for i5/i7 sku CPU only.

## 2.2.4 RTC Connector (CN3)

---

Pin	Signal
1	Battery power
2	GND

## 2.2.5 SPI ROM FLASH (CN4)

---

Pin	Signal
1	SPI_SO_F
2	GND
3	SPI_CLK_F
4	3.3V
5	SPI_SI_F
6	SPI_CE0#_F
7	SPI_CE1#_F

# Chapter 3

---

AMI BIOS Setup

## 3.1 System Test and Initialization

---

The board uses certain routines to test and initialize board hardware. If the routines encounter an error during the tests, you will either hear a few short beeps or see an error message on the screen. There are two kinds of errors: fatal and non-fatal. The system can usually continue the boot up sequence with non-fatal errors.

System configuration verification routines check the current system configuration stored in the CMOS memory and BIOS NVRAM. If a system configuration is not found or a system configuration data error is detected, the system will load the optimized default and re-boot with this default system configuration automatically.

There are four situations in which you will need to setup system configuration:

- You are starting your system for the first time.
- You have changed the hardware attached to your system.
- The system configuration is reset by Clear-CMOS jumper.
- The CMOS memory has lost power and the configuration information has been erased.

The COM-KBUC6-A11 CMOS memory has an integral lithium battery backup for data retention. You will need to replace the complete unit when it runs down.



## 3.2 AMI BIOS Setup

---

The AMI BIOS ROM has a built-in Setup program that allows users to modify the basic system configuration. This information is stored in the battery-backed CMOS RAM and BIOS NVRAM so it retains the Setup information when the power is turned off.

To enter Setup, power on the computer and press <Del> or <ESC> immediately.

The function of each interface is as follows:

**Main** – Date and time can be set here. Use <Tab> to switch between date elements.

**Advanced** – Enable/disable boot option for legacy network devices.

**Chipset** – Host bridge parameters.

**Security** – Password for setup administrator can be set here.

**Boot** – Enable/disable Quiet Boot Option.

**Save & Exit** – Save changes and exit Setup.

### 3.3 Setup submenu: Main



### 3.4 Setup submenu: Advanced

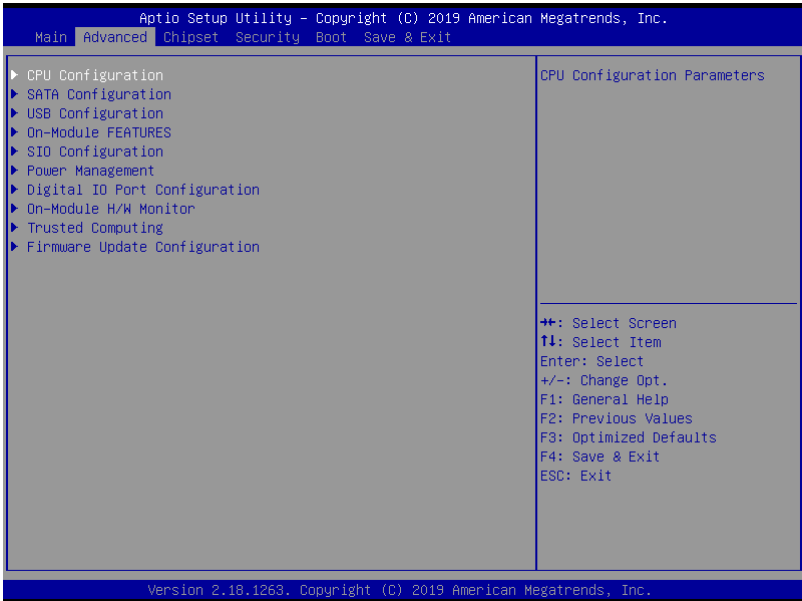

### 3.4.1 Advanced: CPU Configuration



Options Summary		
Hyper-Threading	Disabled	
	Enabled	Optimal Default, Failsafe Default
Enabled for Windows XP and Linux (OS optimized for Hyper-Threading Technology) and Disabled for other OS (OS not optimized for Hyper-Threading Technology).		
Intel (VMX) Virtualization Technology	Disabled	
	Enabled	Optimal Default, Failsafe Default
When enabled, a VMM can utilize the additional hardware capabilities provided by Vanderpool Technology.		
Intel® Speed Shift Technology	Disabled	
	Enabled	Optimal Default, Failsafe Default
Enable/D isable Intel® Speed Shift Technology support. Enabling will expose the CPPC v2 interface to allow for hardware controlled P-states.		
Intel® SpeedStep™	Disabled	
	Enabled	Optimal Default, Failsafe Default
Allows more than two frequency ranges to be supported.		

### 3.4.2 Advanced: SATA Configuration

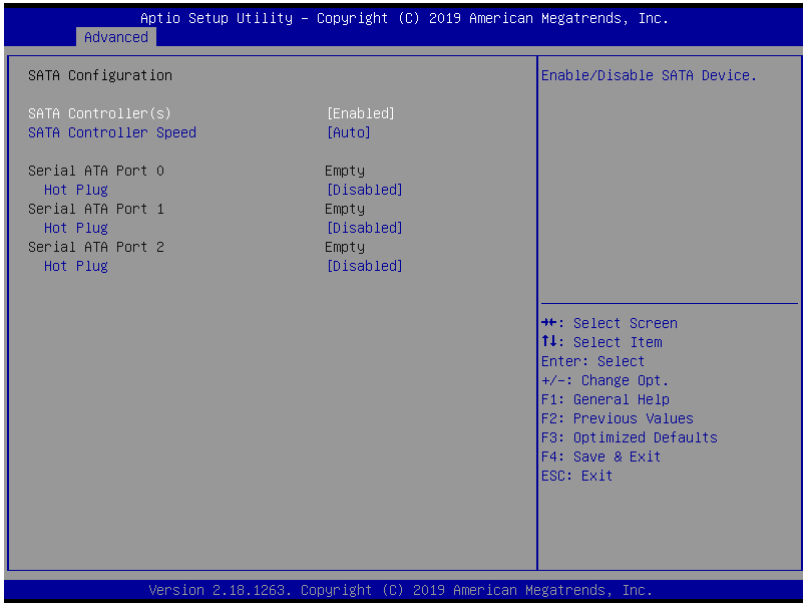

Options Summary		
SATA Controller(s)	Enabled	Optimal Default, Failsafe Default
	Disabled	
Enable/Disable SATA Device.		
SATA Controller Speed	Auto	Optimal Default, Failsafe Default
	Gen1	
	Gen2	
	Gen3	
Indicates the maximum speed the SATA controller can support.		
Port 0	Disabled	
	Enabled	Optimal Default, Failsafe Default
Enable or Disable SATA Port.		
Hot Plug	Disabled	Optimal Default, Failsafe Default
	Enabled	
Designates this port as Hot Pluggable.		

Options Summary		
<b>Port 1</b>	Disabled	
	Enabled	Optimal Default, Failsafe Default
Enable or Disable SATA Port.		
<b>Hot Plug</b>	Disabled	Optimal Default, Failsafe Default
	Enabled	
Designates this port as Hot Pluggable.		
<b>Port 2</b>	Disabled	
	Enabled	Optimal Default, Failsafe Default
Enable or Disable SATA Port.		
<b>Hot Plug</b>	Disabled	Optimal Default, Failsafe Default
	Enabled	
Designates this port as Hot Pluggable.		

### 3.4.3 Advanced: USB Configuration

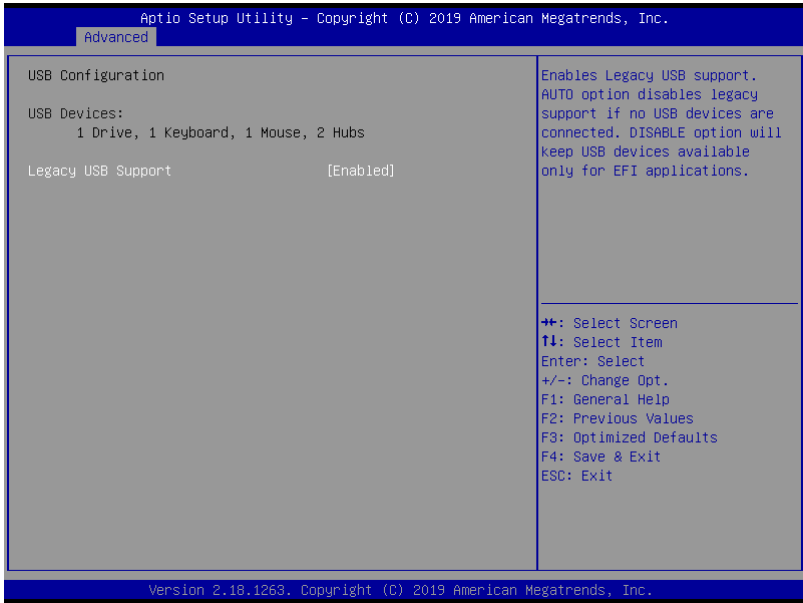

Options summary:

Options Summary		
Legacy USB Support	Enabled	Optimal Default, Failsafe Default
	Disabled	
	Auto	
Enables Legacy USB support. AUTO option disables legacy support if no USB devices are connected. Disable option will keep USB devices available only for EFI application.		

### 3.4.4 Advanced: On-Module FEATURES

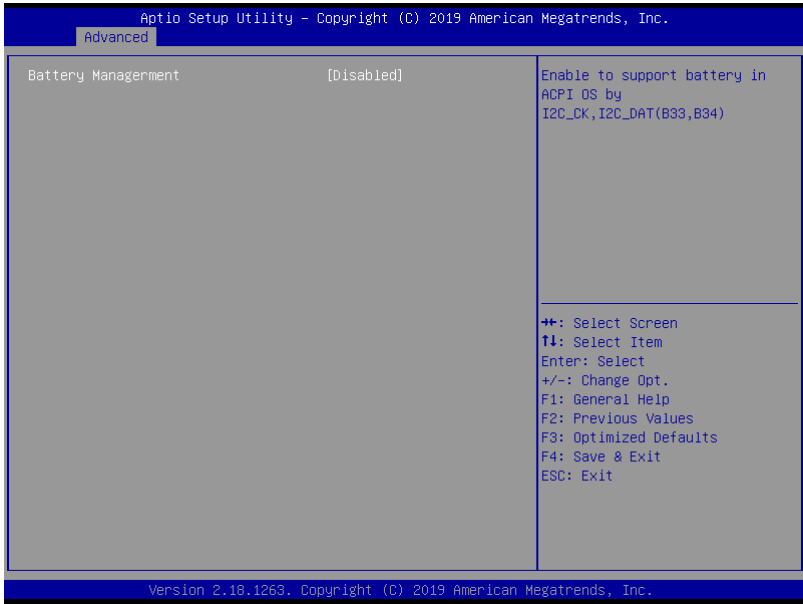

Options Summary		
Battery	Disabled	Optimal Default, Failsafe Default
Management	One Battery	
Enabled to support battery in ACPI OS by I2C_CK , I2C_DAT (B33,B34)		



### 3.4.5 Advanced: SIO Configuration

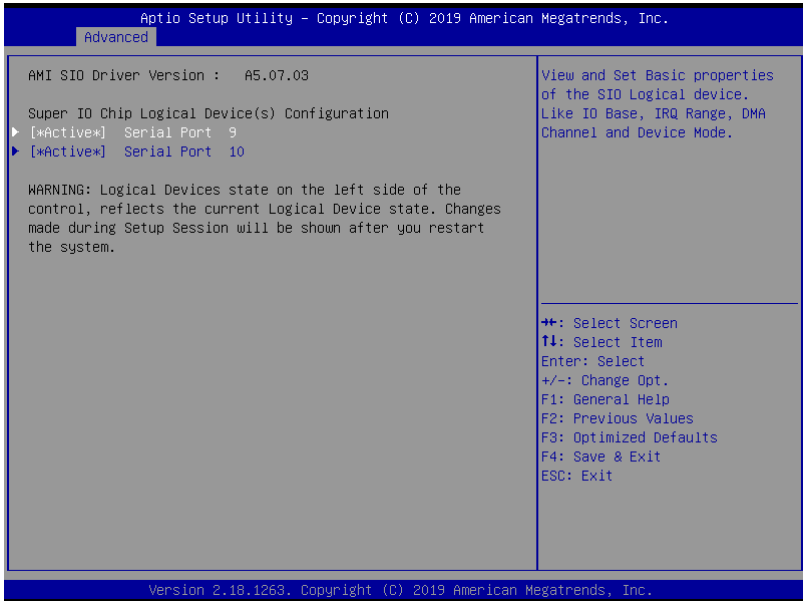

### 3.4.5.1 SIO Configuration: Serial Port 9 Configuration

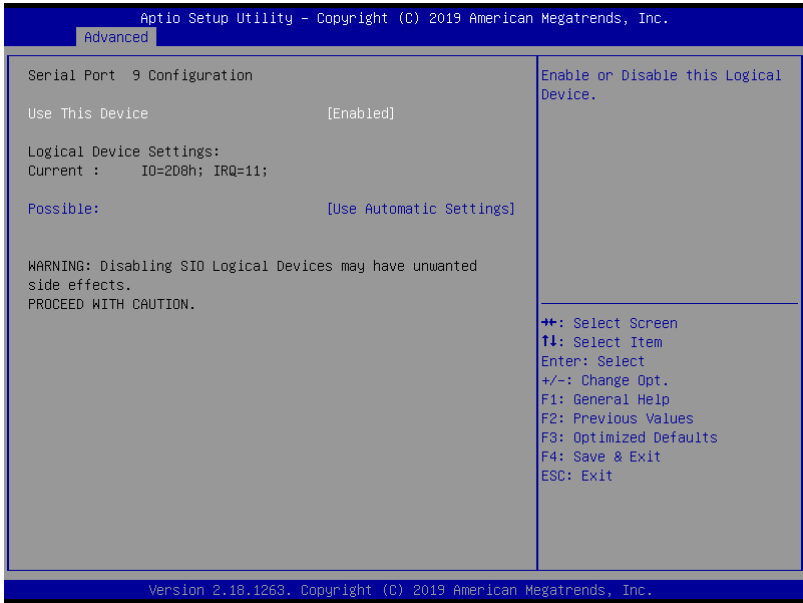

Options Summary		
Use This Device	Disabled	
	Enabled	Optimal Default, Failsafe Default
Enabled or Disabled this Logical Device.		
Possible:	Use Automatic Settings	Optimal Default, Failsafe Default
	IO=2D8h; IRQ=11; DMA;	
	IO=2C8h; IRQ=11; DMA;	
Allows the user to change the device resource settings. New settings will be reflected on this setup page after system restarts.		

### 3.4.5.2 SIO Configuration: Serial Port 10 Configuration

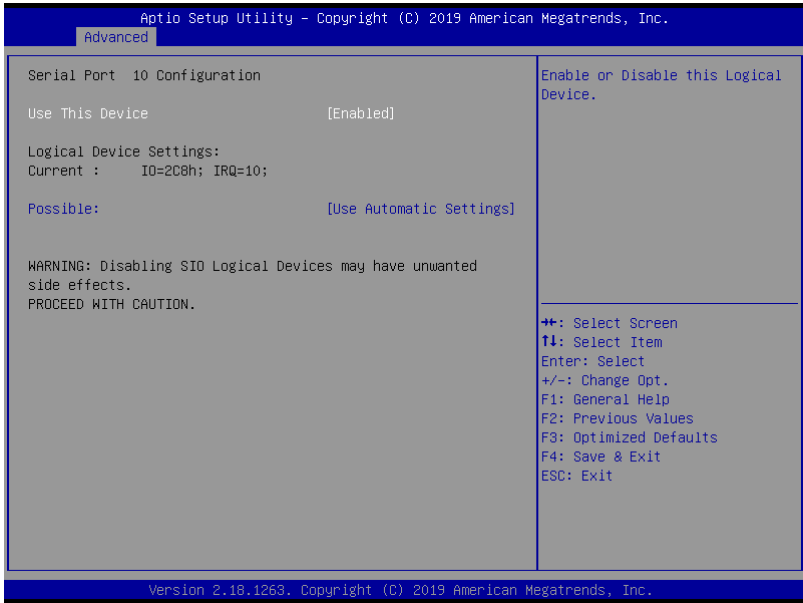

Options Summary		
Use This Device	Disabled	
	Enabled	Optimal Default, Failsafe Default
Enabled or Disabled this Logical Device.		
Possible:	Use Automatic Settings	Optimal Default, Failsafe Default
	IO=2C8h; IRQ=10; DMA;	
	IO=2D8h; IRQ=10; DMA;	
Allows the user to change the device resource settings. New settings will be reflected on this setup page after system restarts.		

### 3.4.6 Advanced: Power Management

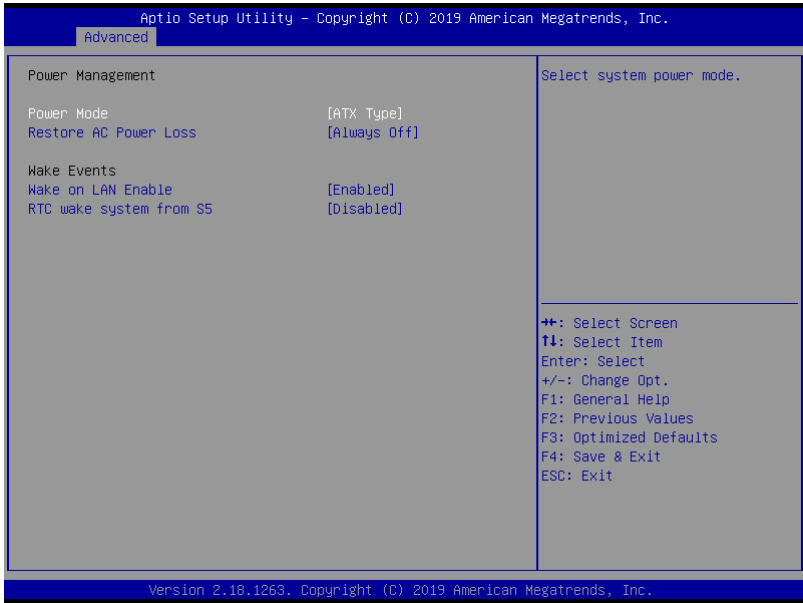

Options Summary		
Power Mode	ATX Type	Optimal Default, Failsafe Default
	AT Type	
Select system power mode.		
Restore AC Power Loss	Last State	
	Always On	
	Always Off	Optimal Default, Failsafe Default
Wake on LAN Enable	Enabled	Optimal Default, Failsafe Default
	Disabled	
Enabled/ Disabled integrated LAN to wake the system.		
RTC wake system from S5	Disabled	Optimal Default, Failsafe Default
	Fixed Time	
Fixed Time: System will wake on the hr::min::sec specified.		
Dynamice time: System will wake on the current time + Increase minute(s)		

### 3.4.7 Advanced: Digital IO Port Configuration

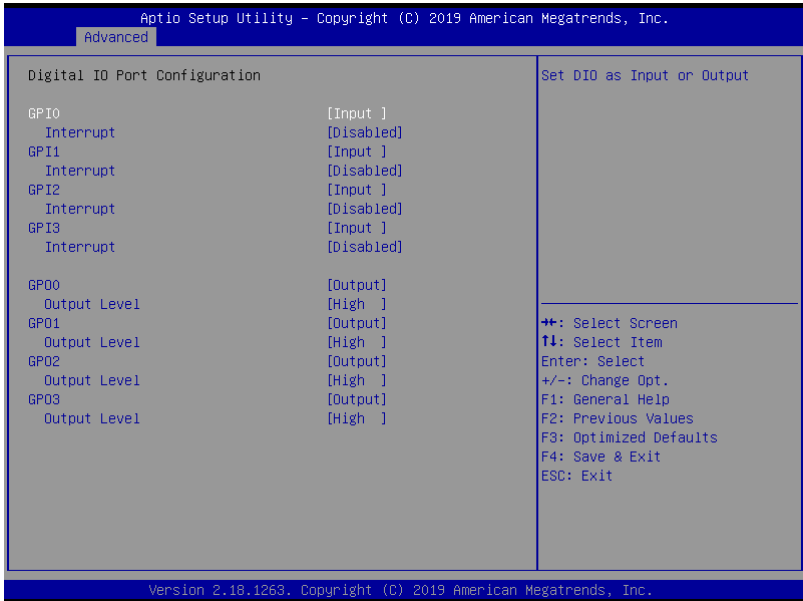

Options Summary		
GPI *	Input	Optimal Default, Failsafe Default
	Output	
Set DIO as Input or Output		
Interrupt	Disabled	Optimal Default, Failsafe Default
	Enabled	
Enabled interrupt function with low pulse mode. This triggered pulse needs more then the 10ms.		
GPO *	Input	
	Output	Optimal Default, Failsafe Default
Set DIO as Input or Output		
Output Level	High	Optimal Default, Failsafe Default
	Low	
Set output level when DIO pin is output		

### 3.4.8 Advanced: On-Module Hardware Monitor

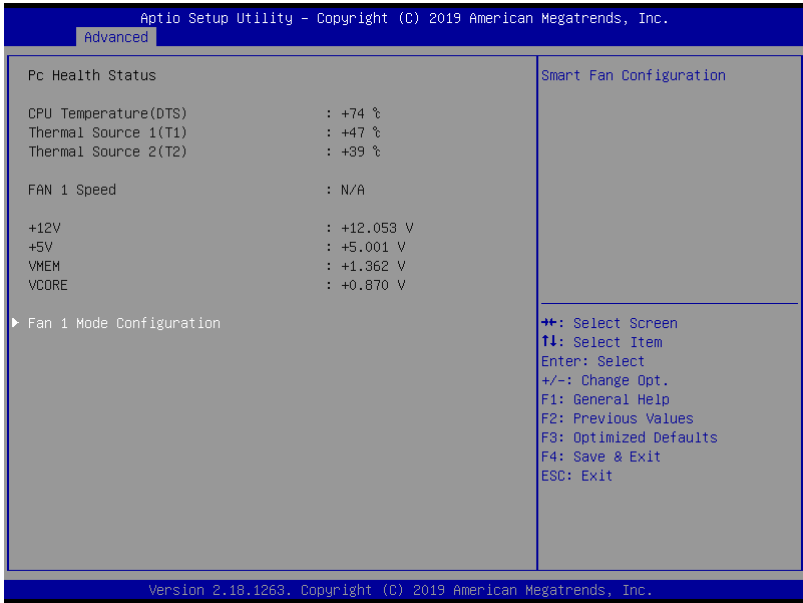

### 3.4.8.1 Fan 1 Mode Configuration: CPU Smart Fan Full Mode

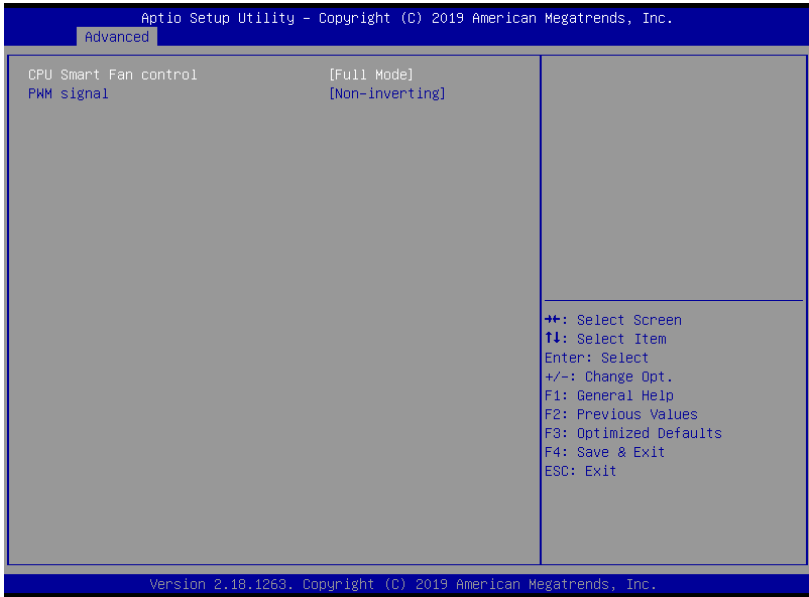

Options Summary		
CPU Smart Fan control	Full Mode	Optimal Default, Failsafe Default
	Manual Mode by PWM	
	Auto Mode by PWM	
PWM signal	Non-inverting	Optimal Default, Failsafe Default
	Inverting	
Select output PWM of inverting or non-uninverting signal		

### 3.4.8.2 Fan 1 Mode Configuration: CPU Smart Fan Manual Mode

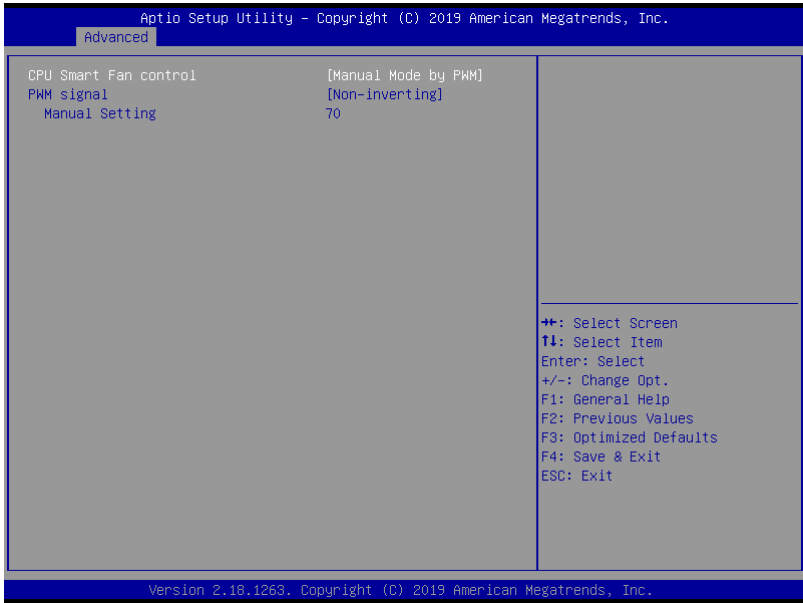

Options Summary		
Manual Setting	70	Optimal Default, Failsafe Default
Set Fan at fixed Duty-Cycle Min=0 Max=100 Please input Dec number:		



### 3.4.8.3 Fan 1 Mode Configuration: CPU Smart Fan Auto Mode

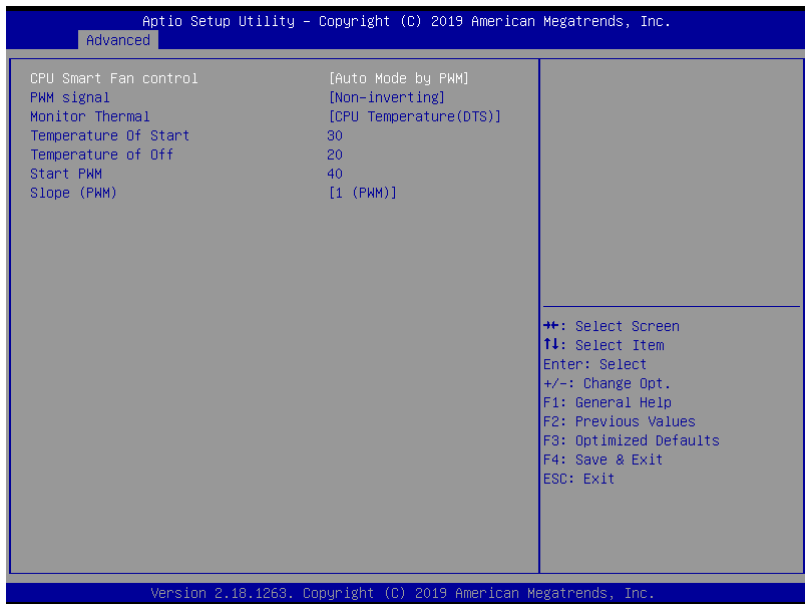

Options Summary		
Monitor Thermal	CPU Temperature(DTS)	Optimal Default, Failsafe Default
	Thermal Source 1(T1)	
	Thermal Source 2(T2)	
Select monitor thermal source		
Temperature of Start	30	Optimal Default, Failsafe Default
Temperature Of Start		
Temperature Of Off	20	Optimal Default, Failsafe Default
Temperature Of Off		
Start PWM	40	Optimal Default, Failsafe Default
Start PWM		
Slope (PWM)	0 (PWM)	
	1 (PWM)	Optimal Default, Failsafe Default
	2 (PWM)	
	4 (PWM)	
	8 (PWM)	
	16 (PWM)	
	32 (PWM)	
	64 (PWM)	
Slope (PWM)		

### 3.4.9 Advanced: Trusted Computing

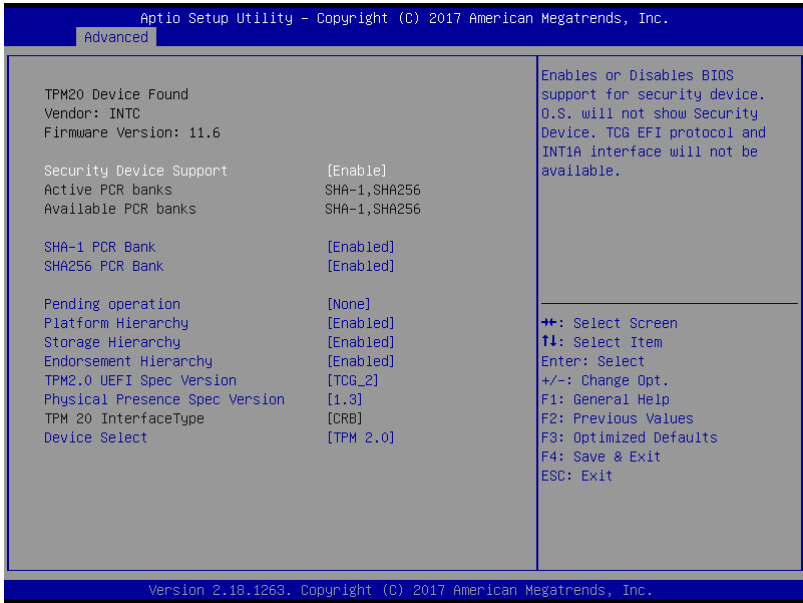

Options Summary		
Security Device Support	Disable	
	Enable	Optimal Default, Failsafe Default
Enables or Disables BIOS support for security device. O.S. will not show Security Device. TCG EFI protocol and INT1A interface will not be available.		
SHA-1 PCR Bank	Disable	
	Enable	Optimal Default, Failsafe Default
Enable or Disable SHA-1 PCR Bank		
SHA256 PCR Bank	Disable	
	Enable	Optimal Default, Failsafe Default
Enable or Disable SHA256 PCR Bank		
Pending operation	None	Optimal Default, Failsafe Default
	TPM Clear	
Schedule an Operation for the Security Device. NOTE: Your Computer will reboot during restart in order to change state of Security Device.		

Options Summary		
Platform Hierarchy	Disable	
	Enable	Optimal Default, Failsafe Default
Enable or Disable Platform Hierarchy		
Storage Hierarchy	Disable	
	Enable	Optimal Default, Failsafe Default
Enable or Disable Storage Hierarchy		
Endorsement Hierarchy	Disable	
	Enable	Optimal Default, Failsafe Default
Enable or Disable Endorsement Hierarchy		
TPM2.0 UEFI Spec Version	TCG_2	Optimal Default, Failsafe Default
	TCG_1_2	
Select the TCG2 Spec Version Support, TCG_1_2: the Compatible mode for Win8/Win10, TCG_2: Support new TCG2 protocol and event format for Win10 or later		
Physical Presence Spec Version	1.2	
	1.3	Optimal Default, Failsafe Default
Select to Tell O.S. to support PPI Spec Version 1.2 or 1.3. Note some HCK tests might not support 1.3.		
Device Select	TPM 2.0	Optimal Default, Failsafe Default
TPM 1.2 will restrict support to TPM 1.2 device, TPM 2.0 will restrict support to TPM 2.0 devices, Auto will support both with the default set to TPM 2.0 devices if not found, TPM 1.2 device will be enumerated.		

### 3.4.10 Advanced: Firmware Update Configuration

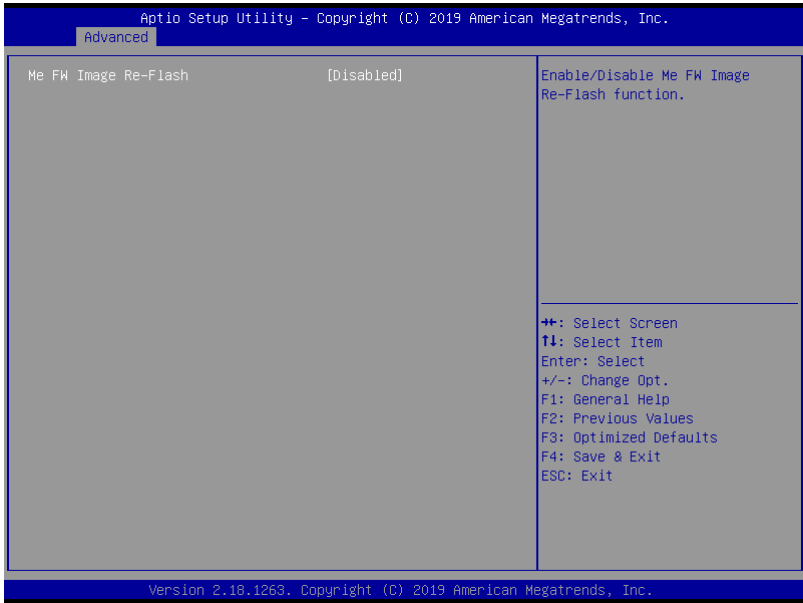

Options Summary		
Me FW Image	Disable	Optimal Default, Failsafe Default
Re-Flash	Enable	
Enable/ Disable Me FW Image Re-Flash functinn.		

### 3.5 Setup submenu: Chipset

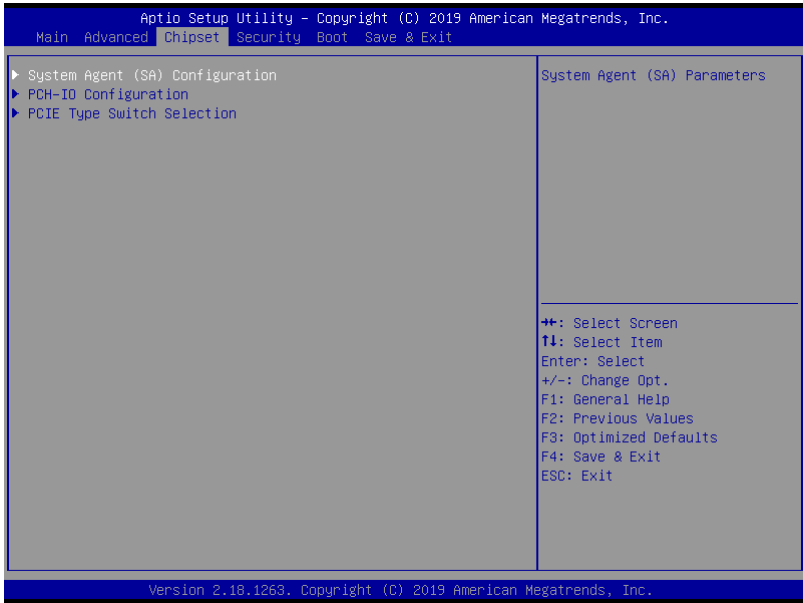

### 3.5.1 Chipset: System Agent (SA) Configuration

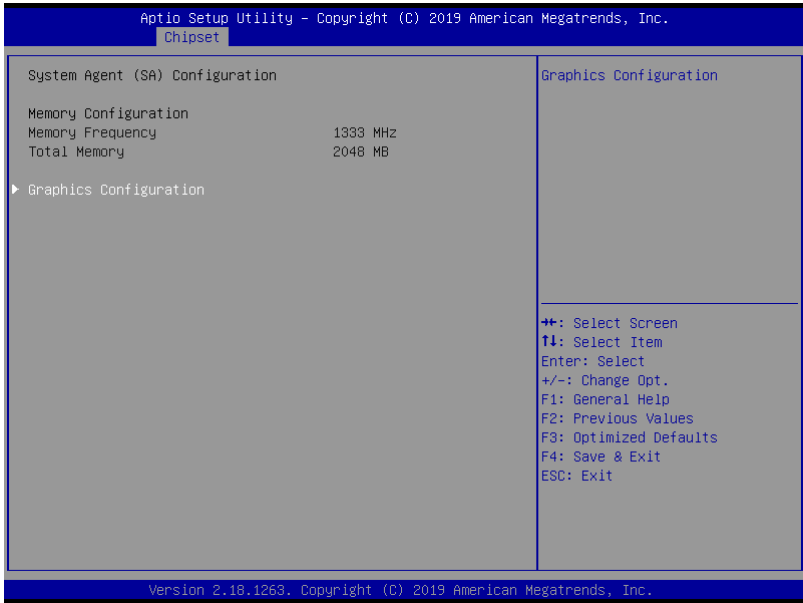

### 3.5.1.1 System Agent (SA): Graphics Configuration

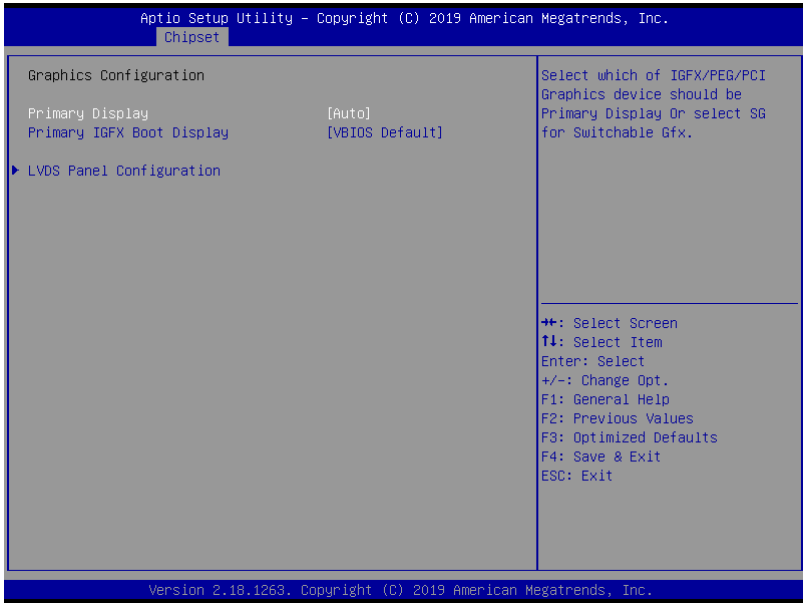

Options Summary		
Primary Display	Auto	Optimal Default, Failsafe Default
	IGFX	
	PEG	
Select which of IGFX/PEG/PCI Graphics device should be Primary Display Or select SG for Switchable Gfx.		
Primary IGFX Boot Display	VBIOS Default	Optimal Default, Failsafe Default
	DDI1/DP	
	DDI2/VGA	
	LVDS/eDP	
Select the Video Device which will be activated during POST. This has no effect if external graphic present. Secondary boot display selection will appear based on your selection. VGA modes will be supported only on primary display.		

### 3.5.1.2 Graphics Configuration: LVDS Panel Configuration

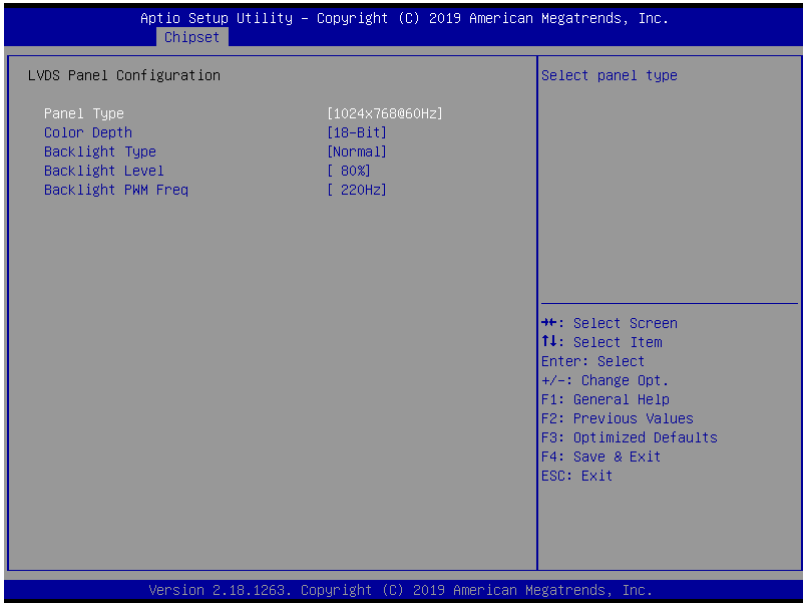

Options Summary		
Panel Type	640x480@60Hz	
	800x480@60Hz	
	800x600@60Hz	
	1024x600@60Hz	
	1024x768@60Hz	Optimal Default, Failsafe Default
	1280x768@60Hz	
	1280x800@60Hz	
	1280x1024@60Hz	
	1366x768@60Hz	
	1440x900@60Hz	
	1600x1200@60Hz	
	1920x1080@60Hz	
	1920x1200@60Hz	
Select panel type		



Options Summary		
Color Depth	18-bit	Optimal Default, Failsafe Default
	24-bit	
Select Color Depth		
Backlight Type	Normal	Optimal Default, Failsafe Default
	Inverted	
Select backlight control signal type		
Backlight Level	0%	
	10%	
	20%	
	30%	
	40%	
	50%	
	60%	
	70%	
	80%	Optimal Default, Failsafe Default
	90%	
100%		
Select backlight control level		
Backlight PWM Freq	100Hz	
	200Hz	
	220Hz	Optimal Default, Failsafe Default
	500Hz	
	1KHz	
	2.2KHz	
	6.5KHz	
Select PWM frequency of backlight control signal		

### 3.5.2 Chipset: PCH-IO Configuration

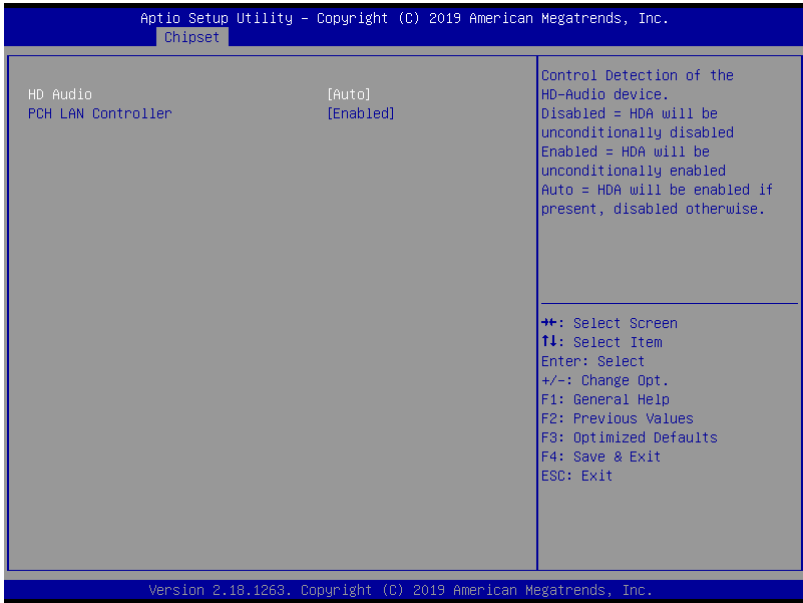

Options Summary		
HD Audio	Disabled	
	Enabled	
	Auto	Optimal Default, Failsafe Default
Control Detection of the HD-Audio device. Disabled = HDA will be unconditionally disabled Enabled = HDA will be unconditionally enabled Auto = HDA will be enabled if present, disabled otherwise.		
PCH LAN Controller	Enabled	Optimal Default, Failsafe Default
	Disabled	
Enable or disable onboard NIC.		

### 3.5.3 Chipset: PCIe Type Switch Selection

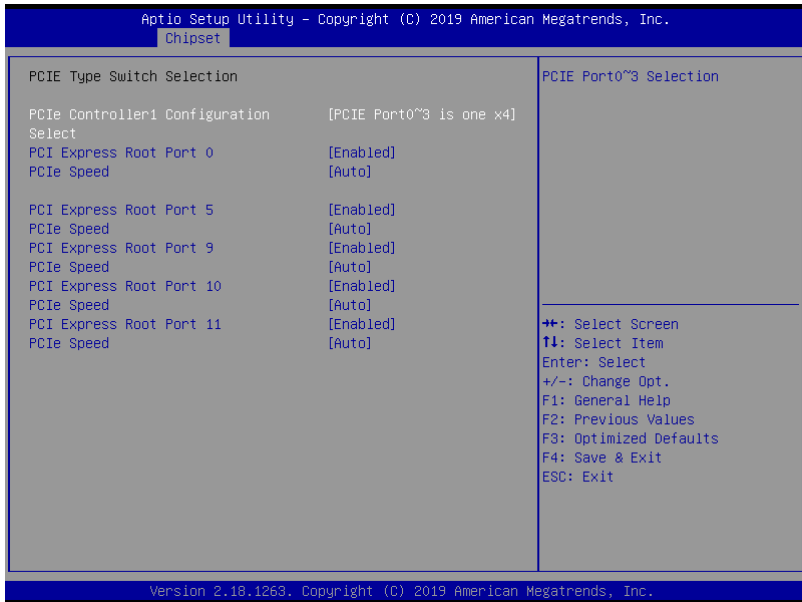

Options Summary		
PCIe Controller1 Configuration Select	PCIe Port0~3 are four X1	
	PCIe Port0~3 is one X4	Optimal Default, Failsafe Default
PCI Express Root Port * Selection.		
PCI Express Root Port 1	Disabled	
	Enabled	Optimal Default, Failsafe Default
Control the PCI Express Root Port.		
PCIe Speed	Auto	Optimal Default, Failsafe Default
	Gen1	
	Gen2	
	Gen3	
Configure PCIe Speed.		

## 3.6 Setup submenu: Security

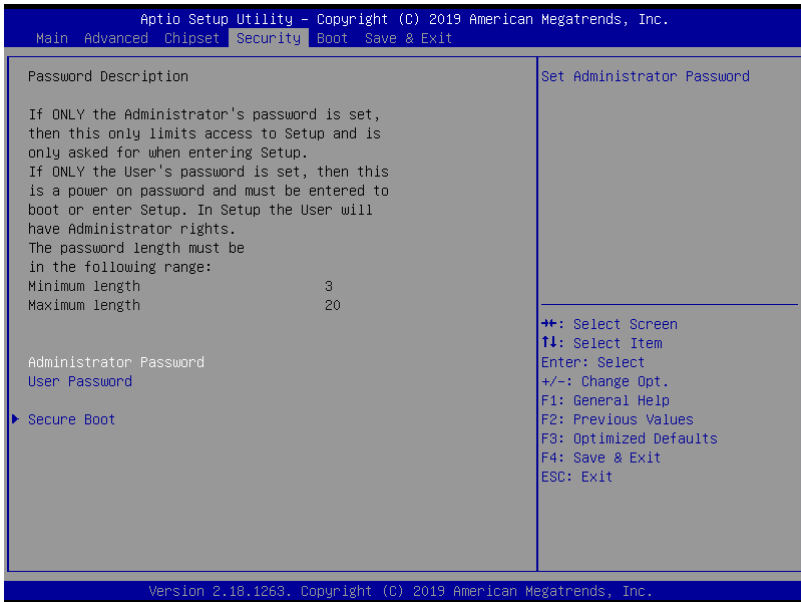

### Change Administrator/User Password

You can set an Administrator password. If you set an Administrator password, you can then set a User password. User passwords do not have access to many of the features in the Setup utility.

Select the password you want to set and press <Enter>. A dialog box will appear which lets you set the password. Passwords must be between 3 and 20 letters or numbers. Press <Enter> and re-enter the password into the next dialog box that appears. Press <Enter> after you have retyped it correctly. The password is required at boot time, or when the user enters the Setup utility.

### Remove Password

Highlight this item and type in the current password. At the next dialog box press <Enter> to disable password protection.

### 3.6.1 Security: Secure Boot

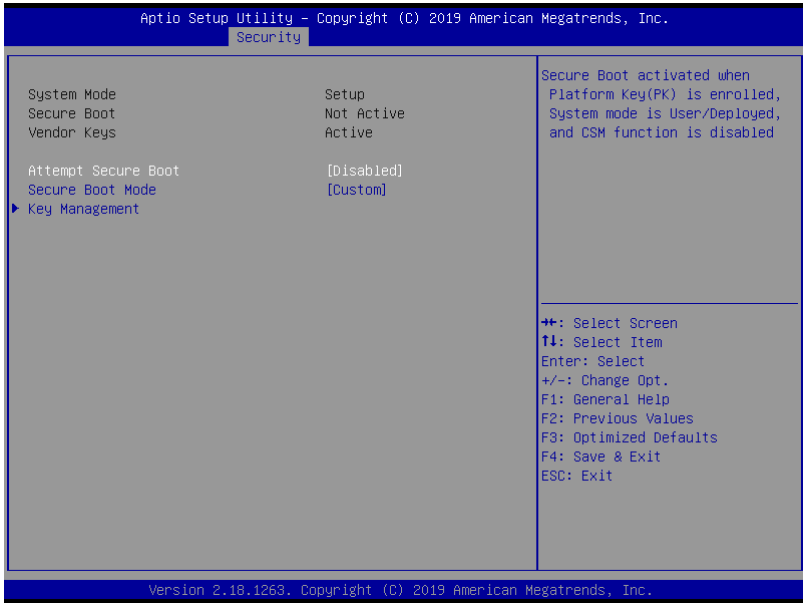

Options Summary		
<b>Attempt Secure Boot</b>	Disabled	Optimal Default, Failsafe Default
	Enabled	
Secure Boot activated when Platform Key(PK) is enrolled, System mode is User/Deployed, and CSM function is disable		
<b>Secure Boot Mode</b>	Standard	
	Custom	Optimal Default, Failsafe Default
Secure Boot Mode selector: Standard/Custom. In Custom mode Secure Boot Variables can be configured without authentication		

### 3.6.1.1 Secure Boot: Key Management

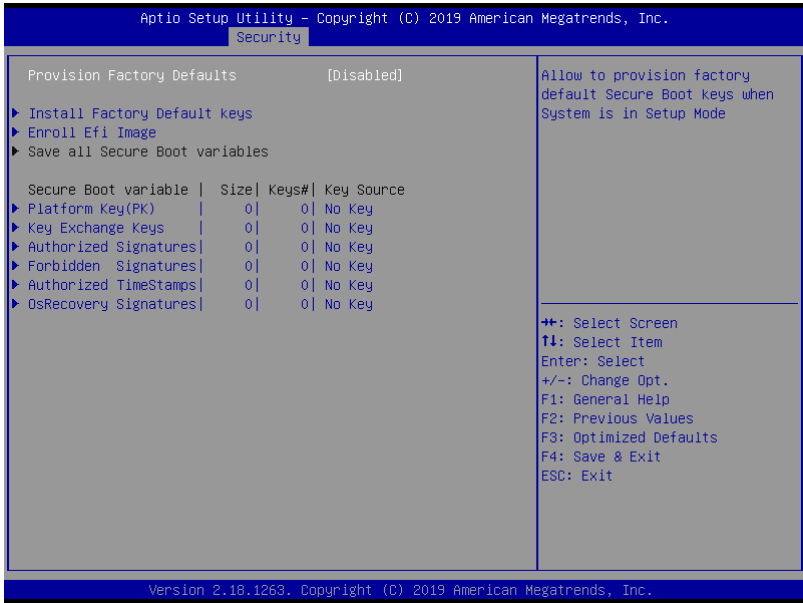

Options Summary		
Provision Factory Defaults	Disabled	Optimal Default, Failsafe Default
	Enabled	
Allow to provision factory default Secure Boot keys when System is in setup Mode		
Install Factory Default keys		
Force System to User Mode - install all Factory Default keys		
Enroll Efi Image		
Allow the image to run in Secure Boot mode.		
Enroll SHA256 hash of the binary into Authorized Signature Database (db)		

*Table Continues on next page.*

Options Summary	
<b>Platform Key(PK)</b>	
Enroll Factory Defaults or load certificates from a file: 1.Public Key Certificate in: a)EFI_SIGNATURE_LIST b)EFI_CERT_X509 (DER encoded) c)EFI_CERT_RSA2048 (bin) d)EFI_CERT_SHA256,384,512 2.Authenticated UEFI Variable 3.EFI PE/COFF Image(SHA256) Key Source: Default,External,Mixed,Test	
<b>Key Exchange Keys</b>	
Enroll Factory Defaults or load certificates from a file: 1.Public Key Certificate in: a)EFI_SIGNATURE_LIST b)EFI_CERT_X509 (DER encoded) c)EFI_CERT_RSA2048 (bin) d)EFI_CERT_SHA256,384,512 2.Authenticated UEFI Variable 3.EFI PE/COFF Image(SHA256) Key Source: Default,External,Mixed,Test	
<b>Authorized Signatures</b>	
Enroll Factory Defaults or load certificates from a file: 1.Public Key Certificate in: a)EFI_SIGNATURE_LIST b)EFI_CERT_X509 (DER encoded) c)EFI_CERT_RSA2048 (bin) d)EFI_CERT_SHA256,384,512 2.Authenticated UEFI Variable 3.EFI PE/COFF Image(SHA256) Key Source: Default,External,Mixed,Test	

*Table Continues on next page.*

Options Summary	
<b>Forbidden Signatures</b>	
Enroll Factory Defaults or load certificates from a file: 1.Public Key Certificate in: a)EFI_SIGNATURE_LIST b)EFI_CERT_X509 (DER encoded) c)EFI_CERT_RSA2048 (bin) d)EFI_CERT_SHA256,384,512 2.Authenticated UEFI Variable 3.EFI PE/COFF Image(SHA256) Key Source: Default,External,Mixed,Test	
<b>Authorized TimeStamps</b>	
Enroll Factory Defaults or load certificates from a file: 1.Public Key Certificate in: a)EFI_SIGNATURE_LIST b)EFI_CERT_X509 (DER encoded) c)EFI_CERT_RSA2048 (bin) d)EFI_CERT_SHA256,384,512 2.Authenticated UEFI Variable 3.EFI PE/COFF Image(SHA256) Key Source: Default,External,Mixed,Test	
<b>OsRecovery Signatures</b>	
Enroll Factory Defaults or load certificates from a file: 1.Public Key Certificate in: a)EFI_SIGNATURE_LIST b)EFI_CERT_X509 (DER encoded) c)EFI_CERT_RSA2048 (bin) d)EFI_CERT_SHA256,384,512 2.Authenticated UEFI Variable 3.EFI PE/COFF Image(SHA256) Key Source: Default,External,Mixed,Test	



### 3.7 Setup submenu: Boot

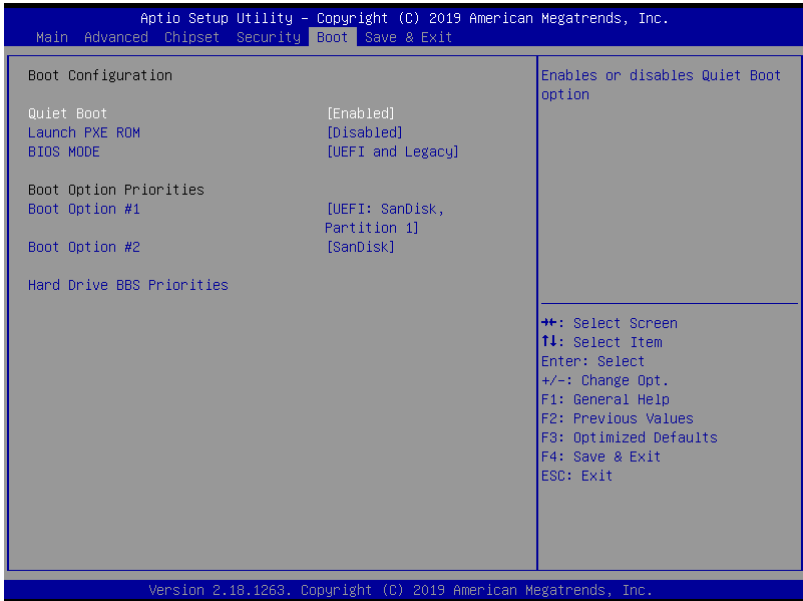

Options Summary		
Quiet Boot	Disabled	
	Enabled	Optimal Default, Failsafe Default
Enables or Disables Quiet Boot option.		
Launch PXE Boot	Disabled	Optimal Default, Failsafe Default
	UEFI	
	Legacy	
Controls the execution of UEFI and Legacy PXE OpROM.		
BIOS MODE	UEFI and Legacy	Optimal Default, Failsafe Default
	UEFI only	
Select using BIOS mode.		

### 3.7.1 Boot: Hard Drive BBS Priorities

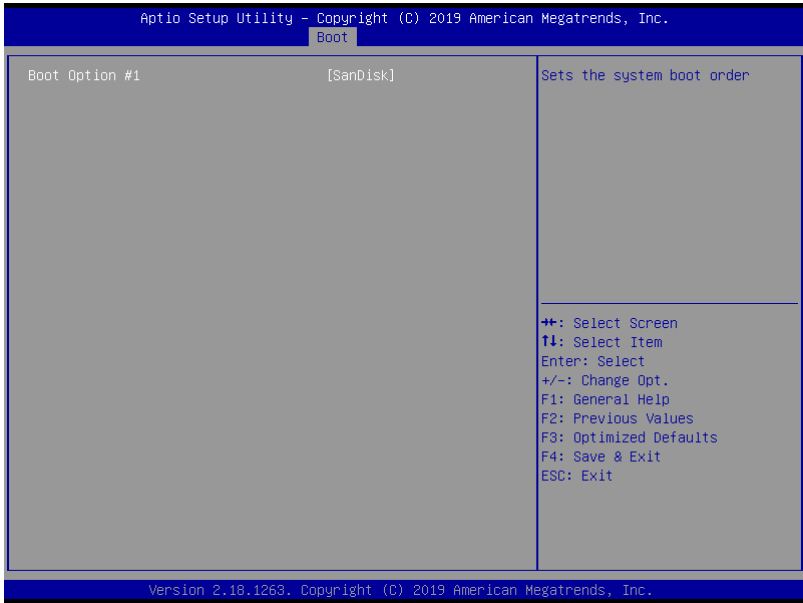

### 3.8 Setup submenu: Save & Exit

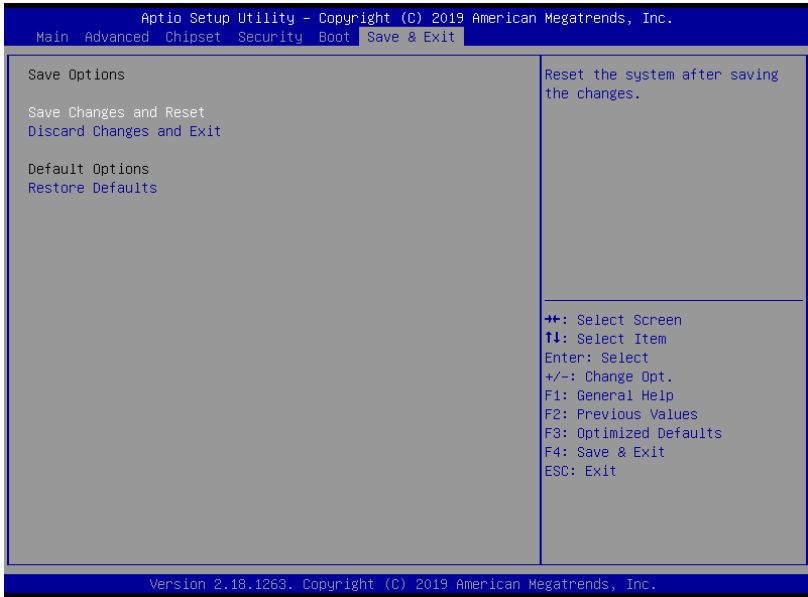

# Chapter 4

---

Drivers Installation

## 4.1 Driver Download/Installation

---

Drivers for the COM-KBUC6/SKUC6 can be downloaded from the product page on the AAEON website by following this link:

<https://www.aaeon.com/en/p/com-express-modules-com-kbuc6>

Download the driver(s) you need and follow the steps below to install them.

### 4.1.1 COM-KBUC6 Driver Installation Steps

---

#### Step 1 – Install Chipset Driver

1. Click the **Step1 - Chipset** folder followed by **SetupChipset.exe**
2. Follow the instructions
3. Drivers will be installed automatically

#### Step 2 – Install Graphics Driver

1. Click the **Step2 - Graphic** folder and select your OS
2. Click the **Setup.exe** file in the folder
3. Follow the instructions
4. Drivers will be installed automatically

#### Step 3 – Install LAN Driver

1. Click the **Step3 - LAN** folder then the **Windows** folder.
2. Click the **ProWinx64.exe** file in the folder.
3. Follow the instructions
4. Drivers will be installed automatically

#### Step 4 – Install Audio Driver

1. Click the **STEP4 - Audio** folder followed by **0008-64bit\_Win7\_Win8\_Win81\_Win10\_R281.exe**
2. Follow the instructions
3. Drivers will be installed automatically

#### Step 5 – Install ME Driver

1. Click the **STEP5 - ME** folder followed by **SetupME.exe**
2. Follow the instructions
3. Drivers will be installed automatically

#### Step 6 – Install ACPI Driver

1. Click the **STEP6 - InterruptDIO** folder and select your OS
2. Follow the instructions in **ACPI Driver Test SOP.docx** to install and test ACPI drivers.

## 4.1.2 COM-SKUC6 Driver Installation Steps

---

### Step 1 – Install Chipset Driver

1. Click the **Step1 - Chipset** folder followed by **SetupChipset.exe**
2. Follow the instructions
3. Drivers will be installed automatically

### Step 2 – Install Graphics Driver

1. Click the **Step2 - Graphic** folder and select your OS
2. Click the **Setup.exe** file in the folder
3. Follow the instructions
4. Drivers will be installed automatically

### Step 3 – Install LAN Driver

1. Click the **Step3 - LAN** folder then select your OS.
2. For Linux, Click the **igb-5.3.3.2** folder and follow the instructions in **README**
3. For Windows, Click **Autorun.exe** and follow the instructions. Drivers will be installed automatically.

### Step 4 – Install Audio Driver

1. Click the **STEP4 - Audio** folder followed by **win7\_win8\_1** folder.
2. Click **0002-Win7\_Win8\_Win81\_R276.exe**
3. Follow the instructions
4. Drivers will be installed automatically

### Step 5 – Install USB 3.0 (Windows 7 only)

1. Click the **STEP5 – USB 3.0** folder followed by **Win7** folder
2. Click **Setup.exe**
3. Follow the instructions
4. Drivers will be installed automatically

### Step 6 – Install ME Driver

1. Click the **STEP5 - ME** folder followed by **Windows** folder.
2. Click **Setup.exe**
3. Follow the instructions
4. Drivers will be installed automatically

### Step 7 – Install ACPI Driver

1. Click the **STEP6 - InterruptDIO** folder and select your OS
2. Follow the instructions in **ACPI Driver Test SOP.docx** to install and test ACPI drivers.



# Appendix A

---

## Watchdog Timer Programming

## A.1 Watchdog Timer Initial Program

Table 1 : Embedded BRAM relative register table

	Default Value	Note
Index	0x284(Note1)	BRAM Index Register
Data	0x285(Note2)	BRAM Data Register
Logical Device Number	0xA8(Note3)	Watch dog Logical Device Number
Function and Device Number	0x00(Note4)	Watch dog Function/Device Number

Table 2 : Watchdog relative register table

	Option Register	BitNum	Value	Note
Timer Counter	0x00(Note5)		(Note10)	Time of watchdog timer (0~255)
Counting Unit	0x01(Note6)	0(Note7)	0(Note11)	Select time unit. 0: second 1: minute
Watchdog RST pulse width	0x01(Note8)	[3:2](Note9)	0(Note12)	0: 20ms 1: 60ms 2: 100ms 3: 250ms

```
*****
// Embedded BRAM relative definition (Please reference to Table 1)
#define byte EcBRAMIndex //This parameter is represented from Note1
#define byte EcBRAMData //This parameter is represented from Note2
#define byte BRAMLDRReg //This parameter is represented from Note3
#define byte BRAMFnDataReg //This parameter is represented from Note4
#define void EcBRAMWriteByte(byte Offset, byte Value);
#define byte EcBRAMReadByte(byte Offset);
#define void IOWriteByte(byte Offset, byte Value);
#define byte IOReadByte(byte Offset);
// Watch Dog relative definition (Please reference to Table 2)
#define byte TimerReg //This parameter is represented from Note5
#define byte TimerVal // This parameter is represented from Note10
#define byte UnitReg //This parameter is represented from Note6
#define byte UnitBit //This parameter is represented from Note7
#define byte UnitVal //This parameter is represented from Note11
#define byte RSTReg //This parameter is represented from Note8
#define byte RSTBit //This parameter is represented from Note9
#define byte RSTVal //This parameter is represented from Note12
*****
```

```
*****  
VOID Main()  
    // Procedure : AaeonWDTConfig  
    // (byte)Timer : Time of WDT timer.(0x00~0xFF)  
    // (boolean)Unit : Select time unit(0: second, 1: minute).  
    AaeonWDTConfig();  
  
    // Procedure : AaeonWDTEnable  
    // This procedure will enable the WDT counting.  
    AaeonWDTEnable();  
}  
*****
```

```

*****
// Procedure : AaeonWDTEnable
VOID AaeonWDTEnable (){
    WDTEnableDisable(1);
}

// Procedure : AaeonWDTConfig
VOID AaeonWDTConfig (){
    // Disable WDT counting
    WDTEnableDisable(0);
    // WDT relative parameter setting
    WDTParameterSetting();
}

VOID WDTEnableDisable(byte Value){
    ECBRAMWriteByte(TimerReg , Value);
}

VOID WDTParameterSetting(){
    Byte TempByte;

    // Watchdog Timer counter setting
    ECBRAMWriteByte(TimerReg , TimerVal);
    // WDT counting unit setting
    TempByte = ECBRAMReadByte(UnitReg);
    TempByte |= (UnitVal << UnitBit);
    ECBRAMWriteByte(UnitReg , TempByte);
    // WDT RST pulse width setting
    TempByte = ECBRAMReadByte(RSTReg);
    TempByte |= (RSTVal << RSTBit);
    ECBRAMWriteByte(RSTReg , TempByte);
}
*****

```

```
*****
VOID ECBRAMWriteByte(byte OPReg, byte OPBit, byte Value){
    IOWriteByte(EcBRAMIndex, 0x10);
    IOWriteByte(EcBRAMData, BRAMLDNReg);
    IOWriteByte(EcBRAMIndex, 0x11);
    IOWriteByte(EcBRAMData, BRAMFnDataReg);

    IOWriteByte(EcBRAMIndex, 0x13 + OPReg);
    IOWriteByte(EcBRAMData, Value);

    IOWriteByte(EcBRAMIndex, 0x12);
    IOWriteByte(EcBRAMData, 0x30);           //Write start
}

Byte ECBRAMReadByte(byte OPReg){
    IOWriteByte(EcBRAMIndex, 0x10);
    IOWriteByte(EcBRAMData, BRAMLDNReg);
    IOWriteByte(EcBRAMIndex, 0x11);
    IOWriteByte(EcBRAMData, BRAMFnDataReg);

    IOWriteByte(EcBRAMIndex, 0x12);
    IOWriteByte(EcBRAMData, 0x10);         //Read start

    IOWriteByte(EcBRAMIndex, 0x13 + OPReg);
    Return      IOReadByte(EcBRAMData, Value);
}
*****
```

# Appendix B

---

I/O Information

## B.1 I/O Address Map

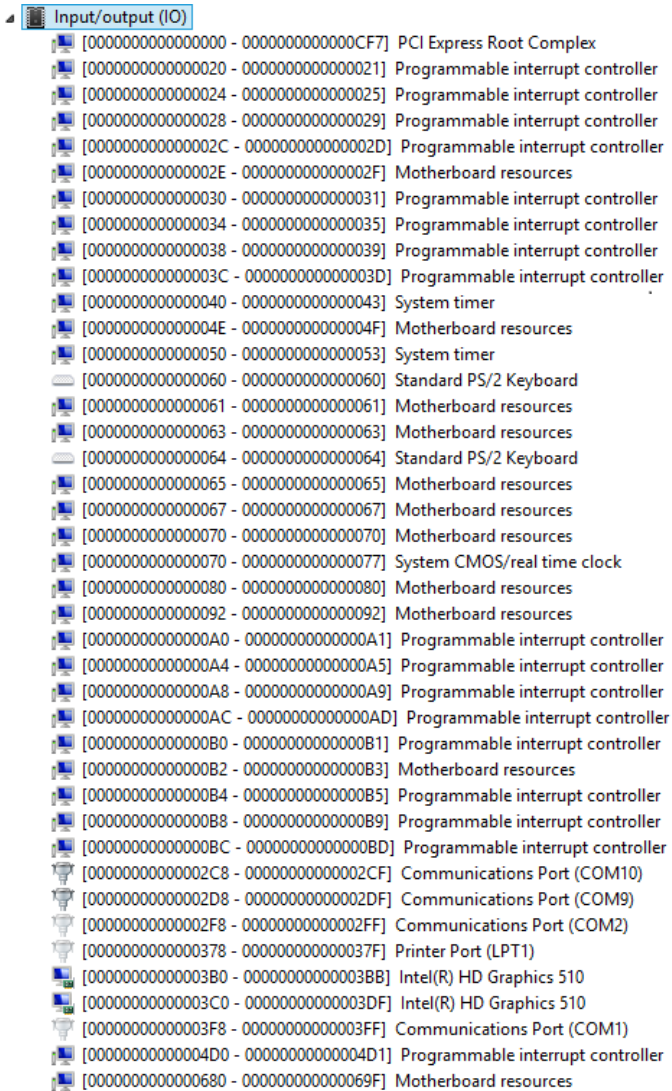

Address Range	Component Name
[0000000000000000 - 00000000000000CF7]	PCI Express Root Complex
[00000000000000020 - 00000000000000021]	Programmable interrupt controller
[00000000000000024 - 00000000000000025]	Programmable interrupt controller
[00000000000000028 - 00000000000000029]	Programmable interrupt controller
[0000000000000002C - 0000000000000002D]	Programmable interrupt controller
[0000000000000002E - 0000000000000002F]	Motherboard resources
[00000000000000030 - 00000000000000031]	Programmable interrupt controller
[00000000000000034 - 00000000000000035]	Programmable interrupt controller
[00000000000000038 - 00000000000000039]	Programmable interrupt controller
[0000000000000003C - 0000000000000003D]	Programmable interrupt controller
[00000000000000040 - 00000000000000043]	System timer
[0000000000000004E - 0000000000000004F]	Motherboard resources
[00000000000000050 - 00000000000000053]	System timer
[00000000000000060 - 00000000000000060]	Standard PS/2 Keyboard
[00000000000000061 - 00000000000000061]	Motherboard resources
[00000000000000063 - 00000000000000063]	Motherboard resources
[00000000000000064 - 00000000000000064]	Standard PS/2 Keyboard
[00000000000000065 - 00000000000000065]	Motherboard resources
[00000000000000067 - 00000000000000067]	Motherboard resources
[00000000000000070 - 00000000000000070]	Motherboard resources
[00000000000000070 - 00000000000000077]	System CMOS/real time clock
[00000000000000080 - 00000000000000080]	Motherboard resources
[00000000000000092 - 00000000000000092]	Motherboard resources
[000000000000000A0 - 000000000000000A1]	Programmable interrupt controller
[000000000000000A4 - 000000000000000A5]	Programmable interrupt controller
[000000000000000A8 - 000000000000000A9]	Programmable interrupt controller
[000000000000000AC - 000000000000000AD]	Programmable interrupt controller
[000000000000000B0 - 000000000000000B1]	Programmable interrupt controller
[000000000000000B2 - 000000000000000B3]	Motherboard resources
[000000000000000B4 - 000000000000000B5]	Programmable interrupt controller
[000000000000000B8 - 000000000000000B9]	Programmable interrupt controller
[000000000000000BC - 000000000000000BD]	Programmable interrupt controller
[000000000000000C8 - 000000000000000CF]	Communications Port (COM10)
[000000000000000D8 - 000000000000000DF]	Communications Port (COM9)
[000000000000000F8 - 000000000000000FF]	Communications Port (COM2)
[00000000000000378 - 0000000000000037F]	Printer Port (LPT1)
[000000000000003B0 - 000000000000003BB]	Intel(R) HD Graphics 510
[000000000000003C0 - 000000000000003DF]	Intel(R) HD Graphics 510
[000000000000003F8 - 000000000000003FF]	Communications Port (COM1)
[000000000000004D0 - 000000000000004D1]	Programmable interrupt controller
[00000000000000680 - 0000000000000069F]	Motherboard resources





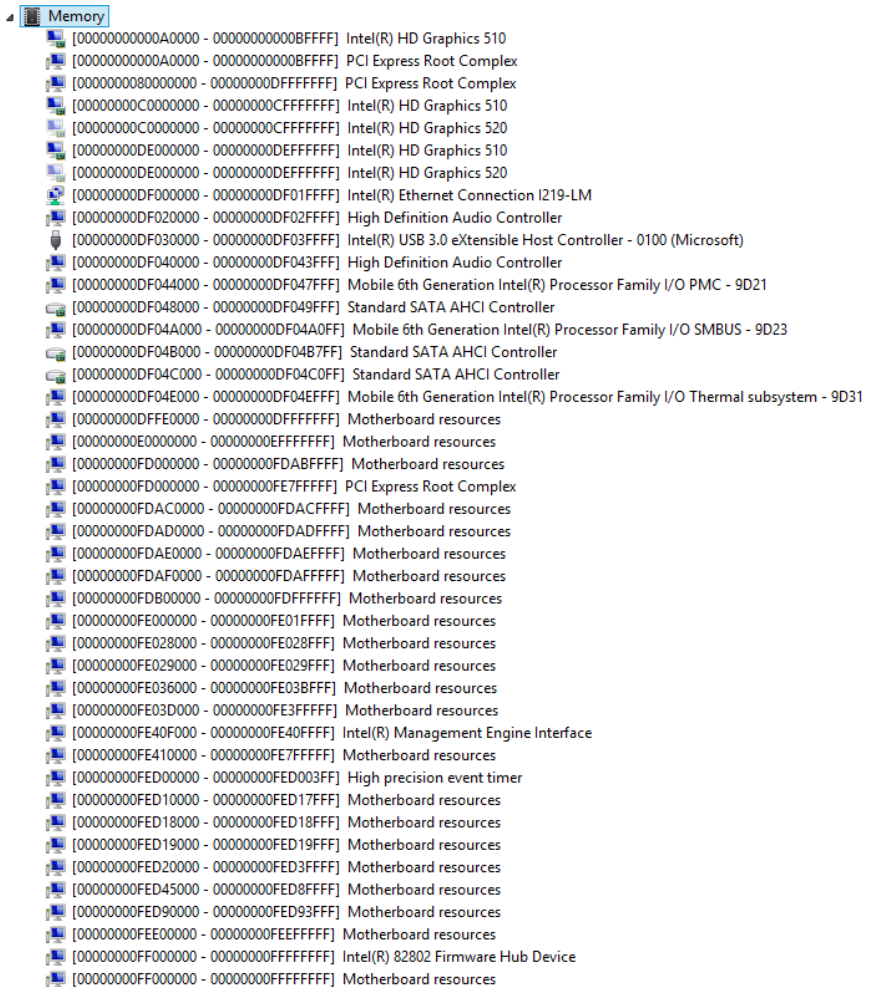





































## B.2 Memory Address Map

















































































The image shows a screenshot of the Windows System Information tool, specifically the 'Memory' section. It displays a list of memory addresses and their corresponding hardware components. The list includes various Intel(R) HD Graphics, PCI Express Root Complex, Ethernet Connection I219-LM, High Definition Audio Controller, Intel(R) USB 3.0 eXtensible Host Controller - 0100 (Microsoft), Mobile 6th Generation Intel(R) Processor Family I/O PMC - 9D21, Standard SATA AHCI Controller, Mobile 6th Generation Intel(R) Processor Family I/O SMBUS - 9D23, Mobile 6th Generation Intel(R) Processor Family I/O Thermal subsystem - 9D31, and Motherboard resources.











































Memory Address Range	Hardware Component
[0000000000A0000 - 0000000000BFFFFF]	Intel(R) HD Graphics 510
[0000000000A0000 - 0000000000BFFFFF]	PCI Express Root Complex
[0000000080000000 - 00000000DFFFFFFF]	PCI Express Root Complex
[00000000C0000000 - 00000000CFFFFFFF]	Intel(R) HD Graphics 510
[00000000C0000000 - 00000000CFFFFFFF]	Intel(R) HD Graphics 520
[00000000DE000000 - 00000000DEFFFFFF]	Intel(R) HD Graphics 510
[00000000DE000000 - 00000000DEFFFFFF]	Intel(R) HD Graphics 520
[00000000DF000000 - 00000000DF1FFFFF]	Intel(R) Ethernet Connection I219-LM
[00000000DF020000 - 00000000DF02FFFF]	High Definition Audio Controller
[00000000DF030000 - 00000000DF03FFFF]	Intel(R) USB 3.0 eXtensible Host Controller - 0100 (Microsoft)
[00000000DF040000 - 00000000DF043FFF]	High Definition Audio Controller
[00000000DF044000 - 00000000DF047FFF]	Mobile 6th Generation Intel(R) Processor Family I/O PMC - 9D21
[00000000DF048000 - 00000000DF049FFF]	Standard SATA AHCI Controller
[00000000DF04A000 - 00000000DF04AFFF]	Mobile 6th Generation Intel(R) Processor Family I/O SMBUS - 9D23
[00000000DF04B000 - 00000000DF04BFFF]	Standard SATA AHCI Controller
[00000000DF04C000 - 00000000DF04CFFF]	Standard SATA AHCI Controller
[00000000DF04E000 - 00000000DF04EFFF]	Mobile 6th Generation Intel(R) Processor Family I/O Thermal subsystem - 9D31
[00000000DFFE0000 - 00000000DFFFFFFF]	Motherboard resources
[00000000DE000000 - 00000000EFFFFFFF]	Motherboard resources
[00000000FD000000 - 00000000FDABFFFF]	Motherboard resources
[00000000FD000000 - 00000000FE7FFFFF]	PCI Express Root Complex
[00000000FDAC0000 - 00000000FDACFFFF]	Motherboard resources
[00000000FDAD0000 - 00000000FDADFFFF]	Motherboard resources
[00000000FDAE0000 - 00000000FDAEFFFF]	Motherboard resources
[00000000FDAF0000 - 00000000FDAFFFFF]	Motherboard resources
[00000000FDB00000 - 00000000FDFFFFFF]	Motherboard resources
[00000000FE000000 - 00000000FE01FFFF]	Motherboard resources
[00000000FE028000 - 00000000FE028FFF]	Motherboard resources
[00000000FE029000 - 00000000FE029FFF]	Motherboard resources
[00000000FE036000 - 00000000FE03BFFF]	Motherboard resources
[00000000FE03D000 - 00000000FE3FFFFF]	Motherboard resources
[00000000FE40F000 - 00000000FE40FFFF]	Intel(R) Management Engine Interface
[00000000FE410000 - 00000000FE7FFFFF]	Motherboard resources
[00000000FED00000 - 00000000FED003FF]	High precision event timer
[00000000FED10000 - 00000000FED17FFF]	Motherboard resources
[00000000FED18000 - 00000000FED18FFF]	Motherboard resources
[00000000FED19000 - 00000000FED19FFF]	Motherboard resources
[00000000FED20000 - 00000000FED3FFFF]	Motherboard resources
[00000000FED45000 - 00000000FED8FFFF]	Motherboard resources
[00000000FED90000 - 00000000FED93FFF]	Motherboard resources
[00000000FEE00000 - 00000000FEEFFFFF]	Motherboard resources
[00000000FF000000 - 00000000FFFFFFF]	Intel(R) 82802 Firmware Hub Device
[00000000FF000000 - 00000000FFFFFFF]	Motherboard resources











































## B.3 IRQ Mapping Chart

Interrupt request (IRQ)	
	(ISA) 0x00000000 (00) System timer
	(ISA) 0x00000001 (01) Standard PS/2 Keyboard
	(ISA) 0x00000003 (03) Communications Port (COM2)
	(ISA) 0x00000004 (04) Communications Port (COM1)
	(ISA) 0x00000005 (05) Printer Port (LPT1)
	(ISA) 0x00000008 (08) System CMOS/real time clock
	(ISA) 0x0000000A (10) Communications Port (COM10)
	(ISA) 0x0000000B (11) Communications Port (COM9)
	(ISA) 0x0000000B (11) Intel(R) HD Graphics 520
	(ISA) 0x0000000C (12) Logitech PS/2 Port Mouse
	(ISA) 0x0000000E (14) Motherboard resources
	(ISA) 0x00000051 (81) Microsoft ACPI-Compliant System
	(ISA) 0x00000052 (82) Microsoft ACPI-Compliant System
	(ISA) 0x00000053 (83) Microsoft ACPI-Compliant System
	(ISA) 0x00000054 (84) Microsoft ACPI-Compliant System
	(ISA) 0x00000055 (85) Microsoft ACPI-Compliant System
	(ISA) 0x00000056 (86) Microsoft ACPI-Compliant System
	(ISA) 0x00000057 (87) Microsoft ACPI-Compliant System
	(ISA) 0x00000058 (88) Microsoft ACPI-Compliant System
	(ISA) 0x00000059 (89) Microsoft ACPI-Compliant System
	(ISA) 0x0000005A (90) Microsoft ACPI-Compliant System
	(ISA) 0x0000005B (91) Microsoft ACPI-Compliant System
	(ISA) 0x0000005C (92) Microsoft ACPI-Compliant System
	(ISA) 0x0000005D (93) Microsoft ACPI-Compliant System
	(ISA) 0x0000005E (94) Microsoft ACPI-Compliant System
	(ISA) 0x0000005F (95) Microsoft ACPI-Compliant System
	(ISA) 0x00000060 (96) Microsoft ACPI-Compliant System
	(ISA) 0x00000061 (97) Microsoft ACPI-Compliant System
	(ISA) 0x00000062 (98) Microsoft ACPI-Compliant System
	(ISA) 0x00000063 (99) Microsoft ACPI-Compliant System
	(ISA) 0x00000064 (100) Microsoft ACPI-Compliant System
	(ISA) 0x00000065 (101) Microsoft ACPI-Compliant System
	(ISA) 0x00000066 (102) Microsoft ACPI-Compliant System
	(ISA) 0x00000067 (103) Microsoft ACPI-Compliant System
	(ISA) 0x00000068 (104) Microsoft ACPI-Compliant System
	(ISA) 0x00000069 (105) Microsoft ACPI-Compliant System
	(ISA) 0x0000006A (106) Microsoft ACPI-Compliant System
	(ISA) 0x0000006B (107) Microsoft ACPI-Compliant System
	(ISA) 0x0000006C (108) Microsoft ACPI-Compliant System
	(ISA) 0x0000006D (109) Microsoft ACPI-Compliant System
	(ISA) 0x0000006E (110) Microsoft ACPI-Compliant System











































 (ISA) 0x0000006F (111)	Microsoft ACPI-Compliant System
 (ISA) 0x00000070 (112)	Microsoft ACPI-Compliant System
 (ISA) 0x00000071 (113)	Microsoft ACPI-Compliant System
 (ISA) 0x00000072 (114)	Microsoft ACPI-Compliant System
 (ISA) 0x00000073 (115)	Microsoft ACPI-Compliant System
 (ISA) 0x00000074 (116)	Microsoft ACPI-Compliant System
 (ISA) 0x00000075 (117)	Microsoft ACPI-Compliant System
 (ISA) 0x00000076 (118)	Microsoft ACPI-Compliant System
 (ISA) 0x00000077 (119)	Microsoft ACPI-Compliant System
 (ISA) 0x00000078 (120)	Microsoft ACPI-Compliant System
 (ISA) 0x00000079 (121)	Microsoft ACPI-Compliant System
 (ISA) 0x0000007A (122)	Microsoft ACPI-Compliant System
 (ISA) 0x0000007B (123)	Microsoft ACPI-Compliant System
 (ISA) 0x0000007C (124)	Microsoft ACPI-Compliant System
 (ISA) 0x0000007D (125)	Microsoft ACPI-Compliant System
 (ISA) 0x0000007E (126)	Microsoft ACPI-Compliant System
 (ISA) 0x0000007F (127)	Microsoft ACPI-Compliant System
 (ISA) 0x00000080 (128)	Microsoft ACPI-Compliant System
 (ISA) 0x00000081 (129)	Microsoft ACPI-Compliant System
 (ISA) 0x00000082 (130)	Microsoft ACPI-Compliant System
 (ISA) 0x00000083 (131)	Microsoft ACPI-Compliant System
 (ISA) 0x00000084 (132)	Microsoft ACPI-Compliant System
 (ISA) 0x00000085 (133)	Microsoft ACPI-Compliant System
 (ISA) 0x00000086 (134)	Microsoft ACPI-Compliant System
 (ISA) 0x00000087 (135)	Microsoft ACPI-Compliant System
 (ISA) 0x00000088 (136)	Microsoft ACPI-Compliant System
 (ISA) 0x00000089 (137)	Microsoft ACPI-Compliant System
 (ISA) 0x0000008A (138)	Microsoft ACPI-Compliant System
 (ISA) 0x0000008B (139)	Microsoft ACPI-Compliant System
 (ISA) 0x0000008C (140)	Microsoft ACPI-Compliant System
 (ISA) 0x0000008D (141)	Microsoft ACPI-Compliant System
 (ISA) 0x0000008E (142)	Microsoft ACPI-Compliant System
 (ISA) 0x0000008F (143)	Microsoft ACPI-Compliant System
 (ISA) 0x00000090 (144)	Microsoft ACPI-Compliant System
 (ISA) 0x00000091 (145)	Microsoft ACPI-Compliant System
 (ISA) 0x00000092 (146)	Microsoft ACPI-Compliant System
(ISA) 0x00000093 (147)	Microsoft ACPI-Compliant System
(ISA) 0x00000094 (148)	Microsoft ACPI-Compliant System
(ISA) 0x00000095 (149)	Microsoft ACPI-Compliant System
(ISA) 0x00000096 (150)	Microsoft ACPI-Compliant System
(ISA) 0x00000097 (151)	Microsoft ACPI-Compliant System
(ISA) 0x00000098 (152)	Microsoft ACPI-Compliant System











































 (ISA) 0x00000099 (153)	Microsoft ACPI-Compliant System
 (ISA) 0x0000009A (154)	Microsoft ACPI-Compliant System
 (ISA) 0x0000009B (155)	Microsoft ACPI-Compliant System
 (ISA) 0x0000009C (156)	Microsoft ACPI-Compliant System
 (ISA) 0x0000009D (157)	Microsoft ACPI-Compliant System
 (ISA) 0x0000009E (158)	Microsoft ACPI-Compliant System
 (ISA) 0x0000009F (159)	Microsoft ACPI-Compliant System
 (ISA) 0x000000A0 (160)	Microsoft ACPI-Compliant System
 (ISA) 0x000000A1 (161)	Microsoft ACPI-Compliant System
 (ISA) 0x000000A2 (162)	Microsoft ACPI-Compliant System
 (ISA) 0x000000A3 (163)	Microsoft ACPI-Compliant System
 (ISA) 0x000000A4 (164)	Microsoft ACPI-Compliant System
 (ISA) 0x000000A5 (165)	Microsoft ACPI-Compliant System
 (ISA) 0x000000A6 (166)	Microsoft ACPI-Compliant System
 (ISA) 0x000000A7 (167)	Microsoft ACPI-Compliant System
 (ISA) 0x000000A8 (168)	Microsoft ACPI-Compliant System
 (ISA) 0x000000A9 (169)	Microsoft ACPI-Compliant System
 (ISA) 0x000000AA (170)	Microsoft ACPI-Compliant System
 (ISA) 0x000000AB (171)	Microsoft ACPI-Compliant System
 (ISA) 0x000000AC (172)	Microsoft ACPI-Compliant System
 (ISA) 0x000000AD (173)	Microsoft ACPI-Compliant System
 (ISA) 0x000000AE (174)	Microsoft ACPI-Compliant System
 (ISA) 0x000000AF (175)	Microsoft ACPI-Compliant System
 (ISA) 0x000000B0 (176)	Microsoft ACPI-Compliant System
 (ISA) 0x000000B1 (177)	Microsoft ACPI-Compliant System
 (ISA) 0x000000B2 (178)	Microsoft ACPI-Compliant System
 (ISA) 0x000000B3 (179)	Microsoft ACPI-Compliant System
 (ISA) 0x000000B4 (180)	Microsoft ACPI-Compliant System
 (ISA) 0x000000B5 (181)	Microsoft ACPI-Compliant System
 (ISA) 0x000000B6 (182)	Microsoft ACPI-Compliant System
 (ISA) 0x000000B7 (183)	Microsoft ACPI-Compliant System
 (ISA) 0x000000B8 (184)	Microsoft ACPI-Compliant System
 (ISA) 0x000000B9 (185)	Microsoft ACPI-Compliant System
 (ISA) 0x000000BA (186)	Microsoft ACPI-Compliant System
 (ISA) 0x000000BB (187)	Microsoft ACPI-Compliant System
 (ISA) 0x000000BC (188)	Microsoft ACPI-Compliant System
 (ISA) 0x000000BD (189)	Microsoft ACPI-Compliant System
 (ISA) 0x000000BE (190)	Microsoft ACPI-Compliant System
 (ISA) 0x000000BF (191)	Microsoft ACPI-Compliant System
 (ISA) 0x00000100 (256)	Microsoft ACPI-Compliant System
 (ISA) 0x00000101 (257)	Microsoft ACPI-Compliant System
 (ISA) 0x00000102 (258)	Microsoft ACPI-Compliant System

 (ISA) 0x00000103 (259)	Microsoft ACPI-Compliant System
 (ISA) 0x00000104 (260)	Microsoft ACPI-Compliant System
 (ISA) 0x00000105 (261)	Microsoft ACPI-Compliant System
 (ISA) 0x00000106 (262)	Microsoft ACPI-Compliant System
 (ISA) 0x00000107 (263)	Microsoft ACPI-Compliant System
 (ISA) 0x00000108 (264)	Microsoft ACPI-Compliant System
 (ISA) 0x00000109 (265)	Microsoft ACPI-Compliant System
 (ISA) 0x0000010A (266)	Microsoft ACPI-Compliant System
 (ISA) 0x0000010B (267)	Microsoft ACPI-Compliant System
 (ISA) 0x0000010C (268)	Microsoft ACPI-Compliant System
 (ISA) 0x0000010D (269)	Microsoft ACPI-Compliant System
 (ISA) 0x0000010E (270)	Microsoft ACPI-Compliant System
 (ISA) 0x0000010F (271)	Microsoft ACPI-Compliant System
 (ISA) 0x00000110 (272)	Microsoft ACPI-Compliant System
 (ISA) 0x00000111 (273)	Microsoft ACPI-Compliant System
 (ISA) 0x00000112 (274)	Microsoft ACPI-Compliant System
 (ISA) 0x00000113 (275)	Microsoft ACPI-Compliant System
 (ISA) 0x00000114 (276)	Microsoft ACPI-Compliant System
 (ISA) 0x00000115 (277)	Microsoft ACPI-Compliant System
 (ISA) 0x00000116 (278)	Microsoft ACPI-Compliant System
 (ISA) 0x00000117 (279)	Microsoft ACPI-Compliant System
 (ISA) 0x00000118 (280)	Microsoft ACPI-Compliant System
 (ISA) 0x00000119 (281)	Microsoft ACPI-Compliant System
 (ISA) 0x0000011A (282)	Microsoft ACPI-Compliant System
 (ISA) 0x0000011B (283)	Microsoft ACPI-Compliant System
 (ISA) 0x0000011C (284)	Microsoft ACPI-Compliant System
 (ISA) 0x0000011D (285)	Microsoft ACPI-Compliant System
 (ISA) 0x0000011E (286)	Microsoft ACPI-Compliant System
 (ISA) 0x0000011F (287)	Microsoft ACPI-Compliant System
 (ISA) 0x00000120 (288)	Microsoft ACPI-Compliant System
 (ISA) 0x00000121 (289)	Microsoft ACPI-Compliant System
 (ISA) 0x00000122 (290)	Microsoft ACPI-Compliant System
 (ISA) 0x00000123 (291)	Microsoft ACPI-Compliant System
 (ISA) 0x00000124 (292)	Microsoft ACPI-Compliant System
 (ISA) 0x00000125 (293)	Microsoft ACPI-Compliant System
 (ISA) 0x00000126 (294)	Microsoft ACPI-Compliant System
 (ISA) 0x00000127 (295)	Microsoft ACPI-Compliant System
 (ISA) 0x00000128 (296)	Microsoft ACPI-Compliant System
 (ISA) 0x00000129 (297)	Microsoft ACPI-Compliant System
 (ISA) 0x0000012A (298)	Microsoft ACPI-Compliant System
 (ISA) 0x0000012B (299)	Microsoft ACPI-Compliant System
 (ISA) 0x0000012C (300)	Microsoft ACPI-Compliant System











































 (ISA) 0x0000012D (301)	Microsoft ACPI-Compliant System
 (ISA) 0x0000012E (302)	Microsoft ACPI-Compliant System
 (ISA) 0x0000012F (303)	Microsoft ACPI-Compliant System
 (ISA) 0x00000130 (304)	Microsoft ACPI-Compliant System
 (ISA) 0x00000131 (305)	Microsoft ACPI-Compliant System
 (ISA) 0x00000132 (306)	Microsoft ACPI-Compliant System
 (ISA) 0x00000133 (307)	Microsoft ACPI-Compliant System
 (ISA) 0x00000134 (308)	Microsoft ACPI-Compliant System
 (ISA) 0x00000135 (309)	Microsoft ACPI-Compliant System
 (ISA) 0x00000136 (310)	Microsoft ACPI-Compliant System
 (ISA) 0x00000137 (311)	Microsoft ACPI-Compliant System
 (ISA) 0x00000138 (312)	Microsoft ACPI-Compliant System
 (ISA) 0x00000139 (313)	Microsoft ACPI-Compliant System
 (ISA) 0x0000013A (314)	Microsoft ACPI-Compliant System
 (ISA) 0x0000013B (315)	Microsoft ACPI-Compliant System
 (ISA) 0x0000013C (316)	Microsoft ACPI-Compliant System
 (ISA) 0x0000013D (317)	Microsoft ACPI-Compliant System
 (ISA) 0x0000013E (318)	Microsoft ACPI-Compliant System
 (ISA) 0x0000013F (319)	Microsoft ACPI-Compliant System
 (ISA) 0x00000140 (320)	Microsoft ACPI-Compliant System
 (ISA) 0x00000141 (321)	Microsoft ACPI-Compliant System
 (ISA) 0x00000142 (322)	Microsoft ACPI-Compliant System
 (ISA) 0x00000143 (323)	Microsoft ACPI-Compliant System
 (ISA) 0x00000144 (324)	Microsoft ACPI-Compliant System
 (ISA) 0x00000145 (325)	Microsoft ACPI-Compliant System
 (ISA) 0x00000146 (326)	Microsoft ACPI-Compliant System
 (ISA) 0x00000147 (327)	Microsoft ACPI-Compliant System
 (ISA) 0x00000148 (328)	Microsoft ACPI-Compliant System
 (ISA) 0x00000149 (329)	Microsoft ACPI-Compliant System
 (ISA) 0x0000014A (330)	Microsoft ACPI-Compliant System
 (ISA) 0x0000014B (331)	Microsoft ACPI-Compliant System
 (ISA) 0x0000014C (332)	Microsoft ACPI-Compliant System
 (ISA) 0x0000014D (333)	Microsoft ACPI-Compliant System
 (ISA) 0x0000014E (334)	Microsoft ACPI-Compliant System
 (ISA) 0x0000014F (335)	Microsoft ACPI-Compliant System
 (ISA) 0x00000150 (336)	Microsoft ACPI-Compliant System
 (ISA) 0x00000151 (337)	Microsoft ACPI-Compliant System
 (ISA) 0x00000152 (338)	Microsoft ACPI-Compliant System
 (ISA) 0x00000153 (339)	Microsoft ACPI-Compliant System
 (ISA) 0x00000154 (340)	Microsoft ACPI-Compliant System
 (ISA) 0x00000155 (341)	Microsoft ACPI-Compliant System
 (ISA) 0x00000156 (342)	Microsoft ACPI-Compliant System





















































 (ISA) 0x00000157 (343)	Microsoft ACPI-Compliant System
 (ISA) 0x00000158 (344)	Microsoft ACPI-Compliant System
 (ISA) 0x00000159 (345)	Microsoft ACPI-Compliant System
 (ISA) 0x0000015A (346)	Microsoft ACPI-Compliant System
 (ISA) 0x0000015B (347)	Microsoft ACPI-Compliant System
 (ISA) 0x0000015C (348)	Microsoft ACPI-Compliant System
 (ISA) 0x0000015D (349)	Microsoft ACPI-Compliant System
 (ISA) 0x0000015E (350)	Microsoft ACPI-Compliant System
 (ISA) 0x0000015F (351)	Microsoft ACPI-Compliant System
 (ISA) 0x00000160 (352)	Microsoft ACPI-Compliant System
 (ISA) 0x00000161 (353)	Microsoft ACPI-Compliant System
 (ISA) 0x00000162 (354)	Microsoft ACPI-Compliant System
 (ISA) 0x00000163 (355)	Microsoft ACPI-Compliant System
 (ISA) 0x00000164 (356)	Microsoft ACPI-Compliant System
 (ISA) 0x00000165 (357)	Microsoft ACPI-Compliant System
 (ISA) 0x00000166 (358)	Microsoft ACPI-Compliant System
 (ISA) 0x00000167 (359)	Microsoft ACPI-Compliant System
 (ISA) 0x00000168 (360)	Microsoft ACPI-Compliant System
 (ISA) 0x00000169 (361)	Microsoft ACPI-Compliant System
 (ISA) 0x0000016A (362)	Microsoft ACPI-Compliant System
 (ISA) 0x0000016B (363)	Microsoft ACPI-Compliant System
 (ISA) 0x0000016C (364)	Microsoft ACPI-Compliant System
 (ISA) 0x0000016D (365)	Microsoft ACPI-Compliant System
 (ISA) 0x0000016E (366)	Microsoft ACPI-Compliant System
 (ISA) 0x0000016F (367)	Microsoft ACPI-Compliant System
 (ISA) 0x00000170 (368)	Microsoft ACPI-Compliant System
 (ISA) 0x00000171 (369)	Microsoft ACPI-Compliant System
 (ISA) 0x00000172 (370)	Microsoft ACPI-Compliant System
 (ISA) 0x00000173 (371)	Microsoft ACPI-Compliant System
 (ISA) 0x00000174 (372)	Microsoft ACPI-Compliant System
 (ISA) 0x00000175 (373)	Microsoft ACPI-Compliant System
 (ISA) 0x00000176 (374)	Microsoft ACPI-Compliant System
 (ISA) 0x00000177 (375)	Microsoft ACPI-Compliant System
 (ISA) 0x00000178 (376)	Microsoft ACPI-Compliant System
 (ISA) 0x00000179 (377)	Microsoft ACPI-Compliant System
 (ISA) 0x0000017A (378)	Microsoft ACPI-Compliant System
 (ISA) 0x0000017B (379)	Microsoft ACPI-Compliant System
 (ISA) 0x0000017C (380)	Microsoft ACPI-Compliant System
 (ISA) 0x0000017D (381)	Microsoft ACPI-Compliant System
 (ISA) 0x0000017E (382)	Microsoft ACPI-Compliant System
 (ISA) 0x0000017F (383)	Microsoft ACPI-Compliant System
 (ISA) 0x00000180 (384)	Microsoft ACPI-Compliant System

 (ISA) 0x00000181 (385)	Microsoft ACPI-Compliant System
 (ISA) 0x00000182 (386)	Microsoft ACPI-Compliant System
 (ISA) 0x00000183 (387)	Microsoft ACPI-Compliant System
 (ISA) 0x00000184 (388)	Microsoft ACPI-Compliant System
 (ISA) 0x00000185 (389)	Microsoft ACPI-Compliant System
 (ISA) 0x00000186 (390)	Microsoft ACPI-Compliant System
 (ISA) 0x00000187 (391)	Microsoft ACPI-Compliant System
 (ISA) 0x00000188 (392)	Microsoft ACPI-Compliant System
 (ISA) 0x00000189 (393)	Microsoft ACPI-Compliant System
 (ISA) 0x0000018A (394)	Microsoft ACPI-Compliant System
 (ISA) 0x0000018B (395)	Microsoft ACPI-Compliant System
 (ISA) 0x0000018C (396)	Microsoft ACPI-Compliant System
 (ISA) 0x0000018D (397)	Microsoft ACPI-Compliant System
 (ISA) 0x0000018E (398)	Microsoft ACPI-Compliant System
 (ISA) 0x0000018F (399)	Microsoft ACPI-Compliant System
 (ISA) 0x00000190 (400)	Microsoft ACPI-Compliant System
 (ISA) 0x00000191 (401)	Microsoft ACPI-Compliant System
 (ISA) 0x00000192 (402)	Microsoft ACPI-Compliant System
 (ISA) 0x00000193 (403)	Microsoft ACPI-Compliant System
 (ISA) 0x00000194 (404)	Microsoft ACPI-Compliant System
 (ISA) 0x00000195 (405)	Microsoft ACPI-Compliant System
 (ISA) 0x00000196 (406)	Microsoft ACPI-Compliant System
 (ISA) 0x00000197 (407)	Microsoft ACPI-Compliant System
 (ISA) 0x00000198 (408)	Microsoft ACPI-Compliant System
 (ISA) 0x00000199 (409)	Microsoft ACPI-Compliant System
 (ISA) 0x0000019A (410)	Microsoft ACPI-Compliant System
 (ISA) 0x0000019B (411)	Microsoft ACPI-Compliant System
 (ISA) 0x0000019C (412)	Microsoft ACPI-Compliant System
 (ISA) 0x0000019D (413)	Microsoft ACPI-Compliant System
 (ISA) 0x0000019E (414)	Microsoft ACPI-Compliant System
 (ISA) 0x0000019F (415)	Microsoft ACPI-Compliant System
 (ISA) 0x000001A0 (416)	Microsoft ACPI-Compliant System
 (ISA) 0x000001A1 (417)	Microsoft ACPI-Compliant System
 (ISA) 0x000001A2 (418)	Microsoft ACPI-Compliant System
 (ISA) 0x000001A3 (419)	Microsoft ACPI-Compliant System
 (ISA) 0x000001A4 (420)	Microsoft ACPI-Compliant System
 (ISA) 0x000001A5 (421)	Microsoft ACPI-Compliant System
 (ISA) 0x000001A6 (422)	Microsoft ACPI-Compliant System
 (ISA) 0x000001A7 (423)	Microsoft ACPI-Compliant System
 (ISA) 0x000001A8 (424)	Microsoft ACPI-Compliant System
 (ISA) 0x000001A9 (425)	Microsoft ACPI-Compliant System
 (ISA) 0x000001AA (426)	Microsoft ACPI-Compliant System



 (ISA) 0x000001AB (427)	Microsoft ACPI-Compliant System
 (ISA) 0x000001AC (428)	Microsoft ACPI-Compliant System
 (ISA) 0x000001AD (429)	Microsoft ACPI-Compliant System
 (ISA) 0x000001AE (430)	Microsoft ACPI-Compliant System
 (ISA) 0x000001AF (431)	Microsoft ACPI-Compliant System
 (ISA) 0x000001B0 (432)	Microsoft ACPI-Compliant System
 (ISA) 0x000001B1 (433)	Microsoft ACPI-Compliant System
 (ISA) 0x000001B2 (434)	Microsoft ACPI-Compliant System
 (ISA) 0x000001B3 (435)	Microsoft ACPI-Compliant System
 (ISA) 0x000001B4 (436)	Microsoft ACPI-Compliant System
 (ISA) 0x000001B5 (437)	Microsoft ACPI-Compliant System
 (ISA) 0x000001B6 (438)	Microsoft ACPI-Compliant System
 (ISA) 0x000001B7 (439)	Microsoft ACPI-Compliant System
 (ISA) 0x000001B8 (440)	Microsoft ACPI-Compliant System
 (ISA) 0x000001B9 (441)	Microsoft ACPI-Compliant System
 (ISA) 0x000001BA (442)	Microsoft ACPI-Compliant System
 (ISA) 0x000001BB (443)	Microsoft ACPI-Compliant System
 (ISA) 0x000001BC (444)	Microsoft ACPI-Compliant System
 (ISA) 0x000001BD (445)	Microsoft ACPI-Compliant System
 (ISA) 0x000001BE (446)	Microsoft ACPI-Compliant System
 (ISA) 0x000001BF (447)	Microsoft ACPI-Compliant System
 (ISA) 0x000001C0 (448)	Microsoft ACPI-Compliant System
 (ISA) 0x000001C1 (449)	Microsoft ACPI-Compliant System
 (ISA) 0x000001C2 (450)	Microsoft ACPI-Compliant System
 (ISA) 0x000001C3 (451)	Microsoft ACPI-Compliant System
 (ISA) 0x000001C4 (452)	Microsoft ACPI-Compliant System
 (ISA) 0x000001C5 (453)	Microsoft ACPI-Compliant System
 (ISA) 0x000001C6 (454)	Microsoft ACPI-Compliant System
 (ISA) 0x000001C7 (455)	Microsoft ACPI-Compliant System
 (ISA) 0x000001C8 (456)	Microsoft ACPI-Compliant System
 (ISA) 0x000001C9 (457)	Microsoft ACPI-Compliant System
 (ISA) 0x000001CA (458)	Microsoft ACPI-Compliant System
 (ISA) 0x000001CB (459)	Microsoft ACPI-Compliant System
 (ISA) 0x000001CC (460)	Microsoft ACPI-Compliant System
 (ISA) 0x000001CD (461)	Microsoft ACPI-Compliant System
 (ISA) 0x000001CE (462)	Microsoft ACPI-Compliant System
 (ISA) 0x000001CF (463)	Microsoft ACPI-Compliant System
 (ISA) 0x000001D0 (464)	Microsoft ACPI-Compliant System
 (ISA) 0x000001D1 (465)	Microsoft ACPI-Compliant System
 (ISA) 0x000001D2 (466)	Microsoft ACPI-Compliant System
 (ISA) 0x000001D3 (467)	Microsoft ACPI-Compliant System
 (ISA) 0x000001D4 (468)	Microsoft ACPI-Compliant System

 (ISA) 0x000001D5 (469)	Microsoft ACPI-Compliant System
 (ISA) 0x000001D6 (470)	Microsoft ACPI-Compliant System
 (ISA) 0x000001D7 (471)	Microsoft ACPI-Compliant System
 (ISA) 0x000001D8 (472)	Microsoft ACPI-Compliant System
 (ISA) 0x000001D9 (473)	Microsoft ACPI-Compliant System
 (ISA) 0x000001DA (474)	Microsoft ACPI-Compliant System
 (ISA) 0x000001DB (475)	Microsoft ACPI-Compliant System
 (ISA) 0x000001DC (476)	Microsoft ACPI-Compliant System
 (ISA) 0x000001DD (477)	Microsoft ACPI-Compliant System
 (ISA) 0x000001DE (478)	Microsoft ACPI-Compliant System
 (ISA) 0x000001DF (479)	Microsoft ACPI-Compliant System
 (ISA) 0x000001E0 (480)	Microsoft ACPI-Compliant System
 (ISA) 0x000001E1 (481)	Microsoft ACPI-Compliant System
 (ISA) 0x000001E2 (482)	Microsoft ACPI-Compliant System
 (ISA) 0x000001E3 (483)	Microsoft ACPI-Compliant System
 (ISA) 0x000001E4 (484)	Microsoft ACPI-Compliant System
 (ISA) 0x000001E5 (485)	Microsoft ACPI-Compliant System
 (ISA) 0x000001E6 (486)	Microsoft ACPI-Compliant System
 (ISA) 0x000001E7 (487)	Microsoft ACPI-Compliant System
 (ISA) 0x000001E8 (488)	Microsoft ACPI-Compliant System
 (ISA) 0x000001E9 (489)	Microsoft ACPI-Compliant System
 (ISA) 0x000001EA (490)	Microsoft ACPI-Compliant System
 (ISA) 0x000001EB (491)	Microsoft ACPI-Compliant System
 (ISA) 0x000001EC (492)	Microsoft ACPI-Compliant System
 (ISA) 0x000001ED (493)	Microsoft ACPI-Compliant System
 (ISA) 0x000001EE (494)	Microsoft ACPI-Compliant System
 (ISA) 0x000001EF (495)	Microsoft ACPI-Compliant System
 (ISA) 0x000001F0 (496)	Microsoft ACPI-Compliant System
 (ISA) 0x000001F1 (497)	Microsoft ACPI-Compliant System
 (ISA) 0x000001F2 (498)	Microsoft ACPI-Compliant System
 (ISA) 0x000001F3 (499)	Microsoft ACPI-Compliant System
 (ISA) 0x000001F4 (500)	Microsoft ACPI-Compliant System
 (ISA) 0x000001F5 (501)	Microsoft ACPI-Compliant System
 (ISA) 0x000001F6 (502)	Microsoft ACPI-Compliant System
 (ISA) 0x000001F7 (503)	Microsoft ACPI-Compliant System
 (ISA) 0x000001F8 (504)	Microsoft ACPI-Compliant System
 (ISA) 0x000001F9 (505)	Microsoft ACPI-Compliant System
 (ISA) 0x000001FA (506)	Microsoft ACPI-Compliant System
 (ISA) 0x000001FB (507)	Microsoft ACPI-Compliant System
 (ISA) 0x000001FC (508)	Microsoft ACPI-Compliant System
 (ISA) 0x000001FD (509)	Microsoft ACPI-Compliant System
 (ISA) 0x000001FE (510)	Microsoft ACPI-Compliant System

 (PCI) 0x0000000B (11)	Mobile 6th Generation Intel(R) Processor Family I/O Thermal subsystem - 9D31
 (PCI) 0x0000000B (11)	Mobile 6th Generation Intel(R) Processor Family I/O SMBUS - 9D23
 (PCI) 0x00000010 (16)	High Definition Audio Controller
 (PCI) 0x00000010 (16)	Standard SATA AHCI Controller
 (PCI) 0xFFFFFFFFB (-5)	Intel(R) Management Engine Interface
 (PCI) 0xFFFFFFFFC (-4)	Intel(R) USB 3.0 eXtensible Host Controller - 0100 (Microsoft)
 (PCI) 0xFFFFFFFFD (-3)	Intel(R) HD Graphics 510
 (PCI) 0xFFFFFFFFE (-2)	Intel(R) Ethernet Connection I219-LM

# Appendix C

---

Programming Digital I/O

## C.1 Digital I/O Programming

---

The COM-KBUC6 utilizes an AAEON chipset as its Digital I/O controller.

Below are the procedures to complete its configuration, which you can use to develop a customized program to fit your application.

## C.2 Digital I/O Register

---

**Table 1 : Embedded BRAM relative register table**

	Default Value	Note
Index	0x284(Note1)	BRAM Index Register
Data	0x285(Note2)	BRAM Data Register
Logical Device Number	0xA2(Note3)	Watch dog Logical Device Number
IO Direction Function and Device Number	0x00(Note4)	DIO Input/Output Function/Device Number
IO Vaule/Status Function and Device Number	0x01(Note5)	DIO Output Data Function/Device Number

## C.2 Digital I/O Sample Program

```
*****
// Embedded BRAM relative definition (Please reference to Table 1)
#define byte EcBRAMIndex //This parameter is represented from Note1
#define byte EcBRAMData //This parameter is represented from Note2
#define byte BRAMLDNReg //This parameter is represented from Note3
#define byte BRAMFnData0Reg //This parameter is represented from Note4
#define byte BRAMFnData1Reg //This parameter is represented from Note5
#define void EcBRAMWriteByte(byte Offset, byte Value);
#define byte EcBRAMReadByte(byte Offset);
#define void IOWriteByte(byte Offset, byte Value);
#define byte IOReadByte(byte Offset);
// Digital Input Status relative definition (Please reference to Table 2)
#define byte DIO0ToDIO7Reg // This parameter is represented from Note6
#define byte DIO0Bit // This parameter is represented from Note7
#define byte DIO1Bit // This parameter is represented from Note8
#define byte DIO2Bit // This parameter is represented from Note9
#define byte DIO3Bit // This parameter is represented from Note10
#define byte DIO4Bit // This parameter is represented from Note11
#define byte DIO5Bit // This parameter is represented from Note12
#define byte DIO6Bit // This parameter is represented from Note13
#define byte DIO7Bit // This parameter is represented from Note14
#define byte DIO0Val // This parameter is represented from Note15
#define byte DIO1Val // This parameter is represented from Note16
#define byte DIO2Val // This parameter is represented from Note17
#define byte DIO3Val // This parameter is represented from Note18
#define byte DIO4Val // This parameter is represented from Note19
#define byte DIO5Val // This parameter is represented from Note20
#define byte DIO6Val // This parameter is represented from Note21
#define byte DIO7Val // This parameter is represented from Note22
*****
```

```
*****  
VOID Main()  
    Boolean PinStatus ;  
  
    // Procedure : AaeonReadPinStatus  
    // Input :  
    //     Example, Read Digital I/O Pin 3 status  
    // Output :  
    //     InputStatus :  
    //         0: Digital I/O Pin level is low  
    //         1: Digital I/O Pin level is High  
    PinStatus = AaeonReadPinStatus(DIO0ToDIO7Reg, DIO3Bit);  
  
    // Procedure : AaeonSetOutputLevel  
    // Input :  
    //     Example, Set Digital I/O Pin 6 level  
    AaeonSetOutputLevel(DIO0ToDIO7Reg, DIO6Bit, DIO6Val);  
}
```

```
*****
Boolean AaeonReadPinStatus(byte OptionReg, byte BitNum){
    Byte TempByte;

    TempByte = ECBRAMReadByte(BRAMFnData1Reg, OptionReg);
    If (TempByte & BitNum == 0)
        Return 0;
    Return 1;
}
VOID AaeonSetOutputLevel(byte OptionReg, byte BitNum, byte Value){
    Byte TempByte;

    TempByte = ECBRAMReadByte(BRAMFnData1Reg, OptionReg);
    TempByte |= (Value << BitNum);
    ECBRAMWriteByte(OptionReg, BitNum, Value);
}
*****
```



```

*****
VOID ECBRAMWriteByte(byte OPReg, byte OPBit, byte Value){
    IOWriteByte(EcBRAMIndex, 0x10);
    IOWriteByte(EcBRAMData, BRAMLDNReg);
    IOWriteByte(EcBRAMIndex, 0x11);
    IOWriteByte(EcBRAMData, BRAMFnDataReg);

    IOWriteByte(EcBRAMIndex, 0x13 + OPReg);
    IOWriteByte(EcBRAMData, Value);

    IOWriteByte(EcBRAMIndex, 0x12);
    IOWriteByte(EcBRAMData, 0x30);           //Write start
}

Byte ECBRAMReadByte(byte FnDataReg, byte OPReg){
    IOWriteByte(EcBRAMIndex, 0x10);
    IOWriteByte(EcBRAMData, BRAMLDNReg);
    IOWriteByte(EcBRAMIndex, 0x11);
    IOWriteByte(EcBRAMData, FnDataReg);

    IOWriteByte(EcBRAMIndex, 0x12);
    IOWriteByte(EcBRAMData, 0x10);         //Read start

    IOWriteByte(EcBRAMIndex, 0x13 + OPReg);
    Return      IOReadByte(EcBRAMData, Value);
}
*****

```

# Appendix D

---

Notes for Users

## D.1 Notes for Users

---

Please observe the following items to ensure optimal performance:

1. Always use a new SSD with the latest firmware and SATA Gen3 cable for optimal performance and compatibility.
2. With the EHCI controller no longer available on the 6<sup>th</sup> Gen Intel® Core™ platforms, it is recommended to install Windows 7 through a SATA bus, eg SATA DVD ROM, or refer to <https://downloadcenter.intel.com/download/25476/Windows-7-USB-3-0-Creator-Utility> to create a USB installer.
3. Per Platform and COMe Spec, this product supports Five PCIe[x1] devices in default. If other PCIe device q'ty or grouping required, please contact your AAEON contact for support.
4. After booting to the OS, the board's display priority will be taken over by the graphics driver. In case when LVDS output is not needed, please disable LVDS in BIOS to prevent the driver from automatically setting LVDS as the output device.
5. For extended temperature SKU, it tested under AAEON's condition such as using AAEON thermal solution, tested under UEFI mode, etc.
6. The Kaby Lake platform (KBU) supports Microsoft Windows 10 64-bit version only.