

COM-SKHB6

COM Express Module

User's Manual 3rd Ed

Copyright Notice

This document is copyrighted, 2019. All rights are reserved. The original manufacturer reserves the right to make improvements to the products described in this manual at any time without notice.

No part of this manual may be reproduced, copied, translated, or transmitted in any form or by any means without the prior written permission of the original manufacturer. Information provided in this manual is intended to be accurate and reliable. However, the original manufacturer assumes no responsibility for its use, or for any infringements upon the rights of third parties that may result from its use.

The material in this document is for product information only and is subject to change without notice. While reasonable efforts have been made in the preparation of this document to assure its accuracy, AAEMON assumes no liabilities resulting from errors or omissions in this document, or from the use of the information contained herein.

AAEMON reserves the right to make changes in the product design without notice to its users.

Acknowledgement

All other products' name or trademarks are properties of their respective owners.

- Microsoft Windows is a registered trademark of Microsoft Corp.
- Intel, Pentium, Celeron, and Xeon are registered trademarks of Intel Corporation
- Core, Atom are trademarks of Intel Corporation
- ITE is a trademark of Integrated Technology Express, Inc.
- IBM, PC/AT, PS/2, and VGA are trademarks of International Business Machines Corporation.

All other product names or trademarks are properties of their respective owners.

Packing List

Before setting up your product, please make sure the following items have been shipped:

Item	Quantity
● COM-SKHB6	1
● M2.5 screws	5

If any of these items are missing or damaged, please contact your distributor or sales representative immediately.

About this Document

This User's Manual contains all the essential information, such as detailed descriptions and explanations on the product's hardware and software features (if any), its specifications, dimensions, jumper/connector settings/definitions, and driver installation instructions (if any), to facilitate users in setting up their product.

Users may refer to the AAEON.com for the latest version of this document.

Safety Precautions

Please read the following safety instructions carefully. It is advised that you keep this manual for future references

1. All cautions and warnings on the device should be noted.
2. Make sure the power source matches the power rating of the device.
3. Position the power cord so that people cannot step on it. Do not place anything over the power cord.
4. Always completely disconnect the power before working on the system's hardware.
5. No connections should be made when the system is powered as a sudden rush of power may damage sensitive electronic components.
6. If the device is not to be used for a long time, disconnect it from the power supply to avoid damage by transient over-voltage.
7. Always disconnect this device from any AC supply before cleaning.
8. While cleaning, use a damp cloth instead of liquid or spray detergents.
9. Make sure the device is installed near a power outlet and is easily accessible.
10. Keep this device away from humidity.
11. Place the device on a solid surface during installation to prevent falls
12. Do not cover the openings on the device to ensure optimal heat dissipation.
13. Watch out for high temperatures when the system is running.
14. Do not touch the heat sink or heat spreader when the system is running
15. Never pour any liquid into the openings. This could cause fire or electric shock.
16. As most electronic components are sensitive to static electrical charge, be sure to ground yourself to prevent static charge when installing the internal components. Use a grounding wrist strap and contain all electronic components in any static-shielded containers.

17. If any of the following situations arises, please contact our service personnel:
 - i. Damaged power cord or plug
 - ii. Liquid intrusion to the device
 - iii. Exposure to moisture
 - iv. Device is not working as expected or in a manner as described in this manual
 - v. The device is dropped or damaged
 - vi. Any obvious signs of damage displayed on the device
18. **DO NOT LEAVE THIS DEVICE IN AN UNCONTROLLED ENVIRONMENT WITH TEMPERATURES BEYOND THE DEVICE'S PERMITTED STORAGE TEMPERATURES (SEE CHAPTER 1) TO PREVENT DAMAGE.**

Warning!



This device complies with Part 15 FCC Rules. Operation is subject to the following two conditions: (1) this device may not cause harmful interference, and (2) this device must accept any interference received including interference that may cause undesired operation.

Caution:

There is a danger of explosion if the battery is incorrectly replaced. Replace only with the same or equivalent type recommended by the manufacturer. Dispose of used batteries according to the manufacturer's instructions and your local government's recycling or disposal directives.

Attention:

Il y a un risque d'explosion si la batterie est remplacée de façon incorrecte. Ne la remplacer qu'avec le même modèle ou équivalent recommandé par le constructeur. Recycler les batteries usées en accord avec les instructions du fabricant et les directives gouvernementales de recyclage.

China RoHS Requirements (CN)

产品中有毒有害物质或元素名称及含量

AAEON Main Board/ Daughter Board/ Backplane

部件名称	有毒有害物质或元素					
	铅 (Pb)	汞 (Hg)	镉 (Cd)	六价铬 (Cr(VI))	多溴联苯 (PBB)	多溴二苯醚 (PBDE)
印刷电路板 及其电子组件	○	○	○	○	○	○
外部信号 连接器及线材	○	○	○	○	○	○
<p>○: 表示该有毒有害物质在该部件所有均质材料中的含量均在 SJ/T 11363-2006 标准规定的限量要求以下。</p> <p>X: 表示该有毒有害物质至少在该部件的某一均质材料中的含量超出 SJ/T 11363-2006 标准规定的限量要求。</p> <p>备注: 此产品所标示之环保使用期限, 系指在一般正常使用状况下。</p>						

China RoHS Requirement (EN)

Poisonous or Hazardous Substances or Elements in Products

AAEON Main Board/ Daughter Board/ Backplane

Component	Poisonous or Hazardous Substances or Elements					
	Lead (Pb)	Mercury (Hg)	Cadmium (Cd)	Hexavalent Chromium (Cr(VI))	Polybrominated Biphenyls (PBB)	Polybrominated Diphenyl Ethers (PBDE)
PCB & Other Components	○	○	○	○	○	○
Wires & Connectors for External Connections	○	○	○	○	○	○
<p>O: The quantity of poisonous or hazardous substances or elements found in each of the component's parts is below the SJ/T 11363-2006-stipulated requirement.</p> <p>X: The quantity of poisonous or hazardous substances or elements found in at least one of the component's parts is beyond the SJ/T 11363-2006-stipulated requirement.</p> <p>Note: The Environment Friendly Use Period as labeled on this product is applicable under normal usage only</p>						

Table of Contents

Chapter 1 - Product Specifications	1
1.1 Specifications	2
Chapter 2 – Hardware Information	4
2.1 Dimensions, Jumpers and Connectors	5
2.2 List of Jumpers	7
2.2.1 AT/ATX Switch (SW1).....	7
2.3 List of Connectors.....	8
2.3.1 COM Express Row C/D Connector (CN1)	9
2.3.2 COM Express Row A/B Connector (CN4).....	13
Chapter 3 - AMI BIOS Setup	17
3.1 System Test and Initialization	18
3.2 AMI BIOS Setup	19
3.3 Setup submenu: Main	20
3.4 Setup submenu: Advanced	21
3.4.1 Advanced: CPU Configuration	22
3.4.2 Advanced: Trusted Computing	23
3.4.3 Advanced: SIO Configuration.....	25
3.4.3.1 SIO Configuration: Serial Port X Configuration	26
3.4.4 Advanced: On-Module H/W Monitor	27
3.4.4.1 On-Module H/W Monitor: CPU Smart Fan Mode Configuration.....	28
3.4.5 Advanced: USB Configuration.....	30
3.4.6 Advanced: Digital IO Port Configuration	31
3.4.7 Advanced: Power Management	32
3.5 Setup submenu: Chipset.....	34
3.5.1 Chipset: System Agent (SA) Configuration.....	35

3.5.1.1	System Agent (SA) Configuration: Graphics Configuration.....	36
3.5.1.2	Graphics Configuration: LVDS Panel Configuration....	37
3.5.2	Chipset: PCH-IO Configuration.....	39
3.6	Setup submenu: Security	40
3.7	Setup submenu: Boot.....	41
3.8	Setup submenu: Save & Exit	42
Chapter 4	– Drivers Installation.....	43
4.1	Driver Download/Installation	44
Appendix A	- Watchdog Timer Programming.....	46
A.1	Watchdog Timer Initial Program	47
Appendix B	- I/O Information	52
B.1	I/O Address Map	53
B.2	Memory Address Map	56
B.3	IRQ Mapping Chart.....	58
Appendix C	– Programming Digital I/O.....	60
C.1	Digital I/O Register.....	61
C.2	Digital I/O Sample Program.....	62
Appendix D	–Notes for Users	66
D.1	Notes for Users	67

Chapter 1

Product Specifications

1.1 Specifications

System

Form Factor	COM Express Basic Size
CPU	i7-6820EQ 4c/2.7 GHz, i3-6100E 2c/2.7 GHz, XEON E3-1505M-V6
CPU Frequency	Up to XEON E3-1505MV6 4C/3.0 GHz
Chipset	PCH QM170 or CM236 (by sku)/CM238
Memory Type	DDR4, SODIMM x 2, ECC Supports with CM236/CM238 sku only, up to 2133
Max. Memory Capacity	32GB
BIOS	AMI BIOS, Legacy Free
Wake on LAN	Yes
Watchdog Timer	255 levels
Power Requirement	Standard: +12V
Power Supply Type	AT/ATX Selection
Power Consumption (Typical)	Intel i7-6820EQ 2.8GHz, DDR4 16GB 3.08A@12V
Dimension (L x W)	4.92" x 3.75" (125mm x 95mm)
Operating Temperature	32°F ~ 140°F (0°C ~ 60°C)
Storage Temperature	-4°F ~ 158°F (-20°C ~ 70°C)
Operating Humidity	10% ~90% relative humidity, non-condensing

System

MTBF (Hours)	80,000
Certification	CE/FCC Class A

Display

VGA/LCD Controller	Onboard 6th Gen Intel® Core™ H-series Processor, GT2
Video Output	VGA, LVDS/eDP, DDI x2

I/O

Ethernet	Intel® I219, Gigabit Ethernet
Audio	HD Audio
USB Port	USB 2.0 x 8, USB 3.0 x 4
Serial Port	2-Wire UART (Tx/Rx) x 2
HDD Interface	SATA x 4
Onboard SSD	—
Expansion Slot	PCIe[x16] x 1, PCIe[x1] x 8, I2C, LPC, SMBus
GPIO	GPIO 8-bit
TPM	Optional

Chapter 2

Hardware Information

2.1 Dimensions, Jumpers and Connectors

Component Side

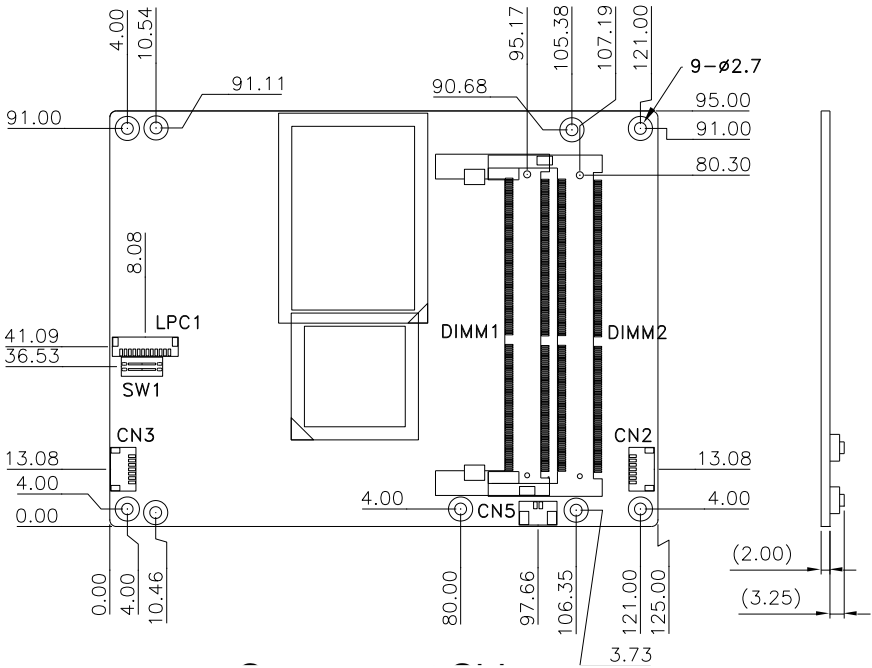

Solder Side

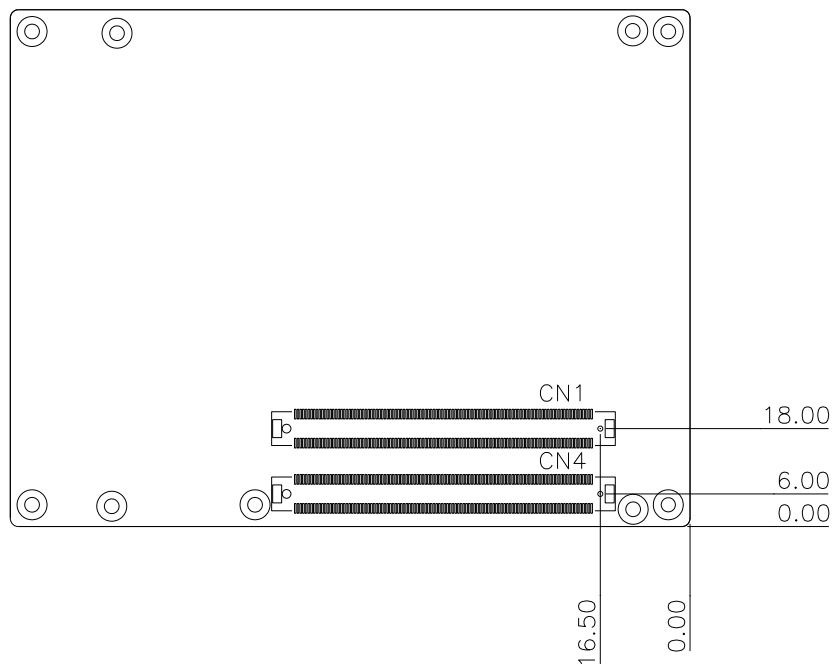

With Heat spreader

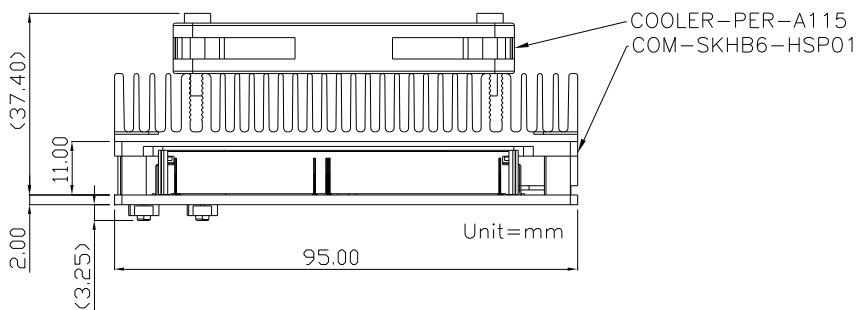

*PER-A115 to be renamed to COM-FAN01 in Q3 2016

2.2 List of Jumpers

Please refer to the table below for all of the board's jumpers that you can configure for your application

Label	Function
SW1	Auto power button and clear CMOS selection

2.2.1 AT/ATX Switch (SW1)

	ON	OFF
1	Enable auto power button	Disable auto power button
2	Clear CMOS	Normal (default)

2.3 List of Connectors

Please refer to the table below for all of the board's jumpers that you can configure for your application

Label	Function
CN1	Express ROW C/D Connector
CN2	BIOS SPI Flash Programming Connector
CN3	EC SPI Flash Programming Connector
CN4	Express ROW A/B Connector
CN5	RTC Battery Connector
DIMM1	SO-DIMMCOM
DIMM2	SO-DIMMCOM
LPC1	LPC debug card Connector

2.3.1 COM Express Row C/D Connector (CN1)

Row C		Row D	
Pin	Signal	Pin	Signal
C1	GND (FIXED)	D1	GND (FIXED)
C2	GND (FIXED)	D2	GND (FIXED)
C3	USB_SSRX0-	D3	USB_SSTX0-
C4	USB_SSRX0+	D4	USB_SSTX0+
C5	GND (FIXED)	D5	GND (FIXED)
C6	USB_SSRX1-	D6	USB_SSTX1-
C7	USB_SSRX1+	D7	USB_SSTX1+
C8	GND (FIXED)	D8	GND (FIXED)
C9	USB_SSRX2-	D9	USB_SSTX2-
C10	USB_SSRX2+	D10	USB_SSTX2+
C11	GND (FIXED)	D11	GND (FIXED)
C12	USB_SSRX3-	D12	USB_SSTX3-
C13	USB_SSRX3+	D13	USB_SSTX3+
C14	GND (FIXED)	D14	GND (FIXED)
C15	DDI1_PAIR6+(NC)	D15	DDI1_CTRLCLK_AUX+
C16	DDI1_PAIR6-(NC)	D16	DDI1_CTRLDATA_AUX-
C17	RSVD	D17	RSVD
C18	RSVD	D18	RSVD
C19	PCIE_RX6+	D19	PCIE_TX6+
C20	PCIE_RX6-	D20	PCIE_TX6-
C21	GND (FIXED)	D21	GND (FIXED)
C22	PCIE_RX7+	D22	PCIE_TX7+
C23	PCIE_RX7-	D23	PCIE_TX7-
C24	DDI1_HPD	D24	RSVD

C25	DDI1_PAIR4+(NC)	D25	RSVD
C26	DDI1_PAIR4-(NC)	D26	DDI1_PAIR0+
C27	RSVD	D27	DDI1_PAIR0-
C28	RSVD	D28	RSVD
C29	DDI1_PAIR5+(NC)	D29	DDI1_PAIR1+
C30	DDI1_PAIR5-(NC)	D30	DDI1_PAIR1-
C31	GND (FIXED)	D31	GND (FIXED)
C32	DDI2_CTRLCLK_AUX+	D32	DDI1_PAIR2+
C33	DDI2_CTRLDATA_AUX-	D33	DDI1_PAIR2-
C34	DDI2_DDC_AUX_SEL	D34	DDI1_DDC_AUX_SEL
C35	RSVD	D35	RSVD
C36	DDI3_CTRLCLK_AUX+	D36	DDI1_PAIR3+
C37	DDI3_CTRLDATA_AUX-	D37	DDI1_PAIR3-
C38	DDI3_DDC_AUX_SEL	D38	RSVD
C39	DDI3_PAIR0+	D39	DDI2_PAIR0+
C40	DDI3_PAIR0-	D40	DDI2_PAIR0-
C41	GND (FIXED)	D41	GND (FIXED)
C42	DDI3_PAIR1+	D42	DDI2_PAIR1+
C43	DDI3_PAIR1-	D43	DDI2_PAIR1-
C44	DDI3_HPD	D44	DDI2_HPD
C45	RSVD	D45	RSVD
C46	DDI3_PAIR2+	D46	DDI2_PAIR2+
C47	DDI3_PAIR2-	D47	DDI2_PAIR2-
C48	RSVD	D48	RSVD
C49	DDI3_PAIR3+	D49	DDI2_PAIR3+
C50	DDI3_PAIR3-	D50	DDI2_PAIR3-
C51	GND (FIXED)	D51	GND (FIXED)
C52	PEG_RX0+	D52	PEG_TX0+
C53	PEG_RX0-	D53	PEG_TX0-

C54	TYPE0#(NC)	D54	PEG_LAN_RV#
C55	PEG_RX1+	D55	PEG_TX1+
C56	PEG_RX1-	D56	PEG_TX1-
C57	TYPE1#(NC)	D57	TYPE2#(GND)
C58	PEG_RX2+	D58	PEG_TX2+
C59	PEG_RX2-	D59	PEG_TX2-
C60	GND (FIXED)	D60	GND (FIXED)
C61	PEG_RX3+	D61	PEG_TX3+
C62	PEG_RX3-	D62	PEG_TX3-
C63	RSVD	D63	RSVD
C64	RSVD	D64	RSVD
C65	PEG_RX4+	D65	PEG_TX4+
C66	PEG_RX4-	D66	PEG_TX4-
C67	RSVD	D67	GND (FIXED)
C68	PEG_RX5+	D68	PEG_TX5+
C69	PEG_RX5-	D69	PEG_TX5-
C70	GND (FIXED)	D70	GND (FIXED)
C71	PEG_RX6+	D71	PEG_TX6+
C72	PEG_RX6-	D72	PEG_TX6-
C73	GND (FIXED)	D73	GND (FIXED)
C74	PEG_RX7+	D74	PEG_TX7+
C75	PEG_RX7-	D75	PEG_TX7-
C76	GND (FIXED)	D76	GND (FIXED)
C77	RSVD	D77	RSVD
C78	PEG_RX8+	D78	PEG_TX8+
C79	PEG_RX8-	D79	PEG_TX8-
C80	GND (FIXED)	D80	GND (FIXED)
C81	PEG_RX9+	D81	PEG_TX9+
C82	PEG_RX9-	D82	PEG_TX9-

C83	RSVD	D83	RSVD
C84	GND (FIXED)	D84	GND (FIXED)
C85	PEG_RX10+	D85	PEG_TX10+
C86	PEG_RX10-	D86	PEG_TX10-
C87	GND (FIXED)	D87	GND (FIXED)
C88	PEG_RX11+	D88	PEG_TX11+
C89	PEG_RX11-	D89	PEG_TX11-
C90	GND (FIXED)	D90	GND (FIXED)
C91	PEG_RX12+	D91	PEG_TX12+
C92	PEG_RX12-	D92	PEG_TX12-
C93	GND	D93	GND
C94	PEG_RX13+	D94	PEG_TX13+
C95	PEG_RX13-	D95	PEG_TX13-
C96	GND (FIXED)	D96	GND (FIXED)
C97	RSVD	D97	RSVD
C98	PEG_RX14+	D98	PEG_TX14+
C99	PEG_RX14-	D99	PEG_TX14-
C100	GND (FIXED)	D100	GND (FIXED)
C101	PEG_RX15+	D101	PEG_TX15+
C102	PEG_RX15-	D102	PEG_TX15-
C103	GND (FIXED)	D103	GND
C104	VCC_12V	D104	VCC_12V
C105	VCC_12V	D105	VCC_12V
C106	VCC_12V	D106	VCC_12V
C107	VCC_12V	D107	VCC_12V
C108	VCC_12V	D108	VCC_12V
C109	VCC_12V	D109	VCC_12V
C110	GND (FIXED)	D110	GND (FIXED)

2.3.2 COM Express Row A/B Connector (CN4)

Row A		Row B	
Pin	Signal	Pin	Signal
A1	GND (FIXED)	B1	GND (FIXED)
A2	GBE0_MDI3-	B2	GBE0_ACT#
A3	GBE0_MDI3+	B3	LPC_FRAME#
A4	GBE0_LINK100#	B4	LPC_AD0
A5	GBE0_LINK1000#	B5	LPC_AD1
A6	GBE0_MDI2-	B6	LPC_AD2
A7	GBE0_MDI2+	B7	LPC_AD3
A8	GBE0_LINK	B8	LPC_DRQ0#(NC)
A9	GBE0_MDI1-	B9	LPC_DRQ1#(NC)
A10	GBE0_MDI1+	B10	LPC_CLK
A11	GND (FIXED)	B11	GND (FIXED)
A12	GBE0_MDI0-	B12	PWRBTN#
A13	GBE0_MDI0+	B13	SMB_CK
A14	GBE0_CTREF	B14	SMB_DAT
A15	SUS_S3#	B15	SMB_ALERT#
A16	SATA0_TX+	B16	SATA1_TX+
A17	SATA0_TX-	B17	SATA1_TX-
A18	SUS_S4#	B18	SUS_STAT#
A19	SATA0_RX+	B19	SATA1_RX+
A20	SATA0_RX-	B20	SATA1_RX-
A21	GND (FIXED)	B21	GND (FIXED)
A22	SATA2_TX+	B22	SATA3_TX+
A23	SATA2_TX-	B23	SATA3_TX-
A24	SUS_S5#	B24	PWR_OK

A25	SATA2_RX+	B25	SATA3_RX+
A26	SATA2_RX-	B26	SATA3_RX-
A27	BATLOW#	B27	WDT
A28	ATA_ACT#	B28	HDA_SDIN2(NC)
A29	HDA_SYNC	B29	HDA_SDIN1
A30	HDA_RST#	B30	HDA_SDIN0
A31	GND (FIXED)	B31	GND (FIXED)
A32	HDA_BITCLK	B32	SPKR
A33	HDA_SDOOUT	B33	I2C_CK
A34	BIOS_DIS0#	B34	I2C_DAT
A35	THRMTRIP#	B35	THRM#
A36	USB6-	B36	USB7-
A37	USB6+	B37	USB7+
A38	USB_6_7_OC#	B38	USB_4_5_OC#
A39	USB4-	B39	USB5-
A40	USB4+	B40	USB5+
A41	GND (FIXED)	B41	GND (FIXED)
A42	USB2-	B42	USB3-
A43	USB2+	B43	USB3+
A44	USB_2_3_OC#	B44	USB_0_1_OC#
A45	USB0-	B45	USB1-
A46	USB0+	B46	USB1+
A47	VCC_RTC	B47	EXCD1_PERST#
A48	EXCD0_PERST#	B48	EXCD1_CPPE#
A49	EXCD0_CPPE#	B49	SYS_RESET#
A50	LPC_SERIRQ	B50	CB_RESET#
A51	GND (FIXED)	B51	GND (FIXED)
A52	PCIE_TX5+	B52	PCIE_RX5+
A53	PCIE_TX5-	B53	PCIE_RX5-

A54	GPI0	B54	GPO1
A55	PCIE_TX4+	B55	PCIE_RX4+
A56	PCIE_TX4-	B56	PCIE_RX4-
A57	GND	B57	GPO2
A58	PCIE_TX3+	B58	PCIE_RX3+
A59	PCIE_TX3-	B59	PCIE_RX3-
A60	GND (FIXED)	B60	GND (FIXED)
A61	PCIE_TX2+	B61	PCIE_RX2+
A62	PCIE_TX2-	B62	PCIE_RX2-
A63	GPI1	B63	GPO3
A64	PCIE_TX1+	B64	PCIE_RX1+
A65	PCIE_TX1-	B65	PCIE_RX1-
A66	GND	B66	WAKE0#
A67	GPI2	B67	WAKE1#
A68	PCIE_TX0+	B68	PCIE_RX0+
A69	PCIE_TX0-	B69	PCIE_RX0-
A70	GND (FIXED)	B70	GND (FIXED)
A71	LVDS_A0+	B71	LVDS_B0+
A72	LVDS_A0-	B72	LVDS_B0-
A73	LVDS_A1+	B73	LVDS_B1+
A74	LVDS_A1-	B74	LVDS_B1-
A75	LVDS_A2+	B75	LVDS_B2+
A76	LVDS_A2-	B76	LVDS_B2-
A77	LVDS_VDD_EN	B77	LVDS_B3+
A78	LVDS_A3+	B78	LVDS_B3-
A79	LVDS_A3-	B79	LVDS_BKLT_EN
A80	GND (FIXED)	B80	GND (FIXED)
A81	LVDS_A_CK+	B81	LVDS_B_CK+
A82	LVDS_A_CK-	B82	LVDS_B_CK-

A83	LVDS_I2C_CK	B83	LVDS_BKLT_CTRL
A84	LVDS_I2C_DAT	B84	VCC_5V_SBY
A85	GPI3	B85	VCC_5V_SBY
A86	RSVD	B86	VCC_5V_SBY
A87	RSVD	B87	VCC_5V_SBY
A88	PCIE0_CK_REF+	B88	BISO_DIS1#
A89	PCIE0_CK_REF-	B89	VGA_RED
A90	GND (FIXED)	B90	GND (FIXED)
A91	SPI_POWER	B91	VGA_GRN
A92	SPI_MISO	B92	VGA_BLU
A93	GPO0	B93	VGA_HSYNC
A94	SPI_CLK	B94	VGA_VSYNC
A95	SPI_MOSI	B95	VGA_I2C_CK
A96	GND	B96	VGA_I2C_DAT
A97	TYPE10#(NC)	B97	SPI_CS#
A98	TX0	B98	RSVD
A99	RX0	B99	RSVD
A100	GND (FIXED)	B100	GND (FIXED)
A101	TX1	B101	FAN_PWM
A102	RX1	B102	FAN_TACH_IN
A103	RSVD	B103	SLEEP#
A104	VCC_12V	B104	VCC_12V
A105	VCC_12V	B105	VCC_12V
A106	VCC_12V	B106	VCC_12V
A107	VCC_12V	B107	VCC_12V
A108	VCC_12V	B108	VCC_12V
A109	VCC_12V	B109	VCC_12V
A110	GND (FIXED)	B110	GND (FIXED)

Chapter 3

AMI BIOS Setup

3.1 System Test and Initialization

The board uses certain routines to perform testing and initialization. If an error, fatal or non-fatal, is encountered, a few short beeps or an error message will be outputted. The board can usually continue the boot up sequence with non-fatal errors.

The system configuration verification routines check the current system configuration against the values stored in the CMOS memory. If they do not match, an error message will be outputted, in which case you will need to run the BIOS setup program to set the configuration information in memory.

There are three situations in which you will need to change the CMOS settings:

- You are starting your system for the first time
- You have changed your system's hardware
- The CMOS memory has lost power and the configuration information is erased

The system's CMOS memory uses a backup battery for data retention, which is to be replaced once emptied.

3.2 AMI BIOS Setup

The AMI BIOS ROM has a pre-installed Setup program that allows users to modify basic system configurations, which is stored in the battery-backed CMOS RAM and BIOS NVRAM so that the information is retained when the power is turned off.

To enter BIOS Setup, press or <F2> immediately while your computer is powering up.

The function for each interface can be found below.

Main – Date and time can be set here. Press <Tab> to switch between date elements

Advanced – Enable/ Disable boot option for legacy network devices

Chipset – For hosting bridge parameters

Boot – Enable/ Disable quiet Boot Option

Security – The setup administrator password can be set here

Save & Exit – Save your changes and exit the program

3.3 Setup submenu: Main

Press **Delete** to enter Setup

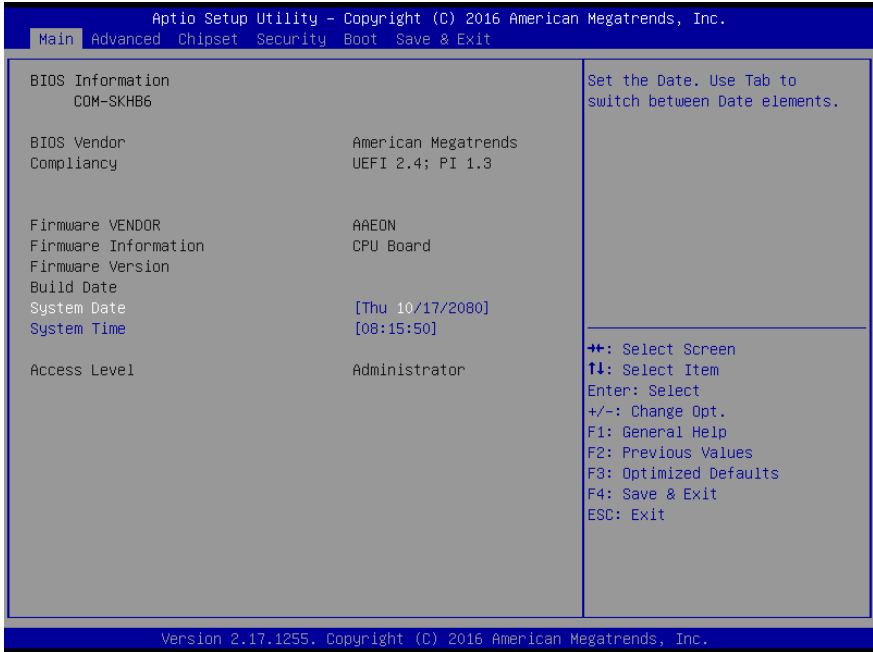

3.4 Setup submenu: Advanced

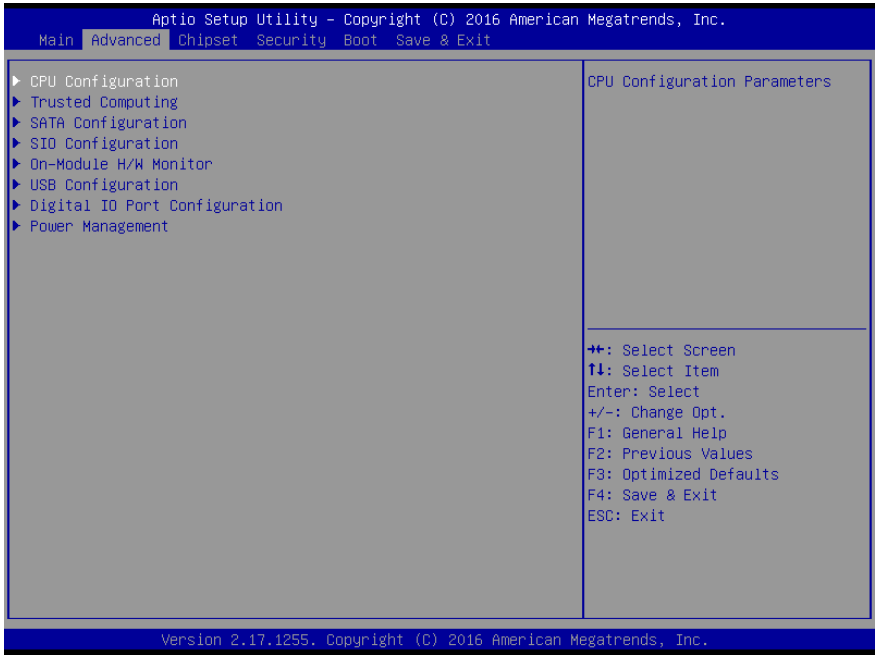

3.4.1 Advanced: CPU Configuration

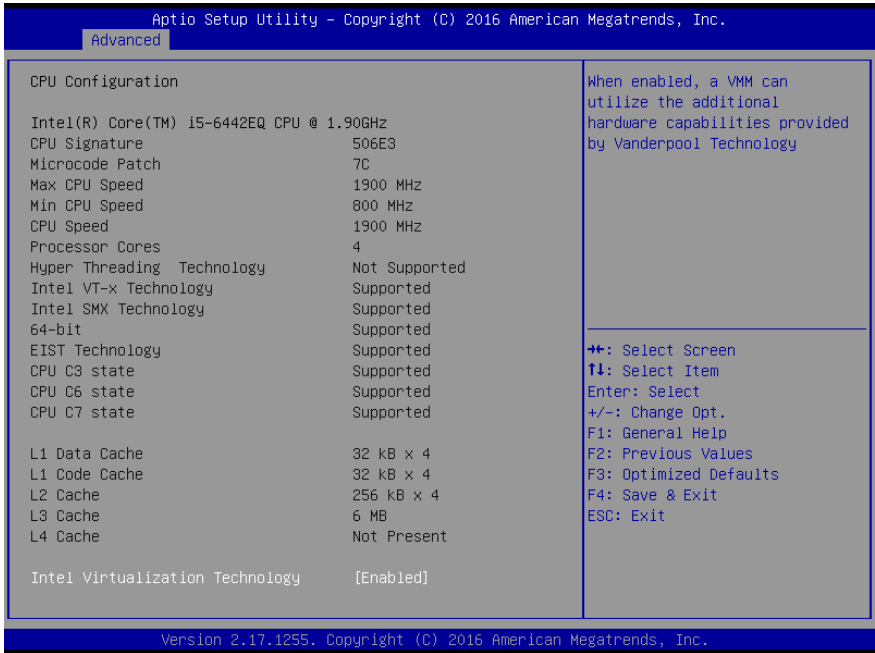

Options summary:

Intel Virtualization	Disabled	Optimal Default, Failsafe Default
Technology	Enabled	
When enabled, a VMM can utilize the additional hardware capabilities provided by Vander pool Technology		

3.4.2 Advanced: Trusted Computing

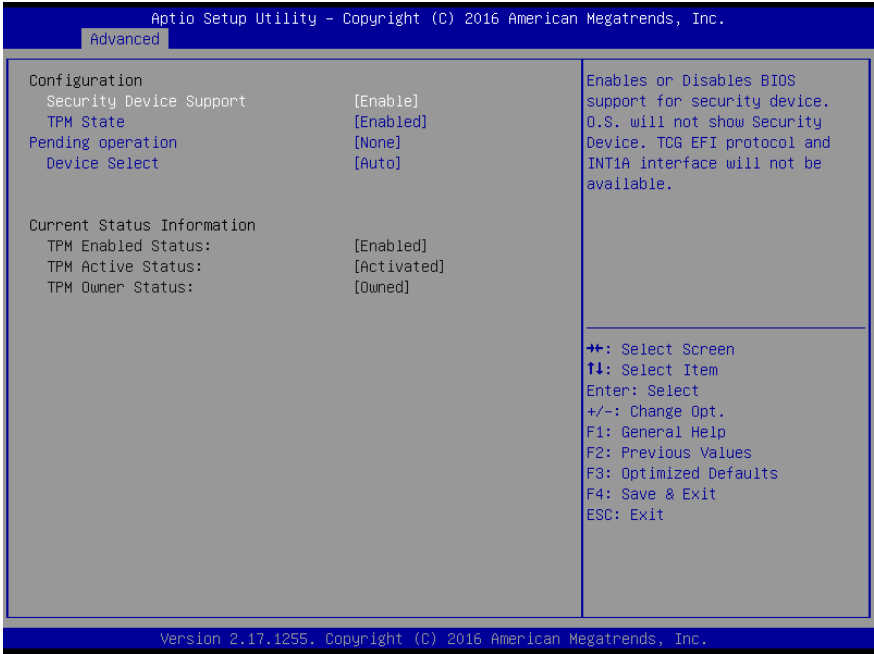

Options summary:

Security Device Support	Disabled	
	Enable	Optimal Default, Failsafe Default
En/Disable BIOS support for security device.		
TPM State	Disabled	
	Enable	Optimal Default, Failsafe Default
En/Disable security device.		
Pending operation	None	
	TPM Clear	
Schedule an operation for the security device.		

Device select	TPM 1.2	
	TPM 2.0	
	Auto	Optimal Default,
Device select		

3.4.3 Advanced: SIO Configuration

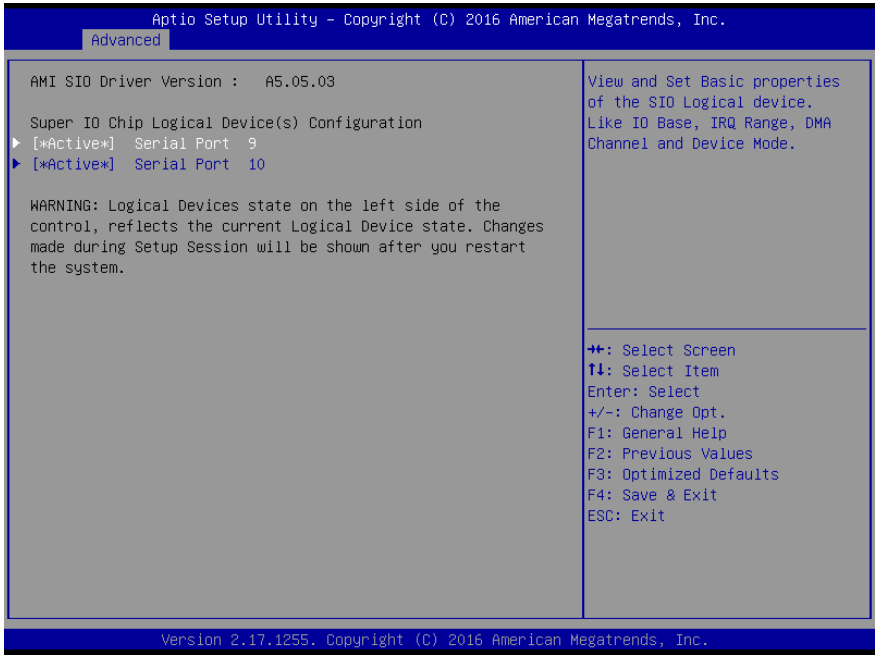

3.4.3.1 SIO Configuration: Serial Port X Configuration

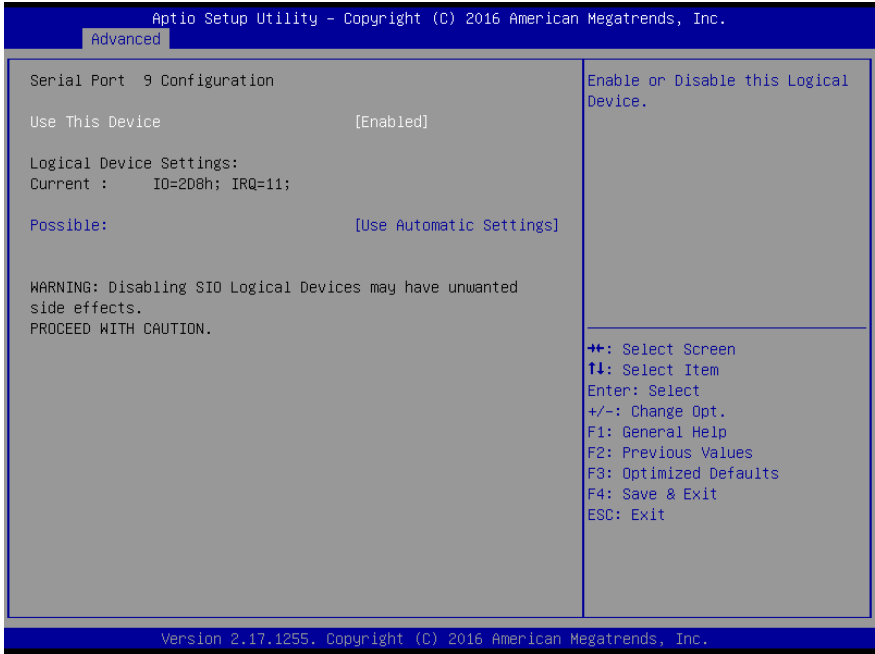

3.4.4 Advanced: On-Module H/W Monitor

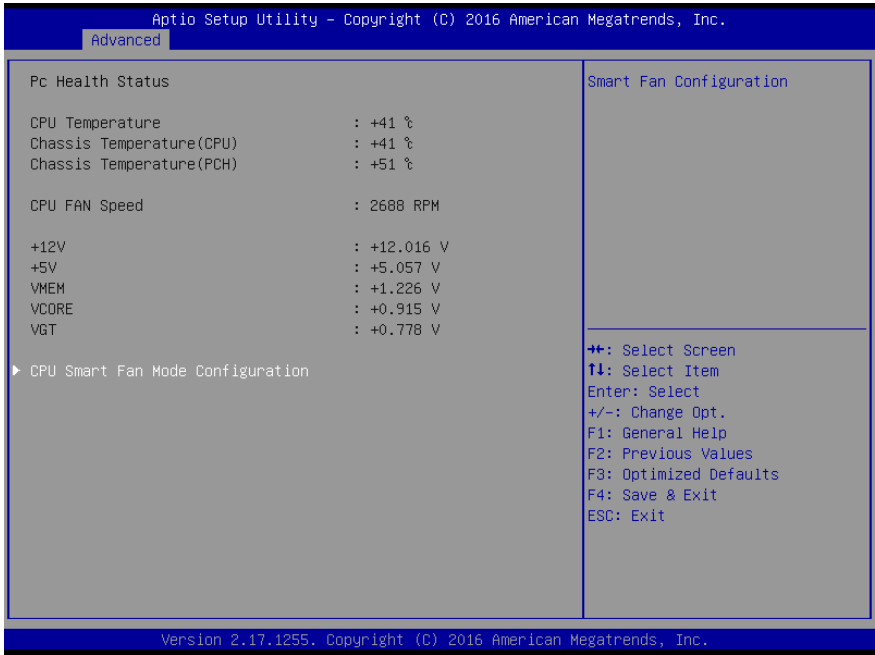

3.4.4.1 On-Module H/W Monitor: CPU Smart Fan Mode Configuration

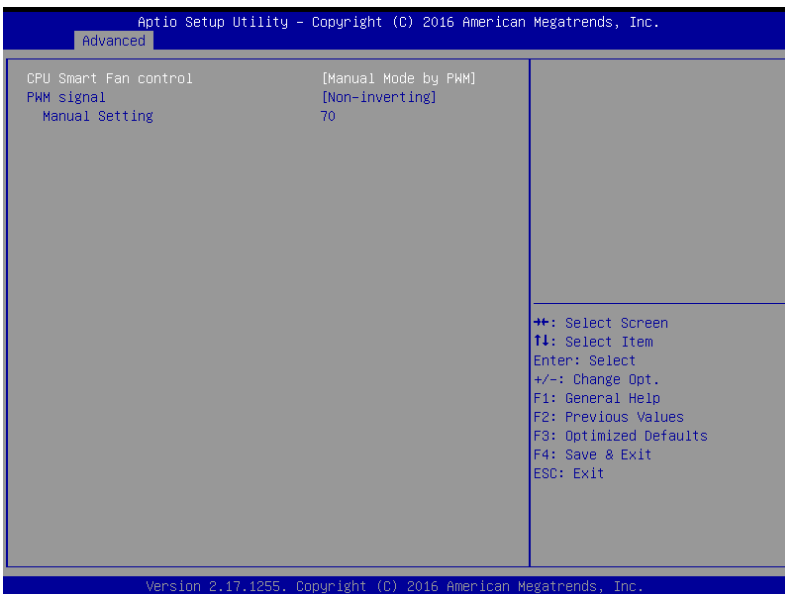
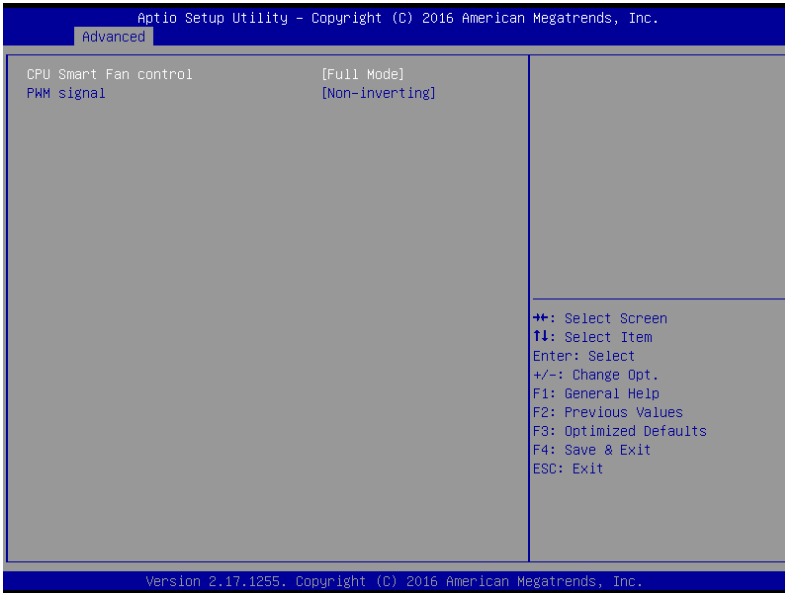

Aptio Setup Utility - Copyright (C) 2016 American Megatrends, Inc.

Advanced

CPU Smart Fan control	[Auto Mode by PWM]
PWM signal	[Non-inverting]
Temperature Of Start	30
Temperature of Off	20
Start PWM	40
Slope (PWM)	[1 (PWM)]

→+: Select Screen
↑↓: Select Item
Enter: Select
+/-: Change Opt.
F1: General Help
F2: Previous Values
F3: Optimized Defaults
F4: Save & Exit
ESC: Exit

Version 2.17.1255. Copyright (C) 2016 American Megatrends, Inc.

3.4.5 Advanced: USB Configuration

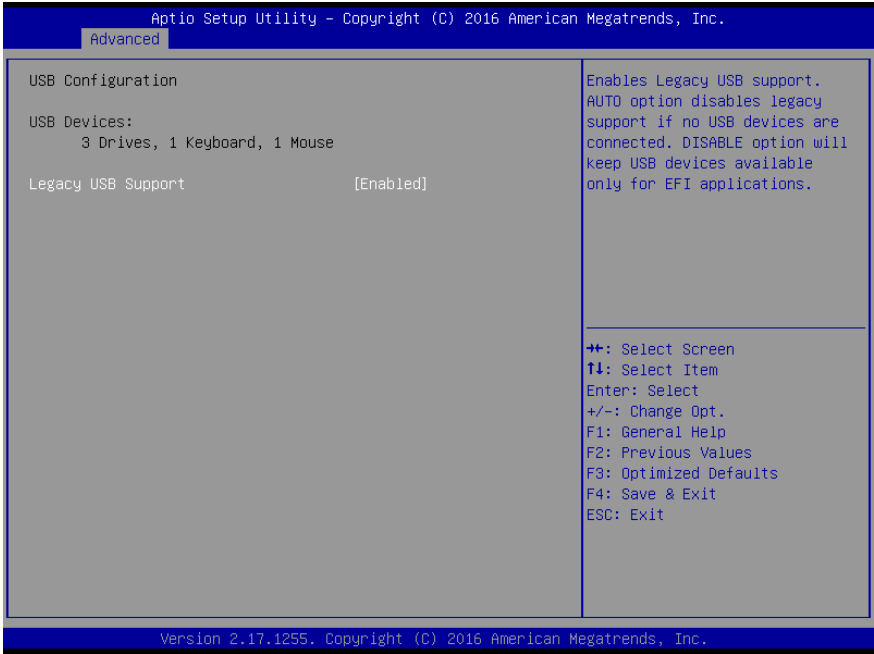

Options summary:

Legacy USB Support	Enabled	Optimal Default, Failsafe Default
	Disabled	
	Auto	
Enables BIOS Support for Legacy USB Support. When enabled, USB can be functional in legacy environment like DOS.		
AUTO option disables legacy support if no USB devices are connected		
Device Name (Emulation Type)	Auto	Optimal Default, Failsafe Default
	Floppy	
	Forced FDD	
	Hard Disk	

	CDROM
If Auto. USB devices less than 530MB will be emulated as Floppy and remaining as Floppy and remaining as hard drive. Forced FDD option can be used to force a HDD formatted drive to boot as FDD(Ex. ZIP drive)	

3.4.6 Advanced: Digital IO Port Configuration

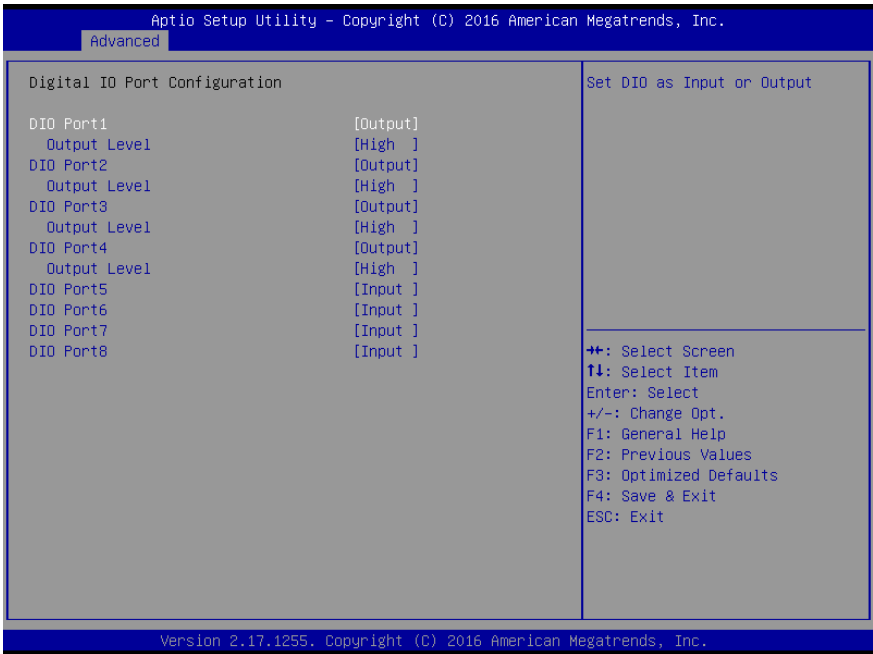

Options summary:

DIO PORT x	Input	
	Output	
Set DIO as In/Out		
Output Level	Low	
	High	

Set Output level

3.4.7 Advanced: Power Management

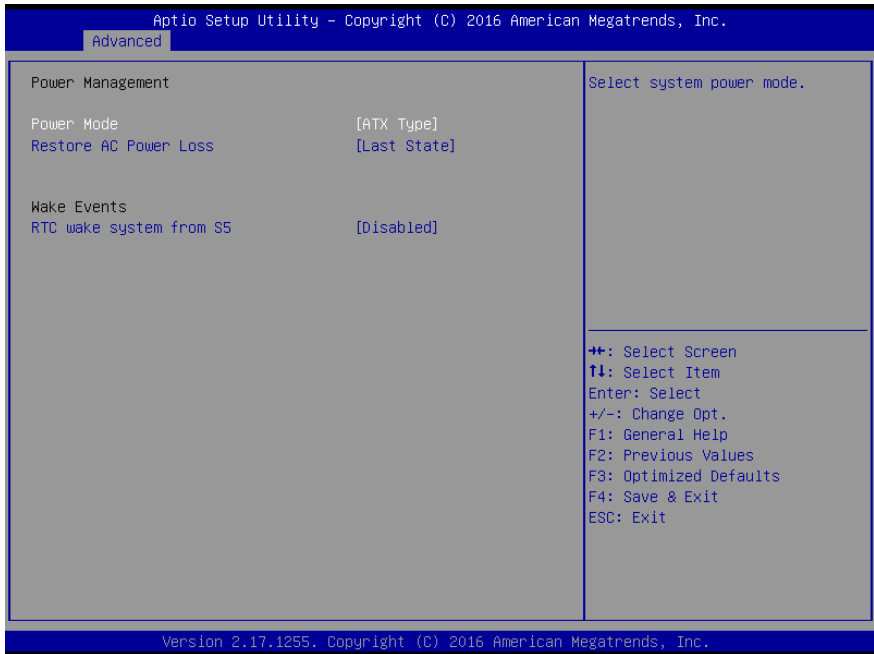

Options summary:

Power Mode	ATX Type	Optimal Default, Failsafe Default
	AT Type	
Select power supply mode		
Restore AC Power Loss	Last State	Optimal Default, Failsafe Default
	Always On	
	Always Off	
Set Power Loss state		

RTC wake system with Fixed Time		
Set System wake on alarm event. Wake up time is setting by following settings.		
Wake up day	0-31	
Select 0 for daily system wake up		
Wake up hour	0-23	
Wake up minute	0-59	
Wake up second	0-59	
RTC Wake system with Dynamic Time		
Enable or disable System wake on alarm event. Wake up time is current time + Increase minutes.		
Wake up minute increase	1-5	

3.5 Setup submenu: Chipset

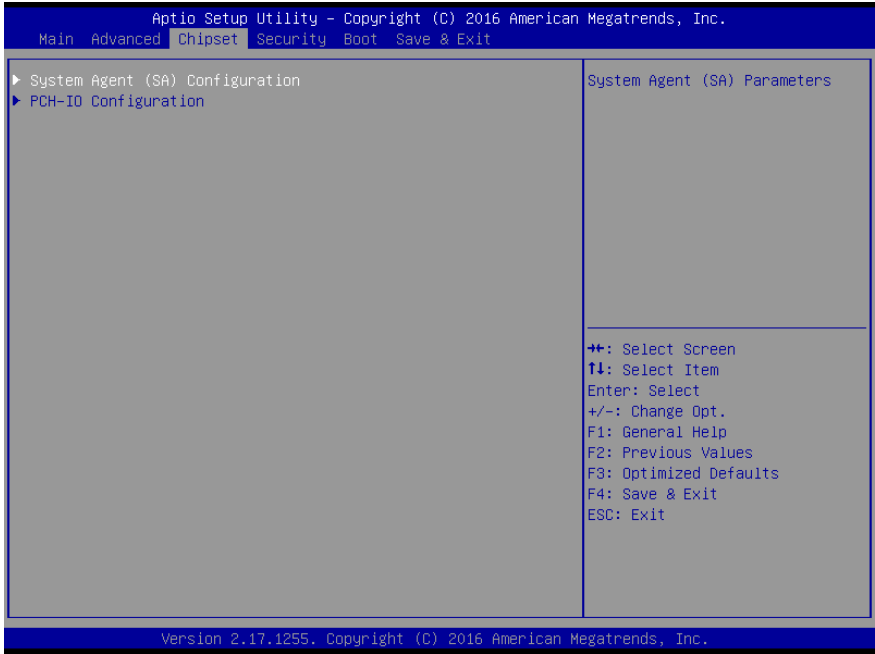

3.5.1 Chipset: System Agent (SA) Configuration

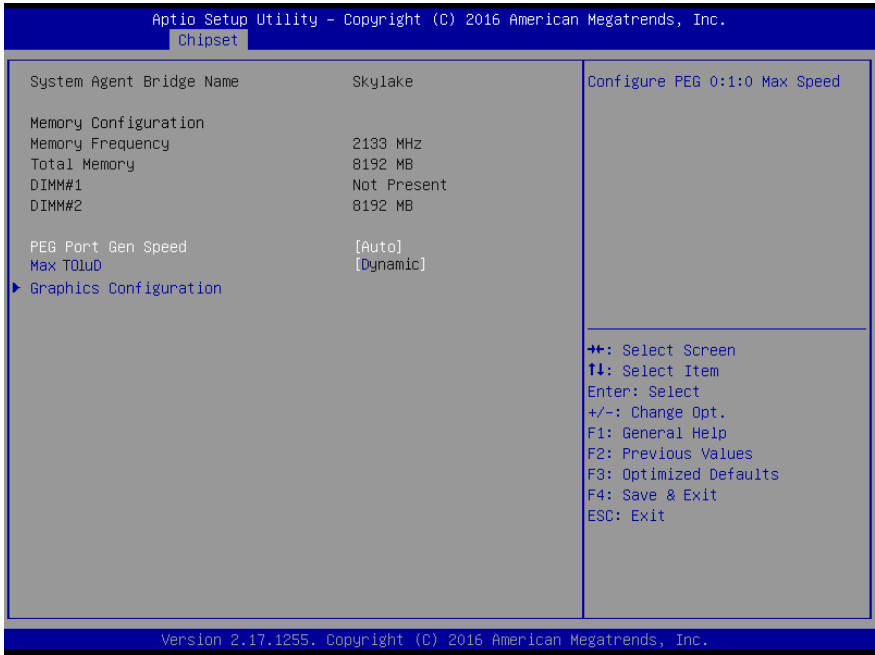

Options summary:

PEG Port Gen Speed	Auto	Optimal Default, Failsafe Default
	GEN1	
	GEN2	
	GEN3	
Configure PEG 0:1:0 Max Speed		
Max TOLUD	Dynamic	Optimal Default, Failsafe Default
	1 GB	
	1.25 GB	
	1.5 GB	
	1.75 GB	

	2 GB	
	2.25 GB	
	2.5 GB	
	2.75 GB	
	3 GB	
Maximum value of TOLUD. Dynamic assignment would adjust TOLUD automatically based on largest MMIO length of installed graphic controller		

3.5.1.1 System Agent (SA) Configuration: Graphics Configuration

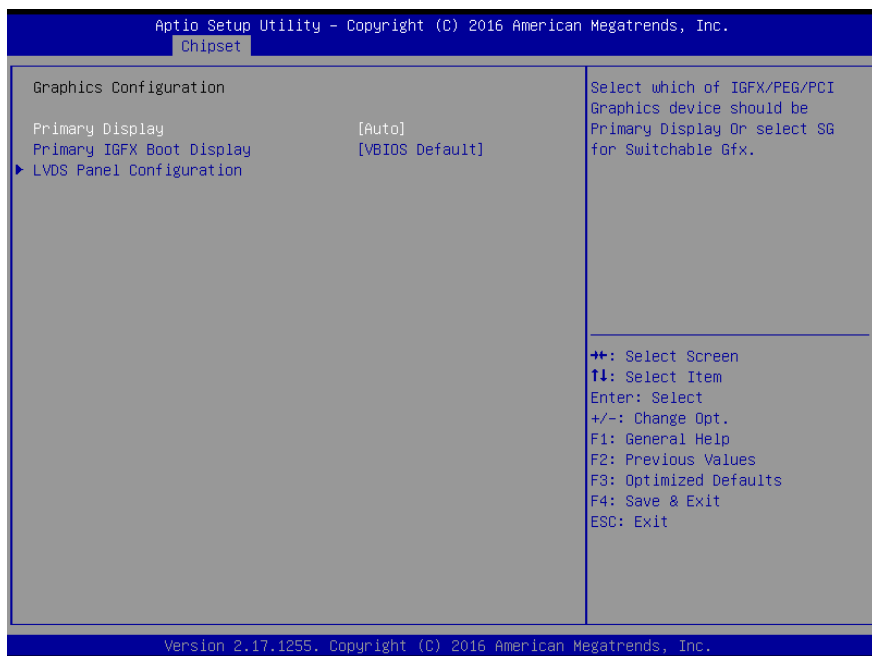

Options summary:

Primary Display	Auto	Optimal Default, Failsafe Default
	IGFX	

	PEG	
	PCIE	
Select which of IGFX/PEG/PCI Graphics device should be primary display		
Primary IGFX Boot Display	VBIOS Default	Optimal Default, Failsafe Default
	DDI1/DP	
	DDI2/DP	
	DDI3/VGA	
	LVDS/eDP	
Select the Video device which will be activated during POST.		

3.5.1.2 Graphics Configuration: LVDS Panel Configuration

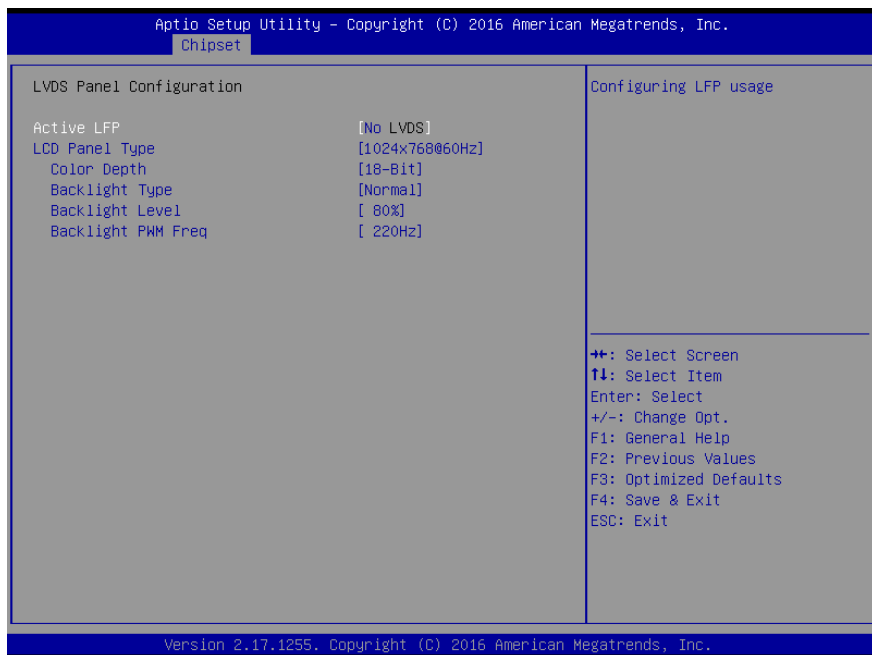

Options summary:

Active LFP	No LVDS	Default
	Enabled	
En/Disable LVDS.		
LCD Panel Type	640x480@60Hz	Default
	800x480@60Hz	
	800x600@60Hz	
	1024x600@60Hz	
	1024x768@60Hz	
	1280x768@60Hz	
	1280x800@60Hz	
	1280x1024@60Hz	
	1366x768@60Hz	
	1440x900@60Hz	
	1600x1200@60Hz	
	1920x1080@60Hz	
	1920x1200@60Hz	
Select LCD panel used by internal graphics device by selecting the appropriate setup item.		
Color Depth	18-Bit	Default
	24-Bit	
	36-Bit	
	48-Bit	
Select panel type		
Backlight Type	Normal	Default
	Inverted	
Select backlight control signal type		
Backlight Level	0-100%	Default 80

Select backlight control level		
Backlight PWM Freq	100Hz-6.5KHz	Default 220Hz
Select PWM frequency of backlight control signal		

3.5.2 Chipset: PCH-IO Configuration

Aptio Setup Utility - Copyright (C) 2016 American Megatrends, Inc.

Chipset

PCH-IO Configuration		Control Detection of the HD-Audio device. Disabled = HDA will be unconditionally disabled Enabled = HDA will be unconditionally enabled Auto = HDA will be enabled if present, disabled otherwise.
HD Audio	[Enabled]	
PCH LAN Controller	[Enabled]	++: Select Screen ↑↓: Select Item Enter: Select +/-: Change Opt. F1: General Help F2: Previous Values F3: Optimized Defaults F4: Save & Exit ESC: Exit
PCIe Lane0 Gen Speed	[Auto]	
PCIe Lane1 Gen Speed	[Auto]	
PCIe Lane2 Gen Speed	[Auto]	
PCIe Lane3 Gen Speed	[Auto]	
PCIe Lane4 Gen Speed	[Auto]	
PCIe Lane5 Gen Speed	[Auto]	
PCIe Lane6 Gen Speed	[Auto]	
PCIe Lane7 Gen Speed	[Auto]	

Version 2.17.1255. Copyright (C) 2016 American Megatrends, Inc.

Options summary:

HD Audio	Disabled	Default
	Enabled	
En/Disable HDA.		
PCH LAN Controller	Enabled	Default
	Disabled	
En/Disable onboard NIC		

PCIe Lane x Gen Speed	Auto	Default
	GEN1	
	GEN2	
	GEN3	
Select PCIe port speed		

3.6 Setup submenu: Security

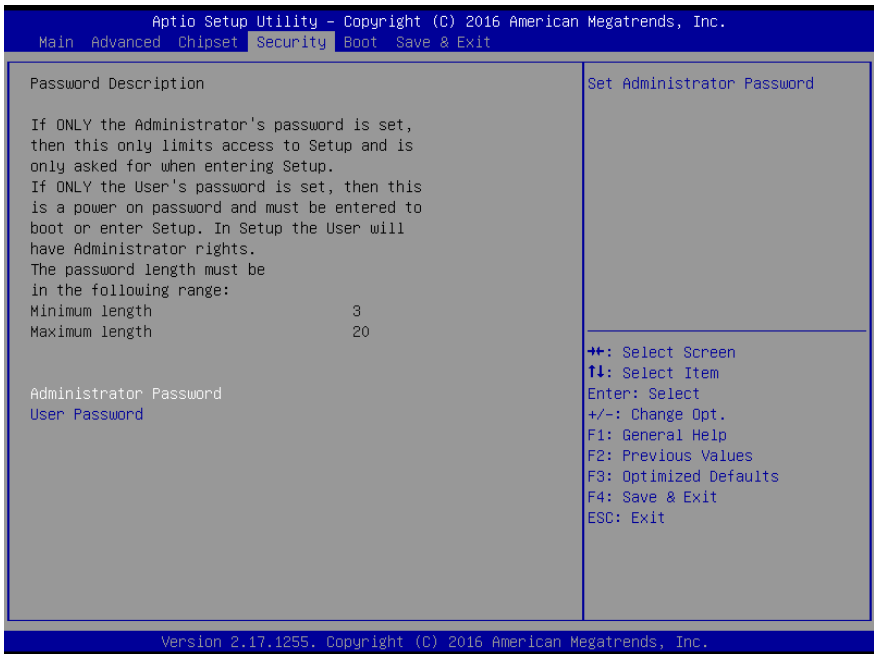

Change User/Administrator Password

You can set a User Password once an Administrator Password is set. The password will be required during boot up, or when the user enters the Setup utility. Please Note that a User Password does not provide access to many of the features in the Setup utility.

Select the password you wish to set, press Enter to open a dialog box to enter your

password (you can enter no more than six letters or numbers). Press Enter to confirm your entry, after which you will be prompted to retype your password for a final confirmation. Press Enter again after you have retyped it correctly.

Removing the Password

Highlight this item and type in the current password. At the next dialog box press Enter to disable password protection.

3.7 Setup submenu: Boot

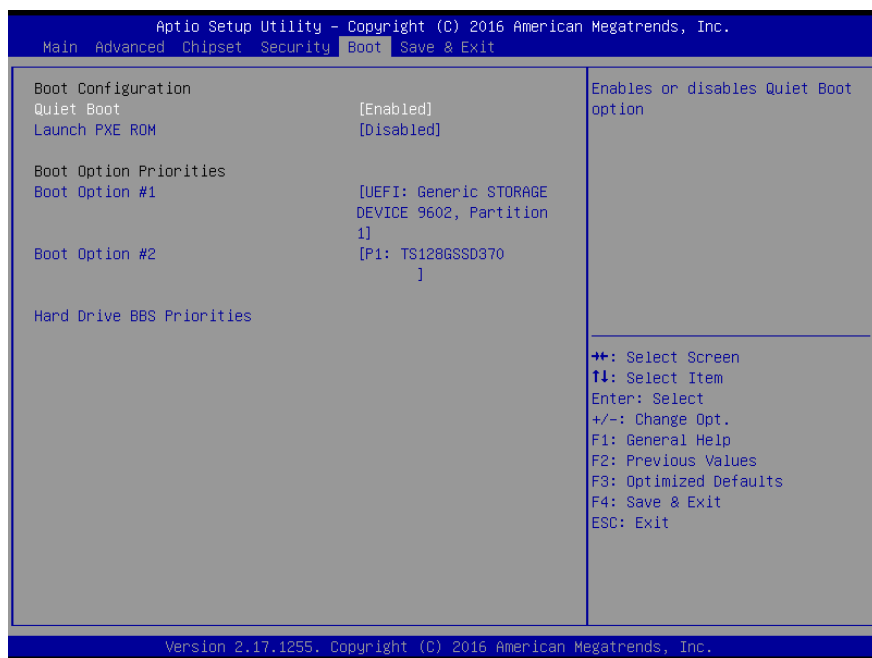

Options summary:

Quiet Boot	Disabled	Default
	Enabled	
En/Disable showing boot logo.		

Launch PXE ROM	Disabled	Default
	Enabled	
En/Disable PXE boot		

3.8 Setup submenu: Save & Exit

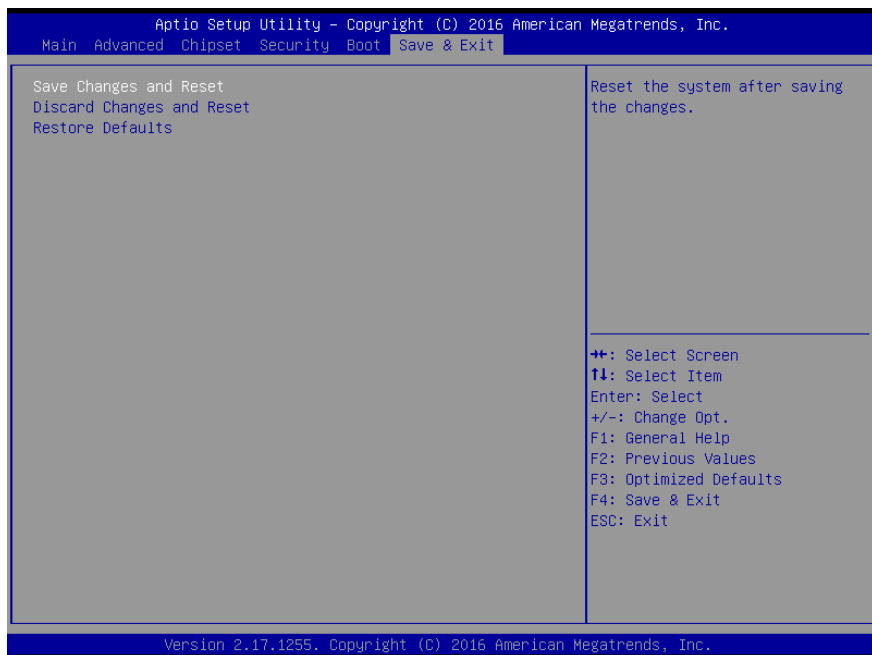

Chapter 4

Drivers Installation

4.1 Driver Download/Installation

Drivers for the COM-SKHB6 can be downloaded from the product page on the AAEON website by following this link:

<https://www.aaeon.com/en/p/com-express-modules-com-skhb6>

Download the driver(s) you need and follow the steps below to install them.

Step 1 – Install Chipset Driver

1. Open the **Step1 - Chipset** folder followed by **SetupChipset.exe**
2. Follow the instructions
3. Drivers will be installed automatically

Step 2 – Install Graphics Driver

1. Open the **Step2 - Graphics** folder and select your OS
2. Open the **Setup.exe** file in the folder
3. Follow the instructions
4. Drivers will be installed automatically

Step 3 – Install LAN Driver

1. Open the **Step3 - LAN** folder and select your OS
2. Open the **Setup.exe** file in the folder
3. Follow the instructions
4. Drivers will be installed automatically

Step 4 – Install Audio Driver

1. Open the **STEP4 - Audio** folder followed by **0002-Win7_Win8_Win81_R276.exe**
2. Follow the instructions
3. Drivers will be installed automatically

Step 5 – Install USB 3.0 Driver

1. Open the **STEP5 – USB3.0** folder and select your OS
2. Open the **.exe** file in the folder
3. Follow the instructions
4. Drivers will be installed automatically

Step 6 – Install ME Driver

1. Open the **STEP6 - TXE** folder followed by **SetupME.exe**
2. Follow the instructions
3. Drivers will be installed automatically

Appendix A

Watchdog Timer Programming

A.1 Watchdog Timer Initial Program

Table 1 : Embedded BRAM relative register table

	Default Value	Note
Index	0x284(Note1)	BRAM Index Register
Data	0x285(Note2)	BRAM Data Register
Logical Device Number	0xA8(Note3)	Watch dog Logical Device Number
Function and Device Number	0x00(Note4)	Watch dog Function/Device Number

Table 2 : Watchdog relative register table

	Option Register	BitNum	Value	Note
Timer Counter	0x00(Note5)		(Note10)	Time of watchdog timer (0~255)
Counting Unit	0x01(Note6)	0(Note7)	0(Note11)	Select time unit. 0: second 1: minute
Watchdog RST pulse width	0x01(Note8)	[3:2](Note9)	0(Note12)	0: 20ms 1: 60ms 2: 100ms 3: 250ms

```
*****
// Embedded BRAM relative definition (Please reference to Table 1)
#define byte EcBRAMIndex //This parameter is represented from Note1
#define byte EcBRAMData //This parameter is represented from Note2
#define byte BRAMLDRReg //This parameter is represented from Note3
#define byte BRAMFnDataReg //This parameter is represented from Note4
#define void EcBRAMWriteByte(byte Offset, byte Value);
#define byte EcBRAMReadByte(byte Offset);
#define void IOWriteByte(byte Offset, byte Value);
#define byte IOReadByte(byte Offset);
// Watch Dog relative definition (Please reference to Table 2)
#define byte TimerReg //This parameter is represented from Note5
#define byte TimerVal // This parameter is represented from Note10
#define byte UnitReg //This parameter is represented from Note6
#define byte UnitBit //This parameter is represented from Note7
#define byte UnitVal //This parameter is represented from Note11
#define byte RSTReg //This parameter is represented from Note8
#define byte RSTBit //This parameter is represented from Note9
#define byte RSTVal //This parameter is represented from Note12
*****
```

```
*****  
VOID Main()  
    // Procedure : AaeonWDTConfig  
    // (byte)Timer : Time of WDT timer.(0x00~0xFF)  
    // (boolean)Unit : Select time unit(0: second, 1: minute).  
    AaeonWDTConfig();  
  
    // Procedure : AaeonWDTEnable  
    // This procedure will enable the WDT counting.  
    AaeonWDTEnable();  
}  
*****
```

```
*****
// Procedure : AaeonWDTEnable
VOID AaeonWDTEnable (){
    WDTEnableDisable(1);
}

// Procedure : AaeonWDTConfig
VOID AaeonWDTConfig (){
    // Disable WDT counting
    WDTEnableDisable(0);
    // WDT relative parameter setting
    WDTParameterSetting();
}

VOID WDTEnableDisable(byte Value){
    ECBRAMWriteByte(TimerReg , Value);
}

VOID WDTParameterSetting(){
    Byte TempByte;

    // Watchdog Timer counter setting
    ECBRAMWriteByte(TimerReg , TimerVal);
    // WDT counting unit setting
    TempByte = ECBRAMReadByte(UnitReg);
    TempByte |= (UnitVal << UnitBit);
    ECBRAMWriteByte(UnitReg , TempByte);
    // WDT RST pulse width setting
    TempByte = ECBRAMReadByte(RSTReg);
    TempByte |= (RSTVal << RSTBit);
    ECBRAMWriteByte(RSTReg , TempByte);
}
*****
```

```

*****
VOID  ECBRAMWriteByte(byte OPReg, byte OPBit, byte Value){
    IOWriteByte(EcBRAMIndex, 0x10);
    IOWriteByte(EcBRAMData, BRAMLDNReg);
    IOWriteByte(EcBRAMIndex, 0x11);
    IOWriteByte(EcBRAMData, BRAMFnDataReg);

    IOWriteByte(EcBRAMIndex, 0x13 + OPReg);
    IOWriteByte(EcBRAMData, Value);

    IOWriteByte(EcBRAMIndex, 0x12);
    IOWriteByte(EcBRAMData, 0x30);           //Write start
}

Byte  ECBRAMReadByte(byte OPReg){
    IOWriteByte(EcBRAMIndex, 0x10);
    IOWriteByte(EcBRAMData, BRAMLDNReg);
    IOWriteByte(EcBRAMIndex, 0x11);
    IOWriteByte(EcBRAMData, BRAMFnDataReg);

    IOWriteByte(EcBRAMIndex, 0x12);
    IOWriteByte(EcBRAMData, 0x10);         //Read start

    IOWriteByte(EcBRAMIndex, 0x13 + OPReg);
    Return    IOReadByte(EcBRAMData, Value);
}
*****









































```











































Appendix B

I/O Information

B.1 I/O Address Map





























Input/output (IO)	
[0000000000000000 - 000000000000CF7]	PCI Express Root Complex
[0000000000000020 - 0000000000000021]	Programmable interrupt controller
[0000000000000020 - 0000000000000021]	Programmable interrupt controller
[0000000000000020 - 0000000000000021]	Programmable interrupt controller
[0000000000000024 - 0000000000000025]	Programmable interrupt controller
[0000000000000024 - 0000000000000025]	Programmable interrupt controller
[0000000000000024 - 0000000000000025]	Programmable interrupt controller
[0000000000000028 - 0000000000000029]	Programmable interrupt controller
[0000000000000028 - 0000000000000029]	Programmable interrupt controller
[0000000000000028 - 0000000000000029]	Programmable interrupt controller
[000000000000002C - 000000000000002D]	Programmable interrupt controller
[000000000000002C - 000000000000002D]	Programmable interrupt controller
[000000000000002C - 000000000000002D]	Programmable interrupt controller
[000000000000002E - 000000000000002F]	Motherboard resources
[0000000000000030 - 0000000000000031]	Programmable interrupt controller
[0000000000000030 - 0000000000000031]	Programmable interrupt controller
[0000000000000030 - 0000000000000031]	Programmable interrupt controller
[0000000000000034 - 0000000000000035]	Programmable interrupt controller
[0000000000000034 - 0000000000000035]	Programmable interrupt controller
[0000000000000034 - 0000000000000035]	Programmable interrupt controller
[0000000000000038 - 0000000000000039]	Programmable interrupt controller
[0000000000000038 - 0000000000000039]	Programmable interrupt controller
[0000000000000038 - 0000000000000039]	Programmable interrupt controller
[000000000000003C - 000000000000003D]	Programmable interrupt controller
[000000000000003C - 000000000000003D]	Programmable interrupt controller
[000000000000003C - 000000000000003D]	Programmable interrupt controller
[0000000000000040 - 0000000000000043]	System timer
[0000000000000040 - 0000000000000043]	System timer
[0000000000000040 - 0000000000000043]	System timer
[000000000000004E - 000000000000004F]	Motherboard resources
[0000000000000050 - 0000000000000053]	System timer
[0000000000000050 - 0000000000000053]	System timer
[0000000000000050 - 0000000000000053]	System timer
[0000000000000060 - 0000000000000060]	Standard PS/2 Keyboard
[0000000000000060 - 0000000000000060]	Standard PS/2 Keyboard
[0000000000000061 - 0000000000000061]	Motherboard resources
[0000000000000063 - 0000000000000063]	Motherboard resources
[0000000000000064 - 0000000000000064]	Standard PS/2 Keyboard
[0000000000000064 - 0000000000000064]	Standard PS/2 Keyboard

	[000000000000065 - 000000000000065]	Motherboard resources
	[000000000000067 - 000000000000067]	Motherboard resources
	[000000000000070 - 000000000000070]	Motherboard resources
	[000000000000070 - 000000000000077]	System CMOS/real time clock
	[000000000000070 - 000000000000077]	System CMOS/real time clock
	[000000000000070 - 000000000000077]	System CMOS/real time clock
	[000000000000080 - 000000000000080]	Motherboard resources
	[000000000000092 - 000000000000092]	Motherboard resources
	[0000000000000A0 - 0000000000000A1]	Programmable interrupt controller
	[0000000000000A0 - 0000000000000A1]	Programmable interrupt controller
	[0000000000000A0 - 0000000000000A1]	Programmable interrupt controller
	[0000000000000A4 - 0000000000000A5]	Programmable interrupt controller
	[0000000000000A4 - 0000000000000A5]	Programmable interrupt controller
	[0000000000000A4 - 0000000000000A5]	Programmable interrupt controller
	[0000000000000A8 - 0000000000000A9]	Programmable interrupt controller
	[0000000000000A8 - 0000000000000A9]	Programmable interrupt controller
	[0000000000000A8 - 0000000000000A9]	Programmable interrupt controller
	[0000000000000AC - 0000000000000AD]	Programmable interrupt controller
	[0000000000000AC - 0000000000000AD]	Programmable interrupt controller
	[0000000000000AC - 0000000000000AD]	Programmable interrupt controller
	[0000000000000B0 - 0000000000000B1]	Programmable interrupt controller
	[0000000000000B0 - 0000000000000B1]	Programmable interrupt controller
	[0000000000000B0 - 0000000000000B1]	Programmable interrupt controller
	[0000000000000B2 - 0000000000000B3]	Motherboard resources
	[0000000000000B4 - 0000000000000B5]	Programmable interrupt controller
	[0000000000000B4 - 0000000000000B5]	Programmable interrupt controller
	[0000000000000B4 - 0000000000000B5]	Programmable interrupt controller
	[0000000000000B8 - 0000000000000B9]	Programmable interrupt controller
	[0000000000000B8 - 0000000000000B9]	Programmable interrupt controller
	[0000000000000B8 - 0000000000000B9]	Programmable interrupt controller
	[0000000000000B8 - 0000000000000B9]	Programmable interrupt controller
	[0000000000000BC - 0000000000000BD]	Programmable interrupt controller
	[0000000000000BC - 0000000000000BD]	Programmable interrupt controller
	[0000000000000BC - 0000000000000BD]	Programmable interrupt controller
	[0000000000000F0 - 0000000000000F0]	Numeric data processor
	[0000000000000F0 - 0000000000000F0]	Numeric data processor
	[0000000000002C8 - 0000000000002CF]	Communications Port (COM10)
	[0000000000002D8 - 0000000000002DF]	Communications Port (COM9)
	[0000000000002E8 - 0000000000002EF]	Communications Port (COM4)
	[0000000000002F8 - 0000000000002FF]	Communications Port (COM1)











































	[0000000000003B0 - 0000000000003BB]	Intel(R) HD Graphics 530
	[0000000000003C0 - 0000000000003DF]	Intel(R) HD Graphics 530
	[0000000000003E8 - 0000000000003EF]	Communications Port (COM2)
	[0000000000003F8 - 0000000000003FF]	Communications Port (COM1)
	[0000000000004D0 - 0000000000004D1]	Programmable interrupt controller
	[0000000000004D0 - 0000000000004D1]	Programmable interrupt controller
	[0000000000004D0 - 0000000000004D1]	Programmable interrupt controller
	[000000000000680 - 00000000000069F]	Motherboard resources
	[000000000000800 - 00000000000087F]	Motherboard resources
	[000000000000D00 - 000000000000FFF]	PCI Express Root Complex
	[000000000000164E - 000000000000164F]	Motherboard resources
	[0000000000001800 - 00000000000018FE]	Motherboard resources
	[0000000000001854 - 0000000000001857]	Motherboard resources
	[0000000000001854 - 0000000000001857]	Motherboard resources
	[0000000000001854 - 0000000000001857]	Motherboard resources
	[000000000000D000 - 000000000000D01F]	Intel(R) I210 Gigabit Network Connection #2
	[000000000000D000 - 000000000000DFFF]	PCI Express standard Root Port
	[000000000000E000 - 000000000000E01F]	Intel(R) I210 Gigabit Network Connection
	[000000000000E000 - 000000000000E01F]	Intel(R) I211 Gigabit Network Connection
	[000000000000E000 - 000000000000EFFF]	Intel(R) 100 Series/C230 Series Chipset Family PCI Express Root Port #6 - A115
	[000000000000E000 - 000000000000EFFF]	PCI Express standard Root Port
	[000000000000F000 - 000000000000F03F]	Intel(R) HD Graphics 510
	[000000000000F000 - 000000000000F03F]	Intel(R) HD Graphics 530
	[000000000000F000 - 000000000000F03F]	Intel(R) HD Graphics 530
	[000000000000F040 - 000000000000F05F]	Intel(R) 100 Series/C230 Series Chipset Family SMBus - A123
	[000000000000F040 - 000000000000F05F]	SM Bus Controller
	[000000000000F060 - 000000000000F07F]	Standard SATA AHCI Controller
	[000000000000F060 - 000000000000F07F]	Standard SATA AHCI Controller
	[000000000000F060 - 000000000000F07F]	Standard SATA AHCI Controller
	[000000000000F080 - 000000000000F083]	Standard SATA AHCI Controller
	[000000000000F080 - 000000000000F083]	Standard SATA AHCI Controller
	[000000000000F080 - 000000000000F083]	Standard SATA AHCI Controller
	[000000000000F090 - 000000000000F097]	Standard SATA AHCI Controller
	[000000000000F090 - 000000000000F097]	Standard SATA AHCI Controller
	[000000000000F090 - 000000000000F097]	Standard SATA AHCI Controller
	[000000000000F0A0 - 000000000000F0A7]	Intel(R) Active Management Technology - SOL (COM3)
	[000000000000FF00 - 000000000000FFFE]	Motherboard resources
	[000000000000FFFF - 000000000000FFFF]	Motherboard resources
	[000000000000FFFF - 000000000000FFFF]	Motherboard resources
	[000000000000FFFF - 000000000000FFFF]	Motherboard resources
		Interrupt request (IRQ)
		Memory









































B.2 Memory Address Map

Address Range	Device Name
[0000000000A0000 - 0000000000BFFFF]	Intel(R) HD Graphics 530
[0000000000A0000 - 0000000000BFFFF]	PCI Express Root Complex
[0000000090000000 - 00000000DFFFFFFF]	PCI Express Root Complex
[00000000C0000000 - 00000000CFFFFFFF]	Intel(R) HD Graphics 510
[00000000C0000000 - 00000000CFFFFFFF]	Intel(R) HD Graphics 530
[00000000C0000000 - 00000000CFFFFFFF]	Intel(R) HD Graphics 530
[00000000DE000000 - 00000000DEFFFFFF]	Intel(R) HD Graphics 510
[00000000DE000000 - 00000000DEFFFFFF]	Intel(R) HD Graphics 530
[00000000DE000000 - 00000000DEFFFFFF]	Intel(R) HD Graphics 530
[00000000DF000000 - 00000000DF01FFFF]	Intel(R) Ethernet Connection (2) I219-LM
[00000000DF000000 - 00000000DF01FFFF]	Intel(R) Ethernet Connection (2) I219-V
[00000000DF000000 - 00000000DF01FFFF]	Intel(R) I210 Gigabit Network Connection #2
[00000000DF000000 - 00000000DF01FFFF]	Intel(R) I211 Gigabit Network Connection
[00000000DF000000 - 00000000DF0FFFFF]	Intel(R) 100 Series/C230 Series Chipset Family PCI Express Root Port #6 - A115
[00000000DF000000 - 00000000DF0FFFFF]	PCI Express standard Root Port
[00000000DF020000 - 00000000DF023FFF]	Intel(R) I210 Gigabit Network Connection #2
[00000000DF020000 - 00000000DF023FFF]	Intel(R) I211 Gigabit Network Connection
[00000000DF020000 - 00000000DF02FFFF]	High Definition Audio Controller
[00000000DF030000 - 00000000DF03FFFF]	Intel(R) USB 3.0 eXtensible Host Controller - 0100 (Microsoft)
[00000000DF040000 - 00000000DF043FFF]	High Definition Audio Controller
[00000000DF044000 - 00000000DF047FFF]	Intel(R) 100 Series/C230 Series Chipset Family PMC - A121
[00000000DF048000 - 00000000DF049FFF]	Standard SATA AHCI Controller
[00000000DF04A000 - 00000000DF04A0FF]	Intel(R) 100 Series/C230 Series Chipset Family SMBus - A123
[00000000DF04B000 - 00000000DF04B7FF]	Standard SATA AHCI Controller
[00000000DF04C000 - 00000000DF04C0FF]	Standard SATA AHCI Controller
[00000000DF04D000 - 00000000DF04DFFF]	Intel(R) Active Management Technology - SOL (COM3)
[00000000DF04E000 - 00000000DF04EFFF]	Intel(R) 100 Series/C230 Series Chipset Family Thermal subsystem - A131
[00000000DF100000 - 00000000DF11FFFF]	Intel(R) I210 Gigabit Network Connection
[00000000DF100000 - 00000000DF11FFFF]	PCI Express standard Root Port
[00000000DF120000 - 00000000DF123FFF]	Intel(R) I210 Gigabit Network Connection
[00000000DF148000 - 00000000DF149FFF]	Standard SATA AHCI Controller
[00000000DF14B000 - 00000000DF14B7FF]	Standard SATA AHCI Controller
[00000000DF14C000 - 00000000DF14C0FF]	Standard SATA AHCI Controller
[00000000DF200000 - 00000000DF20FFFF]	High Definition Audio Controller
[00000000DF210000 - 00000000DF21FFFF]	Intel(R) USB 3.0 eXtensible Host Controller - 0100 (Microsoft)
[00000000DF220000 - 00000000DF223FFF]	High Definition Audio Controller
[00000000DF224000 - 00000000DF227FFF]	PCI Memory Controller
[00000000DF228000 - 00000000DF229FFF]	Standard SATA AHCI Controller
[00000000DF22A000 - 00000000DF22A0FF]	SM Bus Controller
[00000000DF22B000 - 00000000DF22B7FF]	Standard SATA AHCI Controller

	[00000000DF22C000 - 00000000DF22C0FF]	Standard SATA AHCI Controller
	[00000000DF22E000 - 00000000DF22EFFF]	PCI Data Acquisition and Signal Processing Controller
	[00000000DFFE0000 - 00000000DFFFFFFF]	Motherboard resources
	[00000000E0000000 - 00000000EFFFFFFF]	Motherboard resources
	[00000000FD000000 - 00000000FDABFFFF]	Motherboard resources
	[00000000FD000000 - 00000000FE7FFFFF]	PCI Express Root Complex
	[00000000FDAC0000 - 00000000FDACFFFF]	Motherboard resources
	[00000000FDAD0000 - 00000000FDADFFFF]	Motherboard resources
	[00000000FDAE0000 - 00000000FDAEFFFF]	Motherboard resources
	[00000000FDAF0000 - 00000000FDAFFFFFFF]	Motherboard resources
	[00000000FDB00000 - 00000000FDBFFFFFFF]	Motherboard resources
	[00000000FE000000 - 00000000FE01FFFF]	Motherboard resources
	[00000000FE036000 - 00000000FE03BFFF]	Motherboard resources
	[00000000FE03D000 - 00000000FE03FFFF]	Motherboard resources
	[00000000FE40F000 - 00000000FE40FFFF]	Intel(R) Management Engine Interface
	[00000000FE410000 - 00000000FE7FFFFF]	Motherboard resources
	[00000000FED00000 - 00000000FED003FF]	High precision event timer
	[00000000FED10000 - 00000000FED17FFF]	Motherboard resources
	[00000000FED18000 - 00000000FED18FFF]	Motherboard resources
	[00000000FED19000 - 00000000FED19FFF]	Motherboard resources
	[00000000FED20000 - 00000000FED3FFFF]	Motherboard resources
	[00000000FED40000 - 00000000FED40FFF]	Trusted Platform Module 1.2
	[00000000FED45000 - 00000000FED8FFFF]	Motherboard resources
	[00000000FED90000 - 00000000FED93FFF]	Motherboard resources
	[00000000FEE00000 - 00000000FEEFFFFFFF]	Motherboard resources
	[00000000FF000000 - 00000000FFFFFFFF]	Intel(R) 82802 Firmware Hub Device
	[00000000FF000000 - 00000000FFFFFFFF]	Intel(R) 82802 Firmware Hub Device
	[00000000FF000000 - 00000000FFFFFFFF]	Intel(R) 82802 Firmware Hub Device
	[00000000FF000000 - 00000000FFFFFFFF]	Motherboard resources

B.3 IRQ Mapping Chart

4		Interrupt request (IRQ)
		(ISA) 0x00000000 (00) System timer
		(ISA) 0x00000000 (00) System timer
		(ISA) 0x00000000 (00) System timer
		(ISA) 0x00000001 (01) Standard PS/2 Keyboard
		(ISA) 0x00000001 (01) Standard PS/2 Keyboard
		(ISA) 0x00000003 (03) Communications Port (COM1)
		(ISA) 0x00000004 (04) Communications Port (COM1)
		(ISA) 0x00000008 (08) System CMOS/real time clock
		(ISA) 0x00000008 (08) System CMOS/real time clock
		(ISA) 0x00000008 (08) System CMOS/real time clock
		(ISA) 0x0000000A (10) Communications Port (COM2)
		(ISA) 0x0000000A (10) Communications Port (COM2)
		(ISA) 0x0000000A (10) Communications Port (COM4)
		(ISA) 0x0000000B (11) Communications Port (COM9)
		(ISA) 0x0000000B (11) High Definition Audio Controller
		(ISA) 0x0000000B (11) Intel(R) 100 Series/C230 Series Chipset Family PCI Express Root Port #1 - A110
		(ISA) 0x0000000B (11) Intel(R) Ethernet Connection (2) I219-V
		(ISA) 0x0000000B (11) Intel(R) HD Graphics 510
		(ISA) 0x0000000B (11) Intel(R) HD Graphics 530
		(ISA) 0x0000000B (11) Intel(R) I210 Gigabit Network Connection
		(ISA) 0x0000000B (11) Intel(R) I210 Gigabit Network Connection #2
		(ISA) 0x0000000B (11) Intel(R) I211 Gigabit Network Connection
		(ISA) 0x0000000B (11) Intel(R) USB 3.0 eXtensible Host Controller - 0100 (Microsoft)
		(ISA) 0x0000000B (11) PCI Data Acquisition and Signal Processing Controller
		(ISA) 0x0000000B (11) PCI Express standard Root Port
		(ISA) 0x0000000B (11) PCI Express standard Root Port
		(ISA) 0x0000000B (11) SM Bus Controller
		(ISA) 0x0000000B (11) Standard SATA AHCI Controller
		(ISA) 0x0000000B (11) Standard SATA AHCI Controller
		(ISA) 0x0000000C (12) Logitech PS/2 Port Mouse
		(ISA) 0x0000000C (12) PS/2 Compatible Mouse
		(ISA) 0x0000000D (13) Numeric data processor
		(ISA) 0x0000000D (13) Numeric data processor
		(ISA) 0x0000000E (14) Motherboard resources
		(ISA) 0x00000051 (81) Microsoft ACPI-Compliant System
		(ISA) 0x00000052 (82) Microsoft ACPI-Compliant System
		(ISA) 0x00000053 (83) Microsoft ACPI-Compliant System
		(ISA) 0x00000054 (84) Microsoft ACPI-Compliant System
		(ISA) 0x00000055 (85) Microsoft ACPI-Compliant System
		(ISA) 0x00000056 (86) Microsoft ACPI-Compliant System
		(ISA) 0x00000057 (87) Microsoft ACPI-Compliant System

	(ISA) 0x000001DF (479)	Microsoft ACPI-Compliant System
	(ISA) 0x000001E0 (480)	Microsoft ACPI-Compliant System
	(ISA) 0x000001E1 (481)	Microsoft ACPI-Compliant System
	(ISA) 0x000001E2 (482)	Microsoft ACPI-Compliant System
	(ISA) 0x000001E3 (483)	Microsoft ACPI-Compliant System
	(ISA) 0x000001E4 (484)	Microsoft ACPI-Compliant System
	(ISA) 0x000001E5 (485)	Microsoft ACPI-Compliant System
	(ISA) 0x000001E6 (486)	Microsoft ACPI-Compliant System
	(ISA) 0x000001E7 (487)	Microsoft ACPI-Compliant System
	(ISA) 0x000001E8 (488)	Microsoft ACPI-Compliant System
	(ISA) 0x000001E9 (489)	Microsoft ACPI-Compliant System
	(ISA) 0x000001EA (490)	Microsoft ACPI-Compliant System
	(ISA) 0x000001EB (491)	Microsoft ACPI-Compliant System
	(ISA) 0x000001EC (492)	Microsoft ACPI-Compliant System
	(ISA) 0x000001ED (493)	Microsoft ACPI-Compliant System
	(ISA) 0x000001EE (494)	Microsoft ACPI-Compliant System
	(ISA) 0x000001EF (495)	Microsoft ACPI-Compliant System
	(ISA) 0x000001F0 (496)	Microsoft ACPI-Compliant System
	(ISA) 0x000001F1 (497)	Microsoft ACPI-Compliant System
	(ISA) 0x000001F2 (498)	Microsoft ACPI-Compliant System
	(ISA) 0x000001F3 (499)	Microsoft ACPI-Compliant System
	(ISA) 0x000001F4 (500)	Microsoft ACPI-Compliant System
	(ISA) 0x000001F5 (501)	Microsoft ACPI-Compliant System
	(ISA) 0x000001F6 (502)	Microsoft ACPI-Compliant System
	(ISA) 0x000001F7 (503)	Microsoft ACPI-Compliant System
	(ISA) 0x000001F8 (504)	Microsoft ACPI-Compliant System
	(ISA) 0x000001F9 (505)	Microsoft ACPI-Compliant System
	(ISA) 0x000001FA (506)	Microsoft ACPI-Compliant System
	(ISA) 0x000001FB (507)	Microsoft ACPI-Compliant System
	(ISA) 0x000001FC (508)	Microsoft ACPI-Compliant System
	(ISA) 0x000001FD (509)	Microsoft ACPI-Compliant System
	(ISA) 0x000001FE (510)	Microsoft ACPI-Compliant System
	(ISA) 0x000001FF (511)	Microsoft ACPI-Compliant System
	(PCI) 0x0000000B (11)	Intel(R) 100 Series/C230 Series Chipset Family SMBus - A123
	(PCI) 0x00000010 (16)	High Definition Audio Controller
	(PCI) 0x00000010 (16)	Standard SATA AHCI Controller
	(PCI) 0xFFFFFFF8 (-5)	Intel(R) Management Engine Interface
	(PCI) 0xFFFFFFF8 (-4)	Intel(R) USB 3.0 eXtensible Host Controller - 0100 (Microsoft)
	(PCI) 0xFFFFFFF8 (-3)	Intel(R) HD Graphics 530
	(PCI) 0xFFFFFFF8 (-2)	Intel(R) Ethernet Connection (2) I219-LM

▶  Memory

Appendix C

Programming Digital I/O

C.1 Digital I/O Register

Table 1 : Embedded BRAM relative register table		
	Default Value	Note
Index	0x284(Note1)	BRAM Index Register
Data	0x285(Note2)	BRAM Data Register
Logical Device Number	0xA2(Note3)	Watch dog Logical Device Number
Input/Output Function and Device Number	0x00(Note4)	DIO Input/Output Function/Device Number
Output Data Function and Device Number	0x01(Note5)	DIO Output Data Function/Device Number

Table 2 : Digital I/O relative register table				
	Register			
	Option Register	BitNum	Value	Note
GPI0 Pin Status	0x00(Note6)	0(Note7)	(Note15)	GPA2
GPI1 Pin Status	0x00(Note6)	1(Note8)	(Note16)	GPA3
GPI2 Pin Status	0x00(Note6)	2(Note9)	(Note17)	GPA4
GPI3 Pin Status	0x00(Note6)	3(Note10)	(Note18)	GPA5
GPO0 Pin Status	0x00(Note6)	4(Note11)	(Note19)	GPJ0
GPO1 Pin Status	0x00(Note6)	5(Note12)	(Note20)	GPJ1
GPO2 Pin Status	0x00(Note6)	6(Note13)	(Note21)	GPJ2
GPO3 Pin Status	0x00(Note6)	7(Note14)	(Note22)	GPJ3

C.2 Digital I/O Sample Program

```
*****
// Embedded BRAM relative definition (Please reference to Table 1)
#define byte EcBRAMIndex //This parameter is represented from Note1
#define byte EcBRAMData //This parameter is represented from Note2
#define byte BRAMLDNReg //This parameter is represented from Note3
#define byte BRAMFnData0Reg //This parameter is represented from Note4
#define byte BRAMFnData1Reg //This parameter is represented from Note5
#define void EcBRAMWriteByte(byte Offset, byte Value);
#define byte EcBRAMReadByte(byte Offset);
#define void IOWriteByte(byte Offset, byte Value);
#define byte IOReadByte(byte Offset);
// Digital Input Status relative definition (Please reference to Table 2)
#define byte DIO0ToDIO7Reg // This parameter is represented from Note6
#define byte DIO0Bit // This parameter is represented from Note7
#define byte DIO1Bit // This parameter is represented from Note8
#define byte DIO2Bit // This parameter is represented from Note9
#define byte DIO3Bit // This parameter is represented from Note10
#define byte DIO4Bit // This parameter is represented from Note11
#define byte DIO5Bit // This parameter is represented from Note12
#define byte DIO6Bit // This parameter is represented from Note13
#define byte DIO7Bit // This parameter is represented from Note14
#define byte DIO0Val // This parameter is represented from Note15
#define byte DIO1Val // This parameter is represented from Note16
#define byte DIO2Val // This parameter is represented from Note17
#define byte DIO3Val // This parameter is represented from Note18
#define byte DIO4Val // This parameter is represented from Note19
#define byte DIO5Val // This parameter is represented from Note20
#define byte DIO6Val // This parameter is represented from Note21
#define byte DIO7Val // This parameter is represented from Note22
*****
```

```
*****
VOID Main(){
    Boolean PinStatus ;

    // Procedure : AaeonReadPinStatus
    // Input :
    //     Example, Read Digital I/O Pin 3 status
    // Output :
    //     InputStatus :
    //         0: Digital I/O Pin level is low
    //         1: Digital I/O Pin level is High
    PinStatus = AaeonReadPinStatus(DIO0ToDIO7Reg, DIO3Bit);

    // Procedure : AaeonSetOutputLevel
    // Input :
    //     Example, Set Digital I/O Pin 6 level
    AaeonSetOutputLevel(DIO0ToDIO7Reg, DIO6Bit, DIO6Val);
}
*****
```

```
*****
Boolean  AaeonReadPinStatus(byte OptionReg, byte BitNum){
    Byte TempByte;

    TempByte = ECBRAMReadByte(BRAMFnData1Reg, OptionReg);
    If (TempByte & BitNum == 0)
        Return 0;
    Return 1;
}
VOID  AaeonSetOutputLevel(byte OptionReg, byte BitNum, byte Value){
    Byte TempByte;

    TempByte = ECBRAMReadByte(BRAMFnData1Reg, OptionReg);
    TempByte |= (Value << BitNum);
    ECBRAMWriteByte(OptionReg, BitNum, Value);
}
*****
```

```

*****
VOID  ECBRAMWriteByte(byte OPReg, byte OPBit, byte Value){
    IOWriteByte(EcBRAMIndex, 0x10);
    IOWriteByte(EcBRAMData, BRAMLDNReg);
    IOWriteByte(EcBRAMIndex, 0x11);
    IOWriteByte(EcBRAMData, BRAMFnDataReg);

    IOWriteByte(EcBRAMIndex, 0x13 + OPReg);
    IOWriteByte(EcBRAMData, Value);

    IOWriteByte(EcBRAMIndex, 0x12);
    IOWriteByte(EcBRAMData, 0x30);          //Write start
}

Byte  ECBRAMReadByte(byte FnDataReg, byte OPReg){
    IOWriteByte(EcBRAMIndex, 0x10);
    IOWriteByte(EcBRAMData, BRAMLDNReg);
    IOWriteByte(EcBRAMIndex, 0x11);
    IOWriteByte(EcBRAMData, FnDataReg);

    IOWriteByte(EcBRAMIndex, 0x12);
    IOWriteByte(EcBRAMData, 0x10);          //Read start

    IOWriteByte(EcBRAMIndex, 0x13 + OPReg);
    Return    IOReadByte(EcBRAMData, Value);
}
*****

```

Appendix D

Notes for Users

D.1 Notes for Users

Please observe the following items to ensure optimal performance:

1. For applications in 2K/4K resolution, Intel recommends using 2 x DDR4 2133 SODIMM of the size capacity to ensure smooth playback.
2. Always use a new SSD with the latest firmware for optimal performance.
3. With the EHCI controller no longer available on the 6th Gen Intel® Core™ platforms, it is recommended to install Windows 7 through a SATA bus, eg SATA DVD ROM.