

# COM-BT-A30

---

COM Express Module

User's Manual 3<sup>rd</sup> Ed

## Copyright Notice

---

This document is copyrighted, 2019. All rights are reserved. The original manufacturer reserves the right to make improvements to the products described in this manual at any time without notice.

No part of this manual may be reproduced, copied, translated, or transmitted in any form or by any means without the prior written permission of the original manufacturer. Information provided in this manual is intended to be accurate and reliable. However, the original manufacturer assumes no responsibility for its use, or for any infringements upon the rights of third parties that may result from its use.

The material in this document is for product information only and is subject to change without notice. While reasonable efforts have been made in the preparation of this document to assure its accuracy, AAEMON assumes no liabilities resulting from errors or omissions in this document, or from the use of the information contained herein.

AAEMON reserves the right to make changes in the product design without notice to its users.

## Acknowledgement

---

All other products' name or trademarks are properties of their respective owners.

- Microsoft Windows is a registered trademark of Microsoft Corp.
- Intel, Pentium, Celeron, and Xeon are registered trademarks of Intel Corporation
- Core, Atom are trademarks of Intel Corporation
- ITE is a trademark of Integrated Technology Express, Inc.
- IBM, PC/AT, PS/2, and VGA are trademarks of International Business Machines Corporation.

All other product names or trademarks are properties of their respective owners.

## Packing List

---

Before setting up your product, please make sure the following items have been shipped:

Item	Quantity
● COM-BT-A30	1

If any of these items are missing or damaged, please contact your distributor or sales representative immediately.

## About this Document

---

This User's Manual contains all the essential information, such as detailed descriptions and explanations on the product's hardware and software features (if any), its specifications, dimensions, jumper/connector settings/definitions, and driver installation instructions (if any), to facilitate users in setting up their product.

Users may refer to the [AAEON.com](http://AAEON.com) for the latest version of this document.

## Safety Precautions

---

Please read the following safety instructions carefully. It is advised that you keep this manual for future references

1. All cautions and warnings on the device should be noted.
2. Make sure the power source matches the power rating of the device.
3. Position the power cord so that people cannot step on it. Do not place anything over the power cord.
4. Always completely disconnect the power before working on the system's hardware.
5. No connections should be made when the system is powered as a sudden rush of power may damage sensitive electronic components.
6. If the device is not to be used for a long time, disconnect it from the power supply to avoid damage by transient over-voltage.
7. Always disconnect this device from any AC supply before cleaning.
8. While cleaning, use a damp cloth instead of liquid or spray detergents.
9. Make sure the device is installed near a power outlet and is easily accessible.
10. Keep this device away from humidity.
11. Place the device on a solid surface during installation to prevent falls
12. Do not cover the openings on the device to ensure optimal heat dissipation.
13. Watch out for high temperatures when the system is running.
14. Do not touch the heat sink or heat spreader when the system is running
15. Never pour any liquid into the openings. This could cause fire or electric shock.
16. As most electronic components are sensitive to static electrical charge, be sure to ground yourself to prevent static charge when installing the internal components. Use a grounding wrist strap and contain all electronic components in any static-shielded containers.

17. If any of the following situations arises, please the contact our service personnel:
  - i. Damaged power cord or plug
  - ii. Liquid intrusion to the device
  - iii. Exposure to moisture
  - iv. Device is not working as expected or in a manner as described in this manual
  - v. The device is dropped or damaged
  - vi. Any obvious signs of damage displayed on the device
18. **DO NOT LEAVE THIS DEVICE IN AN UNCONTROLLED ENVIRONMENT WITH TEMPERATURES BEYOND THE DEVICE'S PERMITTED STORAGE TEMPERATURES (SEE CHAPTER 1) TO PREVENT DAMAGE.**

### **Warning!**



This device complies with Part 15 FCC Rules. Operation is subject to the following two conditions: (1) this device may not cause harmful interference, and (2) this device must accept any interference received including interference that may cause undesired operation.

### **Caution:**

*There is a danger of explosion if the battery is incorrectly replaced. Replace only with the same or equivalent type recommended by the manufacturer. Dispose of used batteries according to the manufacturer's instructions and your local government's recycling or disposal directives.*

### **Attention:**

*Il y a un risque d'explosion si la batterie est remplacée de façon incorrecte. Ne la remplacer qu'avec le même modèle ou équivalent recommandé par le constructeur. Recycler les batteries usées en accord avec les instructions du fabricant et les directives gouvernementales de recyclage.*



## China RoHS Requirements (CN)

产品中有毒有害物质或元素名称及含量

AAEON Main Board/ Daughter Board/ Backplane

部件名称	有毒有害物质或元素					
	铅 (Pb)	汞 (Hg)	镉 (Cd)	六价铬 (Cr(VI))	多溴联苯 (PBB)	多溴二苯醚 (PBDE)
印刷电路板 及其电子组件	○	○	○	○	○	○
外部信号 连接器及线材	○	○	○	○	○	○
<p>O: 表示该有毒有害物质在该部件所有均质材料中的含量均在 SJ/T 11363-2006 标准规定的限量要求以下。</p> <p>X: 表示该有毒有害物质至少在该部件的某一均质材料中的含量超出 SJ/T 11363-2006 标准规定的限量要求。</p> <p>备注: 此产品所标示之环保使用期限, 系指在一般正常使用状况下。</p>						

## China RoHS Requirement (EN)

Poisonous or Hazardous Substances or Elements in Products

AAEON Main Board/ Daughter Board/ Backplane

Component	Poisonous or Hazardous Substances or Elements					
	Lead (Pb)	Mercury (Hg)	Cadmium (Cd)	Hexavalent Chromium (Cr(VI))	Polybrominated Biphenyls (PBB)	Polybrominated Diphenyl Ethers (PBDE)
PCB & Other Components	○	○	○	○	○	○
Wires & Connectors for External Connections	○	○	○	○	○	○
<p>O: The quantity of poisonous or hazardous substances or elements found in each of the component's parts is below the SJ/T 11363-2006-stipulated requirement.</p> <p>X: The quantity of poisonous or hazardous substances or elements found in at least one of the component's parts is beyond the SJ/T 11363-2006-stipulated requirement.</p> <p><b>Note:</b> The Environment Friendly Use Period as labeled on this product is applicable under normal usage only</p>						

# Table of Contents

---

<b>Chapter 1 - Product Specifications</b> .....	<b>1</b>
1.1 Specifications .....	2
<b>Chapter 2 – Hardware Information</b> .....	<b>4</b>
2.1 Dimensions .....	5
2.2 Jumpers and Connectors.....	7
2.3 List of Connectors.....	9
2.3.1 Carrier Board DP/HDMI Function, LVDS Function, AT & ATX Mode, RCT Rest Setting (SW1).....	10
2.3.2 COM Express ROW A/B Connector (CN1).....	10
2.3.3 COM Express ROW C/D Connector (CN2).....	19
2.3.4 SPI Connector (CN5).....	27
2.3.5 LPC Connector (CN6) .....	28
<b>Chapter 3 - AMI BIOS Setup</b> .....	<b>29</b>
3.1 System Test and Initialization .....	30
3.2 AMI BIOS Setup .....	31
3.3 Setup submenu: Main .....	32
3.4 Setup submenu: Advanced .....	33
3.4.1 Advanced: CPU Configuration .....	34
3.4.2 Advanced: IDE Configuration.....	35
3.4.3 Advanced: USB Configuration .....	36
3.4.4 Advanced: On-Module H/W Monitor .....	38
3.4.4.1 CPU Smart Fan control: Full mode .....	39
3.4.4.2 CPU Smart Fan control: Manual Mode by PWM.....	40
3.4.4.3 CPU Smart Fan control: Auto Mode by PWM .....	41
3.4.5 Advanced: Dynamic Digital IO Configuration .....	43
3.4.6 Advanced: Power Management .....	44

3.4.7	Advanced: Trusted Computing .....	46
3.4.8	Advanced: SIO Configuration .....	49
3.4.8.1	Serial Port 9 Configuration .....	50
3.4.8.2	Serial Port 10 Configuration .....	51
3.5	Setup submenu: Chipset .....	52
3.5.1	Chipset: North Bridge .....	53
3.5.1.1	North Bridge: Display Control Configuration .....	54
3.5.2	Chipset: South Bridge .....	57
3.6	Setup submenu: Security .....	58
3.7	Setup submenu: Boot .....	59
3.7.1	BBS Priorities .....	60
3.8	Setup submenu: Save & Exit .....	61
<b>Chapter 4 – Drivers Installation .....</b>		<b>62</b>
4.1	Driver Download/Installation .....	63
<b>Appendix A - Watchdog Timer Programming .....</b>		<b>65</b>
A.1	Watchdog Timer Initial Program .....	66
<b>Appendix B –I/O Information .....</b>		<b>71</b>
B.1	I/O Address Map .....	72
B.2	Memory Address Map .....	73
B.3	IRQ Mapping Chart .....	73
<b>Appendix C – Programming Digital I/O .....</b>		<b>80</b>
C.1	DIO Programming .....	81
C.2	Digital I/O Register .....	82
C.3	Digital I/O Sample Program .....	83

# Chapter 1

---

Product Specifications

## 1.1 Specifications

---

### System

Form Factor	COM Express, Compact, Pin-out Type 6
CPU	Onboard Intel® Atom™ SoC
CPU Frequency	Intel® Atom™ N2930 (1.83 GHz) N2807 (1.58 GHz) E3845 (1.91 GHz) E3827 (1.75 GHz) E3825 (1.33 GHz) J1900 (2.0 GHz)
Chipset	Intel® Atom™ SoC
Memory Type	DDR3L 1066/1333 MHz SODIMM x 1
Max. Memory Capacity	8 GB
BIOS	AMI BIOS
Wake on LAN	Yes
Watchdog Timer	255 Levels
Power Requirement	Nominal: +12V
Power Supply Type	AT/ ATX
Power Consumption (Typical)	0.92A@12V, full load, J1900 0.48A@12V, full load, N2807
Dimension (L x W)	3.74" x 3.74" (95mm x 95mm)
Operating Temperature	32°F ~ 140°F (0°C ~ 60°C) -40°F ~ 185°F (-40°C ~ 85°C) optional

## System

Storage Temperature	-40°F ~ 176°F (-40°C ~ 80°C)
Operating Humidity	0% ~ 90% relative humidity, non-condensing
MTBF (Hours)	80,000
Certification	CE/FCC

## Display

VGA/LCD Controller	Intel® Atom™ SoC Integrated
Video Output	CRT, LVDS LCD, DDI

## I/O

Ethernet	Intel® I211, Gigabit Ethernet
Audio	High Definition Audio Interface
USB Port	USB 2.0 x 7, USB 3.0 x 1
Serial Port	Tx/Rx x 2
HDD Interface	SATA x 2
SSD	—
Expansion Slot	PCI-Express[x1] x 3 (Gen 2.0) LPC Bus x 1 SMBus x 1
GPIO	GPIO 8-bit
TPM	—

# Chapter 2

---

Hardware Information



## 2.1 Dimensions

### Component Side

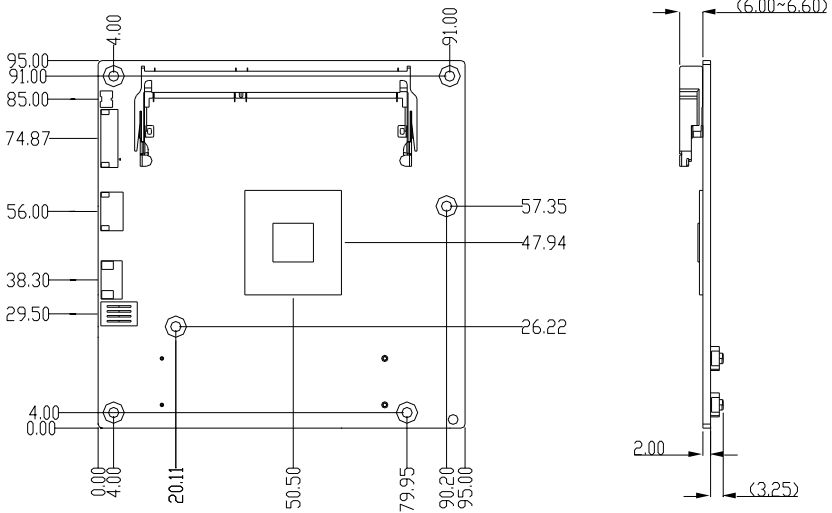

## Solder Side

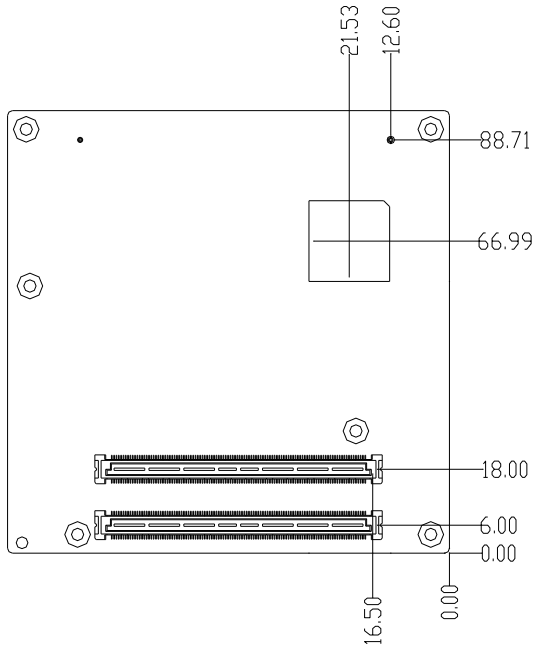

## With Heat spreader

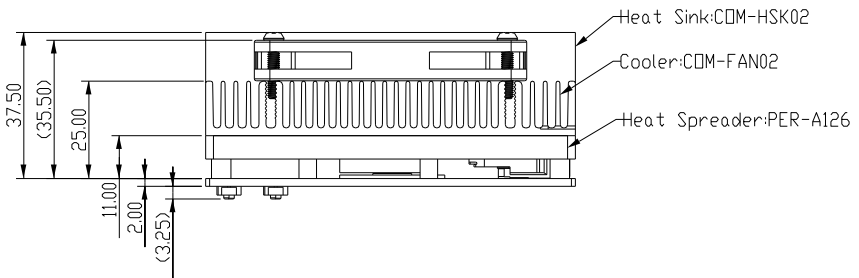

## 2.2 Jumpers and Connectors

### Component Side

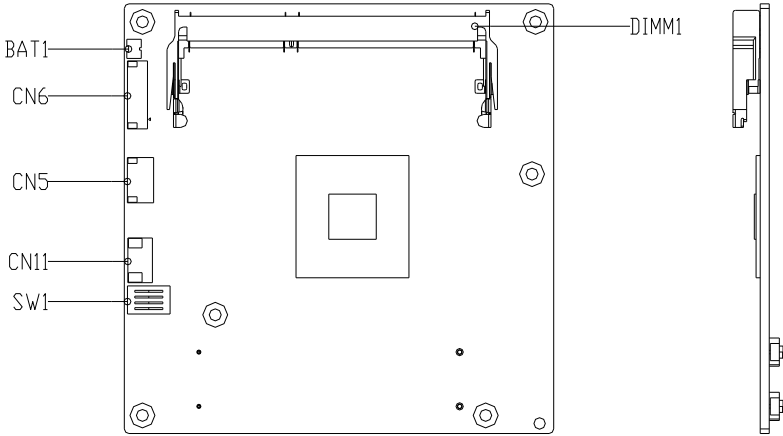

# Solder Side

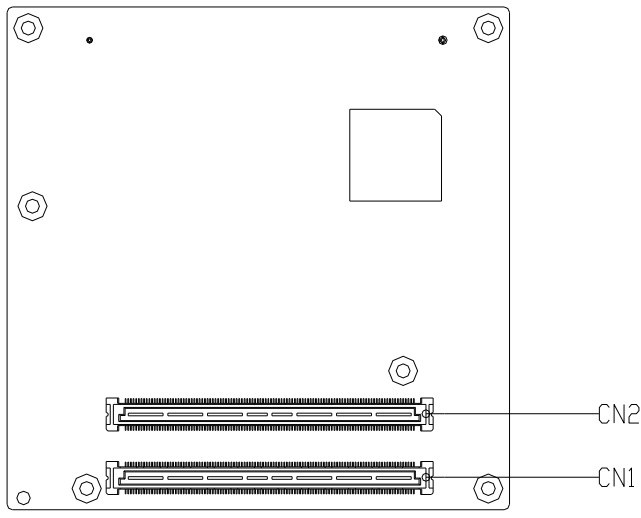

## 2.3 List of Connectors

---

Please refer to the table below for all of the board's jumpers that you can configure for your application

Label	Function
SW1	1. Carrier Board DP/HDMI Function 2. LVDS Function 3. AT & ATX mode 4. RCT Rest setting
BAT1	RTC Battery
CN1	ROW A/B
CN2	ROW C/D
CN5	SPI Connector
CN6	LPC Connector
DIMM1	DDR3L Socket

### 2.3.1 Carrier Board DP/HDMI Function, LVDS Function, AT & ATX Mode, RCT Rest Setting (SW1)

	OFF	ON
1	DP/HDMI[1](Default)	eDP on MB(Optional)
2	DP/HDMI[2](Optional)	LVDS(Default)
3	ATX (Default)	AT
4	Normal(Default)	Clear CMOS

### 2.3.2 COM Express ROW A/B Connector (CN1)

#### Row A

Pin	COMe 2.1 SPEC Type 6	COM-BT Signal
A1	GND	GND
A2	GBE0_MDI3-	GBE0_MDI3-
A3	GBE0_MDI3+	GBE0_MDI3+
A4	GBE0_LNIK100#	GBE0_LNIK100#
A5	GBE0_LNIK1000#	GBE0_LNIK1000#
A6	GBE0_MDI2-	GBE0_MDI2-
A7	GBE0_MDI2+	GBE0_MDI2+
A8	GBE0_LINK#	GBE0_LINK#
A9	GBE0_MDI1-	GBE0_MDI1-
A10	GBE0_MDI1+	GBE0_MDI1+
A11	GND	GND
A12	GBE0_MDI0-	GBE0_MDI0-
A13	GBE0_MDI0+	GBE0_MDI0+
A14	GBE0_CTREF	GBE0_CTREF

A15	SUS_S3#	SUS_S3#
A16	SATA0_TX+	SATA0_TX+
A17	SATA0_TX-	SATA0_TX-
A18	SUS_S4#	SUS_S4#
A19	SATA0_RX+	SATA0_RX+
A20	SATA0_RX-	SATA0_RX-
A21	GND	GND
A22	SATA2_TX+	NC
A23	SATA2_TX-	NC
A24	SUS_S5#	SUS_S5#
A25	SATA2_RX+	NC
A26	SATA2_RX-	NC
A27	BATLOW#	BATLOW#
A28	(S)ATA_ACT#	(S)ATA_ACT#
A29	AC/HDA_SYNC	AC/HDA_SYNC
A30	AC/HDA_RST#	AC/HDA_RST#
A31	GND	GND
A32	AC/HDA_BITCLK	AC/HDA_BITCLK
A33	AC/HDA_SDOOUT	AC/HDA_SDOOUT
A34	BIOS_DIS0#	BIOS_DIS0#
A35	THRMTRIP#	THRMTRIP#
A36	USB6-	USB6-
A37	USB6+	USB6+
A38	USB_6_7_OC#	USB_6_7_OC#
A39	USB4-	USB4-
A40	USB4+	USB4+
A41	GND	GND

A42	USB2-	USB2-
A43	USB2+	USB2+
A44	USB_2_3_OC#	USB_2_3_OC#
A45	USB0-	USB0-
A46	USB0+	USB0+
A47	VCC_RTC	VCC_RTC
A48	EXCD0_PERST#	EXCD0_PERST#
A49	EXCD0_CPPE#	EXCD0_CPPE#
A50	LPC_SERIRQ	LPC_SERIRQ
A51	GND	GND
A52	PCIE_TX5+	NC
A53	PCIE_TX5-	NC
A54	GPI0	GPI0
A55	PCIE_TX4+	NC
A56	PCIE_TX4-	NC
A57	GND	GND
A58	PCIE_TX3+	PCIE_TX3+
A59	PCIE_TX3-	PCIE_TX3-
A60	GND	GND
A61	PCIE_TX2+	PCIE_TX2+
A62	PCIE_TX2-	PCIE_TX2-
A63	GPI1	GPI1
A64	PCIE_TX1+	PCIE_TX1+
A65	PCIE_TX1-	PCIE_TX1-
A66	GND	GND
A67	GPI2	GPI2
A68	PCIE_TX0+	PCIE_TX0+



A69	PCIE_TX0-	PCIE_TX0-
A70	GND	GND
A71	LVDS_A0+	LVDS_A0+
A72	LVDS_A0-	LVDS_A0-
A73	LVDS_A1+	LVDS_A1+
A74	LVDS_A1-	LVDS_A1-
A75	LVDS_A2+	LVDS_A2+
A76	LVDS_A2-	LVDS_A2-
A77	LVDS_VDD_EN	LVDS_VDD_EN
A78	LVDS_A3+	LVDS_A3+
A79	LVDS_A3-	LVDS_A3-
A80	GND	GND
A81	LVDS_A_CK+	LVDS_A_CK+
A82	LVDS_A_CK-	LVDS_A_CK-
A83	LVDS_I2C_CK	LVDS_I2C_CK
A84	LVDS_I2C_DAT	LVDS_I2C_DAT
A85	GPI3	GPI3
A86	RSVD	NC
A87	RSVD	NC
A88	PCIE_CLK_REF+	PCIE_CLK_REF+
A89	PCIE_CLK_REF-	PCIE_CLK_REF-
A90	GND	GND
A91	SPI_POWER	SPI_POWER
A92	SPI_MISO	SPI_MISO
A93	GPO0	GPO0
A94	SPI_CLK	SPI_CLK
A95	SPI_MOSI	SPI_MOSI

A96	TPM_PP	TPM_PP
A97	TYPE10#	NC
A98	SER0_TX	SER0_TX
A99	SER0_RX	SER0_RX
A100	GND	GND
A101	SER1_TX	SER1_TX
A102	SER1_RX	SER1_RX
A103	LID#	LID#
A104	VCC_12V	VCC_12V
A105	VCC_12V	VCC_12V
A106	VCC_12V	VCC_12V
A107	VCC_12V	VCC_12V
A108	VCC_12V	VCC_12V
A109	VCC_12V	VCC_12V
A110	GND	GND

## Row B

Pin	COMe 2.1 SPEC Type 6	COM-BT Signal
B1	GND	GND
B2	GBE0_ACT#	GBE0_ACT#
B3	LPC_FRAME#	LPC_FRAME#
B4	LPC_AD0	LPC_AD0
B5	LPC_AD1	LPC_AD1
B6	LPC_AD2	LPC_AD2
B7	LPC_AD3	LPC_AD3
B8	LPC_DRQ0#	NC
B9	LPC_DRQ1#	NC

B10	LPC_CLK	LPC_CLK
B11	GND	GND
B12	PWRBTN#	PWRBTN#
B13	SMB_CK	SMB_CK
B14	SMB_DAT	SMB_DAT
B15	SMB_ALERT#	SMB_ALERT#
B16	SATA1_TX+	SATA1_TX+
B17	SATA1_TX-	SATA1_TX-
B18	SUS_STAT#	SUS_STAT#
B19	SATA1_RX+	SATA1_RX+
B20	SATA1_RX-	SATA1_RX-
B21	GND	GND
B22	SATA3_TX+	NC
B23	SATA3_TX-	NC
B24	PWR_OK	PWR_OK
B25	SATA3_RX+	NC
B26	SATA3_RX-	NC
B27	WDT	WDT
B28	AC/HDA_SDIN2	AC/HDA_SDIN2
B29	AC/HDA_SDIN1	AC/HDA_SDIN1
B30	AC/HDA_SDIN0	AC/HDA_SDIN0
B31	GND	GND
B32	SPKR	SPKR
B33	I2C_CK	I2C_CK
B34	I2C_DAT	I2C_DAT
B35	THRM#	THRM#
B36	USB7-	NC

B37	USB7+	NC
B38	USB_4_5_OC#	USB_4_5_OC#
B39	USB5-	USB5-
B40	USB5+	USB5+
B41	GND	GND
B42	USB3-	USB3-
B43	USB3+	USB3+
B44	USB_0_1_OC#	USB_0_1_OC#
B45	USB1-	USB1-
B46	USB1+	USB1+
B47	EXCD1_PERST#	EXCD1_PERST#
B48	EXCD1_CPPE#	EXCD1_CPPE#
B49	SYS_RESET#	SYS_RESET#
B50	CB_RESET#	CB_RESET#
B51	GND	GND
B52	PCIE_RX5+	NC
B53	PCIE_RX5-	NC
B54	GPO1	GPO1
B55	PCIE_RX4+	NC
B56	PCIE_RX4-	NC
B57	GPO2	GPO2
B58	PCIE_RX3+	PCIE_RX3+
B59	PCIE_RX3-	PCIE_RX3-
B60	GND	GND
B61	PCIE_RX2+	PCIE_RX2+
B62	PCIE_RX2-	PCIE_RX2-
B63	GPO3	GPO3

B64	PCIE_RX1+	PCIE_RX1+
B65	PCIE_RX1-	PCIE_RX1-
B66	WAKE0#	WAKE0#
B67	WAKE1#	WAKE1#
B68	PCIE_RX0+	PCIE_RX0+
B69	PCIE_RX0-	PCIE_RX0-
B70	GND	GND
B71	LVDS_B0+	LVDS_B0+
B72	LVDS_B0-	LVDS_B0-
B73	LVDS_B1+	LVDS_B1+
B74	LVDS_B1-	LVDS_B1-
B75	LVDS_B2+	LVDS_B2+
B76	LVDS_B2-	LVDS_B2-
B77	LVDS_B3+	LVDS_B3+
B78	LVDS_B3-	LVDS_B3-
B79	LVDS_BKLT_EN	LVDS_BKLT_EN
B80	GND	GND
B81	LVDS_B_CK+	LVDS_B_CK+
B82	LVDS_B_CK-	LVDS_B_CK-
B83	LVDS_BKLT_CTRL	LVDS_BKLT_CTRL
B84	VCC_5V_SBY	VCC_5V_SBY
B85	VCC_5V_SBY	VCC_5V_SBY
B86	VCC_5V_SBY	VCC_5V_SBY
B87	VCC_5V_SBY	VCC_5V_SBY
B88	BIOS_DIS1#	BIOS_DIS1#
B89	VGA_RED	VGA_RED
B90	GND	GND

B91	VGA_GRN	VGA_GRN
B92	VGA_BLU	VGA_BLU
B93	VGA_HSYNC	VGA_HSYNC
B94	VGA_VSYNC	VGA_VSYNC
B95	VGA_I2C_CK	VGA_I2C_CK
B96	VGA_I2C_DAT	VGA_I2C_DAT
B97	SPI_CS#	SPI_CS#
B98	RSVD	SMI#
B99	RSVD	SCI#
B100	GND	GND
B101	FAN_PWMOUT	FAN_PWMOUT
B102	FAN_TACHIN	FAN_TACHIN
B103	SLEEP#	SLEEP#
B104	VCC_12V	VCC_12V
B105	VCC_12V	VCC_12V
B106	VCC_12V	VCC_12V
B107	VCC_12V	VCC_12V
B108	VCC_12V	VCC_12V
B109	VCC_12V	VCC_12V
B110	GND	GND

### 2.3.3 COM Express ROW C/D Connector (CN2)

#### Row C

Pin	COMe 2.1 SPEC Type 6	COM-BT Signal
C1	GND	GND
C2	GND	GND
C3	USB_SSRX0-	USB_SSRX0-
C4	USB_SSRX0+	USB_SSRX0+
C5	GND	GND
C6	USB_SSRX1-	NC
C7	USB_SSRX1+	NC
C8	GND	GND
C9	USB_SSRX2-	NC
C10	USB_SSRX2+	NC
C11	GND	GND
C12	USB_SSRX3-	NC
C13	USB_SSRX3+	NC
C14	GND	GND
C15	DDI1_PAIR6+	NC
C16	DDI1_PAIR6-	NC
C17	RSVD	NC
C18	RSVD	NC
C19	PCIE_RX6+	NC
C20	PCIE_RX6-	NC
C21	GND	GND
C22	PCIE_RX7+	NC
C23	PCIE_RX7-	NC

C24	DDI1_HPD	DDI1_HPD
C25	DDI1_PAIR4+	NC
C26	DDI1_PAIR4-	NC
C27	RSVD	NC
C28	RSVD	NC
C29	DDI1_PAIR5+	NC
C30	DDI1_PAIR5-	NC
C31	GND	GND
C32	DDI2_CTRLCLK_AUX+	DDI2_CTRLCLK_AUX+
C33	DDI2_CTRLDATA_AUX-	DDI2_CTRLDATA_AUX-
C34	DDI2_DDC_AUX_SEL	DDI2_DDC_AUX_SEL
C35	RSVD	NC
C36	DDI3_CTRLCLK_AUX+	NC
C37	DDI3_CTRLDATA_AUX-	NC
C38	DDI3_DDC_AUX_SEL	NC
C39	DDI3_PAIR0+	NC
C40	DDI3_PAIR0-	NC
C41	GND	GND
C42	DDI3_PAIR1+	NC
C43	DDI3_PAIR1-	NC
C44	DDI3_HPD	NC
C45	RSVD	NC
C46	DDI3_PAIR2+	NC
C47	DDI3_PAIR2-	NC
C48	RSVD	NC
C49	DDI3_PAIR3+	NC
C50	DDI3_PAIR3-	NC



C51	GND	GND
C52	PEG_RX0+	NC
C53	PEG_RX0-	NC
C54	TYPE0#	NC
C55	PEG_RX1+	NC
C56	PEG_RX1-	NC
C57	TYPE1#	NC
C58	PEG_RX2+	NC
C59	PEG_RX2-	NC
C60	GND	GND
C61	PEG_RX3+	NC
C62	PEG_RX3-	NC
C63	RSVD	NC
C64	RSVD	NC
C65	PEG_RX4+	NC
C66	PEG_RX4-	NC
C67	RSVD	NC
C68	PEG_RX5+	NC
C69	PEG_RX5-	NC
C70	GND	GND
C71	PEG_RX6+	NC
C72	PEG_RX6-	NC
C73	GND	GND
C74	PEG_RX7+	NC
C75	PEG_RX7-	NC
C76	GND	GND
C77	RSVD	NC

C78	PEG_RX8+	NC
C79	PEG_RX8-	NC
C80	GND	GND
C81	PEG_RX9+	NC
C82	PEG_RX9-	NC
C83	RSVD	NC
C84	GND	GND
C85	PEG_RX10+	NC
C86	PEG_RX10-	NC
C87	GND	GND
C88	PEG_RX11+	NC
C89	PEG_RX11-	NC
C90	GND	GND
C91	PEG_RX12+	NC
C92	PEG_RX12-	NC
C93	GND	GND
C94	PEG_RX13+	NC
C95	PEG_RX13-	NC
C96	GND	GND
C97	RSVD	NC
C98	PEG_RX14+	NC
C99	PEG_RX14-	NC
C100	GND	GND
C101	PEG_RX15+	NC
C102	PEG_RX15-	NC
C103	GND	GND
C104	VCC_12V	VCC_12V

C105	VCC_12V	VCC_12V
C106	VCC_12V	VCC_12V
C107	VCC_12V	VCC_12V
C108	VCC_12V	VCC_12V
C109	VCC_12V	VCC_12V
C110	GND	GND

## Row D

Pin	COMe 2.1 SPEC Type 6	COM-BT Signal
D1	GND	GND
D2	GND	GND
D3	USB_SSTX0-	USB_SSTX0-
D4	USB_SSTX0+	USB_SSTX0+
D5	GND	GND
D6	USB_SSTX1-	NC
D7	USB_SSTX1+	NC
D8	GND	GND
D9	USB_SSTX2-	NC
D10	USB_SSTX2+	NC
D11	GND	GND
D12	USB_SSTX3-	NC
D13	USB_SSTX3+	NC
D14	GND	GND
D15	DDI1_CTRLCLK_AUX+	DDI1_CTRLCLK_AUX+
D16	DDI1_CTRLCLK_AUX-	DDI1_CTRLCLK_AUX-
D17	RSVD	NC
D18	RSVD	NC

D19	PCIE_TX6+	NC
D20	PCIE_TX6-	NC
D21	GND	GND
D22	PCIE_TX7+	NC
D23	PCIE_TX7-	NC
D24	RSVD	NC
D25	RSVD	NC
D26	DDI1_PAIR0+	DDI1_PAIR0+
D27	DDI1_PAIR0-	DDI1_PAIR0-
D28	RSVD	NC
D29	DDI1_PAIR1+	DDI1_PAIR1+
D30	DDI1_PAIR1-	DDI1_PAIR1-
D31	GND	GND
D32	DDI1_PAIR2+	DDI1_PAIR2+
D33	DDI1_PAIR2-	DDI1_PAIR2-
D34	DDI1_DDC_AUX_SEL	DDI1_DDC_AUX_SEL
D35	RSVD	NC
D36	DDI1_PAIR3+	DDI1_PAIR3+
D37	DDI1_PAIR3-	DDI1_PAIR3-
D38	RSVD	NC
D39	DDI2_PAIR0+	DDI2_PAIR0+
D40	DDI2_PAIR0-	DDI2_PAIR0-
D41	GND	GND
D42	DDI2_PAIR1+	DDI2_PAIR1+
D43	DDI2_PAIR1-	DDI2_PAIR1-
D44	DDI2_HPD	DDI2_HPD
D45	RSVD	NC

D46	DDI2_PAIR2+	DDI2_PAIR2+
D47	DDI2_PAIR2-	DDI2_PAIR2-
D48	RSVD	NC
D49	DDI2_PAIR3+	DDI2_PAIR3+
D50	DDI2_PAIR3-	DDI2_PAIR3-
D51	GND	GND
D52	PEG_TX0+	NC
D53	PEG_TX0-	NC
D54	PEG_LANE_RV#	NC
D55	PEG_TX1+	NC
D56	PEG_TX1-	NC
D57	TYPE2#	TYPE2#
D58	PEG_TX2+	NC
D59	PEG_TX2-	NC
D60	GND	GND
D61	PEG_TX3+	NC
D62	PEG_TX3-	NC
D63	RSVD	NC
D64	RSVD	NC
D65	PEG_TX4+	NC
D66	PEG_TX4-	NC
D67	GND	GND
D68	PEG_TX5+	NC
D69	PEG_TX5-	NC
D70	GND	GND
D71	PEG_TX6+	NC
D72	PEG_TX6-	NC

D73	GND	GND
D74	PEG_TX7+	NC
D75	PEG_TX7-	NC
D76	GND	GND
D77	RSVD	NC
D78	PEG_TX8+	NC
D79	PEG_TX8-	NC
D80	GND	GND
D81	PEG_TX9+	NC
D82	PEG_TX9-	NC
D83	RSVD	NC
D84	GND	GND
D85	PEG_TX10+	NC
D86	PEG_TX10-	NC
D87	GND	GND
D88	PEG_TX11+	NC
D89	PEG_TX11-	NC
D90	GND	GND
D91	PEG_TX12+	NC
D92	PEG_TX12-	NC
D93	GND	GND
D94	PEG_TX13+	NC
D95	PEG_TX13-	NC
D96	GND	GND
D97	RSVD	NC
D98	PEG_TX14+	NC
D99	PEG_TX14-	NC

D100	GND	GND
D101	PEG_TX15+	NC
D102	PEG_TX15-	NC
D103	GND	GND
D104	VCC_12V	VCC_12V
D105	VCC_12V	VCC_12V
D106	VCC_12V	VCC_12V
D107	VCC_12V	VCC_12V
D108	VCC_12V	VCC_12V
D109	VCC_12V	VCC_12V
D110	GND	GND

### 2.3.4 SPI Connector (CN5)

Pin	Signal	Pin	Signal
1	SPI_SO_F	5	SPI_SI_F
2	GND	6	SPI_CE0#_F
3	SPI_CLK_F	7	SPI_CE1#_F
4	+V3.3A_SPI		

### 2.3.5 LPC Connector (CN6)

---

Pin	Signal	Pin	Signal
1	LPC_AD0	7	BUF_PLT_RST#
2	LPC_AD1	8	GND
3	LPC_AD2	9	PCI_CLK_SIO
4	LPC_AD3	10	NC
5	+V3.3S	11	NC
6	LPC_FRAME#	12	INT_SERIRQ



# Chapter 3

---

AMI BIOS Setup

## 3.1 System Test and Initialization

---

These routines test and initialize board hardware. If the routines encounter an error during the tests, you will either hear a few short beeps or see an error message on the screen. There are two kinds of errors: fatal and non-fatal. The system can usually continue the boot up sequence with non-fatal errors.

### System configuration verification

These routines check the current system configuration stored in the CMOS memory and BIOS NVRAM. If system configuration is not found or system configuration data error is detected, system will load optimized default and re-boot with this default system configuration automatically.

There are four situations in which you will need to setup system configuration:

1. You are starting your system for the first time
2. You have changed the hardware attached to your system
3. The system configuration is reset by Clear-CMOS jumper
4. The CMOS memory has lost power and the configuration information has been erased.

The COM-BT-A30 CMOS memory has an integral lithium battery backup for data retention. However, you will need to replace the complete unit when it finally runs down.

## 3.2 AMI BIOS Setup

---

AMI BIOS ROM has a built-in Setup program that allows users to modify the basic system configuration. This type of information is stored in battery-backed CMOS RAM and BIOS NVRAM so that it retains the Setup information when the power is turned off.

### Entering Setup

Power on the computer and press <Del> or <ESC> immediately. This will allow you to enter Setup.

**Main** – Date and time can be set here. Press <Tab> to switch between date elements

**Advanced** – Enable/ Disable boot option for legacy network devices

**Chipset** – For hosting bridge parameters

**Boot** – Enable/ Disable quiet Boot Option

**Security** – The setup administrator password can be set here

**Save & Exit** – Save your changes and exit the program

### 3.3 Setup submenu: Main

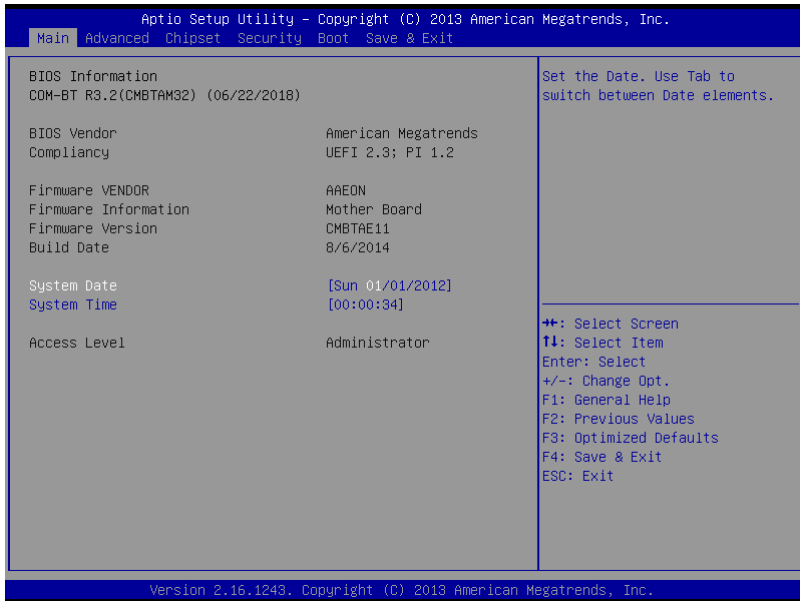

### 3.4 Setup submenu: Advanced

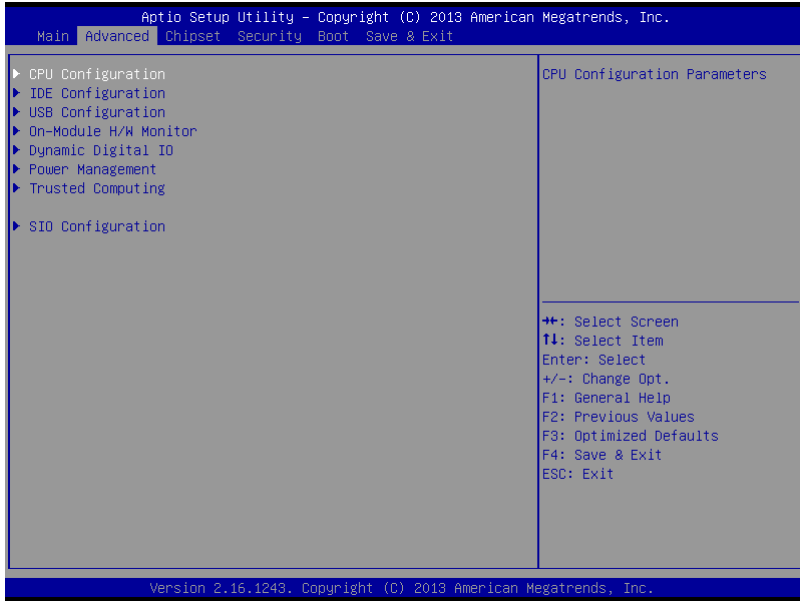

### 3.4.1 Advanced: CPU Configuration

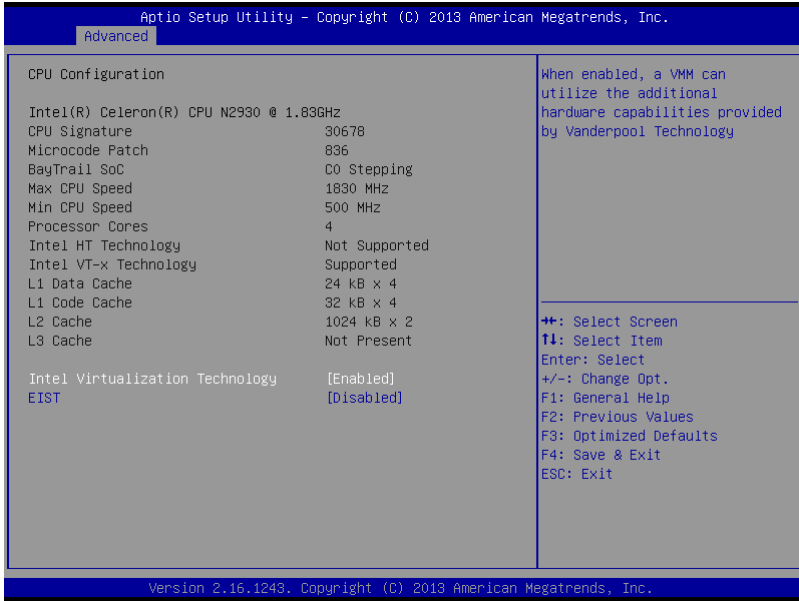

Options summary:

Intel Virtualization Technology	Disabled	
	Enabled	Optimal Default, Failsafe Default
When enabled, a VMM can utilize the additional hardware capabilities provided by Vanderpool Technology.		
EIST	Disabled	
	Enabled	Optimal Default, Failsafe Default
Enable/Disable Intel SpeedStep.		

### 3.4.2 Advanced: IDE Configuration

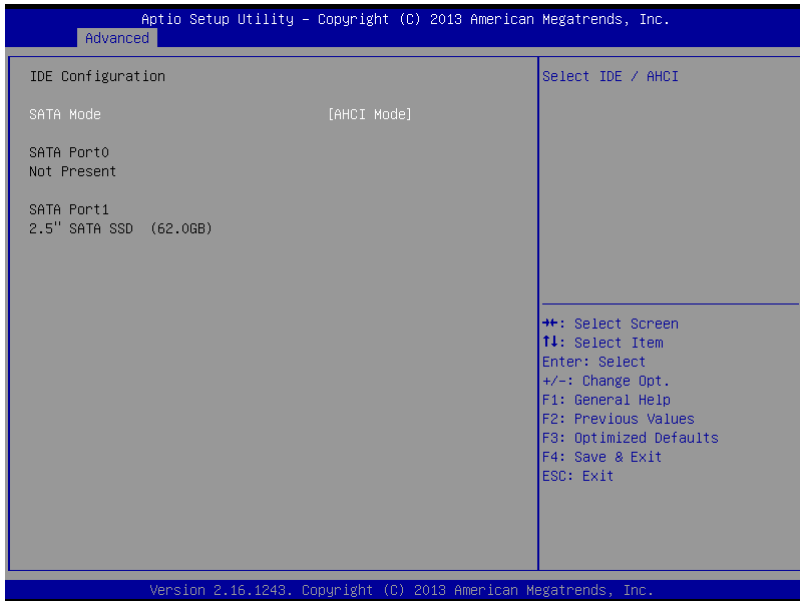

Options summary:

SATA Mode	IDE Mode	
	AHCI Mode	Optimal Default, Failsafe Default
Select IDE / AHCI.		

### 3.4.3 Advanced: USB Configuration

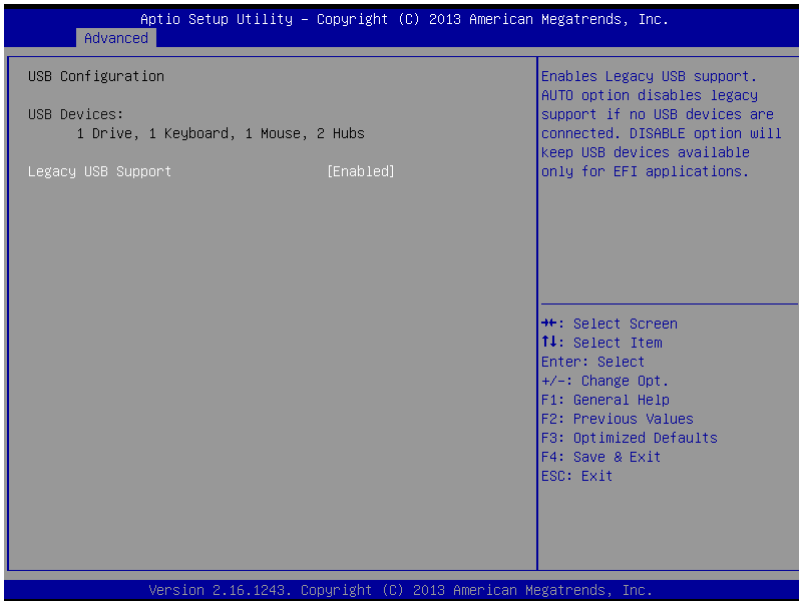

Options summary:

Legacy USB Support	Enabled	Optimal Default, Failsafe Default
	Disabled	
	Auto	
<p>Enables Legacy USB support.          AUTO option disables legacy support if no USB devices are connected. DISABLE option will keep USB devices available only for EFI applications.</p>		
Device Name (Emulation Type)	Auto	Optimal Default, Failsafe Default
	Floppy	
	Forced FDD	
	Hard Disk	
	CDROM	



If Auto. USB devices less than 530MB will be emulated as Floppy and remaining as Floppy and remaining as hard drive. Forced FDD option can be used to force a HDD formatted drive to boot as FDD(Ex. ZIP drive)

### 3.4.4 Advanced: On-Module H/W Monitor

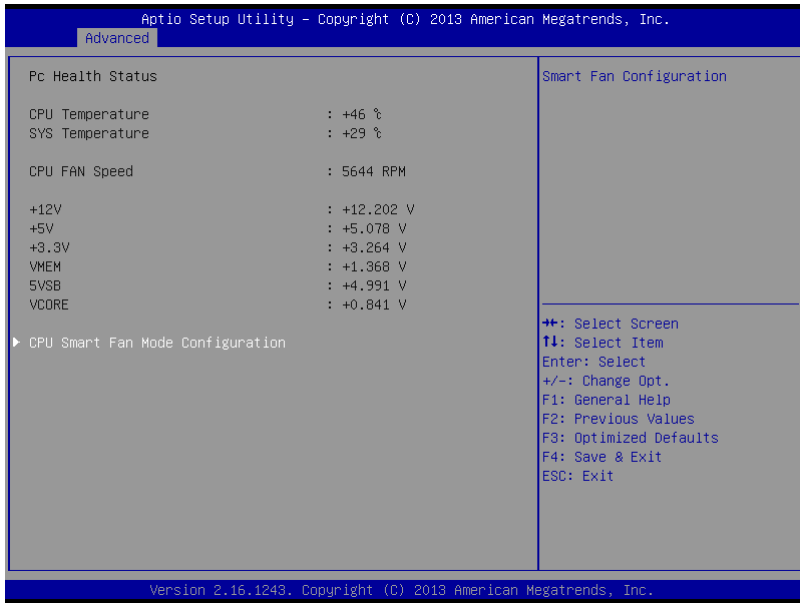

Options summary:

CPU Smart Fan Mode Configuration

### 3.4.4.1 CPU Smart Fan control: Full mode

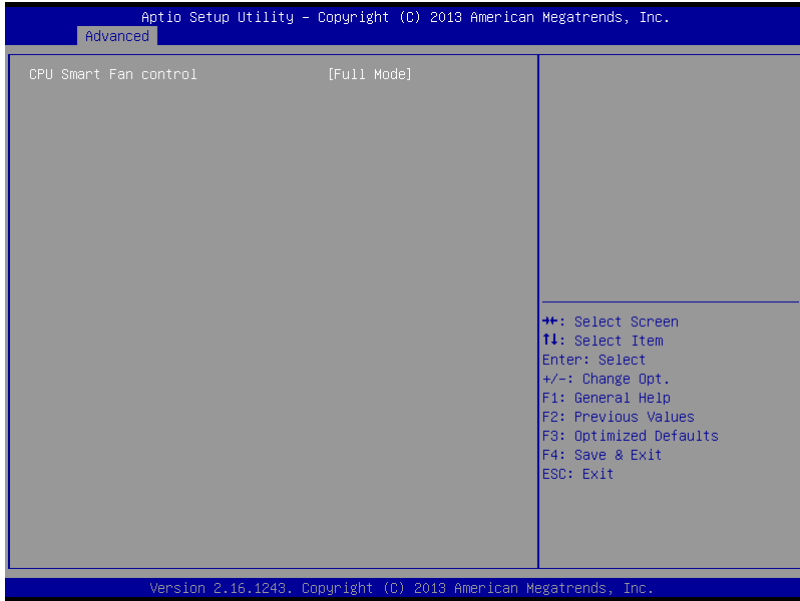

### 3.4.4.2 CPU Smart Fan control: Manual Mode by PWM



Options summary:

Manual Setting	70	Optimal Default, Failsafe Default
Set Fan at fixed Duty-Cycle Min=0 Max=100 Please input Dec number.		

### 3.4.4.3 CPU Smart Fan control: Auto Mode by PWM

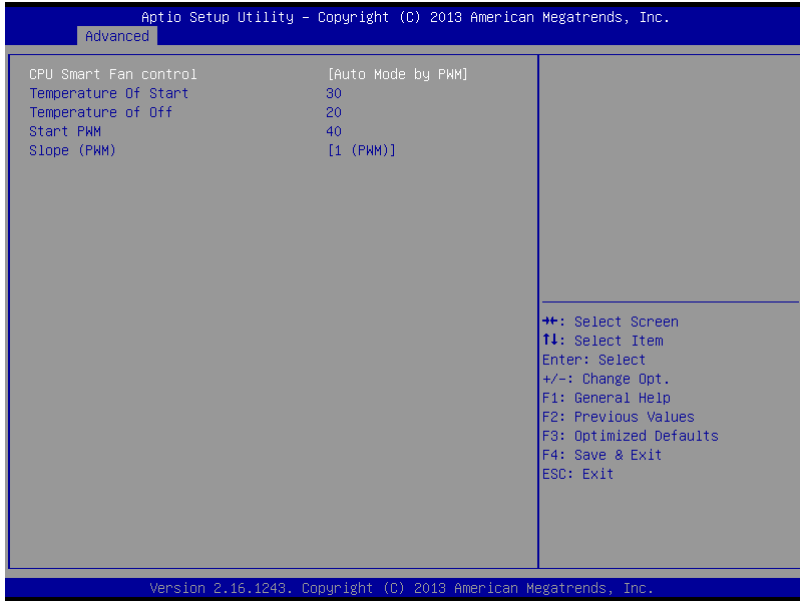

Options summary:

Temperature of Start	30	Optimal Default, Failsafe Default
Temperature of Start		
Temperature of Off	20	Optimal Default, Failsafe Default
Temperature of Off		
Start PWM	40	Optimal Default, Failsafe Default
Start PWM		
Slope (PWM)	0 (PWM)	
	1 (PWM)	Optimal Default, Failsafe Default
	2 (PWM)	
	4 (PWM)	

	8 (PWM)	
	16 (PWM)	
	32 (PWM)	
	64 (PWM)	
Slope (PWM)		

### 3.4.5 Advanced: Dynamic Digital IO Configuration

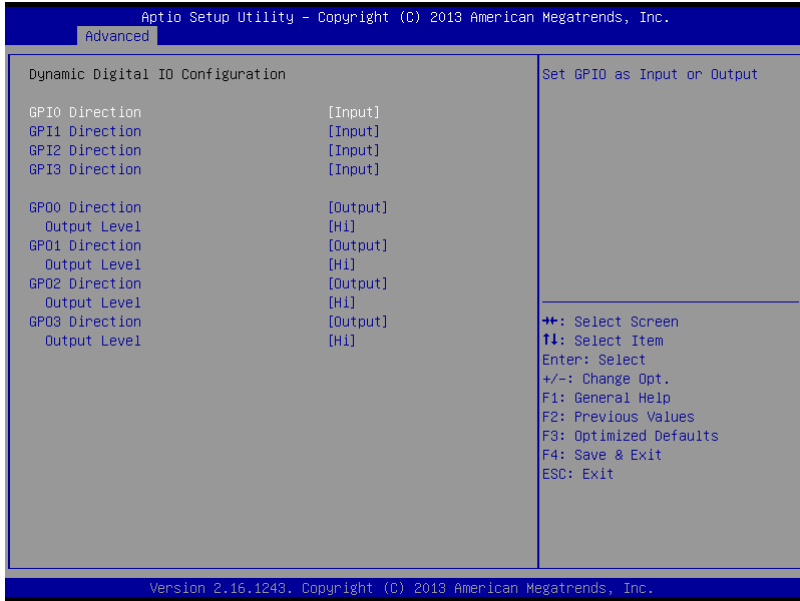

Options summary:

GPI* Direction	Output	Optimal Default, Failsafe Default
	Input	
Set GPIO as Input or Output		
GPO* Direction	Output	Optimal Default, Failsafe Default
	Input	
Set GPIO as Input or Output		
Output Level	Hi	Optimal Default, Failsafe Default
	Low	
Set GPIO Output as Hi or Low.		

### 3.4.6 Advanced: Power Management

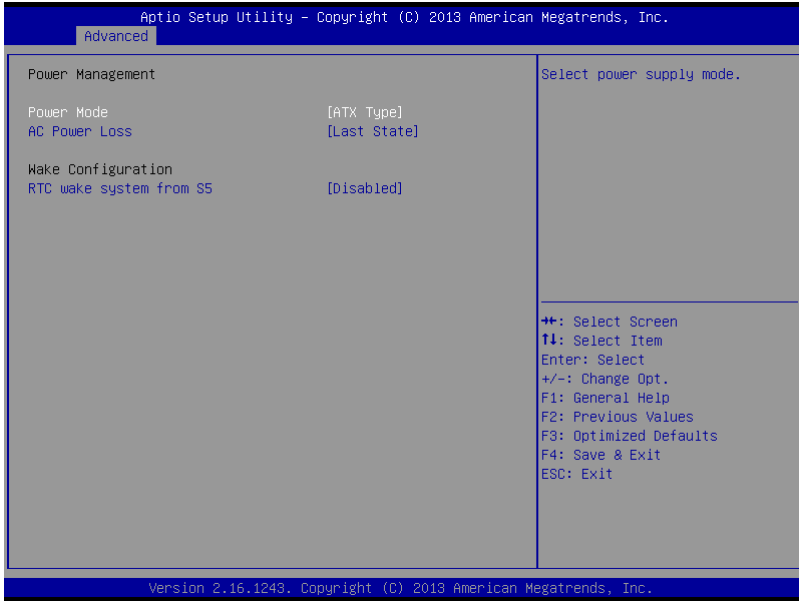

Options summary:

Power Mode	ATX Type	Optimal Default, Failsafe Default
	AT Type	
Select power supply mode.		
Restore on Power Loss	Last State	Optimal Default, Failsafe Default
	Always On	
	Always Off	
Power failure feature / AC Power Loss feature.		
RTC wake system from S5	Disabled	Optimal Default, Failsafe Default
	Fixed Time	
	Dynamic Time	



Fixed Time : System will wake on the hr::min::sec specified.

Dynamic Time : System will wake on the current time + Increase minute(s).

### 3.4.7 Advanced: Trusted Computing

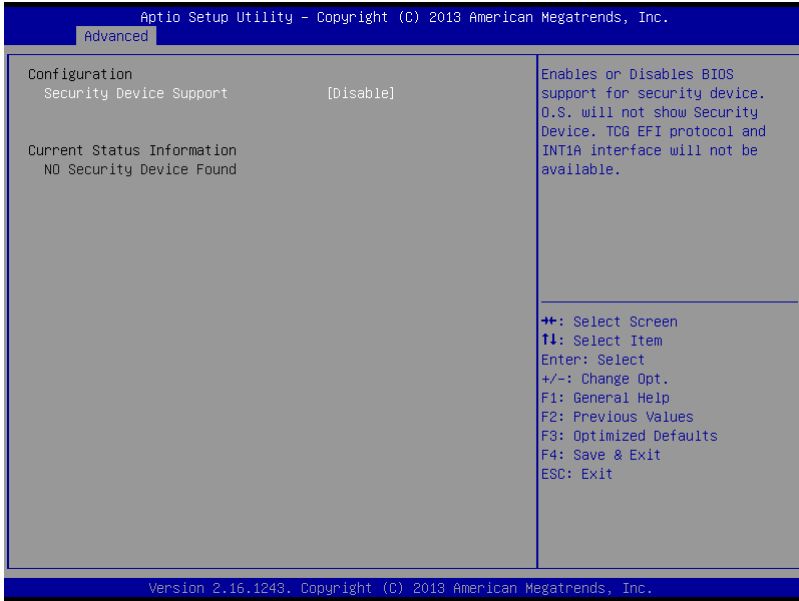

Options summary:

Security Device Support	Disable	Optimal Default, Failsafe Default
	Enable	
<p>Enables or Disables BIOS support for security device.</p> <p>O.S. will not show Security Device. TCG EFI protocol and INT1A interface will not be available.</p>		

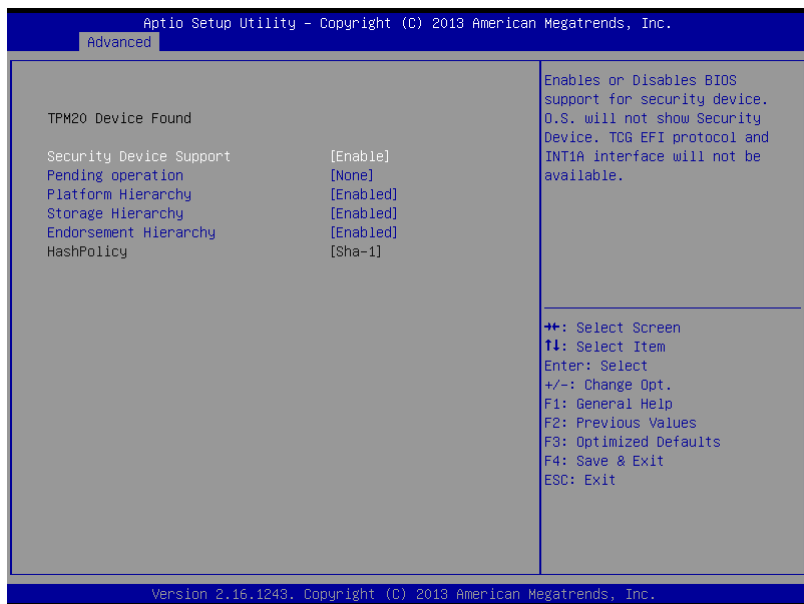

Options summary:

Security Device Support	Disable	Optimal Default, Failsafe Default
	Enable	
Enables or Disables BIOS support for security device. O.S. will not show Security Device. TCG EFI protocol and INT1A interface will not be available.		
Pending operation	None	Optimal Default, Failsafe Default
	TPM Clear	
Schedule an Operation for the Security Device. Note : Your Computer will reboot during restart in order to change State of Security Device.		
Platform Hierarchy	Disable	Optimal Default, Failsafe Default
	Enable	
Platform Hierarchy HELP.		
Storage Hierarchy	Disable	

	Enable	Optimal Default, Failsafe Default
Storage Hierarchy HELP		

Endorsement	Disable	
Hierarchy	Enable	Optimal Default, Failsafe Default
Endorsement Hierarchy HELP		

### 3.4.8 Advanced: SIO Configuration



### 3.4.8.1 Serial Port 9 Configuration



Options summary:

Use This Device	Disabled	Optimal Default, Failsafe Default
	Enabled	
Enable or Disable this logical device.		
Possible:	Use Automatic Settings	Optimal Default, Failsafe Default
	IO=2D8h; IRQ=11; DMA;	
	IO=2C8h; IRQ=11; DMA;	
Allows user to change Device's Resource settings. New settings will be reflected on This Setup Page after System restarts.		

### 3.4.8.2 Serial Port 10 Configuration



Options summary:

Use This Device	Disabled	Optimal Default, Failsafe Default
	Enabled	
Enable or Disable this logical device.		
Possible:	Use Automatic Settings	Optimal Default, Failsafe Default
	IO=2C8h; IRQ=10; DMA;	
	IO=2D8h; IRQ=10; DMA;	
Allows user to change Device's Resource settings. New settings will be reflected on This Setup Page after System restarts.		

### 3.5 Setup submenu: Chipset

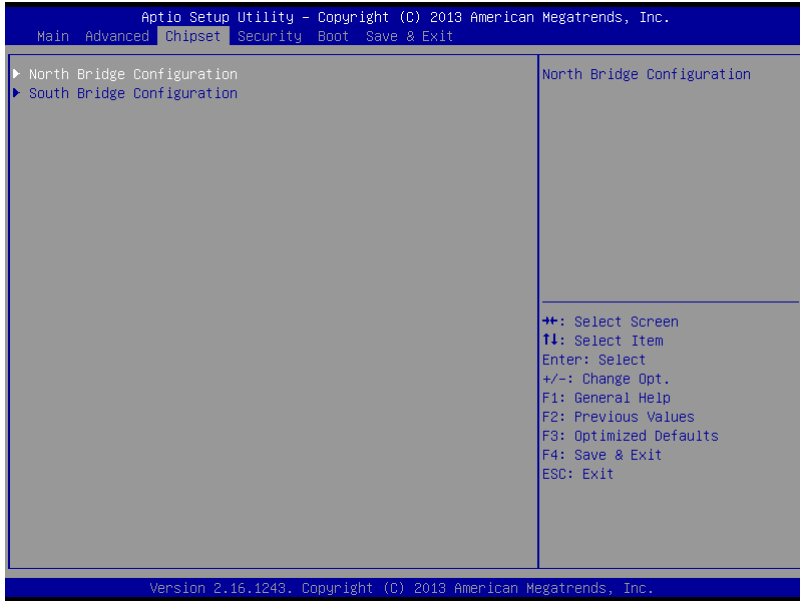



### 3.5.1 Chipset: North Bridge

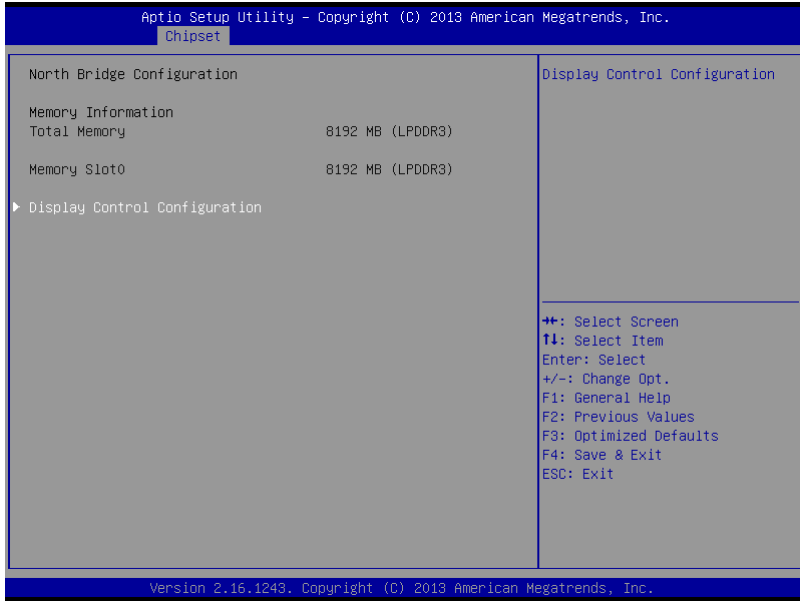

### 3.5.11 North Bridge: Display Control Configuration

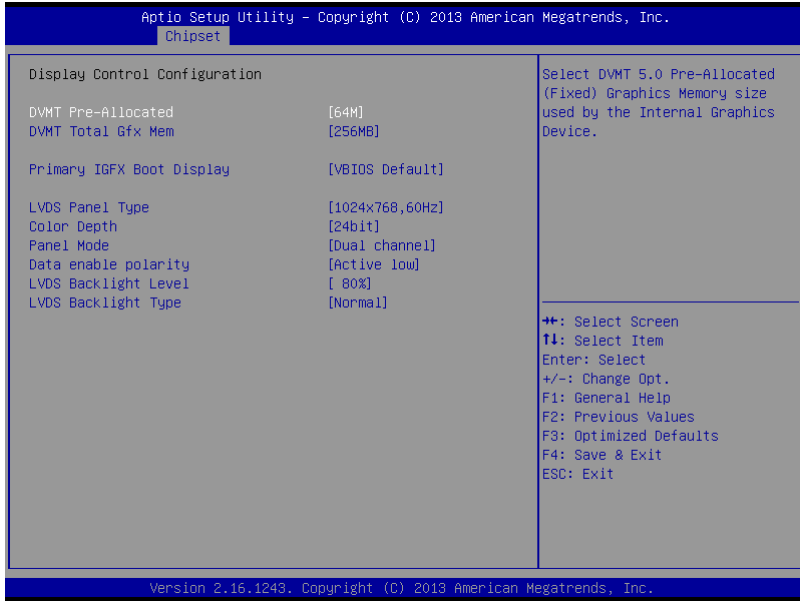

Options summary:

DVMT Pre-Allocated	64M	Optimal Default, Failsafe Default
	96M	
	128M	
	160M ...	
	512M	
Select DVMT 5.0 Pre-Allocated (Fixed) Graphics Memory size used by the Internal Graphics Device.		
DVMT Total Gfx Mem	128MB	Optimal Default, Failsafe Default
	256MB	
	Max	
Select DVMT 5.0 Total Graphics Memory size used by the Internal Graphics Device.		

Primary IGFX Boot Display	VBIOS Default	Optimal Default, Failsafe Default
	CRT	
	LVDS	
	DP/HDMI	
Select the Video Device which will be activated during POST. This has no effect if external graphics present. Secondary boot display selection will appear based on your selection. VGA modes will be supported only on primary display		
LVDS Panel Type	640x480, 60Hz	Optimal Default, Failsafe Default
	800x480, 60Hz	
	800x600, 60Hz	
	1024x600, 60Hz	
	1024x768, 60Hz	
	1280x768, 60Hz	
	1280x1024, 60Hz	
	1366x768, 60Hz	
	1440x900, 60Hz	
	1600x1200, 60Hz	
	1920x1080, 60Hz	
	1920x1200, 60Hz	
	1280x800, 60Hz	
	1024x600, 60Hz	
Select LCD panel used by Internal Graphics Device by selecting the appropriate setup item.		
Color Depth	24bit	Optimal Default, Failsafe Default
	18bit	
24bit or 18bit.		

Panel Mode	Single Channel	Optimal Default, Failsafe Default
	Dual Channel	
Single Channel / Dual Channel.		
Data enable polarity	Active Low	Optimal Default, Failsafe Default
	Active High	
Active High / Low .		

LVDS Backlight Level	100%	Optimal Default, Failsafe Default
	90%	
	80%	
	70%	
	60%	
	50%	
	40%	
	30%	
	20%	
	10%	
0%		
Select Backlight brightness of LVDS.		
LVDS Backlight Type	Normal	Optimal Default, Failsafe Default
	Inverted	
Select Backlight Control Type.		

### 3.5.2 Chipset: South Bridge

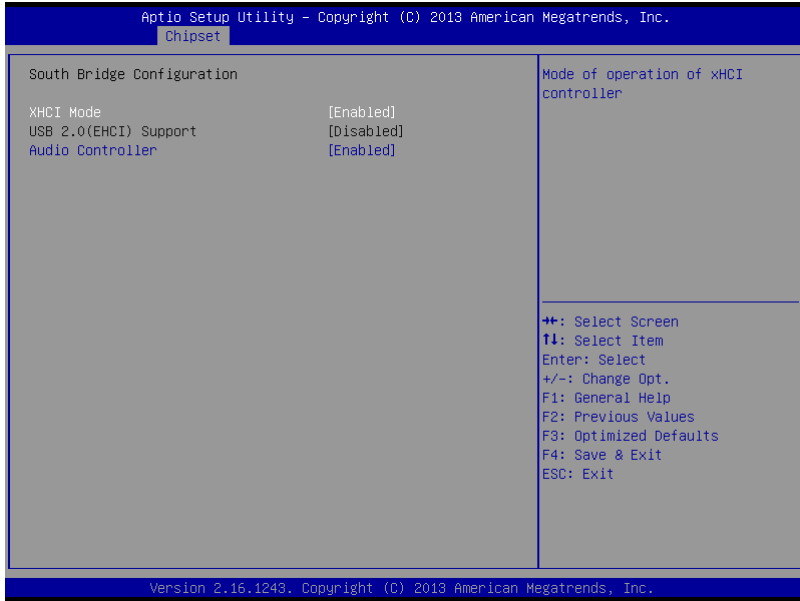

Options summary:

XHCI Mode	Enabled	Optimal Default, Failsafe Default
	Disabled	
Mode of operation of xHCI controller.		
Audio Controller	Enabled	Optimal Default, Failsafe Default
	Disabled	
Control Detection of the Azalia device.		
Disabled = Azalia will be unconditionally disabled.		
Enabled = Azalia will be unconditionally Enabled.		
Auto = Azalia will be enabled if present disabled otherwise.		

## 3.6 Setup submenu: Security

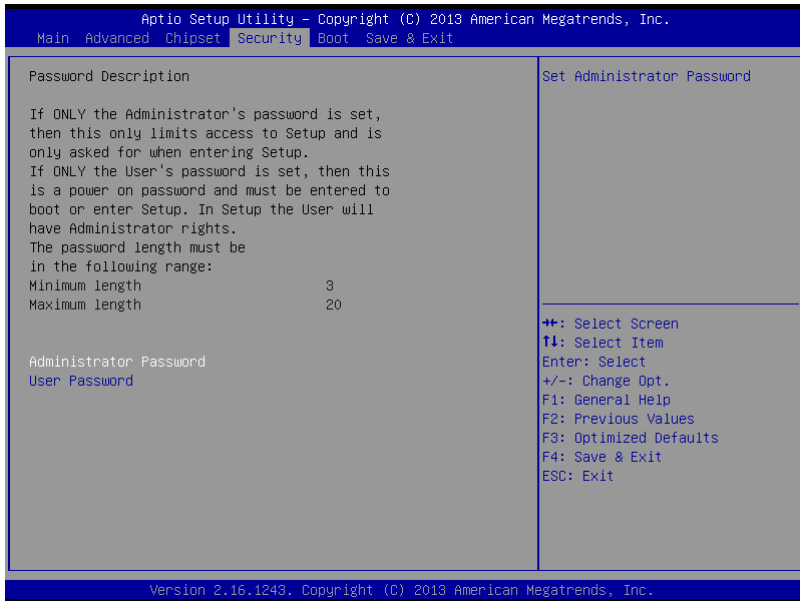

### Change User/ Supervisor Password

You can install a Supervisor password, and if you install a supervisor password, you can then install a user password. A user password does not provide access to many of the features in the Setup utility.

If you highlight these items and press Enter, a dialog box appears which lets you enter a password. You can enter no more than six letters or numbers. Press Enter after you have typed in the password. A second dialog box asks you to retype the password for confirmation. Press Enter after you have retyped it correctly. The password is required at boot time, or when the user enters the Setup utility.

### Removing the Password

Highlight this item and type in the current password. At the next dialog box press Enter to disable password protection.

### 3.7 Setup submenu: Boot

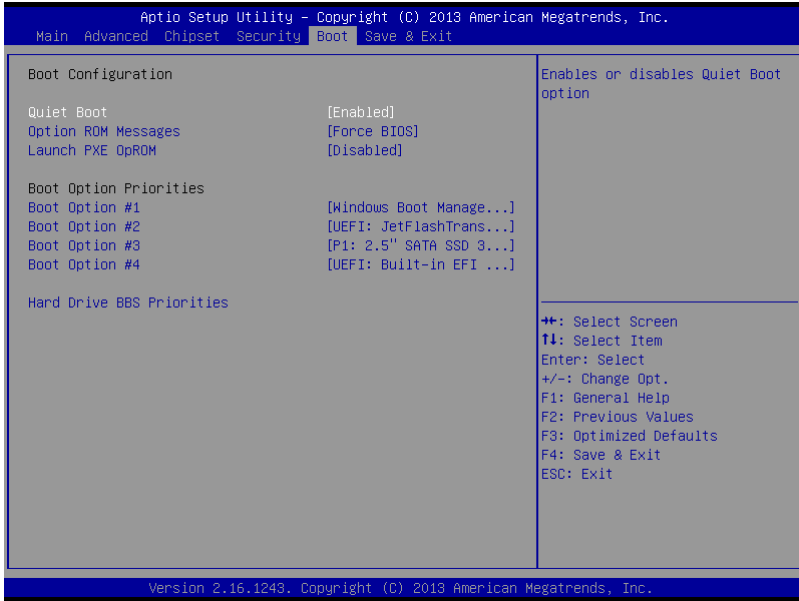

Options summary:

Quiet Boot	Disabled	Default
	Enabled	
Enables or Disables Quiet Boot option.		
Option ROM Messages	Force BIOS	Default
	Keep Current	
Set display mode for Option ROM		
Launch PXE OpROM	Disabled	Default
	Enabled	
Controls the execution of LAN PXE OpROM.		

### 3.7.1 BBS Priorities

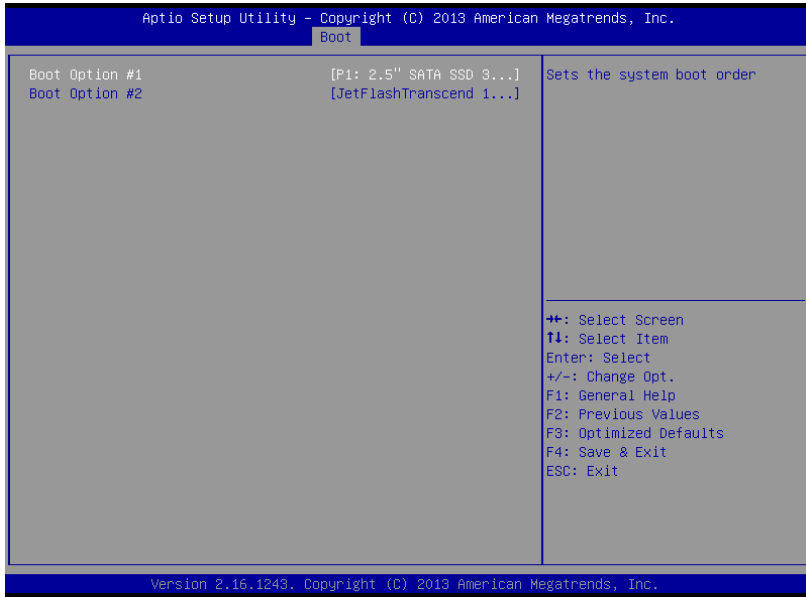



### 3.8 Setup submenu: Save & Exit

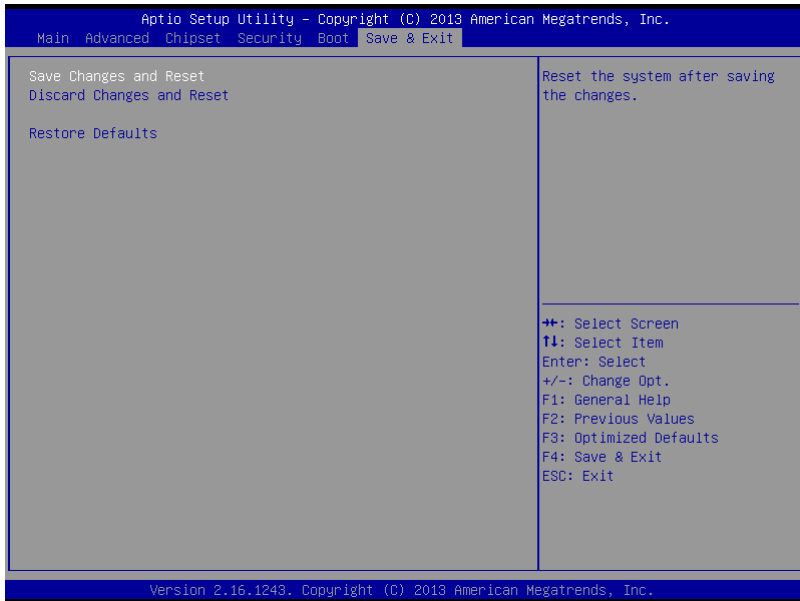

# Chapter 4

---

Drivers Installation

## 4.1 Driver Download/Installation

---

Drivers for the COM-BT-A30 can be downloaded from the product page on the AAEON website by following this link:

<https://www.aaeon.com/en/p/modulescom-express-modules-com-bt>

Download the driver(s) you need and follow the steps below to install them.

### Step 1 – Install Chipset Driver

1. Open the **Step1 - Chipset** folder followed by **SetupChipset.exe**
2. Follow the instructions
3. Drivers will be installed automatically

### Step 2 – Install Graphics Driver

1. Open the **Step2 - Graphics** folder and select your OS
2. Open the **Setup.exe** file in the folder
3. Follow the instructions
4. Drivers will be installed automatically

### Step 3 – Install LAN Driver

1. Open the **Step3 - Network** folder and select your OS
2. Open the **19.1\_20140410.exe** file in the folder
3. Follow the instructions
4. Drivers will be installed automatically

#### Step 4 – Install xHCI Driver

1. Open the **STEP4 - xHCI** folder
2. Open the **Setup.exe** file in the folder
3. Follow the instructions
4. Drivers will be installed automatically

#### Step 5 – Install Intel Sideband Fabric Device Driver

1. Open the **Step5 – Intel Sideband Fabric Device** folder
2. Open the **Setup.exe** file in the folder
3. Follow the instructions
4. Drivers will be installed automatically

#### Step 6 – Install TPM Driver

1. Open the **STEP6 - TPM** folder
2. Open the **Setup.exe** file in the folder
3. Follow the instructions
4. Drivers will be installed automatically

# Appendix A

---

## Watchdog Timer Programming

## A.1 Watchdog Timer Initial Program

	Default Value	Note
Index	0x284(Note1)	BRAM Index Register
Data	0x285(Note2)	BRAM Data Register
Logical Device Number	0xA8(Note3)	Watch dog Logical Device Number
Function and Device Number	0x00(Note4)	Watch dog Function/Device Number

	Option Register	BitNum	Value	Note
Timer Counter	0x00(Note5)		(Note10)	Time of watchdog timer (0~255)
Counting Unit	0x01(Note6)	0(Note7)	0(Note11)	Select time unit. 0: second 1: minute
Watchdog RST pulse width	0x01(Note8)	[3:2](Note9)	0(Note12)	0: 20ms 1: 60ms 2: 100ms 3: 250ms

```

*****
// Embedded BRAM relative definition (Please reference to Table 1)
#define byte EcBRAMIndex //This parameter is represented from Note1
#define byte EcBRAMData //This parameter is represented from Note2
#define byte BRAMLDNReg //This parameter is represented from Note3
#define byte BRAMFnDataReg //This parameter is represented from Note4
#define void EcBRAMWriteByte(byte Offset, byte Value);
#define byte EcBRAMReadByte(byte Offset);
#define void IOWriteByte(byte Offset, byte Value);
#define byte IOReadByte(byte Offset);
// Watch Dog relative definition (Please reference to Table 2)
#define byte TimerReg //This parameter is represented from Note5
#define byte TimerVal // This parameter is represented from Note10
#define byte UnitReg //This parameter is represented from Note6
#define byte UnitBit //This parameter is represented from Note7
#define byte UnitVal //This parameter is represented from Note11
#define byte RSTReg //This parameter is represented from Note8
#define byte RSTBit //This parameter is represented from Note9
#define byte RSTVal //This parameter is represented from Note12
*****

```

```
*****
VOID Main(){
    // Procedure : AaeonWDTConfig
    // (byte)Timer : Time of WDT timer.(0x00~0xFF)
    // (boolean)Unit : Select time unit(0: second, 1: minute).
    AaeonWDTConfig();

    // Procedure : AaeonWDTEnable
    // This procedure will enable the WDT counting.
    AaeonWDTEnable();
}
*****
```



```

*****
// Procedure : AaeonWDTEnable
VOID  AaeonWDTEnable (){
WDTEnableDisable(1);
}

// Procedure : AaeonWDTConfig
VOID  AaeonWDTConfig (){
// Disable WDT counting
WDTEnableDisable(0);
// WDT relative parameter setting
WDTParameterSetting();
}

VOID  WDTEnableDisable(byte Value){
    ECBRAMWriteByte(TimerReg , Value);
}

VOID  WDTParameterSetting(){
    Byte TempByte;

// Watchdog Timer counter setting
ECBRAMWriteByte(TimerReg , TimerVal);
    // WDT counting unit setting
TempByte = ECBRAMReadByte(UnitReg);
TempByte |= (UnitVal << UnitBit);
ECBRAMWriteByte(UnitReg , TempByte);
// WDT RST pulse width setting
TempByte = ECBRAMReadByte(RSTReg);
TempByte |= (RSTVal << RSTBit);
ECBRAMWriteByte(RSTReg , TempByte);
}
*****

```

```

*****
VOID  ECBRAMWriteByte(byte OPReg, byte OPBit, byte Value){
    IOWriteByte(EcBRAMIndex, 0x10);
    IOWriteByte(EcBRAMData, BRAMLDNReg);
    IOWriteByte(EcBRAMIndex, 0x11);
    IOWriteByte(EcBRAMData, BRAMFnDataReg);

    IOWriteByte(EcBRAMIndex, 0x13 + OPReg);
    IOWriteByte(EcBRAMData, Value);

    IOWriteByte(EcBRAMIndex, 0x12);
    IOWriteByte(EcBRAMData, 0x30);          //Write start
}

Byte  ECBRAMReadByte(byte OPReg){
    IOWriteByte(EcBRAMIndex, 0x10);
    IOWriteByte(EcBRAMData, BRAMLDNReg);
    IOWriteByte(EcBRAMIndex, 0x11);
    IOWriteByte(EcBRAMData, BRAMFnDataReg);

    IOWriteByte(EcBRAMIndex, 0x12);
    IOWriteByte(EcBRAMData, 0x10);        //Read start

    IOWriteByte(EcBRAMIndex, 0x13 + OPReg);
    Return  IOReadByte(EcBRAMData, Value);
}
*****

```

# Appendix B

---

I/O Information

## B.1 I/O Address Map















































Input/output (I/O)	
[0000000000000000 - 000000000000006F]	PCI Express Root Complex
[0000000000000020 - 0000000000000021]	Programmable interrupt controller
[0000000000000024 - 0000000000000025]	Programmable interrupt controller
[0000000000000028 - 0000000000000029]	Programmable interrupt controller
[000000000000002C - 000000000000002D]	Programmable interrupt controller
[000000000000002E - 000000000000002F]	Motherboard resources
[0000000000000030 - 0000000000000031]	Programmable interrupt controller
[0000000000000034 - 0000000000000035]	Programmable interrupt controller
[0000000000000038 - 0000000000000039]	Programmable interrupt controller
[000000000000003C - 000000000000003D]	Programmable interrupt controller
[0000000000000040 - 0000000000000043]	System timer
[000000000000004E - 000000000000004F]	Motherboard resources
[0000000000000050 - 0000000000000053]	System timer
[0000000000000061 - 0000000000000061]	Motherboard resources
[0000000000000063 - 0000000000000063]	Motherboard resources
[0000000000000065 - 0000000000000065]	Motherboard resources
[0000000000000067 - 0000000000000067]	Motherboard resources
[0000000000000070 - 0000000000000070]	Motherboard resources
[0000000000000070 - 0000000000000077]	System CMOS/real time clock
[0000000000000078 - 0000000000000CF7]	PCI Express Root Complex
[0000000000000080 - 000000000000008F]	Motherboard resources
[0000000000000092 - 0000000000000092]	Motherboard resources
[00000000000000A0 - 00000000000000A1]	Programmable interrupt controller
[00000000000000A4 - 00000000000000A5]	Programmable interrupt controller
[00000000000000A8 - 00000000000000A9]	Programmable interrupt controller
[00000000000000AC - 00000000000000AD]	Programmable interrupt controller
[00000000000000B0 - 00000000000000B1]	Programmable interrupt controller
[00000000000000B2 - 00000000000000B3]	Motherboard resources
[00000000000000B4 - 00000000000000B5]	Programmable interrupt controller
[00000000000000B8 - 00000000000000B9]	Programmable interrupt controller
[00000000000000BC - 00000000000000BD]	Programmable interrupt controller
[00000000000000C8 - 00000000000000CF]	Communications Port (COM10)
[00000000000000D8 - 00000000000000DF]	Communications Port (COM9)
[00000000000003B0 - 00000000000003BB]	Intel(R) HD Graphics
[00000000000003C0 - 00000000000003DF]	Intel(R) HD Graphics
[0000000000000400 - 000000000000047F]	Motherboard resources
[00000000000004D0 - 00000000000004D1]	Programmable interrupt controller
[0000000000000500 - 00000000000005FE]	Motherboard resources
[0000000000000600 - 000000000000061F]	Motherboard resources
[0000000000000680 - 000000000000069F]	Motherboard resources
[0000000000000D00 - 0000000000000FFF]	PCI Express Root Complex
[0000000000000D00 - 0000000000000DFF]	Intel(R) Atom(TM)/Celeron(R)/Pentium(R) Processor PCI Express - Root Port 4 - 0F4E
[0000000000000E00 - 0000000000000E1F]	Intel(R) Atom(TM)/Celeron(R)/Pentium(R) Processor Platform Control Unit - SMBus Port - 0F12
[0000000000000E20 - 0000000000000E3F]	Intel(R) Atom(TM)/Celeron(R)/Pentium(R) Processor AHCI - 0F23
[0000000000000E40 - 0000000000000E43]	Intel(R) Atom(TM)/Celeron(R)/Pentium(R) Processor AHCI - 0F23
[0000000000000E50 - 0000000000000E57]	Intel(R) Atom(TM)/Celeron(R)/Pentium(R) Processor AHCI - 0F23
[0000000000000E60 - 0000000000000E63]	Intel(R) Atom(TM)/Celeron(R)/Pentium(R) Processor AHCI - 0F23
[0000000000000E70 - 0000000000000E77]	Intel(R) Atom(TM)/Celeron(R)/Pentium(R) Processor AHCI - 0F23
[0000000000000E80 - 0000000000000E87]	Intel(R) HD Graphics





























































## B.2 Memory Address Map



























































Address Range	Device
[0000000000A0000 - 0000000000BFFFF]	Intel(R) HD Graphics
[0000000000A0000 - 0000000000BFFFF]	PCI Express Root Complex
[0000000000C0000 - 0000000000DFFFF]	PCI Express Root Complex
[0000000000E0000 - 0000000000FFFFFF]	PCI Express Root Complex
[00000000C0000000 - 00000000CFFFFFFF]	Intel(R) HD Graphics
[00000000C0000000 - 00000000D0716FFE]	PCI Express Root Complex
[00000000D0000000 - 00000000D03FFFFFFF]	Intel(R) HD Graphics
[00000000D0400000 - 00000000D04FFFFF]	Intel(R) Atom(TM)/Celeron(R)/Pentium(R) Processor Trusted Execution Engine Interface - 0F18
[00000000D0500000 - 00000000D05FFFFFFF]	Intel(R) Atom(TM)/Celeron(R)/Pentium(R) Processor Trusted Execution Engine Interface - 0F18
[00000000D0600000 - 00000000D061FFFF]	Intel(R) I211 Gigabit Network Connection
[00000000D0600000 - 00000000D066FFFFF]	Intel(R) Atom(TM)/Celeron(R)/Pentium(R) Processor PCI Express - Root Port 4 - 0F4E
[00000000D0620000 - 00000000D0623FFF]	Intel(R) I211 Gigabit Network Connection
[00000000D0700000 - 00000000D070FFFF]	Intel(R) USB 3.0 eXtensible Host Controller - 0100 (Microsoft)
[00000000D0710000 - 00000000D0713FFF]	High Definition Audio Controller
[00000000D0714000 - 00000000D071401F]	Intel(R) Atom(TM)/Celeron(R)/Pentium(R) Processor Platform Control Unit - SMBus Port - 0F12
[00000000D0716000 - 00000000D07167FF]	Intel(R) Atom(TM)/Celeron(R)/Pentium(R) Processor AHCI - 0F23
[00000000E0000000 - 00000000EFFFFFFF]	Motherboard resources
[00000000E00000D0 - 00000000E00000DB]	Intel(R) Sideband Fabric Device
[00000000FED00000 - 00000000FED003FF]	High precision event timer
[00000000FED01000 - 00000000FED01FFF]	Motherboard resources
[00000000FED03000 - 00000000FED03FFF]	Motherboard resources
[00000000FED04000 - 00000000FED04FFF]	Motherboard resources
[00000000FED08000 - 00000000FED08FFF]	Motherboard resources
[00000000FED1C000 - 00000000FED1CFFF]	Motherboard resources
[00000000FEE00000 - 00000000FEEFFFFF]	Motherboard resources
[00000000FEF00000 - 00000000FEF9FFFF]	Motherboard resources
[00000000FF000000 - 00000000FFFFFFFF]	Intel(R) 82802 Firmware Hub Device

## B.3 IRQ Mapping Chart



























































Interrupt request (IRQ)	Device
(ISA) 0x00000000 (00)	System timer
(ISA) 0x00000008 (08)	High precision event timer
(ISA) 0x0000000A (10)	Communications Port (COM10)
(ISA) 0x0000000B (11)	Communications Port (COM9)
(ISA) 0x00000051 (81)	Microsoft ACPI-Compliant System
(ISA) 0x00000052 (82)	Microsoft ACPI-Compliant System
(ISA) 0x00000053 (83)	Microsoft ACPI-Compliant System
(ISA) 0x00000054 (84)	Microsoft ACPI-Compliant System
(ISA) 0x00000055 (85)	Microsoft ACPI-Compliant System
(ISA) 0x00000056 (86)	Microsoft ACPI-Compliant System
(ISA) 0x00000057 (87)	Microsoft ACPI-Compliant System
(ISA) 0x00000058 (88)	Microsoft ACPI-Compliant System
(ISA) 0x00000059 (89)	Microsoft ACPI-Compliant System
(ISA) 0x0000005A (90)	Microsoft ACPI-Compliant System
(ISA) 0x0000005B (91)	Microsoft ACPI-Compliant System
(ISA) 0x0000005C (92)	Microsoft ACPI-Compliant System
(ISA) 0x0000005D (93)	Microsoft ACPI-Compliant System
(ISA) 0x0000005E (94)	Microsoft ACPI-Compliant System
(ISA) 0x0000005F (95)	Microsoft ACPI-Compliant System
(ISA) 0x00000060 (96)	Microsoft ACPI-Compliant System
(ISA) 0x00000061 (97)	Microsoft ACPI-Compliant System
(ISA) 0x00000062 (98)	Microsoft ACPI-Compliant System
(ISA) 0x00000063 (99)	Microsoft ACPI-Compliant System
(ISA) 0x00000064 (100)	Microsoft ACPI-Compliant System





























































 (ISA) 0x0000065 (101)	Microsoft ACPI-Compliant System
 (ISA) 0x0000066 (102)	Microsoft ACPI-Compliant System
 (ISA) 0x0000067 (103)	Microsoft ACPI-Compliant System
 (ISA) 0x0000068 (104)	Microsoft ACPI-Compliant System
 (ISA) 0x0000069 (105)	Microsoft ACPI-Compliant System
 (ISA) 0x000006A (106)	Microsoft ACPI-Compliant System
 (ISA) 0x000006B (107)	Microsoft ACPI-Compliant System
 (ISA) 0x000006C (108)	Microsoft ACPI-Compliant System
 (ISA) 0x000006D (109)	Microsoft ACPI-Compliant System
 (ISA) 0x000006E (110)	Microsoft ACPI-Compliant System
 (ISA) 0x000006F (111)	Microsoft ACPI-Compliant System
 (ISA) 0x0000070 (112)	Microsoft ACPI-Compliant System
 (ISA) 0x0000071 (113)	Microsoft ACPI-Compliant System
 (ISA) 0x0000072 (114)	Microsoft ACPI-Compliant System
 (ISA) 0x0000073 (115)	Microsoft ACPI-Compliant System
 (ISA) 0x0000074 (116)	Microsoft ACPI-Compliant System
 (ISA) 0x0000075 (117)	Microsoft ACPI-Compliant System
 (ISA) 0x0000076 (118)	Microsoft ACPI-Compliant System
 (ISA) 0x0000077 (119)	Microsoft ACPI-Compliant System
 (ISA) 0x0000078 (120)	Microsoft ACPI-Compliant System
 (ISA) 0x0000079 (121)	Microsoft ACPI-Compliant System
 (ISA) 0x000007A (122)	Microsoft ACPI-Compliant System
 (ISA) 0x000007B (123)	Microsoft ACPI-Compliant System
 (ISA) 0x000007C (124)	Microsoft ACPI-Compliant System
 (ISA) 0x000007D (125)	Microsoft ACPI-Compliant System
 (ISA) 0x000007E (126)	Microsoft ACPI-Compliant System
 (ISA) 0x000007F (127)	Microsoft ACPI-Compliant System
 (ISA) 0x0000080 (128)	Microsoft ACPI-Compliant System
 (ISA) 0x0000081 (129)	Microsoft ACPI-Compliant System
 (ISA) 0x0000082 (130)	Microsoft ACPI-Compliant System
 (ISA) 0x0000083 (131)	Microsoft ACPI-Compliant System
 (ISA) 0x0000084 (132)	Microsoft ACPI-Compliant System
 (ISA) 0x0000085 (133)	Microsoft ACPI-Compliant System
 (ISA) 0x0000086 (134)	Microsoft ACPI-Compliant System
 (ISA) 0x0000087 (135)	Microsoft ACPI-Compliant System
 (ISA) 0x0000088 (136)	Microsoft ACPI-Compliant System
 (ISA) 0x0000089 (137)	Microsoft ACPI-Compliant System
 (ISA) 0x000008A (138)	Microsoft ACPI-Compliant System
 (ISA) 0x000008B (139)	Microsoft ACPI-Compliant System
 (ISA) 0x000008C (140)	Microsoft ACPI-Compliant System
 (ISA) 0x000008D (141)	Microsoft ACPI-Compliant System
 (ISA) 0x000008E (142)	Microsoft ACPI-Compliant System
 (ISA) 0x000008F (143)	Microsoft ACPI-Compliant System
 (ISA) 0x0000090 (144)	Microsoft ACPI-Compliant System
 (ISA) 0x0000091 (145)	Microsoft ACPI-Compliant System
 (ISA) 0x0000092 (146)	Microsoft ACPI-Compliant System
 (ISA) 0x0000093 (147)	Microsoft ACPI-Compliant System
(ISA) 0x0000094 (148)	Microsoft ACPI-Compliant System
(ISA) 0x0000095 (149)	Microsoft ACPI-Compliant System
(ISA) 0x0000096 (150)	Microsoft ACPI-Compliant System
(ISA) 0x0000097 (151)	Microsoft ACPI-Compliant System
(ISA) 0x0000098 (152)	Microsoft ACPI-Compliant System
(ISA) 0x0000099 (153)	Microsoft ACPI-Compliant System
(ISA) 0x000009A (154)	Microsoft ACPI-Compliant System
(ISA) 0x000009B (155)	Microsoft ACPI-Compliant System
(ISA) 0x000009C (156)	Microsoft ACPI-Compliant System
(ISA) 0x000009D (157)	Microsoft ACPI-Compliant System
(ISA) 0x000009E (158)	Microsoft ACPI-Compliant System
(ISA) 0x000009F (159)	Microsoft ACPI-Compliant System
(ISA) 0x00000A0 (160)	Microsoft ACPI-Compliant System
(ISA) 0x00000A1 (161)	Microsoft ACPI-Compliant System
(ISA) 0x00000A2 (162)	Microsoft ACPI-Compliant System































































 (ISA) 0x000000A3 (163)	Microsoft ACPI-Compliant System
 (ISA) 0x000000A4 (164)	Microsoft ACPI-Compliant System
 (ISA) 0x000000A5 (165)	Microsoft ACPI-Compliant System
 (ISA) 0x000000A6 (166)	Microsoft ACPI-Compliant System
 (ISA) 0x000000A7 (167)	Microsoft ACPI-Compliant System
 (ISA) 0x000000A8 (168)	Microsoft ACPI-Compliant System
 (ISA) 0x000000A9 (169)	Microsoft ACPI-Compliant System
 (ISA) 0x000000AA (170)	Microsoft ACPI-Compliant System
 (ISA) 0x000000AB (171)	Microsoft ACPI-Compliant System
 (ISA) 0x000000AC (172)	Microsoft ACPI-Compliant System
 (ISA) 0x000000AD (173)	Microsoft ACPI-Compliant System
 (ISA) 0x000000AE (174)	Microsoft ACPI-Compliant System
 (ISA) 0x000000AF (175)	Microsoft ACPI-Compliant System
 (ISA) 0x000000B0 (176)	Microsoft ACPI-Compliant System
 (ISA) 0x000000B1 (177)	Microsoft ACPI-Compliant System
 (ISA) 0x000000B2 (178)	Microsoft ACPI-Compliant System
 (ISA) 0x000000B3 (179)	Microsoft ACPI-Compliant System
 (ISA) 0x000000B4 (180)	Microsoft ACPI-Compliant System
 (ISA) 0x000000B5 (181)	Microsoft ACPI-Compliant System
 (ISA) 0x000000B6 (182)	Microsoft ACPI-Compliant System
 (ISA) 0x000000B7 (183)	Microsoft ACPI-Compliant System
 (ISA) 0x000000B8 (184)	Microsoft ACPI-Compliant System
 (ISA) 0x000000B9 (185)	Microsoft ACPI-Compliant System
 (ISA) 0x000000BA (186)	Microsoft ACPI-Compliant System
 (ISA) 0x000000BB (187)	Microsoft ACPI-Compliant System
 (ISA) 0x000000BC (188)	Microsoft ACPI-Compliant System
 (ISA) 0x000000BD (189)	Microsoft ACPI-Compliant System
 (ISA) 0x000000BE (190)	Microsoft ACPI-Compliant System
 (ISA) 0x000000BF (191)	Microsoft ACPI-Compliant System
 (ISA) 0x00000100 (256)	Microsoft ACPI-Compliant System
 (ISA) 0x00000101 (257)	Microsoft ACPI-Compliant System
 (ISA) 0x00000102 (258)	Microsoft ACPI-Compliant System
 (ISA) 0x00000103 (259)	Microsoft ACPI-Compliant System
 (ISA) 0x00000104 (260)	Microsoft ACPI-Compliant System
 (ISA) 0x00000105 (261)	Microsoft ACPI-Compliant System
 (ISA) 0x00000106 (262)	Microsoft ACPI-Compliant System
 (ISA) 0x00000107 (263)	Microsoft ACPI-Compliant System
 (ISA) 0x00000108 (264)	Microsoft ACPI-Compliant System
 (ISA) 0x00000109 (265)	Microsoft ACPI-Compliant System
 (ISA) 0x0000010A (266)	Microsoft ACPI-Compliant System
 (ISA) 0x0000010B (267)	Microsoft ACPI-Compliant System
 (ISA) 0x0000010C (268)	Microsoft ACPI-Compliant System
 (ISA) 0x0000010D (269)	Microsoft ACPI-Compliant System
 (ISA) 0x0000010E (270)	Microsoft ACPI-Compliant System
 (ISA) 0x0000010F (271)	Microsoft ACPI-Compliant System
 (ISA) 0x00000110 (272)	Microsoft ACPI-Compliant System
 (ISA) 0x00000111 (273)	Microsoft ACPI-Compliant System
 (ISA) 0x00000112 (274)	Microsoft ACPI-Compliant System
 (ISA) 0x00000113 (275)	Microsoft ACPI-Compliant System
 (ISA) 0x00000114 (276)	Microsoft ACPI-Compliant System
 (ISA) 0x00000115 (277)	Microsoft ACPI-Compliant System
 (ISA) 0x00000116 (278)	Microsoft ACPI-Compliant System
 (ISA) 0x00000117 (279)	Microsoft ACPI-Compliant System
 (ISA) 0x00000118 (280)	Microsoft ACPI-Compliant System
 (ISA) 0x00000119 (281)	Microsoft ACPI-Compliant System
 (ISA) 0x0000011A (282)	Microsoft ACPI-Compliant System
 (ISA) 0x0000011B (283)	Microsoft ACPI-Compliant System
 (ISA) 0x0000011C (284)	Microsoft ACPI-Compliant System
 (ISA) 0x0000011D (285)	Microsoft ACPI-Compliant System
 (ISA) 0x0000011E (286)	Microsoft ACPI-Compliant System
 (ISA) 0x0000011F (287)	Microsoft ACPI-Compliant System

 (ISA) 0x00000120 (288)	Microsoft ACPI-Compliant System
 (ISA) 0x00000121 (289)	Microsoft ACPI-Compliant System
 (ISA) 0x00000122 (290)	Microsoft ACPI-Compliant System
 (ISA) 0x00000123 (291)	Microsoft ACPI-Compliant System
 (ISA) 0x00000124 (292)	Microsoft ACPI-Compliant System
 (ISA) 0x00000125 (293)	Microsoft ACPI-Compliant System
 (ISA) 0x00000126 (294)	Microsoft ACPI-Compliant System
 (ISA) 0x00000127 (295)	Microsoft ACPI-Compliant System
 (ISA) 0x00000128 (296)	Microsoft ACPI-Compliant System
 (ISA) 0x00000129 (297)	Microsoft ACPI-Compliant System
 (ISA) 0x0000012A (298)	Microsoft ACPI-Compliant System
 (ISA) 0x0000012B (299)	Microsoft ACPI-Compliant System
 (ISA) 0x0000012C (300)	Microsoft ACPI-Compliant System
 (ISA) 0x0000012D (301)	Microsoft ACPI-Compliant System
 (ISA) 0x0000012E (302)	Microsoft ACPI-Compliant System
 (ISA) 0x0000012F (303)	Microsoft ACPI-Compliant System
 (ISA) 0x00000130 (304)	Microsoft ACPI-Compliant System
 (ISA) 0x00000131 (305)	Microsoft ACPI-Compliant System
 (ISA) 0x00000132 (306)	Microsoft ACPI-Compliant System
 (ISA) 0x00000133 (307)	Microsoft ACPI-Compliant System
 (ISA) 0x00000134 (308)	Microsoft ACPI-Compliant System
 (ISA) 0x00000135 (309)	Microsoft ACPI-Compliant System
 (ISA) 0x00000136 (310)	Microsoft ACPI-Compliant System
 (ISA) 0x00000137 (311)	Microsoft ACPI-Compliant System
 (ISA) 0x00000138 (312)	Microsoft ACPI-Compliant System
 (ISA) 0x00000139 (313)	Microsoft ACPI-Compliant System
 (ISA) 0x0000013A (314)	Microsoft ACPI-Compliant System
 (ISA) 0x0000013B (315)	Microsoft ACPI-Compliant System
 (ISA) 0x0000013C (316)	Microsoft ACPI-Compliant System
 (ISA) 0x0000013D (317)	Microsoft ACPI-Compliant System
 (ISA) 0x0000013E (318)	Microsoft ACPI-Compliant System
 (ISA) 0x0000013F (319)	Microsoft ACPI-Compliant System
 (ISA) 0x00000140 (320)	Microsoft ACPI-Compliant System
 (ISA) 0x00000141 (321)	Microsoft ACPI-Compliant System
 (ISA) 0x00000142 (322)	Microsoft ACPI-Compliant System
 (ISA) 0x00000143 (323)	Microsoft ACPI-Compliant System
 (ISA) 0x00000144 (324)	Microsoft ACPI-Compliant System
 (ISA) 0x00000145 (325)	Microsoft ACPI-Compliant System
 (ISA) 0x00000146 (326)	Microsoft ACPI-Compliant System
 (ISA) 0x00000147 (327)	Microsoft ACPI-Compliant System
 (ISA) 0x00000148 (328)	Microsoft ACPI-Compliant System
 (ISA) 0x00000149 (329)	Microsoft ACPI-Compliant System
 (ISA) 0x0000014A (330)	Microsoft ACPI-Compliant System
 (ISA) 0x0000014B (331)	Microsoft ACPI-Compliant System
 (ISA) 0x0000014C (332)	Microsoft ACPI-Compliant System
 (ISA) 0x0000014D (333)	Microsoft ACPI-Compliant System
 (ISA) 0x0000014E (334)	Microsoft ACPI-Compliant System
 (ISA) 0x0000014F (335)	Microsoft ACPI-Compliant System
 (ISA) 0x00000150 (336)	Microsoft ACPI-Compliant System
 (ISA) 0x00000151 (337)	Microsoft ACPI-Compliant System
 (ISA) 0x00000152 (338)	Microsoft ACPI-Compliant System
 (ISA) 0x00000153 (339)	Microsoft ACPI-Compliant System
 (ISA) 0x00000154 (340)	Microsoft ACPI-Compliant System
 (ISA) 0x00000155 (341)	Microsoft ACPI-Compliant System
 (ISA) 0x00000156 (342)	Microsoft ACPI-Compliant System
 (ISA) 0x00000157 (343)	Microsoft ACPI-Compliant System
 (ISA) 0x00000158 (344)	Microsoft ACPI-Compliant System
 (ISA) 0x00000159 (345)	Microsoft ACPI-Compliant System



 (ISA) 0x0000015A (346)	Microsoft ACPI-Compliant System
 (ISA) 0x0000015B (347)	Microsoft ACPI-Compliant System
 (ISA) 0x0000015C (348)	Microsoft ACPI-Compliant System
 (ISA) 0x0000015D (349)	Microsoft ACPI-Compliant System
 (ISA) 0x0000015E (350)	Microsoft ACPI-Compliant System
 (ISA) 0x0000015F (351)	Microsoft ACPI-Compliant System
 (ISA) 0x00000160 (352)	Microsoft ACPI-Compliant System
 (ISA) 0x00000161 (353)	Microsoft ACPI-Compliant System
 (ISA) 0x00000162 (354)	Microsoft ACPI-Compliant System
 (ISA) 0x00000163 (355)	Microsoft ACPI-Compliant System
 (ISA) 0x00000164 (356)	Microsoft ACPI-Compliant System
 (ISA) 0x00000165 (357)	Microsoft ACPI-Compliant System
 (ISA) 0x00000166 (358)	Microsoft ACPI-Compliant System
 (ISA) 0x00000167 (359)	Microsoft ACPI-Compliant System
 (ISA) 0x00000168 (360)	Microsoft ACPI-Compliant System
 (ISA) 0x00000169 (361)	Microsoft ACPI-Compliant System
 (ISA) 0x0000016A (362)	Microsoft ACPI-Compliant System
 (ISA) 0x0000016B (363)	Microsoft ACPI-Compliant System
 (ISA) 0x0000016C (364)	Microsoft ACPI-Compliant System
 (ISA) 0x0000016D (365)	Microsoft ACPI-Compliant System
 (ISA) 0x0000016E (366)	Microsoft ACPI-Compliant System
 (ISA) 0x0000016F (367)	Microsoft ACPI-Compliant System
 (ISA) 0x00000170 (368)	Microsoft ACPI-Compliant System
 (ISA) 0x00000171 (369)	Microsoft ACPI-Compliant System
 (ISA) 0x00000172 (370)	Microsoft ACPI-Compliant System
 (ISA) 0x00000173 (371)	Microsoft ACPI-Compliant System
 (ISA) 0x00000174 (372)	Microsoft ACPI-Compliant System
 (ISA) 0x00000175 (373)	Microsoft ACPI-Compliant System
 (ISA) 0x00000176 (374)	Microsoft ACPI-Compliant System
 (ISA) 0x00000177 (375)	Microsoft ACPI-Compliant System
 (ISA) 0x00000178 (376)	Microsoft ACPI-Compliant System
 (ISA) 0x00000179 (377)	Microsoft ACPI-Compliant System
 (ISA) 0x0000017A (378)	Microsoft ACPI-Compliant System
 (ISA) 0x0000017B (379)	Microsoft ACPI-Compliant System
 (ISA) 0x0000017C (380)	Microsoft ACPI-Compliant System
 (ISA) 0x0000017D (381)	Microsoft ACPI-Compliant System
 (ISA) 0x0000017E (382)	Microsoft ACPI-Compliant System
 (ISA) 0x0000017F (383)	Microsoft ACPI-Compliant System
 (ISA) 0x00000180 (384)	Microsoft ACPI-Compliant System
 (ISA) 0x00000181 (385)	Microsoft ACPI-Compliant System
 (ISA) 0x00000182 (386)	Microsoft ACPI-Compliant System
 (ISA) 0x00000183 (387)	Microsoft ACPI-Compliant System
 (ISA) 0x00000184 (388)	Microsoft ACPI-Compliant System
 (ISA) 0x00000185 (389)	Microsoft ACPI-Compliant System
 (ISA) 0x00000186 (390)	Microsoft ACPI-Compliant System
 (ISA) 0x00000187 (391)	Microsoft ACPI-Compliant System
 (ISA) 0x00000188 (392)	Microsoft ACPI-Compliant System
 (ISA) 0x00000189 (393)	Microsoft ACPI-Compliant System
 (ISA) 0x0000018A (394)	Microsoft ACPI-Compliant System
 (ISA) 0x0000018B (395)	Microsoft ACPI-Compliant System
 (ISA) 0x0000018C (396)	Microsoft ACPI-Compliant System
 (ISA) 0x0000018D (397)	Microsoft ACPI-Compliant System
 (ISA) 0x0000018E (398)	Microsoft ACPI-Compliant System
 (ISA) 0x0000018F (399)	Microsoft ACPI-Compliant System
 (ISA) 0x00000190 (400)	Microsoft ACPI-Compliant System
 (ISA) 0x00000191 (401)	Microsoft ACPI-Compliant System
 (ISA) 0x00000192 (402)	Microsoft ACPI-Compliant System
 (ISA) 0x00000193 (403)	Microsoft ACPI-Compliant System
 (ISA) 0x00000194 (404)	Microsoft ACPI-Compliant System

 (ISA) 0x00000195 (405)	Microsoft ACPI-Compliant System
 (ISA) 0x00000196 (406)	Microsoft ACPI-Compliant System
 (ISA) 0x00000197 (407)	Microsoft ACPI-Compliant System
 (ISA) 0x00000198 (408)	Microsoft ACPI-Compliant System
 (ISA) 0x00000199 (409)	Microsoft ACPI-Compliant System
 (ISA) 0x0000019A (410)	Microsoft ACPI-Compliant System
 (ISA) 0x0000019B (411)	Microsoft ACPI-Compliant System
 (ISA) 0x0000019C (412)	Microsoft ACPI-Compliant System
 (ISA) 0x0000019D (413)	Microsoft ACPI-Compliant System
 (ISA) 0x0000019E (414)	Microsoft ACPI-Compliant System
 (ISA) 0x0000019F (415)	Microsoft ACPI-Compliant System
 (ISA) 0x000001A0 (416)	Microsoft ACPI-Compliant System
 (ISA) 0x000001A1 (417)	Microsoft ACPI-Compliant System
 (ISA) 0x000001A2 (418)	Microsoft ACPI-Compliant System
 (ISA) 0x000001A3 (419)	Microsoft ACPI-Compliant System
 (ISA) 0x000001A4 (420)	Microsoft ACPI-Compliant System
 (ISA) 0x000001A5 (421)	Microsoft ACPI-Compliant System
 (ISA) 0x000001A6 (422)	Microsoft ACPI-Compliant System
 (ISA) 0x000001A7 (423)	Microsoft ACPI-Compliant System
 (ISA) 0x000001A8 (424)	Microsoft ACPI-Compliant System
 (ISA) 0x000001A9 (425)	Microsoft ACPI-Compliant System
 (ISA) 0x000001AA (426)	Microsoft ACPI-Compliant System
 (ISA) 0x000001AB (427)	Microsoft ACPI-Compliant System
 (ISA) 0x000001AC (428)	Microsoft ACPI-Compliant System
 (ISA) 0x000001AD (429)	Microsoft ACPI-Compliant System
 (ISA) 0x000001AE (430)	Microsoft ACPI-Compliant System
 (ISA) 0x000001AF (431)	Microsoft ACPI-Compliant System
 (ISA) 0x000001B0 (432)	Microsoft ACPI-Compliant System
 (ISA) 0x000001B1 (433)	Microsoft ACPI-Compliant System
 (ISA) 0x000001B2 (434)	Microsoft ACPI-Compliant System
 (ISA) 0x000001B3 (435)	Microsoft ACPI-Compliant System
 (ISA) 0x000001B4 (436)	Microsoft ACPI-Compliant System
 (ISA) 0x000001B5 (437)	Microsoft ACPI-Compliant System
 (ISA) 0x000001B6 (438)	Microsoft ACPI-Compliant System
 (ISA) 0x000001B7 (439)	Microsoft ACPI-Compliant System
 (ISA) 0x000001B8 (440)	Microsoft ACPI-Compliant System
 (ISA) 0x000001B9 (441)	Microsoft ACPI-Compliant System
 (ISA) 0x000001BA (442)	Microsoft ACPI-Compliant System
 (ISA) 0x000001BB (443)	Microsoft ACPI-Compliant System
 (ISA) 0x000001BC (444)	Microsoft ACPI-Compliant System
 (ISA) 0x000001BD (445)	Microsoft ACPI-Compliant System
 (ISA) 0x000001BE (446)	Microsoft ACPI-Compliant System
 (ISA) 0x000001BF (447)	Microsoft ACPI-Compliant System
 (ISA) 0x000001C0 (448)	Microsoft ACPI-Compliant System
 (ISA) 0x000001C1 (449)	Microsoft ACPI-Compliant System
 (ISA) 0x000001C2 (450)	Microsoft ACPI-Compliant System
 (ISA) 0x000001C3 (451)	Microsoft ACPI-Compliant System
 (ISA) 0x000001C4 (452)	Microsoft ACPI-Compliant System
 (ISA) 0x000001C5 (453)	Microsoft ACPI-Compliant System
 (ISA) 0x000001C6 (454)	Microsoft ACPI-Compliant System
 (ISA) 0x000001C7 (455)	Microsoft ACPI-Compliant System
 (ISA) 0x000001C8 (456)	Microsoft ACPI-Compliant System
 (ISA) 0x000001C9 (457)	Microsoft ACPI-Compliant System
 (ISA) 0x000001CA (458)	Microsoft ACPI-Compliant System
 (ISA) 0x000001CB (459)	Microsoft ACPI-Compliant System
 (ISA) 0x000001CC (460)	Microsoft ACPI-Compliant System
 (ISA) 0x000001CD (461)	Microsoft ACPI-Compliant System
 (ISA) 0x000001CE (462)	Microsoft ACPI-Compliant System
 (ISA) 0x000001CF (463)	Microsoft ACPI-Compliant System
 (ISA) 0x000001D0 (464)	Microsoft ACPI-Compliant System
 (ISA) 0x000001D1 (465)	Microsoft ACPI-Compliant System

 (ISA) 0x000001D2 (466)	Microsoft ACPI-Compliant System
 (ISA) 0x000001D3 (467)	Microsoft ACPI-Compliant System
 (ISA) 0x000001D4 (468)	Microsoft ACPI-Compliant System
 (ISA) 0x000001D5 (469)	Microsoft ACPI-Compliant System
 (ISA) 0x000001D6 (470)	Microsoft ACPI-Compliant System
 (ISA) 0x000001D7 (471)	Microsoft ACPI-Compliant System
 (ISA) 0x000001D8 (472)	Microsoft ACPI-Compliant System
 (ISA) 0x000001D9 (473)	Microsoft ACPI-Compliant System
 (ISA) 0x000001DA (474)	Microsoft ACPI-Compliant System
 (ISA) 0x000001DB (475)	Microsoft ACPI-Compliant System
 (ISA) 0x000001DC (476)	Microsoft ACPI-Compliant System
 (ISA) 0x000001DD (477)	Microsoft ACPI-Compliant System
 (ISA) 0x000001DE (478)	Microsoft ACPI-Compliant System
 (ISA) 0x000001DF (479)	Microsoft ACPI-Compliant System
 (ISA) 0x000001E0 (480)	Microsoft ACPI-Compliant System
 (ISA) 0x000001E1 (481)	Microsoft ACPI-Compliant System
 (ISA) 0x000001E2 (482)	Microsoft ACPI-Compliant System
 (ISA) 0x000001E3 (483)	Microsoft ACPI-Compliant System
 (ISA) 0x000001E4 (484)	Microsoft ACPI-Compliant System
 (ISA) 0x000001E5 (485)	Microsoft ACPI-Compliant System
 (ISA) 0x000001E6 (486)	Microsoft ACPI-Compliant System
 (ISA) 0x000001E7 (487)	Microsoft ACPI-Compliant System
 (ISA) 0x000001E8 (488)	Microsoft ACPI-Compliant System
 (ISA) 0x000001E9 (489)	Microsoft ACPI-Compliant System
 (ISA) 0x000001EA (490)	Microsoft ACPI-Compliant System
 (ISA) 0x000001EB (491)	Microsoft ACPI-Compliant System
 (ISA) 0x000001EC (492)	Microsoft ACPI-Compliant System
 (ISA) 0x000001ED (493)	Microsoft ACPI-Compliant System
 (ISA) 0x000001EE (494)	Microsoft ACPI-Compliant System
 (ISA) 0x000001EF (495)	Microsoft ACPI-Compliant System
 (ISA) 0x000001F0 (496)	Microsoft ACPI-Compliant System
 (ISA) 0x000001F1 (497)	Microsoft ACPI-Compliant System
 (ISA) 0x000001F2 (498)	Microsoft ACPI-Compliant System
 (ISA) 0x000001F3 (499)	Microsoft ACPI-Compliant System
 (ISA) 0x000001F4 (500)	Microsoft ACPI-Compliant System
 (ISA) 0x000001F5 (501)	Microsoft ACPI-Compliant System
 (ISA) 0x000001F6 (502)	Microsoft ACPI-Compliant System
 (ISA) 0x000001F7 (503)	Microsoft ACPI-Compliant System
 (ISA) 0x000001F8 (504)	Microsoft ACPI-Compliant System
 (ISA) 0x000001F9 (505)	Microsoft ACPI-Compliant System
 (ISA) 0x000001FA (506)	Microsoft ACPI-Compliant System
 (ISA) 0x000001FB (507)	Microsoft ACPI-Compliant System
 (ISA) 0x000001FC (508)	Microsoft ACPI-Compliant System
 (ISA) 0x000001FD (509)	Microsoft ACPI-Compliant System
 (ISA) 0x000001FE (510)	Microsoft ACPI-Compliant System
 (ISA) 0x000001FF (511)	Microsoft ACPI-Compliant System
 (PCI) 0x00000005 (05)	Intel(R) Atom(TM)/Celeron(R)/Pentium(R) Processor Trusted Execution Engine Interface - 0F18
 (PCI) 0x00000005 (05)	Intel(R) Atom(TM)/Celeron(R)/Pentium(R) Processor Platform Control Unit - SMBus Port - 0F12
 (PCI) 0x00000010 (16)	Intel(R) Atom(TM)/Celeron(R)/Pentium(R) Processor PCI Express - Root Port 1 - 0F48
 (PCI) 0x00000011 (17)	Intel(R) Atom(TM)/Celeron(R)/Pentium(R) Processor PCI Express - Root Port 2 - 0F4A
 (PCI) 0x00000012 (18)	Intel(R) Atom(TM)/Celeron(R)/Pentium(R) Processor PCI Express - Root Port 3 - 0F4C
 (PCI) 0x00000013 (19)	Intel(R) Atom(TM)/Celeron(R)/Pentium(R) Processor AHCI - 0F23
 (PCI) 0x00000013 (19)	Intel(R) Atom(TM)/Celeron(R)/Pentium(R) Processor PCI Express - Root Port 4 - 0F4E
 (PCI) 0x00000016 (22)	High Definition Audio Controller
 (PCI) 0xFFFFFFF7 (-9)	Intel(R) USB 3.0 eXtensible Host Controller - 0100 (Microsoft)
 (PCI) 0xFFFFFFF8 (-8)	Intel(R) HD Graphics
 (PCI) 0xFFFFFFF9 (-7)	Intel(R) I211 Gigabit Network Connection
 (PCI) 0xFFFFFFFA (-6)	Intel(R) I211 Gigabit Network Connection
 (PCI) 0xFFFFFFF8 (-5)	Intel(R) I211 Gigabit Network Connection
 (PCI) 0xFFFFFFF9 (-4)	Intel(R) I211 Gigabit Network Connection
 (PCI) 0xFFFFFFF8 (-3)	Intel(R) I211 Gigabit Network Connection
 (PCI) 0xFFFFFFF9 (-2)	Intel(R) I211 Gigabit Network Connection

# Appendix C

---

Programming Digital I/O

## C.1 DIO Programming

---

COM-BT-A30 utilizes AAEON chipset as its Digital I/O controller.

Below are the procedures to complete its configuration which you can develop customized program to fit your application.

## C.2 Digital I/O Register

	Default Value	Note
Index	0x284(Note1)	BRAM Index Register
Data	0x285(Note2)	BRAM Data Register
Logical Device Number	0xA2(Note3)	Watch dog Logical Device Number
Input/Output Function and Device Number	0x00(Note4)	DIO Input/Output Function/Device Number
Output Data Function and Device Number	0x01(Note5)	DIO Output Data Function/Device Number

	Register			
	Option Register	BitNum	Value	Note
GPI0 Pin Status	0x00(Note6)	0(Note7)	(Note15)	GPA2
GPI1 Pin Status	0x00(Note6)	1(Note8)	(Note16)	GPA3
GPI2 Pin Status	0x00(Note6)	2(Note9)	(Note17)	GPA4
GPI3 Pin Status	0x00(Note6)	3(Note10)	(Note18)	GPA5
GPO0 Pin Status	0x00(Note6)	4(Note11)	(Note19)	GPJ0
GPO1 Pin Status	0x00(Note6)	5(Note12)	(Note20)	GPJ1
GPO2 Pin Status	0x00(Note6)	6(Note13)	(Note21)	GPJ2
GPO3 Pin Status	0x00(Note6)	7(Note14)	(Note22)	GPJ3

## C.3 Digital I/O Sample Program

```
*****
// Embedded BRAM relative definition (Please reference to Table 1)
#define byte EcBRAMIndex //This parameter is represented from Note1
#define byte EcBRAMData //This parameter is represented from Note2
#define byte BRAMLDNReg //This parameter is represented from Note3
#define byte BRAMFnData0Reg //This parameter is represented from Note4
#define byte BRAMFnData1Reg //This parameter is represented from Note5
#define void EcBRAMWriteByte(byte Offset, byte Value);
#define byte EcBRAMReadByte(byte Offset);
#define void IOWriteByte(byte Offset, byte Value);
#define byte IOReadByte(byte Offset);
// Digital Input Status relative definition (Please reference to Table 2)
#define byte DIO0ToDIO7Reg // This parameter is represented from Note6
#define byte DIO0Bit // This parameter is represented from Note7
#define byte DIO1Bit // This parameter is represented from Note8
#define byte DIO2Bit // This parameter is represented from Note9
#define byte DIO3Bit // This parameter is represented from Note10
#define byte DIO4Bit // This parameter is represented from Note11
#define byte DIO5Bit // This parameter is represented from Note12
#define byte DIO6Bit // This parameter is represented from Note13
#define byte DIO7Bit // This parameter is represented from Note14
#define byte DIO0Val // This parameter is represented from Note15
#define byte DIO1Val // This parameter is represented from Note16
#define byte DIO2Val // This parameter is represented from Note17
#define byte DIO3Val // This parameter is represented from Note18
#define byte DIO4Val // This parameter is represented from Note19
#define byte DIO5Val // This parameter is represented from Note20
#define byte DIO6Val // This parameter is represented from Note21
#define byte DIO7Val // This parameter is represented from Note22
*****
```

```
*****
VOID Main(){
    Boolean PinStatus ;

    // Procedure : AaeonReadPinStatus
    // Input :
    //     Example, Read Digital I/O Pin 3 status
// Output :
//     InputStatus :
//         0: Digital I/O Pin level is low
//         1: Digital I/O Pin level is High
    PinStatus = AaeonReadPinStatus(DIO0ToDIO7Reg, DIO3Bit);

    // Procedure : AaeonSetOutputLevel
    // Input :
    //     Example, Set Digital I/O Pin 6 level
    AaeonSetOutputLevel(DIO0ToDIO7Reg, DIO6Bit, DIO6Val);
}
*****
```



```
*****
Boolean  AaeonReadPinStatus(byte OptionReg, byte BitNum){
    Byte TempByte;

    TempByte = ECBRAMReadByte(BRAMFnData1Reg, OptionReg);
    If (TempByte & BitNum == 0)
        Return 0;
    Return 1;
}
VOID  AaeonSetOutputLevel(byte OptionReg, byte BitNum, byte Value){
    Byte TempByte;

    TempByte = ECBRAMReadByte(BRAMFnData1Reg, OptionReg);
    TempByte |= (Value << BitNum);
    ECBRAMWriteByte(OptionReg, BitNum, Value);
}
*****
```

```

*****
VOID  ECBRAMWriteByte(byte OPReg, byte OPBit, byte Value){
    IOWriteByte(EcBRAMIndex, 0x10);
    IOWriteByte(EcBRAMData, BRAMLDNReg);
    IOWriteByte(EcBRAMIndex, 0x11);
    IOWriteByte(EcBRAMData, BRAMFnDataReg);

    IOWriteByte(EcBRAMIndex, 0x13 + OPReg);
    IOWriteByte(EcBRAMData, Value);

    IOWriteByte(EcBRAMIndex, 0x12);
    IOWriteByte(EcBRAMData, 0x30);          //Write start
}

Byte  ECBRAMReadByte(byte FnDataReg, byte OPReg){
    IOWriteByte(EcBRAMIndex, 0x10);
    IOWriteByte(EcBRAMData, BRAMLDNReg);
    IOWriteByte(EcBRAMIndex, 0x11);
    IOWriteByte(EcBRAMData, FnDataReg);

    IOWriteByte(EcBRAMIndex, 0x12);
    IOWriteByte(EcBRAMData, 0x10);        //Read start

    IOWriteByte(EcBRAMIndex, 0x13 + OPReg);
    Return    IOReadByte(EcBRAMData, Value);
}
*****

```