



BOXER-8653AI-PLUS

AI@Edge Compact Fanless Embedded
AI System with NVIDIA® Jetson Orin™ NX

User's Manual 1st Ed

Copyright Notice

This document is copyrighted, 2025. All rights are reserved. The original manufacturer reserves the right to make improvements to the products described in this manual at any time without notice.

No part of this manual may be reproduced, copied, translated, or transmitted in any form or by any means without the prior written permission of the original manufacturer. Information provided in this manual is intended to be accurate and reliable. However, the original manufacturer assumes no responsibility for its use, or for any infringements upon the rights of third parties that may result from its use.

The material in this document is for product information only and is subject to change without notice. While reasonable efforts have been made in the preparation of this document to assure its accuracy, AAEMON assumes no liabilities resulting from errors or omissions in this document, or from the use of the information contained herein.

AAEMON reserves the right to make changes in the product design without notice to its users.

Acknowledgements

All other products' name or trademarks are properties of their respective owners.

- NVIDIA®, the NVIDIA logo, Jetson™, Jetson Orin™ NX, and NVIDIA JetPack™ are trademarks of the NVIDIA Corporation.
- Arm® and Arm®v8-M architecture are registered trademarks of Arm Limited.
- Linux® is the registered trademark of Linus Torvalds in the U.S. and other countries.
- Ubuntu is a registered trademark of Canonical.

All other product names or trademarks are properties of their respective owners. No ownership is implied or assumed for products, names or trademarks not herein listed by the publisher of this document.

Packing List

Before setting up your product, please make sure the following items have been shipped:

Item	Quantity
● BOXER-8653AI-PLUS	1
● Wall Mount Bracket	2
● Screw Package	1
● Power Connector	1

If any of these items are missing or damaged, please contact your distributor or sales representative immediately.

About this Document

This User's Manual contains all the essential information, such as detailed descriptions and explanations on the product's hardware and software features (if any), its specifications, dimensions, jumper/connector settings/definitions, and driver installation instructions (if any), to facilitate users in setting up their product.

Users may refer to the product page at AAEON.com for the latest version of this document.

Safety Precautions

Please read the following safety instructions carefully. It is advised that you keep this manual for future references

1. All cautions and warnings on the device should be noted.
2. All cables and adapters supplied by AAEON are certified and in accordance with the material safety laws and regulations of the country of sale. Do not use any cables or adapters not supplied by AAEON to prevent system malfunction or fires.
3. Make sure the power source matches the power rating of the device.
4. Position the power cord so that people cannot step on it. Do not place anything over the power cord.
5. Always completely disconnect the power before working on the system's hardware.
6. No connections should be made when the system is powered as a sudden rush of power may damage sensitive electronic components.
7. If the device is not to be used for a long time, disconnect it from the power supply to avoid damage by transient over-voltage.
8. Always disconnect this device from any power supply before cleaning.
9. While cleaning, use a damp cloth instead of liquid or spray detergents.
10. Make sure the device is installed near a power outlet and is easily accessible.
11. Keep this device away from humidity.
12. Place the device on a solid surface during installation to prevent falls
13. Do not cover the openings on the device to ensure optimal heat dissipation.
14. Watch out for high temperatures when the system is running.
15. Do not touch the heat sink or heat spreader when the system is running
16. Never pour any liquid into the openings. This could cause fire or electric shock.

17. As most electronic components are sensitive to static electrical charge, be sure to ground yourself to prevent static charge when installing the internal components. Use a grounding wrist strap and contain all electronic components in any static-shielded containers.
18. If any of the following situations arises, please the contact our service personnel:
 - i. Damaged power cord or plug
 - ii. Liquid intrusion to the device
 - iii. Exposure to moisture
 - iv. Device is not working as expected or in a manner as described in this manual
 - v. The device is dropped or damaged
 - vi. Any obvious signs of damage displayed on the device
19. **DO NOT LEAVE THIS DEVICE IN AN UNCONTROLLED ENVIRONMENT WITH TEMPERATURES BEYOND THE DEVICE'S PERMITTED STORAGE TEMPERATURES (SEE CHAPTER 1) TO PREVENT DAMAGE.**

FCC Statement

Warning!



This device complies with Part 15 FCC Rules. Operation is subject to the following two conditions: (1) this device may not cause harmful interference, and (2) this device must accept any interference received including interference that may cause undesired operation.

Caution:

There is a danger of explosion if the battery is incorrectly replaced. Replace only with the same or equivalent type recommended by the manufacturer. Dispose of used batteries according to the manufacturer's instructions and your local government's recycling or disposal directives.

Attention:

Il y a un risque d'explosion si la batterie est remplacée de façon incorrecte. Ne la remplacer qu'avec le même modèle ou équivalent recommandé par le constructeur. Recycler les batteries usées en accord avec les instructions du fabricant et les directives gouvernementales de recyclage.

产品中有毒有害物质或元素名称及含量

AAEON System

QO4-381 Rev.A2

部件名称	有毒有害物质或元素					
	铅 (Pb)	汞 (Hg)	镉 (Cd)	六价铬 (Cr(VI))	多溴联苯 (PBB)	多溴二苯醚 (PBDE)
印刷电路板 及其电子组件	×	○	○	○	○	○
外部信号 连接器及线材	×	○	○	○	○	○
外壳	○	○	○	○	○	○
中央处理器 与内存	×	○	○	○	○	○
硬盘	×	○	○	○	○	○
液晶模块	×	○	○	○	○	○
光驱	×	○	○	○	○	○
触控模块	×	○	○	○	○	○
电源	×	○	○	○	○	○
电池	×	○	○	○	○	○

本表格依据 SJ/T 11364 的规定编制。

○：表示该有毒有害物质在该部件所有均质材料中的含量均在 GB/T 26572 标准规定的限量要求以下。

×：表示该有害物质的某一均质材料超出了 GB/T 26572 的限量要求，然而该部件仍符合欧盟指令 2011/65/EU 的规范。

环保使用期限(EFUP (Environmental Friendly Use Period))：10 年

备注：

一、此产品所标示之环保使用期限，系指在一般正常使用状况下。

二、上述部件物质中央处理器、内存、硬盘、光驱、电源为选购品。

三、上述部件物质液晶模块、触控模块仅一体机产品适用。

China RoHS Requirement (EN)

Name and content of hazardous substances in product

AAEON System

QO4-381 Rev.A2

Part Name	Hazardous Substances					
	铅 (Pb)	汞 (Hg)	镉 (Cd)	六价铬 (Cr(VI))	多溴联苯 (PBB)	多溴二苯醚 (PBDE)
PCB Assemblies	×	○	○	○	○	○
Connector and Cable	×	○	○	○	○	○
Chassis	○	○	○	○	○	○
CPU and Memory	×	○	○	○	○	○
Hard Disk	×	○	○	○	○	○
LCD Modules	×	○	○	○	○	○
CD-ROM/DVD-ROM	×	○	○	○	○	○
Touch Modules	×	○	○	○	○	○
Power	×	○	○	○	○	○
Battery	×	○	○	○	○	○

The table is prepared in accordance with the provisions of SJ/T 11364.

○ : Indicates that said hazardous substance contained in all of the homogenous materials for this product is below the limit requirement of GB/T 26572.

× : Indicates that said hazardous substance contained in at least one of the homogenous materials used for this part is above the limit requirement of GB/T 26572. But this product still be compliance with 2011/65/EU Directive (allowed with 2011/65/EU Annex III of RoHS exemption with number 6(c),7(a),7(c)-1).

EFUP (Environment Friendly Use Period) value: 10 years.

Notes:

1. This product defined period of use is under normal condition.
2. In above part, CPU/Memory/ Hard Disk/CD-ROM/DVD-ROM/ Power are optional.
3. In above part, LCD Modules/ Touch Modules are for all-in-one product model.

Table of Contents

Chapter 1 - Product Specifications	1
1.1 Specifications	2
Chapter 2 – Hardware Information	4
2.1 Dimensions	5
2.2 Jumpers and Connectors.....	6
2.3 List of Jumpers	8
2.3.1 Jumper Settings	8
2.3.2 AT/ATX Mode Selection (JP1)	9
2.4 List of Connectors.....	10
2.4.1 Front Panel Connector (CN24)	11
2.4.2 RTC Battery Connector (CN2).....	12
2.4.3 Micro USB 2.0 for Flash Connector (CN4)	12
2.4.4 HDMI Connector (CN5)	13
2.4.5 M.2 2280 M-Key (CN28).....	14
2.4.6 M.2 3042/3052 B-Key (CN12)	15
2.4.7 M.2 2230 E-Key (CN10)	17
2.4.8 USB 3.2 Gen 2 Connector (CN31/CN32)	18
2.4.9 RJ-45 LAN (CN19)	19
2.4.10 RJ-45 LAN (PoE) (CN17/CN18/CN29/CN30).....	20
2.4.11 DC in Connector (5.0mm) (CN26)	21
2.4.12 RS-232/422/485 Connector (CN6).....	21
2.4.13 RS-232 & DIO Connector (CN8)	22
2.4.14 RS-232/422/485 Select (SW1).....	23
2.4.15 MIPI CSI 0-1 Connector (CN35/CN36).....	24
2.4.16 SATA Connector (CN33).....	25
2.5 Hardware Installation	26

2.5.1	Expansion Module Installation.....	26
2.5.2	Wall Mount Installation.....	28
Chapter 3 – BSP Flash Guide.....		29
3.1	Before Installation.....	30
3.2	Connecting to PC/Force Recovery Mode	31
3.3	Flash Image to Board.....	33
3.4	Check BSP Version.....	34
Chapter 4 – OS User Guide.....		35
4.1	Introduction	36
4.2	Update Note.....	37
4.3	BOXER-8653AI-PLUS Power Mode.....	37
4.4	DIO Command Setting for BOXER-8653AI-PLUS.....	39

Chapter 1

Product Specifications

1.1 Specifications

System

AI Accelerator	NVIDIA® Jetson Orin NX™ with Super Mode
CPU	8GB SKU: 6-core Arm® Cortex®-A78AE v8.2 64-bit CPU 16GB SKU: 8-core Arm® Cortex®-A78AE v8.2 64-bit CPU
System Memory	8GB/16GB LPDDR5 (Dependent on AI Accelerator Module)
Storage Device	M.2 2280 M-Key (pre-populated by 128GB NVMe)
Display Interface	HDMI 1.2 x 1
Ethernet	RJ-45 x 1 for GbE LAN RJ-45 x 4 for GbE LAN PoE/PSE (IEEE 802.3af/at, total 60W)
I/O	USB 3.2 Gen 2 (Type-A) x 4 DB-9 for RS-232 (Rx/Tx/CTS/RTS) & CANBus FD x 1 DB-15 for RS-422/485/232 (Rx/Tx) x 1 & DIO x 8 Micro USB x 1 for OS Flash Recovery Button x 1 Antenna x 6
Expansion	M.2 3042/3052 B-Key x 1 (LTE/5G/M.2 2242 B+M-Key storage) M.2 2230 E-Key x 1 (Wi-Fi/BT) M.2 2280 M-Key x 1 (pre-populated by 128GB NVMe) Nano SIM Card Slot x 1 Box Header x 1 for OOB
Indicator	Power LED x 1

System

OS Support Linux (NVIDIA Jetpack™ 6.2 and above)

Power Supply

Power Requirement 12VDC – 24VDC via 2-pin Terminal Block

Mechanical

Mounting Wall Mount

Dimensions (W x D x H) 7.48" × 5.35" × 2.95" (190mm x 136mm x 75mm)

Gross Weight 7.41 lb (3.36 kg)

Net Weight 5.51 lb (2.5 kg)

Environmental

Operating Temperature -13°F – 149°F (-25°C – 65°C with 0.7m/s airflow)

Storage Temperature -40°F – 185°F (-40°C – 85°C)

Storage Humidity 5 – 95% @ 40°C, non-condensing

Anti-Vibration 3.5 Grms, 5~500Hz with SSD

Anti-Shock 50G peak acceleration with SSD

Certification CE / FCC Class A

Chapter 2

Hardware Information

2.1 Dimensions

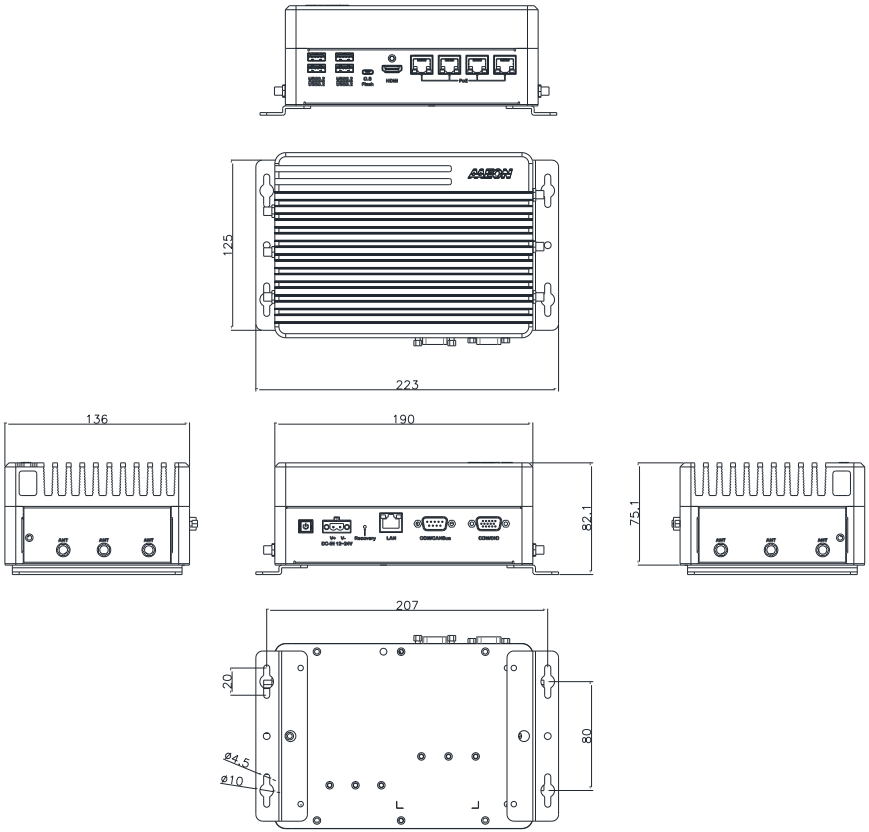

2.2 Jumpers and Connectors

Top View

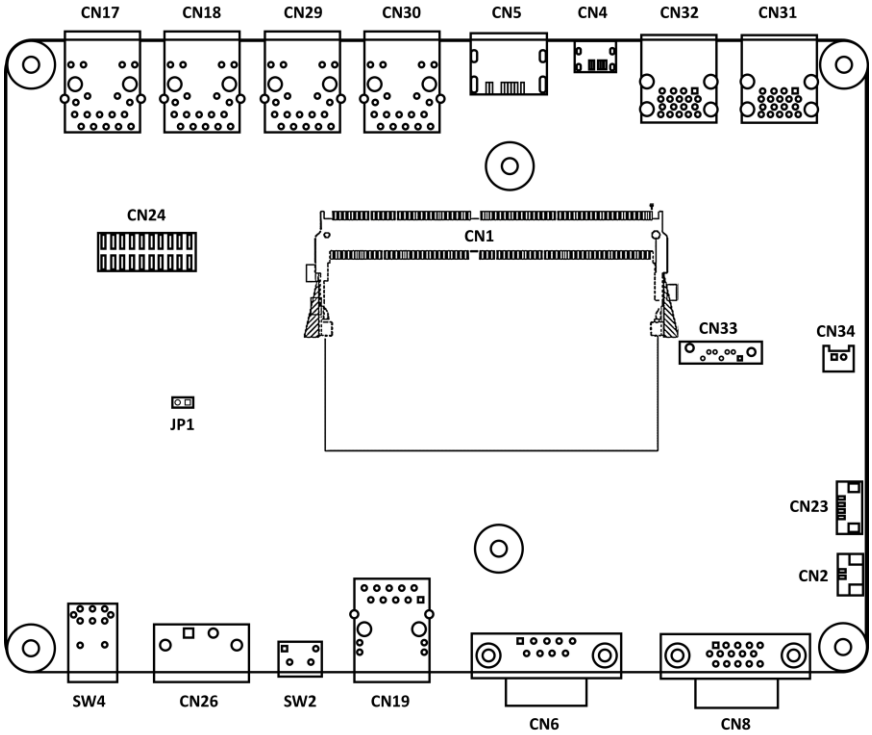

Bottom View

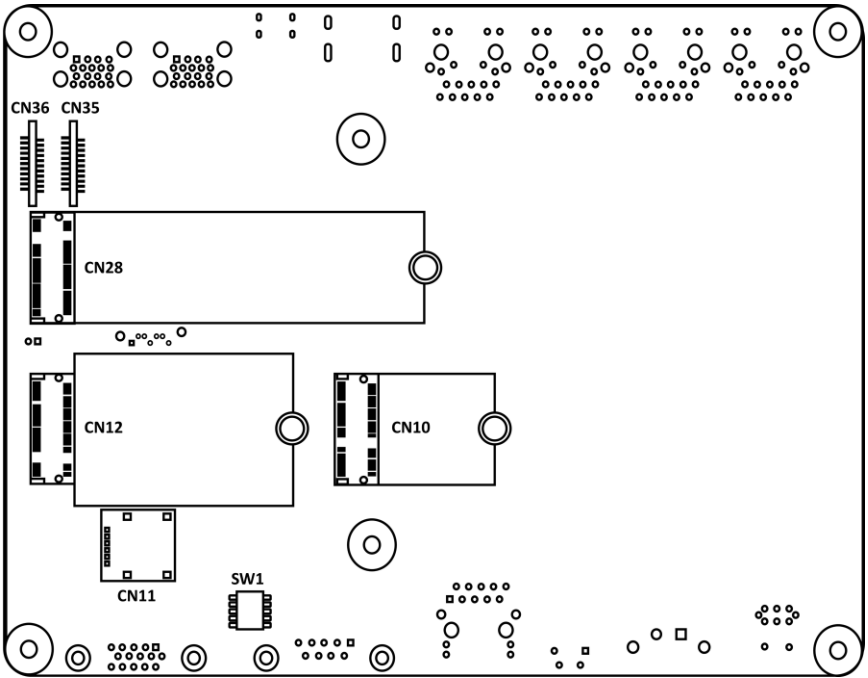

2.3 List of Jumpers

The system has a number of jumpers that allow you to configure your system to suit your application.

The table below shows the function of each of the board's jumpers

Label	Function
JP1	AT/ATX Mode Selection

2.3.1 Jumper Settings

You configure your card to match the needs of your application by setting jumpers. A jumper is the simplest kind of electric switch. It consists of two metal pins and a small metal clip (often protected by a plastic cover) that slides over the pins to connect them. To "close" a jumper you connect the pins with the clip.

To "open" a jumper you remove the clip. Sometimes a jumper will have three pins, labeled 1, 2 and 3. In this case you would connect either pins 1 and 2 or 2 and 3.

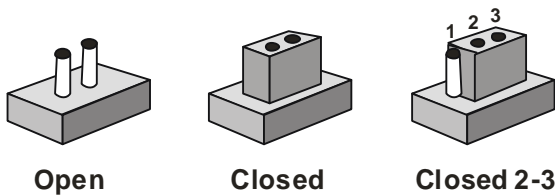

A pair of needle-nose pliers may be helpful when working with jumpers.

If you have any doubts about the best hardware configuration for your application, contact your local distributor or sales representative before you make any change.

Generally, you simply need a standard cable to make most connections.

2.3.2 AT/ATX Mode Selection (JP1)

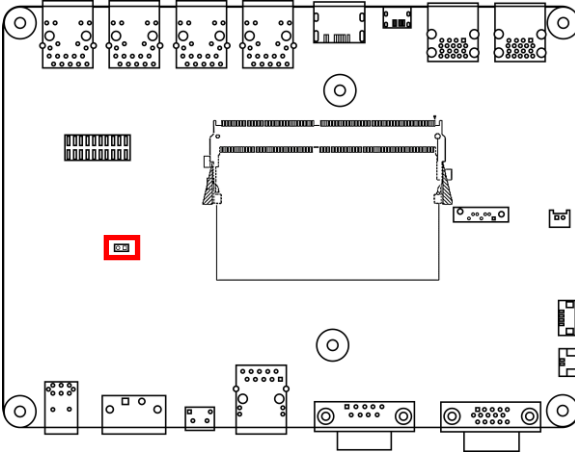

Open AT



Close ATX (Default)

JP1 Pin	Function
1-2	Open AT
1-2	Close ATX (Default)

2.4 List of Connectors

The system has a number of ports that allow you to configure your system to suit your application.

The table below shows the function of each of the board's connectors.

Note: Not all PCB-level internal connector pins listed are accessible via the system's external ports. For detailed specifications please refer to Chapter 1.

Label	Function
CN1	Jetson Orin NX Connector
CN2	RTC Battery Connector
CN4	Micro USB 2.0 for Flash Connector
CN5	HDMI Connector
CN6	RS-232/422/485 Connector
CN8	RS-232 & DIO Connector
CN10	M.2 2230 E-Key
CN11	Nano SIM Slot
CN12	M.2 3042/3052 B-Key
CN17	RJ-45 LAN (PoE) (ETH1)
CN18	RJ-45 LAN (PoE) (ETH0)
CN19	RJ-45 LAN (ETH4)
CN23	Fan Connector
CN24	Front Panel + NC SI
CN26	DC in Connector (5.0mm)
CN28	M.2 2280 M-Key
CN29	RJ-45 LAN (PoE) (ETH3)
CN30	RJ-45 LAN (PoE) (ETH2)
CN31	USB 3.2 Gen 2 Connector
CN32	USB 3.2 Gen 2 Connector
CN33	SATA Connector
CN34	SATA Power Connector (5V)
CN35	MIPI CSI Connector
CN36	MIPI CSI Connector
SW1	RS-232/422/485 Select
SW2	Recovery Button
SW4	Power Button
JP1	AT/ATX Mode Selection

2.4.1 Front Panel Connector (CN24)

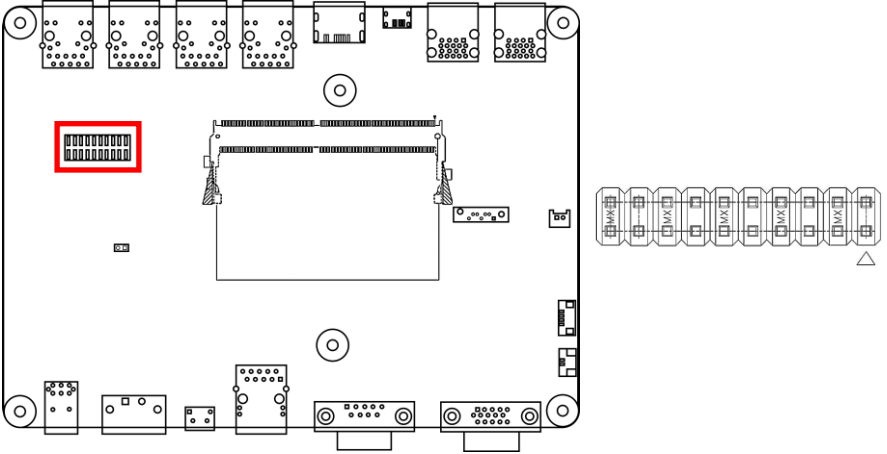

Pin	Signal	Pin	Signal
1	PWR_LED	2	5V
3	Debug UART TX	4	NC_SI_TXD0
5	Debug UART RX	6	NC_SI_TXD1
7	I2C1 SCL	8	NC_SI_RXD0
9	I2C1 SDA	10	NC_SI_RXD1
11	System Reset	12	NC_SI_CLK_IN
13	Button power	14	NC_SI_CRB
15	GND	16	NC_SI_TX_EN

2.4.2 RTC Battery Connector (CN2)

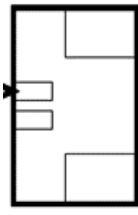
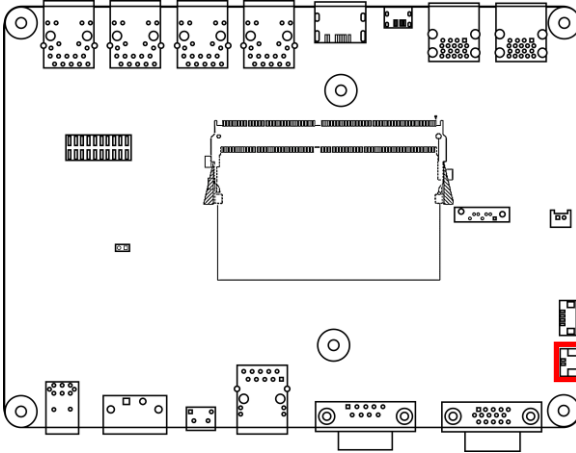

Pin	Signal	Pin	Signal
1	Positive	2	Negative

2.4.3 Micro USB 2.0 for Flash Connector (CN4)

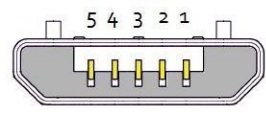
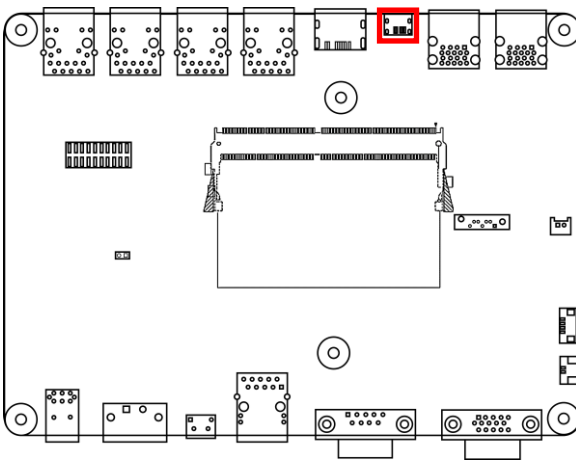

USB Micro-B

Pin	Signal	Pin	Signal
1	+5V	2	USB1-
3	USB1+	4	

Pin	Signal	Pin	Signal
5	GND		

2.4.4 HDMI Connector (CN5)

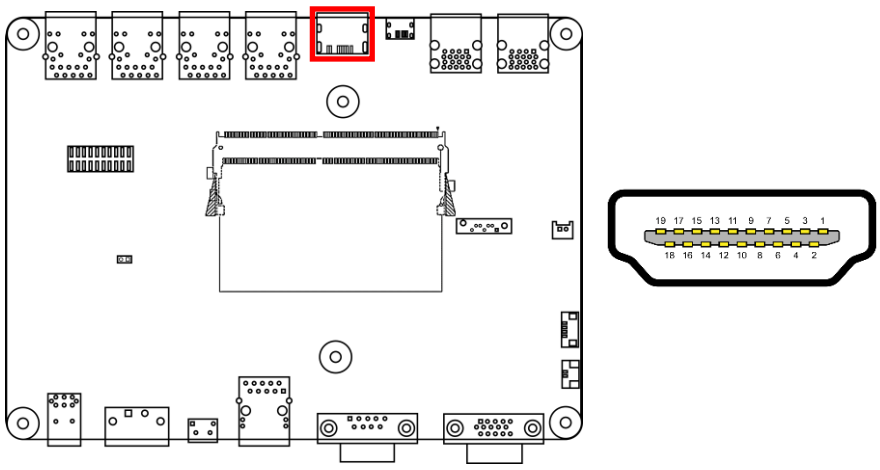

Pin	Signal	Pin	Signal
1	HDMI_DATA2_P	2	GND
3	HDMI_DATA2_N	4	HDMI_DATA1_P
5	GND	6	HDMI_DATA1_N
7	HDMI_DATA0_P	8	GND
9	HDMI_DATA0_N	10	HDMI_CLK_P
11	GND	12	HDMI_CLK_N
13	NC	14	NC
15	HDMI_SCL	16	HDMI_SDA
17	GND	18	HDMI_PWR
19	HDMI_HDP		

2.4.5 M.2 2280 M-Key (CN28)

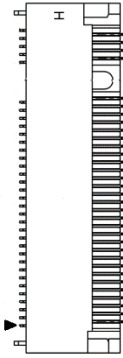
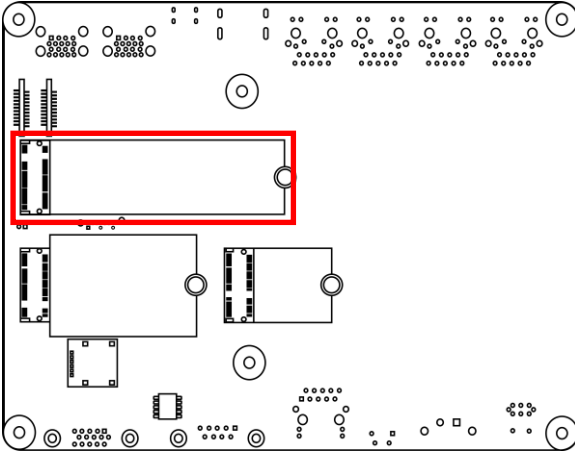

Pin	Signal	Signal	Pin
74	3.3 V	GND	75
72	3.3 V	GND	73
70	3.3 V	GND	71
68	SUSCLK	PEDET	69
		NC	67
	Key M	Key M	
	Key M	Key M	
	Key M	Key M	
	Key M	Key M	
58	NC	GND	57
56	NC	REFCLKp	55
54	PEWAKE#	REFCLKn	53
52	CLKREQ#	GND	51
50	PERST#	PETp0	49
48	NC	PETn0	47
46	NC	GND	45
44	ALERT#	PERp0	43
42	SMB_DATA	PERn0	41
40	SMB_CLK	GND	39
38	DEVSLP	PETp1	37
36	NC	PETn1	35
34	NC	GND	33

Pin	Signal	Signal	Pin
32	NC	PERp1	31
30	NC	PERn1	29
28	NC	GND	27
26	NC	PETp2	25
24	NC	PETn2	23
22	NC	GND	21
20	NC	PERp2	19
18	3.3 V	PERn2	17
16	3.3 V	GND	15
14	3.3 V	PETp3	13
12	3.3 V	PETn3	11
10	DAS/DSS	GND	9
8	NC	PERp3	7
6	NC	PERn3	5
4	3.3 V	GND	3
2	3.3 V	GND	1

2.4.6 M.2 3042/3052 B-Key (CN12)

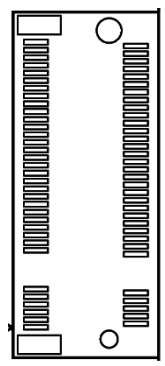
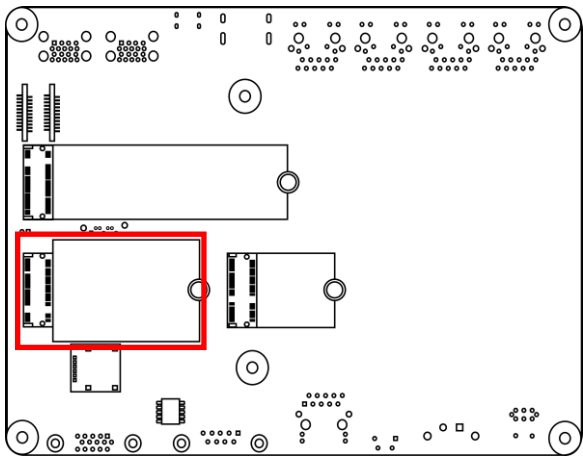

Pin	Signal	Signal	Pin
74	3.3 V	CONFIG_2	75
72	3.3 V	GND	73
70	3.3 V	GND	71
68	SUSCLK(32kHz)	CONFIG_1	69

Pin	Signal	Signal	Pin
66	SIM_DETECT	RESET#	67
64	COEX_RXD	ANTCTL3	65
62	COEX_TXD	ANTCTL2	63
60	COEX3	ANTCTL1	61
58	NC	ANTCTL0	59
56	NC	GND	57
54	PEWAKE#	PCIE_CLK_P	55
52	CLKREQ#	PCIE_CLK_N	53
50	PERST#	GND	51
48	NC	PCIE_TX_P	49
46	NC	PCIE_TX_N	47
44	NC	GND	45
42	NC	PCIE_RX_P	43
40	NC	PCIE_RX_N	41
38	NC	GND	39
36	UIM1-PWR	USB3.1-Tx+	37
34	UIM1-DATA	USB3.1-Tx-	35
32	UIM1-CLK	GND	33
30	UIM1-RESET	USB3.1-Rx+	31
28	GPIO_8	USB3.1-Rx-	29
26	GPIO_10	GND	27
24	GPIO_7	DPR	25
22	GPIO_6	GPIO_11	23
20	GPIO_5	CONFIG_0	21
		Key B	
		Key B	
		Key B	
		Key B	
		GND	11
10	GPIO_9/DAS/DSS/LED_1#	USB_D-	9
8	W_DISABLE1#	USB_D+	7
6	FULL_CARD_POWER_OFF#	GND	5
4	3.3 V	GND	3
2	3.3 V	CONFIG_3	1

2.4.7 M.2 2230 E-Key (CN10)

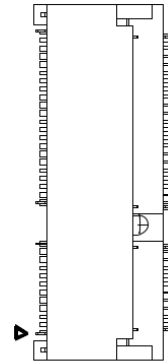
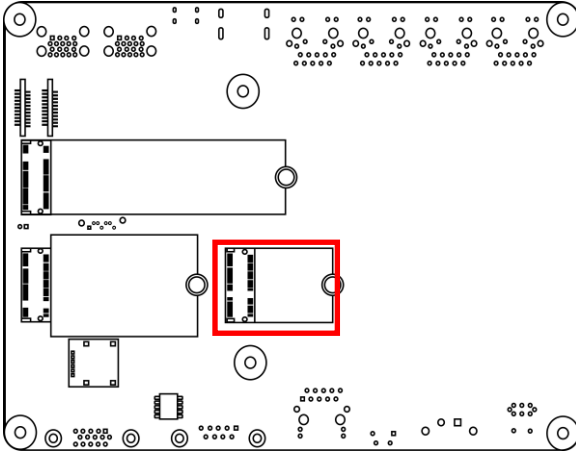

Pin	Signal	Signal	Pin
74	3.3V	GND	75
72	3.3V	RESERVED/REFCLKn1	73
70	NC	RESERVED/REFCLKp1	71
68	NC	GND	69
66	NC	RESERVED/PERn1	67
64	RESERVED	RESERVED/PERp1	65
62	ALERT#	GND	63
60	I2C_CLK	RESERVED/PETn1	61
58	I2C_DATA	RESERVED/PETp1	59
56	W_DISABLE1#	GND	57
54	W_DISABLE2#	PEWAKE0#	55
52	PERST0#	CLKREQ0#	53
50	SUSCLK(32kHz)	GND	51
48	NC	REFCLKn0	49
46	NC	REFCLKp0	47
44	NC	GND	45
42	NC	PERn0	43
40	NC	PERp0	41
38	NC	GND	39
36	NC	PETn0	37
34	NC	PETp0	35
32	NC	GND	33

Pin	Signal	Signal	Pin
		Key E	
		Key E	
		Key E	
		Key E	
		NC	23
22	NC	NC	21
20	UART WAKE#	NC	19
18	GND	NC	17
16	NC	NC	15
14	I2S SD_OUT	NC	13
12	I2S SD_IN	NC	11
10	I2S WS	NC	9
8	I2S SCK	GND	7
6	NC	USB_D-	5
4	3.3V	USB_D+	3
2	3.3V	GND	1

2.4.8 USB 3.2 Gen 2 Connector (CN31/CN32)

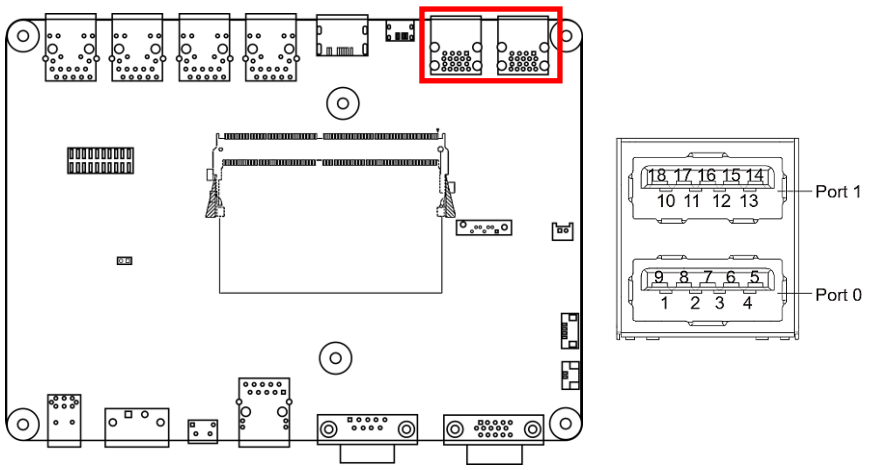

Pin	Signal	Pin	Signal
U1	VBUS_1	U10	VBUS_2
U2	(A)D-	U11	(B)D-
U3	(A)D+	U12	(B)D+
U4	GND	U13	GND

Pin	Signal	Pin	Signal
U5	(A)SSRX-	U14	(B)SSRX-
U6	(A)SSRX+	U15	(B)SSRX+
U7	GND	U16	GND
U8	(A)SSTX-	U17	(B)SSTX-
U9	(A)SSTX+	U18	(B)SSTX+

2.4.9 RJ-45 LAN (CN19)

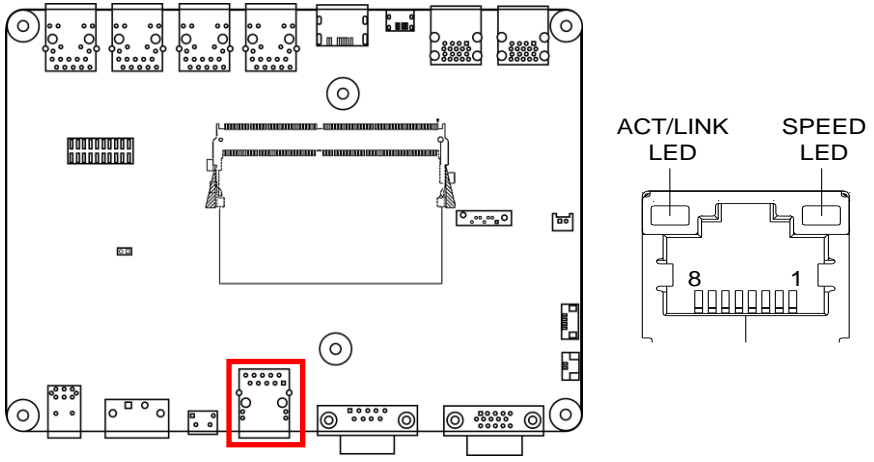

Pin	Signal	Pin	Signal
1	MDI0+	2	MDI0-
3	MDI1+	4	MDI1-
5	MDI2+	6	MDI2-
7	MDI3+	8	MDI3-
1	Active LED	2	Speed LED
Orange	Blinking	NA	100Mbps
		Orange	1Gbps -

2.4.10 RJ-45 LAN (PoE) (CN17/CN18/CN29/CN30)

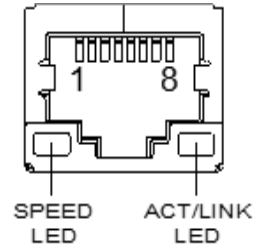
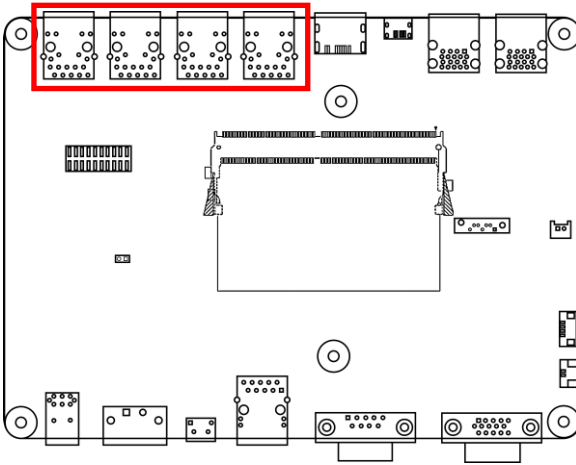

Pin	Signal	Pin	Signal
1	MDI0+	2	MDI0-
3	MDI1+	4	MDI1-
5	MDI2+	6	MDI2-
7	MDI3+	8	MDI3-
1	Active LED	2	Speed LED
Orange	Blinking	NA	100Mbps
		Orange	1Gbps -

2.4.11 DC in Connector (5.0mm) (CN26)

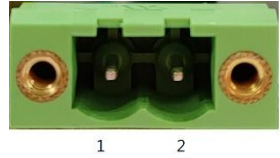
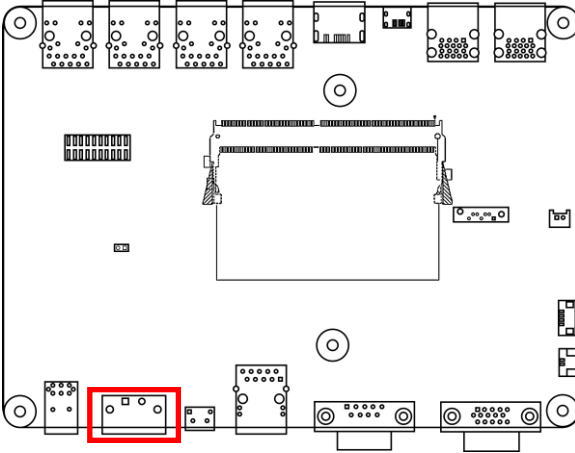

Pin	Signal	Pin	Signal
1	DC Positive	2	DC Negative

2.4.12 RS-232/422/485 Connector (CN6)

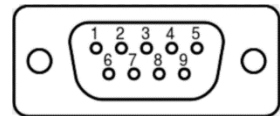
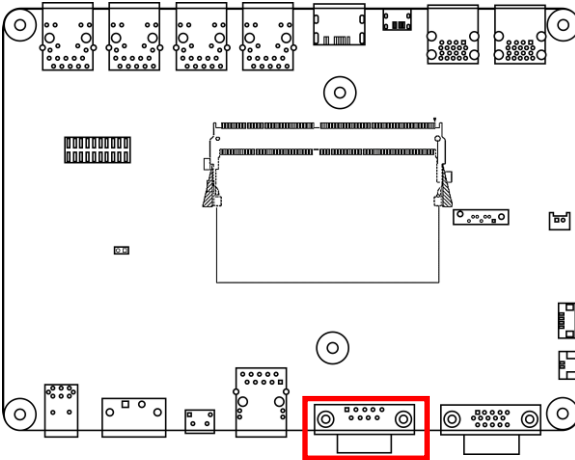

Pin	RS-232	RS-422	RS-485
1		TX-	D-
2	RXD	TX+	D+

Pin	RS-232	RS-422	RS-485
3	TXD	RX+	
4		RX-	
5	GND		
6	CAN_L		
7	RTSD		
8	CTSD		
9	CAN_H		

2.4.13 RS-232 & DIO Connector (CN8)

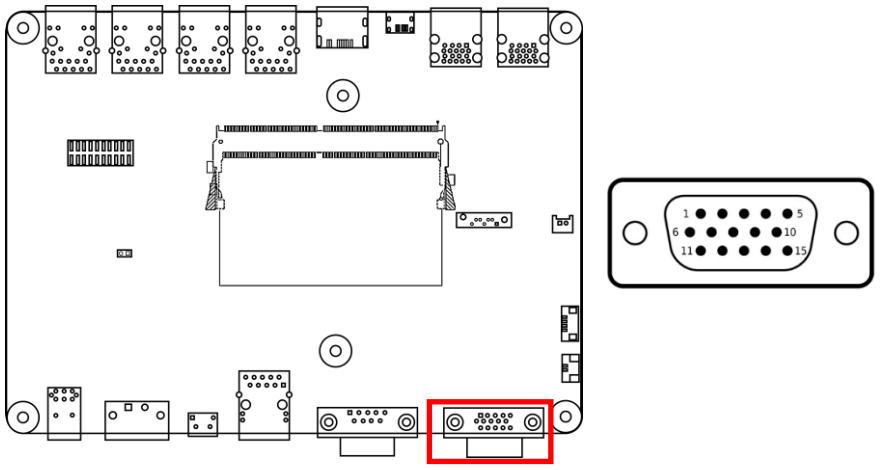

Pin	RS-232	GPIO	Voltage level (Logic High)
1	RXD		3.3V
2	TXD		3.3V
3	RTS		3.3V
4	CTS		3.3V
5	GND		GND
6		PZ.03	3.3V
7		PZ.04	3.3V
8		PZ.05	3.3V
9		PZ.06	3.3V
10	GND	GND	GND
11		PI.02	3.3V
12		PI.01	3.3V

Pin	RS-232	GPIO	Voltage level (Logic High)
13		PI.00	3.3V
14		PH.07	3.3V
15	GND	GND	GND

DIO (GPIO):
 Drive current: 15mA
 All Logical Level: +3.3V

2.4.14 RS-232/422/485 Select (SW1)

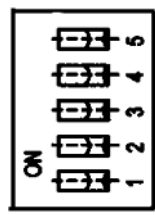
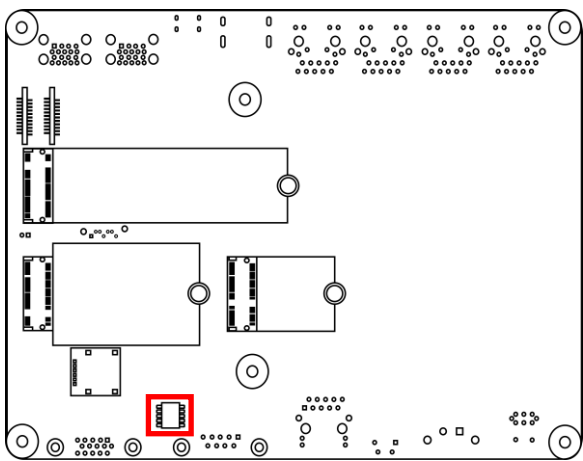

Mode	S-1	S-2	S-3	S-4	S-5
2T/2R RS-232	On	On	On		
1T/1R RS-422 Full Duplex w/o RTS#, TX always enable	On	On	Off		
1T/1R RS-422 Full Duplex TX enable low active with auto sensing	On	Off	On		
1T/1R RS-422 Full Duplex TX enable when RTS# is low.	On	Off	Off		
1T/1R RS-485 Half Duplex TX enable low active with auto sensing	Off	On	On		

Mode	S-1	S-2	S-3	S-4	S-5
1T/1R RS-485 Half Duplex	Off	On	Off		
TX enable when RTS# is low.					
Low power shutdown	Off	Off	On		
250kbps for RS-232 and RS-485					On
RS-232 to 3Mbps and RS-485 to 20Mbps					Off
Enable RS-485 bias and termination resistors.				On	
Disable RS-485 bias and termination resistors.				Off	

2.4.15 MIPI CSI 0-1 Connector (CN35/CN36)

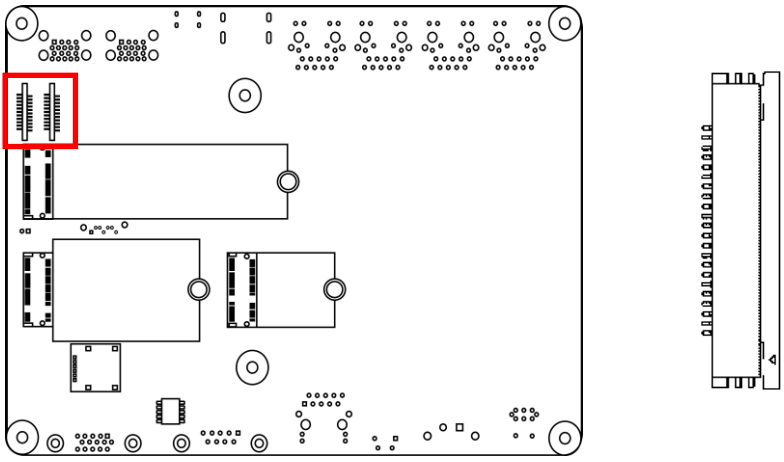

Pin	Signal	Pin	Signal
1	+3.3V	12	CSI0_D0_N
2	CAM0 SDA	13	GND
3	CAM0 SCL	14	CSI1_CLK_P
4	GND	15	CSI1_CLK_N
5	CAM0 MCLK	16	GND
6	CAM0 PWDN	17	CSI1_D1_P
7	GND	18	CSI1_D1_N
8	CSI0_D1_P	19	GND
9	CSI0_D1_N	20	CSI1_D0_P
10	GND	21	CSI1_D0_N
11	CSI0_D0_P	22	GND

2.4.16 SATA Connector (CN33)

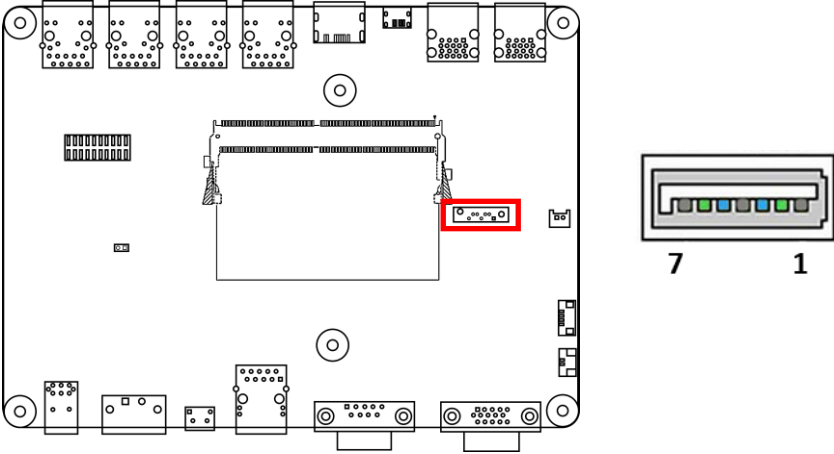

Pin	Signal
1	GND
2	TX+
3	TX-
4	GND
5	RX+
6	RX-
7	GND

2.5 Hardware Installation

2.5.1 Expansion Module Installation

- To access the BOXER-8653AI-Plus system's expansion slots, remove the eight (8) M3 screws located as shown on the bottom panel.

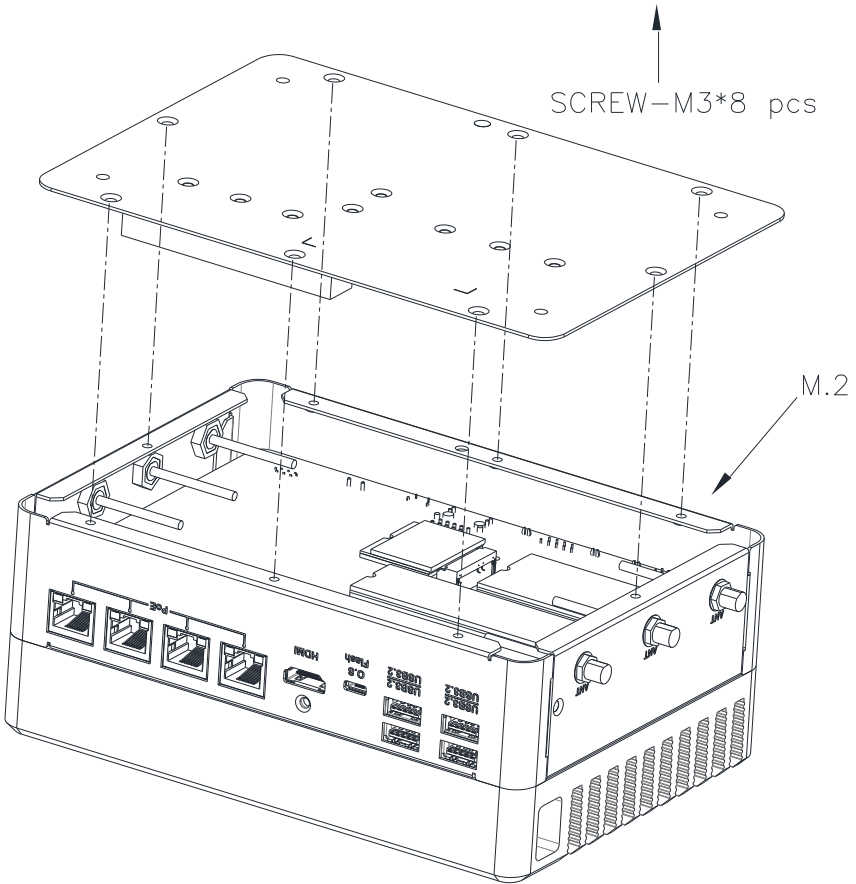

- Note the location of each expansion slot as per the below diagram.

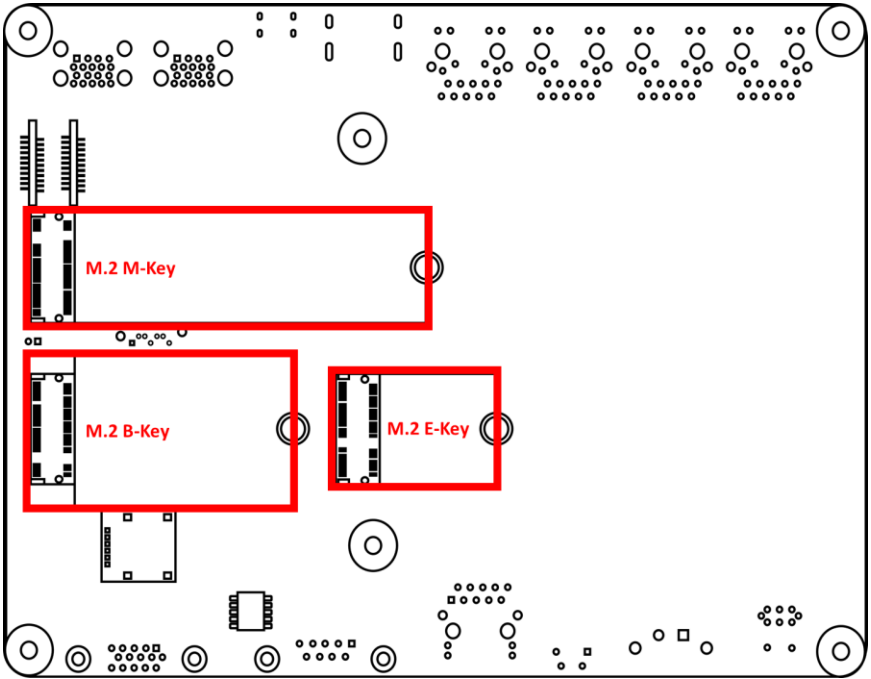

- Install each module by first inserting at an angle (approx. 30°), then gently pressing down and securing.

2.5.2 Wall Mount Installation

- Turn the BOXER-8653AI-Plus system over so the bottom is facing up.
- Install each bracket using two (2) M4 screws (four in total) to affix them to the bottom of the chassis, as below.

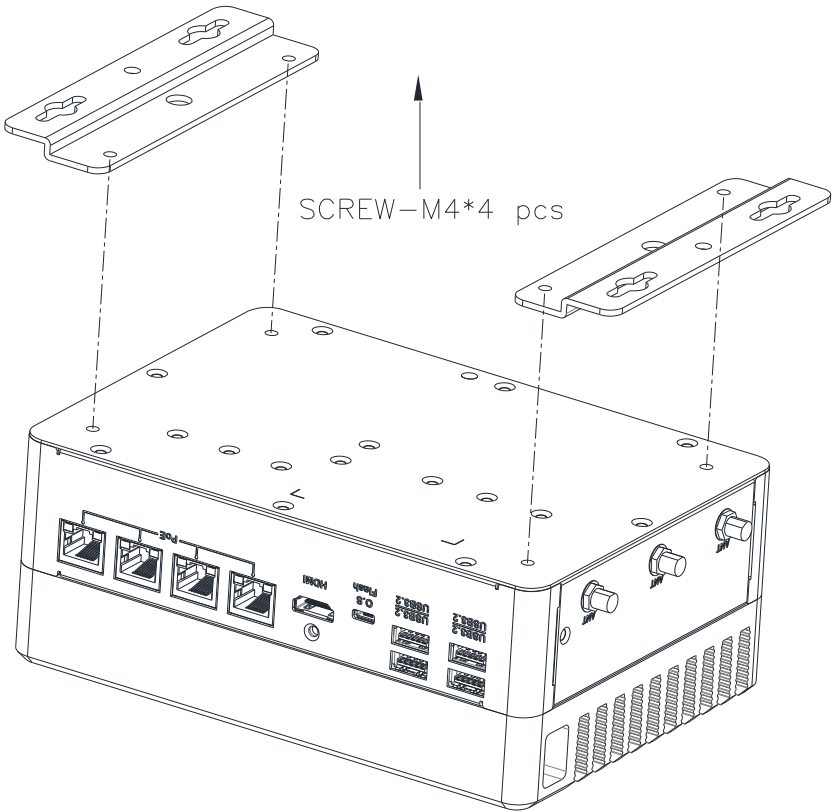

Chapter 3

BSP Flash Guide

3.1 Before Installation

Before starting the process, make sure that your BOXER-8653AI-Plus system is powered off and the power cable is disconnected. You will need a host PC running Ubuntu 20.04 or Ubuntu 22.04. Also, ensure that the NVIDIA Jetson Orin NX module is properly installed on the BOXER-8653AI-Plus carrier board.

Note: Do not use a virtual machine as a host PC, as some virtual machines may have unstable USB connections which can cause the flash procedure to fail.



Download the compressed BSP image file:

["BOXER-8653AI-B1_J6.2.1_A00_1.0.0_20251103.tar.gz"](#) to a directory on the host PC running Ubuntu 20.04 or Ubuntu 22.04.

Note: Spaces, special characters, and non-English characters are not allowed in the name of the folder where the file is stored, or in any parent folders.

Please set the Ubuntu 18.04 or 20.04 system language to English and the region format to United States to avoid flashing failures.

3.2 Connecting to PC/Force Recovery Mode

Step 1:

On the Host computer, open Linux terminal and enter the following command to extract the compressed BSP image files (BSP file name may vary):

```
$ sudo tar xzf BOXER-8653AI-B1_J6.2.1_A00_1.0.0_20251103.tar.gz
```

Note: Do not decompress the BSP file on a Windows system. The BSP file must be extracted on a Linux system using an EXT3 or EXT4 file system.

Step 2:

Perform the following actions to force the system to start in USB Recovery Mode:

1. Connect the Micro-USB connector of the USB cable to the Flash Port on the BOXER-8653AI-Plus, and connect the other end to an available USB port on the host PC.
2. Connect the BOXER-8653AI-Plus power supply.
3. Press and hold the Recovery button. While holding the button, power on the system and continue holding it for about two seconds before releasing. The BOXER-8653AI-Plus should then enter into Force Recovery Mode.
4. To check if device is in recovery mode, enter the **lsusb** command in the terminal on the Host PC. The Jetson module is in Force Recovery Mode if you see the following message:

```
$ lsusb | grep "Nvidia Corp"
```

If successful, the command will return the following:

```
Bus <bbb> Device <ddd>: ID 0955: <nxxx> Nvidia Corp
```

Where:

- **<nnnn>** is a four-digit number that represents your module type
 - 7323 for Jetson Orin NX (P3767-0000 with 16GB)
 - 7423 for Jetson Orin NX (P3767-0001 with 8GB)

Note: Recovery Mode cannot be initiated if the Jetson Orin NX module is disassembled. Ensure that the NVIDIA Jetson Orin NX module is properly installed, and refer to the image below to perform the steps:



3.3 Flash Image to Board

Use the following steps to flash the OS to the BOXER-8653AI-Plus.

1. Open terminal on the Ubuntu Host PC, then access the folder you extracted in the previous section.
2. Enter the following command in the terminal to flash and build the image for the first time:

```
$ ./flashboxer.sh -s 62517420 nvme
```

3. Wait until the image is installed. Once finished you should see the following:

```
tar: Read checkpoint 660000
tar: Read checkpoint 670000
writing litem17_910:secondary.gpt, 320000021d4, 16896, gpt_secondary_9_0.bin, 16896, flxed--reserved-0, 99780b7732fdef330529d8178dfa2cf89e3298c
[ 597]: ldt_flash_from_kernel: Successfully flash the external device
[ 597]: ldt_flash_from_kernel: Flashing success
Flash is successful
Reboot device
Cleaning up...
Log is saved to linux_for_Tegra/lntrdlog/flash_1-2_0_20240410-165418.log
Flash target board success
```

4. For the second time and onwards, you can flash up to 10 targets (depends on your computer capability) at once. Use the following command:

```
$ ./flashboxer.sh -m nvme
```

3.4 Check BSP Version

Once the flash image is successfully installed, the BOXER-8653AI-Plus will reboot automatically, then check the BSP version to see if the system is flashing the correct version of BSP.

Open a Terminal, and type command "`cat /proc/product`"

You will see the product name with version and date

```
BOXER-8653AI-B1_J6.2.1_A00_1.0.0_20251103
```

```
{PJ_IF}_{JPV_IF}_A00_{IMGV_IF}_{BD_IF}
```

For example:

```
BOXER-8653AI-B1_J6.2.1_A00_1.0.0_20251103
```

Note: Filename may differ from this example.

{PJ_IF} is Project Information; e.g. BOXER-8653AI-B1

{IMGV_IF} is Build Version; e.g. 1.0.0

{JPV_IF} is Jetpack Version; e.g. J6.2.1

{BD_IF} is Build Date; e.g. 20251103

Chapter 4

OS User Guide

4.1 Introduction

The BOXER-8653AI-Plus' OS, Ubuntu/Linux version, and preinstalled SDK components are as follows:

For **Jetpack 6.2.1 (l4t 36.4.4)**

1. Ubuntu/Linux version
 - a. Ubuntu version: 22.04.5
 - b. Kernel version: 5.15.148-tegra
 - c. UEFI version: 36.4.4-gcid-41062509
2. Built-in all Jetson SDK Components
 - a. CUDA Toolkit for L4T 12.6.10
 - b. cuDNN 9.3.0
 - c. TensorRT 10.3.0
 - d. OpenCV 4.8
 - e. VPI 3.2
 - f. NVIDIA Container Runtime 2.1
 - g. Multimedia API 36.4.4
 - h. Nsight Systems 2024.5
 - i. Nsight Graphics 2024.2
 - j. Deepstream 7.1
3. Built-in Allxon DMS
 - a. Pls refer <https://www.allxon.com/solutions>

Default login user/password is:

Account: **aaeon**

Password: **aaeon**

4.2 Update Note

Running `$ sudo apt upgrade` command in terminal will overwrite the **AAEON kernel device tree (.dtb), kernel image (Image)** or bootloader in OS, which can lead to unexpected results including losing I/O ports. Therefore, AAEON disables the NVIDIA apt repository by default to prevent updating NVIDIA packages.

4.3 BOXER-8653AI-PLUS Power Mode

NVIDIA® Jetson Orin™ NX power mode can be selected and monitored via the GUI, please refer to the following picture:

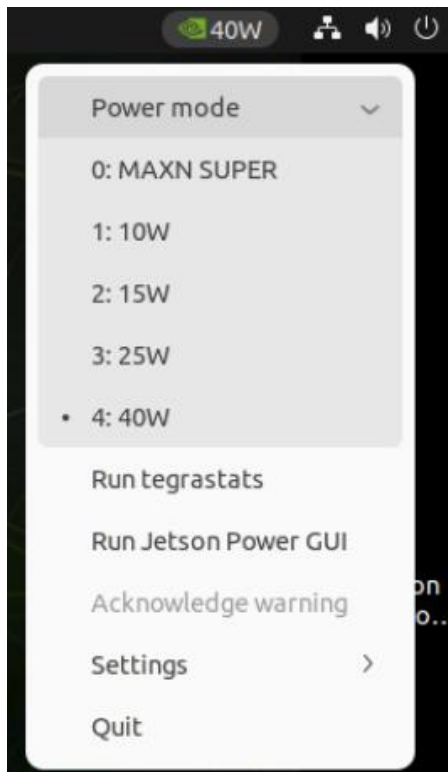

Jetson Power GUI

Main Thermal / Power Monitor

Platform: AAEON BOXER-8653AI-B1 Platform nvpmodel: 40W

CPU			Sensor	
Name	Freq (MHz)	Load %	Name	Temperature (C)
cpu0	1267.2 MHz	3 %	cpu-thermal	54.2 C
cpu1	1267.2 MHz	1 %	cv0-thermal	51.4 C
cpu2	1267.2 MHz	1 %	cv1-thermal	49.7 C
cpu3	1267.2 MHz	0 %	cv2-thermal	48.7 C
cpu4	806.4 MHz	10 %	gpu-thermal	54.0 C
cpu5	806.4 MHz	3 %	soc0-thermal	53.1 C
cpu6	806.4 MHz	8 %	soc1-thermal	52.8 C
cpu7	806.4 MHz	0 %	soc2-thermal	50.2 C
			tj-thermal	54.2 C

GPU			Power Monitor		
Name	Freq (MHz)	Load %	Name	Inst (mW)	Avg (mW)
igpu0	306.0 MHz	0 %	VDD IN	6643 mW	6994 mW
			VDD CPU GPU CV	810 mW	1052 mW
			VDD SOC	1701 mW	1701 mW
					<input type="button" value="reset avg"/>

EMC				Fan	
Name	Freq (MHz) / Size (MB)	Load %	Name	fan1	
emc	204.0 MHz	16 %	Profile	quiet	
memory	1546/15656 MB	10 %	PWM	34.51 %	
swap	0/7828 MB	0 %	RPM	0 rpm	

Engine				Disk	
Name	Freq (MHz)	Name	Freq (MHz)	Size	
dla0	offline	nvjpg1	offline	21455/124292 MB	
dla1	offline	se	offline		
pva	offline	ape	offline		
nvdec	offline				
nvenc	offline				
nvjpg0	offline				

Record hr min sec background

Note: Power mode is dependent on DRAM size. For more detailed information please visit:

<https://docs.nvidia.com/jetson/archives/r36.4.4/DeveloperGuide/SD/PlatformPowerAndPerformance/JetsonOrinNanoSeriesJetsonOrinNxSeriesAndJetsonAgxOrinSeries.html#supported-modes-and-power-efficiency>

4.4 DIO Command Setting for BOXER-8653AI-PLUS

Please refer to the Hardware DIO/GPIO section for pin number and GPIO ID mapping.

Take "pin 6 <-> GPIO ID: PZ.03" as an example on JetPack 6.2.1:

```
# Print gpio information
$ sudo gpioinfo
```

```
# Read gpio level, e.g PZ.03
$ sudo gpioget $(sudo gpiofind PZ.03)
```

```
# Set gpio level, e.g. PZ.03, high
$ sudo gpioset --mode=wait $(sudo gpiofind PZ.03)=1
# Set gpio level, e.g. PZ.03, low
$ sudo gpioset --mode=wait $(sudo gpiofind PZ.03)=0
```