

BOXER-8332AI

Embedded AI Vision System

User's Manual 2nd Ed

Copyright Notice

This document is copyrighted, 2022. All rights are reserved. The original manufacturer reserves the right to make improvements to the products described in this manual at any time without notice.

No part of this manual may be reproduced, copied, translated, or transmitted in any form or by any means without the prior written permission of the original manufacturer. Information provided in this manual is intended to be accurate and reliable. However, the original manufacturer assumes no responsibility for its use, or for any infringements upon the rights of third parties that may result from its use.

The material in this document is for product information only and is subject to change without notice. While reasonable efforts have been made in the preparation of this document to assure its accuracy, AAEON assumes no liabilities resulting from errors or omissions in this document, or from the use of the information contained herein. AAEON reserves the right to make changes in the product design without notice to its users.

Acknowledgement

- Microsoft Windows® is a registered trademark of Microsoft Corp.
- Intel®, Pentium®, Celeron®, and Xeon® are registered trademarks of Intel Corporation
- Intel Core™ is a trademark of Intel Corporation
- NVIDIA® is a registered trademark of NVIDIA Corporation

All other product names or trademarks are properties of their respective owners. The publisher of this document does not assume nor imply ownership of any trademarked product not listed herein.

Packing List

Before setting up your product, please make sure the following items have been shipped:

Item	Quantity
● BOXER-8332AI-CFL	1
● NVIDIA® A2	1
● Wallmount Bracket	2
● 3-Pin DC-In Power Connector	1
● Screw Package	1
● Thermal Pad Package	1

If any of these items are missing or damaged, please contact your distributor or sales representative immediately.

About this Document

This User's Manual contains all the essential information, such as detailed descriptions and explanations on the product's hardware and software features (if any), its specifications, dimensions, jumper/connector settings/definitions, and driver installation instructions (if any), to facilitate users in setting up their product.

Users may refer to the product page at AAEON.com for the latest version of this document.

Safety Precautions

Please read the following safety instructions carefully. It is advised that you keep this manual for future references

1. All cautions and warnings on the device should be noted.
2. Make sure the power source matches the power rating of the device.
3. Position the power cord so that people cannot step on it. Do not place anything over the power cord.
4. Always completely disconnect the power before working on the system's hardware.
5. No connections should be made when the system is powered as a sudden rush of power may damage sensitive electronic components.
6. If the device is not to be used for a long time, disconnect it from the power supply to avoid damage by transient over-voltage.
7. Always disconnect this device from any power supply before cleaning.
8. While cleaning, use a damp cloth instead of liquid or spray detergents.
9. Make sure the device is installed near a power outlet and is easily accessible.
10. Keep this device away from humidity.
11. Place the device on a solid surface during installation to prevent falls.
12. Do not cover the openings on the device to ensure optimal heat dissipation.
13. Watch out for high temperatures when the system is running.
14. Do not touch the heat sink or heat spreader when the system is running
15. Never pour any liquid into the openings. This could cause fire or electric shock.
16. As most electronic components are sensitive to static electrical charge, be sure to ground yourself to prevent static charge when installing the internal components. Use a grounding wrist strap and contain all electronic components in any static-shielded containers.

17. If any of the following situations arises, please contact our service personnel:
 - i. Damaged power cord or plug
 - ii. Liquid intrusion to the device
 - iii. Exposure to moisture
 - iv. Device is not working as expected or in a manner as described in this manual
 - v. The device is dropped or damaged
 - vi. Any obvious signs of damage displayed on the device
18. Do not leave this device in an uncontrolled environment with temperatures beyond the device's permitted storage temperatures (see chapter 1) to prevent damage.
19. Do NOT disassemble the motherboard so as not to damage the system or void your warranty.
20. If the thermal pad had been damaged, please contact AAEON's salesperson to purchase a new one. Do NOT use those of other brands.
21. The Hex Cylinder Coppers on the front panel are not removable.
22. Repeatedly assemble and disassemble the system may cause damages to the exterior paint and surface and screw holes.
23. Use the right size screwdriver.
24. Use the screwdriver correctly to remove screws from the system.

FCC Statement

Warning!



This device complies with Part 15 FCC Rules. Operation is subject to the following two conditions: (1) this device may not cause harmful interference, and (2) this device must accept any interference received including interference that may cause undesired operation.

Caution:

There is a danger of explosion if the battery is incorrectly replaced. Replace only with the same or equivalent type recommended by the manufacturer. Dispose of used batteries according to the manufacturer's instructions and your local government's recycling or disposal directives.

Attention:

Il y a un risque d'explosion si la batterie est remplacée de façon incorrecte. Ne la remplacer qu'avec le même modèle ou équivalent recommandé par le constructeur. Recycler les batteries usées en accord avec les instructions du fabricant et les directives gouvernementales de recyclage.

产品中有毒有害物质或元素名称及含量

AAEON System

QO4-381 Rev.A0

部件名称	有毒有害物质或元素					
	铅 (Pb)	汞 (Hg)	镉 (Cd)	六价铬 (Cr(VI))	多溴联苯 (PBB)	多溴二苯 醚(PBDE)
印刷电路板 及其电子组件	×	○	○	○	○	○
外部信号 连接器及线材	×	○	○	○	○	○
外壳	○	○	○	○	○	○
中央处理器 与内存	×	○	○	○	○	○
硬盘	×	○	○	○	○	○
液晶模块	×	×	○	○	○	○
光驱	×	○	○	○	○	○
触控模块	×	○	○	○	○	○
电源	×	○	○	○	○	○
电池	×	○	○	○	○	○

本表格依据 SJ/T 11364 的规定编制。

○：表示该有毒有害物质在该部件所有均质材料中的含量均在 GB/T 26572 标准规定的限量要求以下。

×：表示该有害物质的某一均质材料超出了 GB/T 26572 的限量要求，然而该部件

仍符合欧盟指令 2011/65/EU 的规范。

备注：

一、此产品所标示之环保使用期限，系指在一般正常使用状况下。

二、上述部件物质中央处理器、内存、硬盘、光驱、电源为选购品。

三、上述部件物质液晶模块、触控模块仅一体机产品适用。

Hazardous and Toxic Materials List

AAEON System

QO4-381 Rev.A0

Component Name	Hazardous or Toxic Materials or Elements					
	Lead (Pb)	Mercury (Hg)	Cadmium (Cd)	Hexavalent Chromium (Cr(VI))	Polybrominated biphenyls (PBBS)	Polybrominated diphenyl ethers (PBDES)
PCB and Components	X	O	O	O	O	O
Wires & Connectors for Ext.Connections	X	O	O	O	O	O
Chassis	O	O	O	O	O	O
CPU & RAM	X	O	O	O	O	O
HDD Drive	X	O	O	O	O	O
LCD Module	X	X	O	O	O	O
Optical Drive	X	O	O	O	O	O
Touch Control Module	X	O	O	O	O	O
PSU	X	O	O	O	O	O
Battery	X	O	O	O	O	O

This form is prepared in compliance with the provisions of SJ/T 11364.

O: The level of toxic or hazardous materials present in this component and its parts is below the limit specified by GB/T 26572.

X: The level of toxic of hazardous materials present in the component exceed the limits specified by GB/T 26572, but is still in compliance with EU Directive 2011/65/EU (RoHS 2).

Notes:

1. The Environment Friendly Use Period indicated by labelling on this product is applicable only to use under normal conditions.
2. Individual components including the CPU, RAM/memory, HDD, optical drive, and PSU are optional.
3. LCD Module and Touch Control Module only applies to certain products which feature these components.

Table of Contents

Chapter 1 - Product Specifications	1
1.1 Specifications.....	2
Chapter 2 – Hardware Information	5
2.1 Dimensions	6
2.2 Jumpers and Connectors	9
2.3 List of Jumpers	10
2.3.1 PCIe [x16] Bifurcation Selection (JP1, JP2)	10
2.3.2 Clear CMOS Jumper (JP3).....	11
2.3.3 PCIe, SATA Selection for M.2 Slot (JP4).....	11
2.3.4 PCIe, SATA Selection for Mini Card Slot (JP5)	11
2.3.5 PCIe [x16] Lanes Normal/Reversed (JP11)	11
2.3.6 Auto Power Button Selection (JP20)	12
2.4 List of Connectors	13
2.4.1 PCIe [x4] Slot (CN5).....	15
2.4.2 Audio I/O Port (10P Pitch: 1.25mm) (CN7).....	18
2.4.3 Dual HDMI Port (CN8)	18
2.4.4 LAN (RJ-45) + Dual USB 3.0 (CN9).....	19
2.4.5 LAN (RJ-45) + Dual USB 3.0 (CN10)	21
2.4.6 LAN (RJ-45) + Dual USB 3.0 (CN11).....	23
2.4.7 CPU FAN Connector (CN12)	25
2.4.8 System FAN Connector (CN13)	25
2.4.9 M.2 2280 M-Key Connector (CN14)	26
2.4.10 Remote Button Connector (CN16)	29
2.4.11 PS_ON Connector	29
2.4.12 SPI Flash Port (CN18).....	29
2.4.13 LPC Connector (CN19).....	30

2.4.14	SATA Connector (CN20, CN23, CN24, CN26)	31
2.4.15	SATA Power Connector (CN21, CN22, CN25, CN27)	31
2.4.16	Digital IO Port (CN28)	32
2.4.17	COM 1/COM 2 Connector (RS-232/RS-422/RS-485) (CN29)	33
2.4.18	COM Port 1 Wafer Box (Optional) (CN30)	34
2.4.19	COM Port 2 Wafer Box (Optional) (CN31)	35
2.4.20	COM 3/COM 4 Connector (RS-232/RS-422/RS-485) (CN32)	36
2.4.21	COM Port 3 Wafer Box (Optional) (CN33)	37
2.4.22	COM Port 4 Wafer Box (Optional) (CN34)	38
2.4.23	COM Port 5 Wafer Box (Optional) (CN35)	39
2.4.24	COM Port 6 Wafer Box (Optional) (CN36)	40
2.4.25	Mini Card Slot (Full-Sized) (CN37)	41
2.4.26	SIM Slot (CN38)	43
2.4.27	Mini Card Slot (Half-Sized) (CN39)	44
2.4.28	USB 2.0 Wafer Box (CN40, CN41, CN42, CN43)	46
2.4.29	Audio Jack Connector (CN44)	47
2.4.30	Audio Connector Wafer Box	48
2.4.31	DC-IN Connector (CN48)	49
2.4.32	GPU DC-IN Connector (CN50, CN51)	49
2.4.33	RTC Battery Connector (BAT1)	50
2.5	CPU Installation	51
2.6	Expansion Card Installation	52
Chapter 3	- AMI BIOS Setup	55
3.1	System Test and Initialization	56
3.2	AMI BIOS Setup	57
3.3	Setup Submenu: Main	58
3.4	Setup Submenu: Advanced	59
3.4.1	Trusted Computing	60

3.4.2	CPU Configuration	62
3.4.3	PCH-FW Configuration.....	64
3.4.3.1	Firmware Update Configuration.....	65
3.4.3.2	PTT Configuration	66
3.4.4	SATA Configuration	67
3.4.5	USB Configuration.....	68
3.4.6	Hardware Monitor	69
3.4.6.1	Smart Fan Mode Configuration.....	70
3.4.7	SIO Configuration.....	72
3.4.7.1	Serial Port 1 Configuration.....	73
3.4.7.2	Serial Port 2 Configuration	74
3.4.7.3	Serial Port 3 Configuration	75
3.4.7.4	Serial Port 4 Configuration	76
3.4.8	Network Stack Configuration	77
3.4.9	Digital IO Port Configuration	79
3.4.10	Power Management.....	80
3.5	Setup Submenu: Chipset.....	81
3.5.1	System Agent (SA) Configuration	82
3.5.2	PEG Port Configuration	84
3.5.3	PCH-IO Configuration	85
3.6	Setup Submenu: Security	86
3.6.1	Secure Boot.....	87
3.6.1.1	Key Management.....	88
3.7	Setup Submenu: Boot.....	91
3.8	Setup Submenu: Save & Exit	92
Chapter 4 – Drivers Installation		93
4.1	Drivers Download and Installation.....	94
Appendix A - Watchdog Timer Programming.....		96

A.1	Watchdog Timer Introduction	97
A.2	Watchdog Timer Initial Program.....	98
Appendix B - I/O Information.....		103
B.1	I/O Address Map.....	104
B.2	IRQ Mapping Chart	106
B.3	Memory Address Map.....	116
Appendix C - Digital I/O Ports.....		117
C.1	DIO Introduction	118
C.2	Electrical Specifications for Digital I/O Ports	118
C.3	DIO Programming	119
C.4	Digital I/O Register.....	120
C.5	Digital I/O Sample Program.....	121
Appendix D – Glue Removal Procedure.....		127
D.1	Removing Glue from Your System.....	128

Chapter 1

Product Specifications

1.1 Specifications

System

CPU	Intel® Xeon® E-2124G
	Intel® Xeon® E-2278GEL
	Intel® Core™ i7-9700TE
	Intel® Core™ i7-8700T
	Intel® Core™ i5-8500T
	Intel® Core™ i3-8100T
	Pentium® G5400T
	Celeron® G4900T
	Note: Supports Max. TDP 71W
Chipset	Intel® C246 (no H310 Downward Support)
System Memory	DDR4 SODIMM x 4
	Supports Max 2666MHz up to 128GB
	Supports Unbuffered and ECC/non-ECC Type SODIMM
Display Interface	HDMI 1.4 x 2
	Supports Dual Independent 4K Ultra HD Displays
Storage Device	2.5" SATA Drive Bay x 2 (SATA Port w/ RAID Function x 4)
	Half-Size Mini Card x 1 for mSATA (optional)
	M.2 2280 M-Key x 1 (NVMe)
Ethernet	RJ-45 x 3 (GbE LAN):
	Intel® i211AT x 2
	Intel® i219LM x 1

System

I/O	USB 3.2 Gen 1 x 6 Mic-In x 1 Line-Out x 1 DB-9 x 4 (RS-232/422/485) SMA Antenna Holes x 3 Power ON/OFF Switch x 1 Remote Power On/OFF Connector x 1 Reset Switch x 1
Expansion	Full-Size Mini Card x 1 (PCIe + USB with 1 SIM Slot) Half-Size Mini Card x 1 (PCIe + USB, mSATA Optional) M.2 2280 M-Key x 1 (PCIe [x4]) PCIe [x4] x 1
Reserved Connector	Internal: SATA x 2 8-Bit DIO x 1 USB 2.0 x 4 LPC x 1 Secondary System Fan Connector x 1
Indicator	System Power LED (Green) Storage Activity LED (Red)
OS Support	Windows® 10 64-bit Ubuntu 20.04.3/Kernel 5.40.-72

Power Supply

Power Requirement	3-pin Terminal Block, DC-In 12~24V
--------------------------	------------------------------------

Mechanical

Mounting	Wallmount
Dimensions (W x H x D)	8.66" x 5.91" x 11.02" (220mm x 150mm x 280mm)
Gross Weight	17.6 lb. (8 Kg)
Net Weight	15.4 lb. (7 Kg)

Environmental

Operating Temperature	32°F ~ 104°F (0°C ~ 40°C) IEC68-2 with 0.5 m/s airflow
Storage Temperature	-49°F ~ 176°F (-45°C ~ 80°C)
Storage Humidity	5~95% at 40°C, Non-Condensing
Anti-Vibration	1Grms/ 5 ~ 500Hz/ Operation with SSD
Shock	5G at Wallmount, Half-Sine, 11ms with SSD
Certification	CE/FCC Class A

Chapter 2

Hardware Information

2.1 Dimensions

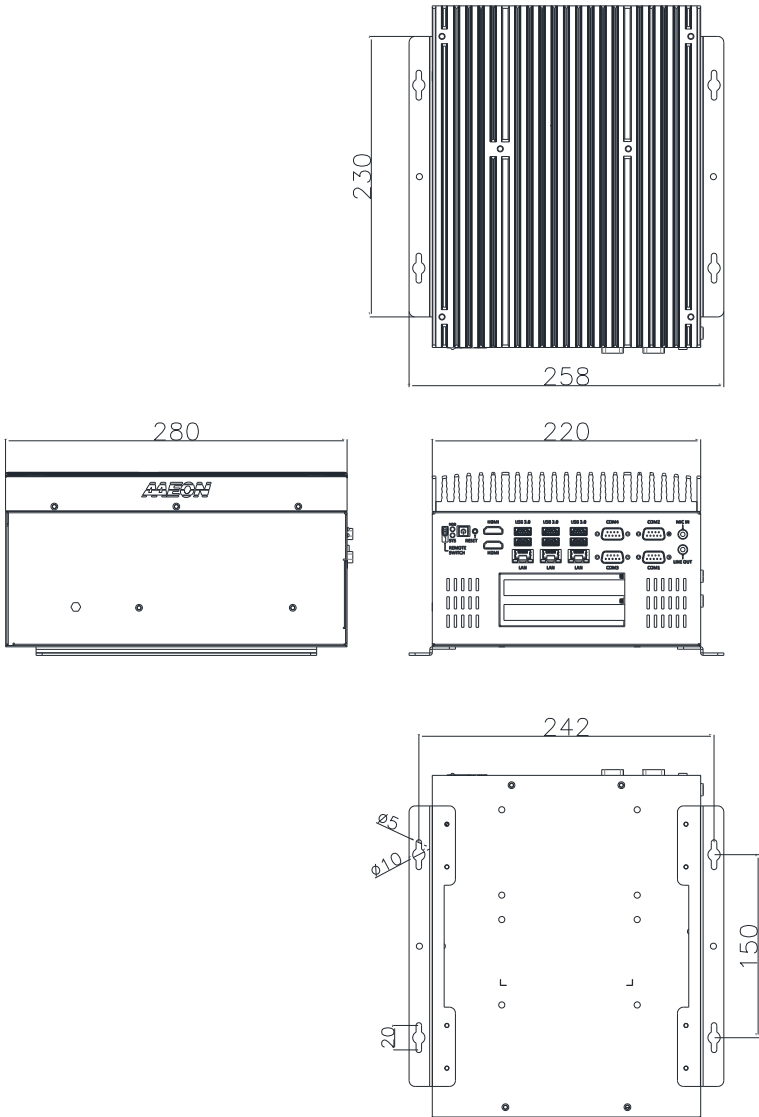

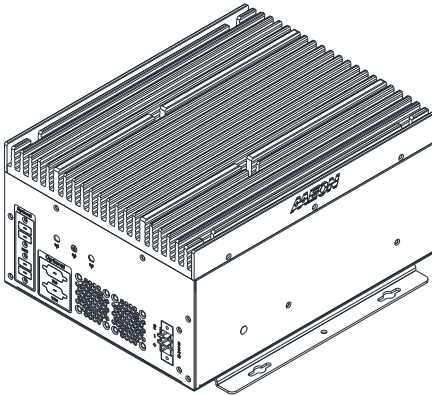
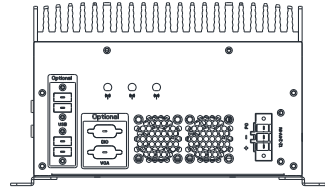
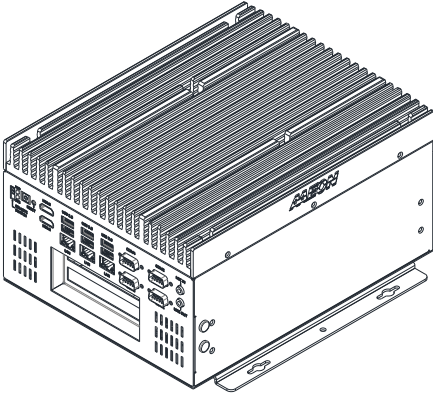

Main Board

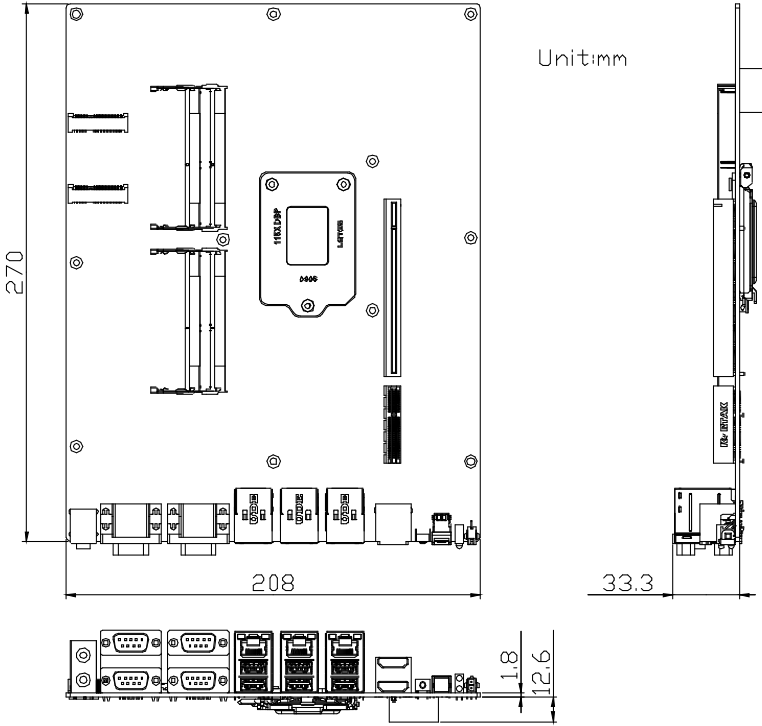

2.2 Jumpers and Connectors

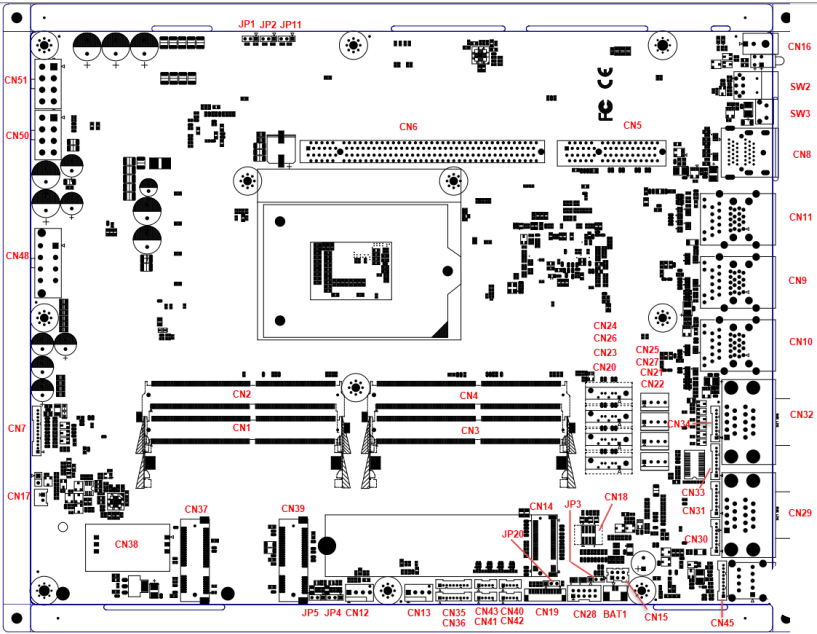

2.3 List of Jumpers

Please refer to the table below for all of the system's jumpers that you can configure for your application.

Label	Function
JP1, JP2	PCIe [x16] Bifurcation Selection
JP3	CMOS Control Selection
JP4	PCIe and SATA Bus Selection for M.2 Slot
JP5	PCIe and SATA Bus Selection for Mini Card Slot
JP11	PCIe [x16] Lane Normal/Reversed Selection
JP20	Auto-Power Button Selection

2.3.1 PCIe [x16] Bifurcation Selection (JP1, JP2)

To set bifurcation selection, you must set jumpers on both JP1 and JP2 according to this chart.

Setting	JP1	JP2
PCIe [x16] x 1 (Default)	<div style="display: flex; justify-content: space-around; margin-bottom: 5px;"> 123 </div>	<div style="display: flex; justify-content: space-around; margin-bottom: 5px;"> 123 </div>
PCIe [x8] x 2	<div style="display: flex; justify-content: space-around; margin-bottom: 5px;"> 123 </div>	<div style="display: flex; justify-content: space-around; margin-bottom: 5px;"> 123 </div>
PCIe [x8] x 1 and PCIe [x4] x 2	<div style="display: flex; justify-content: space-around; margin-bottom: 5px;"> 123 </div>	<div style="display: flex; justify-content: space-around; margin-bottom: 5px;"> 123 </div>
Reserved	<div style="display: flex; justify-content: space-around; margin-bottom: 5px;"> 123 </div>	<div style="display: flex; justify-content: space-around; margin-bottom: 5px;"> 123 </div>

2.3.2 Clear CMOS Jumper (JP3)

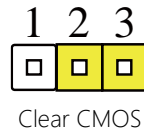
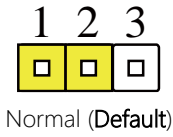

2.3.3 PCIe, SATA Selection for M.2 Slot (JP4)

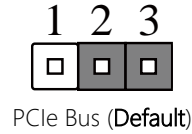
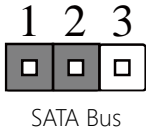

2.3.4 PCIe, SATA Selection for Mini Card Slot (JP5)

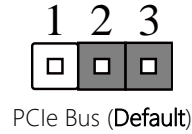
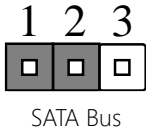

2.3.5 PCIe [x16] Lanes Normal/Reversed (JP11)

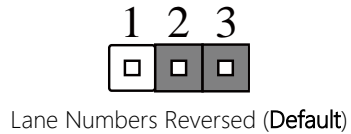
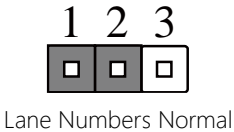

2.3.6 Auto Power Button Selection (JP20)

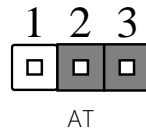
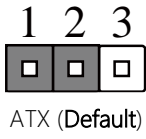

2.4 List of Connectors

Please refer to the table below for all of the system's connectors that you can configure for your application.

Label	Function
CN1	SO-DIMM Channel A0
CN2	SO-DIMM Channel A1
CN3	SO-DIMM Channel B0
CN4	SO-DIMM Channel B1
CN5	PCIe [x4] Slot
CN6	PCIe [x16] Slot
CN7	VGA Box Connector
CN8	Dual HDMI Port
CN9	LAN (RJ-45) + Dual USB 3.0 Connector
CN10	LAN (RJ-45) + Dual USB 3.0 Connector
CN11	LAN (RJ-45) + Dual USB 3.0 Connector
CN12	CPU FAN Connector
CN13	System FAN Connector
CN14	M.2 2280 M-Key Connector
CN15	PS/2 Connector
CN16	Remote Button Connector
CN17	PS_ON Connector
CN18	SPI ROM Connector
CN19	LPC Bus Connector
CN20	SATA Connector
CN21	SATA PWR Connector
CN22	SATA PWR Connector
CN23	SATA Connector
CN24	SATA Connector
CN25	SATA PWR Connector
CN26	SATA Connector
CN27	SATA PWR Connector
CN28	DIO Box Connector

Label	Function
CN29	COM 1/COM 2 Connector RS-232/RS-422/RS-485
CN30	COM 1 Header RS-232/RS-422/RS-485
CN31	COM 2 Header RS-232/RS-422/RS-485
CN32	COM 3/COM 4 Connector RS-232/RS-422/RS-485
CN33	COM 3 Header RS-232/RS-422/RS-485
CN34	COM 4 Header RS-232/RS-422/RS-485
CN35	COM 5 Header RS-232/RS-422/RS-485
CN36	COM 6 Header RS-232/RS-422/RS-485
CN37	Mini PCIe Slot (Full Size)
CN38	SIM Card Slot
CN39	Mini PCIe Slot (Half Size)
CN40	USB 2.0 Box Connector
CN41	USB 2.0 Box Connector
CN42	USB 2.0 Box Connector
CN43	USB 2.0 Box Connector
CN44	Audio Connector
CN45	Audio Box Connector
CN48	Power Input Connector for System
CN50	Power Input Connector for GPU
CN51	Power Input Connector for GPU
SW2	Power Button with LED
SW3	Release Button
BAT1	RTC Battery Connector

2.4.1 PCIe [x4] Slot (CN5)

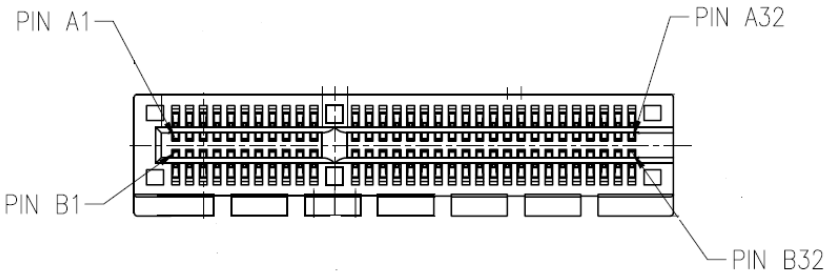

Pin	Pin Name	Signal Type	Signal Level
A1	PRSNT1#	I/O	
A2	+12V	PWR	+V12S
A3	+12V	PWR	+V12S
A4	GND	GND	
A5	PCIE_TXN5	DIFF	
A6	PCIE_TXP5	DIFF	
A7	PCIE_RXN5	DIFF	
A8	PCIE_RXP5	DIFF	
A9	+3.3V	PWR	+V3.3S
A10	+3.3V	PWR	+V3.3S
A11	PERST#	I/O	
A12	GND	GND	
A13	PCIE_x4SLOT_CLK	DIFF	
A14	PCIE_x4SLOT_CLK#	DIFF	
A15	GND	GND	
A16	PCIE_RXP24	DIFF	
A17	PCIE_RXN24	DIFF	

Pin	Pin Name	Signal Type	Signal Level
A18	GND	GND	
A19	NC		
A20	GND	GND	
A21	PCIE_RXP23	DIFF	
A22	PCIE_RXN23	DIFF	
A23	GND	GND	
A24	GND	GND	
A25	PCIE_RXP22	DIFF	
A26	PCIE_RXP22	DIFF	
A27	GND	GND	
A28	GND	GND	
A29	PCIE_RXP21	DIFF	
A30	PCIE_RXN21	DIFF	
A31	GND	GND	
A32	NC		
B1	+12V	PWR	+V12S
B2	+12V	PWR	+V12S
B3	+12V	PWR	+V12S
B4	GND	GND	
B5	SMB_CLK	I/O	
B6	SMB_DATA	I/O	
B7	GND	GND	
B8	+V3.3S	PWR	+V3.3S
B9	NC		
B10	3.3Vaux	PWR	+V3.3A
B11	WAKE#	I/O	
B12	NC		

Pin	Pin Name	Signal Type	Signal Level
B13	GND	GND	
B14	PCIE_TXP24	DIFF	
B15	PCIE_TXN24	DIFF	
B16	GND	GND	
B17	PRSNT	I/O	
B18	GND	GND	
B19	PCIE_TXP23	DIFF	
B20	PCIE_TXN23	DIFF	
B21	GND	GND	
B22	GND	GND	
B23	PCIE_TXP22	DIFF	
B24	PCIE_TXN22	DIFF	
B25	GND	GND	
B26	GND	GND	
B27	PCIE_TXP21	DIFF	
B28	PCIE_TXN21	DIFF	
B29	GND	GND	
B30	NC		
B31	PRSNT	I/O	
B32	GND	GND	

2.4.2 Audio I/O Port (10P Pitch: 1.25mm) (CN7)

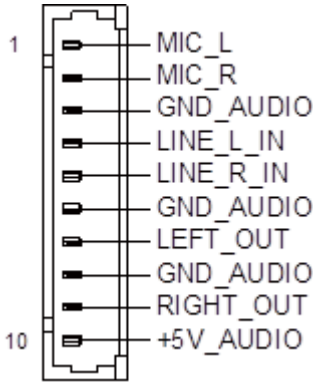

Pin	Pin Name	Signal Type	Signal Level
1	MIC_L	IN	
2	MIC_R	IN	
3	GND_AUDIO	GND	
4	LINE_L_IN	IN	
5	LINE_R_IN	IN	
6	GND_AUDIO	GND	
7	LEFT_OUT	OUT	
8	GND_AUDIO	GND	
9	RIGHT_OUT	OUT	
10	+5V_AUDIO	PWR	+5V

2.4.3 Dual HDMI Port (CN8)

Standard Specifications

2.4.4 LAN (RJ-45) + Dual USB 3.0 (CN9)

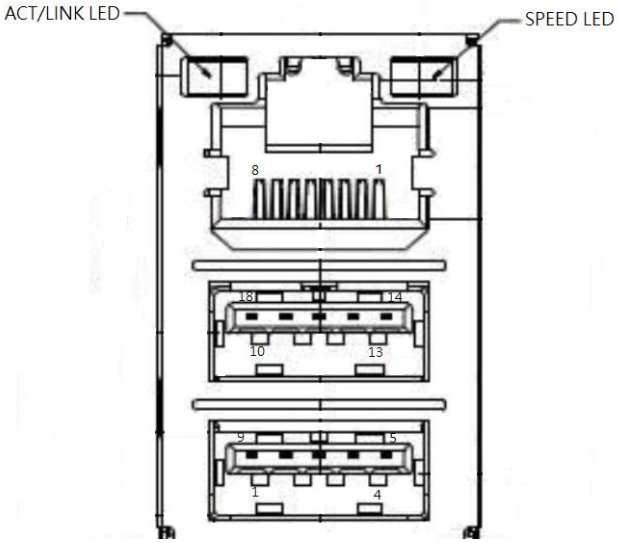

LAN (RJ-45)

Pin	Pin Name	Signal Type	Signal Level
1	MDI0+	DIFF	
2	MDI0-	DIFF	
3	MDI1+	DIFF	
4	MDI2+	DIFF	
5	MDI2-	DIFF	
6	MDI1-	DIFF	
7	MDI3+	DIFF	
8	MDI3-	DIFF	

Dual USB 3.0 (USB 3.2 Gen 2)			
Pin	Pin Name	Signal Type	Signal Level
1	+5VSB	PWR	+5V
2	USB1_D-	DIFF	
3	USB1_D+	DIFF	
4	GND	GND	
5	USB1_SSRX-	DIFF	
6	USB1_SSRX+	DIFF	
7	GND	GND	
8	USB1_SSTX-	DIFF	
9	USB1_SSTX+	DIFF	
10	+5VSB	PWR	+5V
11	USB2_D-	DIFF	
12	USB2_D+	DIFF	
13	GND	GND	
14	USB2_SSRX-	DIFF	
15	USB2_SSRX+	DIFF	
16	GND	GND	
17	USB2_SSTX-	DIFF	
18	USB2_SSTX+	DIFF	

Note: Dual USB 3.0 ports are USB 3.2 Gen 2 (10 Gbps) specification.

2.4.5 LAN (RJ-45) + Dual USB 3.0 (CN10)

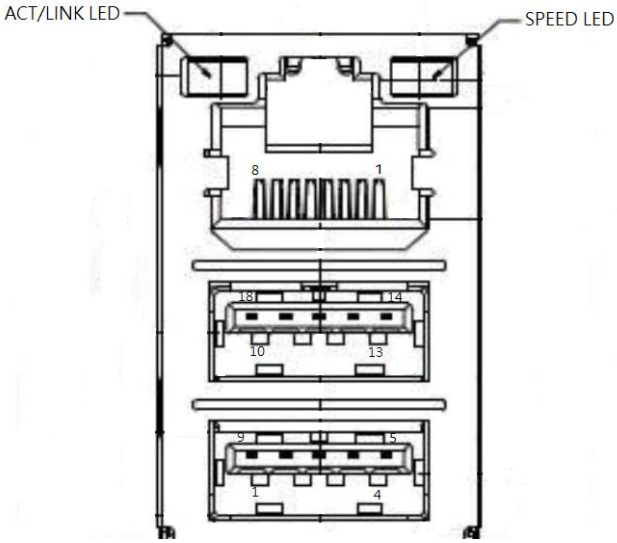

LAN (RJ-45)

Pin	Pin Name	Signal Type	Signal Level
1	MDI0+	DIFF	
2	MDI0-	DIFF	
3	MDI1+	DIFF	
4	MDI2+	DIFF	
5	MDI2-	DIFF	
6	MDI1-	DIFF	
7	MDI3+	DIFF	
8	MDI3-	DIFF	

Dual USB 3.0 (USB 3.2 Gen 2)			
Pin	Pin Name	Signal Type	Signal Level
1	+5VSB	PWR	+5V
2	USB3_D-	DIFF	
3	USB3_D+	DIFF	
4	GND	GND	
5	USB3_SSRX-	DIFF	
6	USB3_SSRX+	DIFF	
7	GND	GNDA	
8	USB3_SSTX-	DIFF	
9	USB3_SSTX+	DIFF	
10	+5VSB	PWR	+5V
11	USB4_D-	DIFF	
12	USB4_D+	DIFF	
13	GND	GND	
14	USB4_SSRX-	DIFF	
15	USB4_SSRX+	DIFF	
16	GND	GND	
17	USB4_SSTX-	DIFF	
18	USB4_SSTX+	DIFF	

Note: Dual USB 3.0 ports are USB 3.2 Gen 2 (10 Gbps) specification.

2.4.6 LAN (RJ-45) + Dual USB 3.0 (CN11)

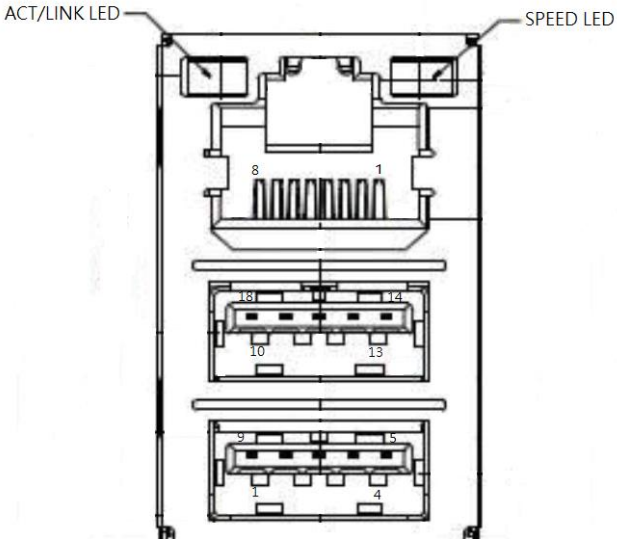

LAN (RJ-45)

Pin	Pin Name	Signal Type	Signal Level
1	MDI0+	DIFF	
2	MDI0-	DIFF	
3	MDI1+	DIFF	
4	MDI2+	DIFF	
5	MDI2-	DIFF	
6	MDI1-	DIFF	
7	MDI3+	DIFF	
8	MDI3-	DIFF	

Dual USB 3.0 (USB 3.2 Gen 2)			
Pin	Pin Name	Signal Type	Signal Level
1	+5VSB	PWR	+5V
2	USB5_D-	DIFF	
3	USB5_D+	DIFF	
4	GND	GND	
5	USB5_SSRX-	DIFF	
6	USB5_SSRX+	DIFF	
7	GND	GND	
8	USB5_SSTX-	DIFF	
9	USB5_SSTX+	DIFF	
10	+5VSB	PWR	+5V
11	USB6_D-	DIFF	
12	USB6_D+	DIFF	
13	GND	GND	
14	USB6_SSRX-	DIFF	
15	USB6_SSRX+	DIFF	
16	GND	GND	
17	USB6_SSTX-	DIFF	
18	USB6_SSTX+	DIFF	

Note: Dual USB 3.0 ports are USB 3.2 Gen 2 (10 Gbps) specification.

2.4.7 CPU FAN Connector (CN12)

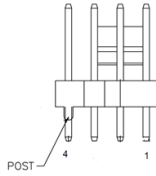

Pin	Pin Name	Signal Type	Signal Level
1	GND	GND	
2	+VCC_FAN_CPU_CON	PWR	12V
3	FAN_TAC_CPU_CON	IN	
4	FAN_CTL_CPU_CON	OUT	

2.4.8 System FAN Connector (CN13)

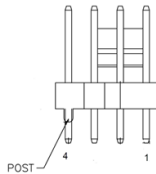

Pin	Pin Name	Signal Type	Signal Level
1	GND	GND	
2	+VCC_FAN_CPU_CON	PWR	12V
3	FANIN2	IN	
4	FANCTL2	OUT	

2.4.9 M.2 2280 M-Key Connector (CN14)

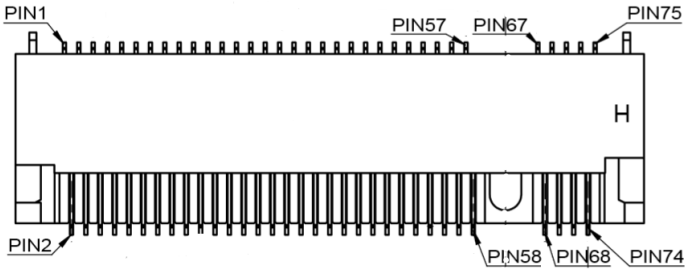

Pin	Pin Name	Signal Type	Signal Level
Top (Odd)			
1	GND	GND	
3	GND	GND	
5	PCIE_RXN16	IN	
7	PCIE_RXP16	IN	
9	GND	GND	
11	PCIE_TXN16	OUT	
13	PCIE_TXP16	OUT	
15	GND	PWR	
17	PCIE_RXN15	IN	
19	PCIE_RXP15	IN	
21	GND	PWR	
23	PCIE_TXN15	OUT	
25	PCIE_TXP15	OUT	
27	GND	PWR	
29	PCIE_RXN14	IN	
31	PCIE_RXP14	IN	
33	GND	GND	

Pin	Pin Name	Signal Type	Signal Level
35	PCIE_TXN14	OUT	
37	PCIE_TXP14	OUT	
39	GND	GND	
41	PCIE_RXP13/SATA0A_R	IN	
43	PCIE_RXN13/SATA0A_R	IN	
45	GND	GND	
47	PCIE_TXN13/SATA0A_T	OUT	
49	PCIE_TXP13/SATA0A_TX	OUT	
51	GND	PWR	
53	PCIE_M.2_CLK#	OUT	
55	PCIE_M.2_CLK	OUT	
57	GND	GND	
67	NC		
69	M.2_SATA_PCIE_DET_C	OUT	
71	GND	GND	
73	GND	GND	
75	GND	GND	
Bottom Even			
2	+3.3V	PWR	+3.3V
4	+3.3V	PWR	+3.3V
6	NC		
8	NC		
10	NC		
12	+3.3V	PWR	+3.3V
14	+3.3V	PWR	+3.3V
16	+3.3V	PWR	+3.3V

Pin	Pin Name	Signal Type	Signal Level
18	+3.3V	PWR	+3.3V
20	NC		
22	NC		
24	NC		
26	NC		
28	NC		
30	NC		
32	NC		
34	NC		
36	NC		
38	DEVSLP	IN	
40	NC		
42	NC		
44	NC		
46	NC		
48	NC		
50	RESET#	IN	
52	CLKREQ#	OUT	
54	WAKE#	OUT	
56	NC		
58	NC		
68	NC		
70	+3.3V	PWR	+3.3V
72	+3.3V	PWR	+3.3V
74	+3.3V	PWR	+3.3V

2.4.10 Remote Button Connector (CN16)

Pin	Pin Name	Signal Type	Signal Level
1	PWR_BUTTON	IN	
3	GND	GND	

2.4.11 PS_ON Connector

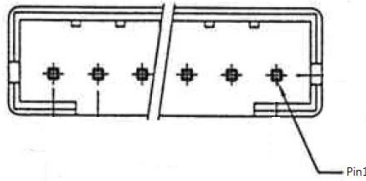

Pin	Pin Name	Signal Type	Signal Level
1	PS_ON	OUT	
2	GND	GND	

2.4.12 SPI Flash Port (CN18)

Pin	Pin Name	Signal Type	Signal Level
1	SPI_MISO	OUT	
2	GND	GND	
3	SPI_CLK	IN	
4	+3.3VSB	PWR	+3.3V
5	SPI_MOSI	IN	
6	SPI_CS	IN	
7	NC		
8	NC		

2.4.13 LPC Connector (CN19)

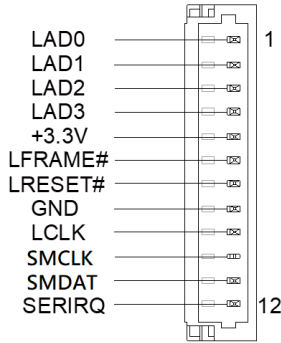

Pin	Pin Name	Signal Type	Signal Level
1	LAD0	I/O	+3.3V
2	LAD1	I/O	+3.3V
3	LAD2	I/O	+3.3V
4	LAD3	I/O	+3.3V
5	+3.3V	PWR	+3.3V
6	LFRAME#	IN	
7	LRESET#	OUT	+3.3V
8	GND	GND	
9	LCLK	OUT	
10	SMCLK	IN	
11	SMDAT	IN	
12	SERIRQ	I/O	+3.3V

2.4.14 SATA Connector (CN20, CN23, CN24, CN26)

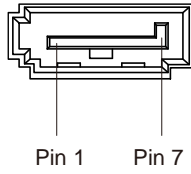

Pin	Pin Name	Signal Type	Signal Level
1	GND	GND	
2	SATA_TX+	DIFF	
3	SATA_TX-	DIFF	
4	GND	GND	
5	SATA_RX-	DIFF	
6	SATA_RX+	DIFF	
7	GND	GND	

2.4.15 SATA Power Connector (CN21, CN22, CN25, CN27)

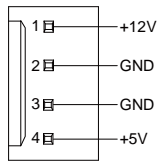

Pin	Pin Name	Signal Type	Signal Level
1	+12V	PWR	+12V
2	GND	GND	
3	GND	GND	
4	+5V	PWR	+5V

2.4.16 Digital IO Port (CN28)

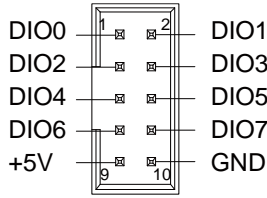

Pin	Pin Name	Signal Type	Signal Level
1	DIO0	I/O	+5V
2	DIO1	I/O	+5V
3	DIO2	I/O	+5V
4	DIO3	I/O	+5V
5	DIO4	I/O	+5V
6	DIO5	I/O	+5V
7	DIO6	I/O	+5V
8	DIO7	I/O	+5V
9	+5V	PWR	+5V
10	GND	GND	

2.4.17 COM 1/COM 2 Connector (RS-232/RS-422/RS-485) (CN29)

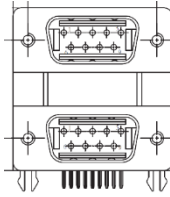

Pin	Pin Name	Signal Type	RS-422	RS-485
1	DCD1	IN	RS422_TX-	RS485_D-
2	RX1	IN	RS422_TX+	RS485_D+
3	TX1	OUT	RS422_RX+	
4	DTR1	OUT	RS422_RX-	
5	GND	GND		
6	DSR1	IN		
7	RTS1	OUT		
8	CTS1	IN		
9	RI1	IN		
10	DCD2	IN	RS422_TX-	RS485_D-
11	RX2	IN	RS422_TX+	RS485_D-
12	TX2	OUT	RS422_RX+	
13	DTR2	OUT	RS422_RX-	
14	GND	GND		
15	DSR2	IN		
16	RTS2	OUT		
17	CTS2	IN		
18	RI2	IN		

2.4.18 COM Port 1 Wafer Box (Optional) (CN30)

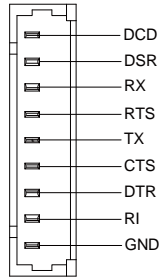

Pin	Pin Name	Signal Type	RS-422	RS-485
1	DCD1	IN	RS422_TX-	RS485_D-
2	DSR1	IN		
3	RX1	IN	RS422_TX+	RS485_D+
4	RTS1	OUT		
5	TX1	OUT	RS422_RX+	
6	CTS1	IN		
7	DTR1	OUT	RS422_RX-	
8	RI1	IN		
9	GND	GND		

2.4.19 COM Port 2 Wafer Box (Optional) (CN31)

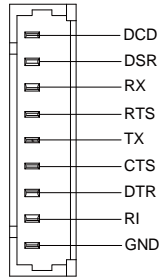

Pin	Pin Name	Signal Type	RS-422	RS-485
1	DCD2	IN	RS422_TX-	RS485_D-
2	DSR2	IN		
3	RX2	IN	RS422_TX+	RS485_D+
4	RTS2	OUT		
5	TX2	OUT	RS422_RX+	
6	CTS2	IN		
7	DTR2	OUT	RS422_RX-	
8	RI2	IN		
9	GND	GND		

2.4.20 COM 3/COM 4 Connector (RS-232/RS-422/RS-485) (CN32)

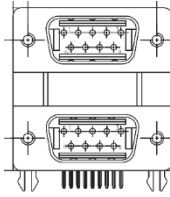

Pin	Pin Name	Signal Type	RS-422	RS-485
1	DCD3	IN	RS422_TX-	RS485_D-
2	RX3	IN	RS422_TX+	RS485_D+
3	TX3	OUT	RS422_RX+	
4	DTR3	OUT	RS422_RX-	
5	GND	GND		
6	DSR3	IN		
7	RTS3	OUT		
8	CTS3	IN		
9	RI3	IN		
10	DCD4	IN	RS422_TX-	RS485_D-
11	RX4	IN	RS422_TX+	RS485_D-
12	TX4	OUT	RS422_RX+	
13	DTR4	OUT	RS422_RX-	
14	GND	GND		
15	DSR4	IN		
16	RTS4	OUT		
17	CTS4	IN		
18	RI4	IN		

2.4.21 COM Port 3 Wafer Box (Optional) (CN33)

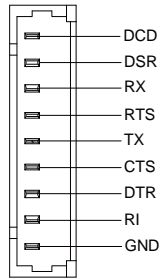

Pin	Pin Name	Signal Type	RS-422	RS-485
1	DCD3	IN	RS422_TX-	RS485_D-
2	DSR3	IN		
3	RX3	IN	RS422_TX+	RS485_D+
4	RTS3	OUT		
5	TX3	OUT	RS422_RX+	
6	CTS3	IN		
7	DTR3	OUT	RS422_RX-	
8	RI3	IN		
9	GND	GND		

2.4.22 COM Port 4 Wafer Box (Optional) (CN34)

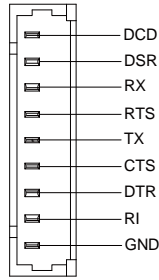

Pin	Pin Name	Signal Type	RS-422	RS-485
1	DCD4	IN	RS422_TX-	RS485_D-
2	DSR4	IN		
3	RX4	IN	RS422_TX+	RS485_D+
4	RTS4	OUT		
5	TX4	OUT	RS422_RX+	
6	CTS4	IN		
7	DTR4	OUT	RS422_RX-	
8	RI4	IN		
9	GND	GND		

2.4.23 COM Port 5 Wafer Box (Optional) (CN35)

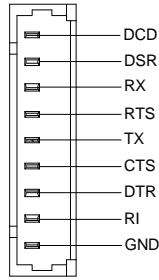

Pin	Pin Name	Signal Type	RS-422	RS-485
1	DCD5	IN	RS422_TX-	RS485_D-
2	DSR5	IN		
3	RX5	IN	RS422_TX+	RS485_D+
4	RTS5	OUT		
5	TX5	OUT	RS422_RX+	
6	CTS5	IN		
7	DTR5	OUT	RS422_RX-	
8	RI5	IN		
9	GND	GND		

2.4.24 COM Port 6 Wafer Box (Optional) (CN36)

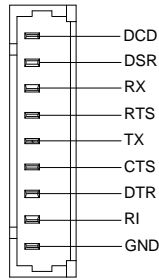

Pin	Pin Name	Signal Type	RS-422	RS-485
1	DCD6	IN	RS422_TX-	RS485_D-
2	DSR6	IN		
3	RX6	IN	RS422_TX+	RS485_D+
4	RTS16	OUT		
5	TX6	OUT	RS422_RX+	
6	CTS6	IN		
7	DTR6	OUT	RS422_RX-	
8	RI6	IN		
9	GND	GND		

2.4.25 Mini Card Slot (Full-Sized) (CN37)

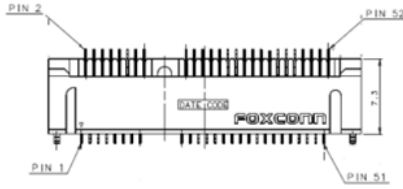

Pin	Pin Name	Signal Type	Signal Level
1	PCIE_WAKE#	IN	
2	+3.3V	PWR	+3.3V
3	NC		
4	GND	GND	
5	NC		
6	+1.5V	PWR	+1.5V
7	PCIE_CLK_REQ#	IN	
8	UIM_PWR	PWR	
9	GND	GND	
10	UIM_DATA	I/O	
11	PCIE_REF_CLK-	DIFF	
12	UIM_CLK	IN	
13	PCIE_REF_CLK+	DIFF	
14	UIM_RESET	IN	
15	GND	GND	
16	UIM_VPP	PWR	
17	NC		
18	GND	GND	
19	NC		
20	W_DISABLE#	OUT	+3.3V

Pin	Pin Name	Signal Type	Signal Level
21	GND	GND	
22	PCIE_RST#	OUT	+3.3V
23	PCIE_RX-	DIFF	
24	+3.3VSB	PWR	+3.3V
25	PCIE_RX+	DIFF	
26	GND	GND	
27	GND	GND	
28	+1.5V	PWR	+1.5V
29	GND	GND	
30	SMB_CLK	I/O	+3.3V
31	PCIE_TX-	DIFF	
32	SMB_DATA	I/O	+3.3V
33	PCIE_TX+	DIFF	
34	GND	GND	
35	GND	GND	
36	USB_D-	DIFF	
37	GND	GND	
38	USB_D+	DIFF	
39	+3.3VSB	PWR	+3.3V
40	GND	GND	
41	+3.3VSB	PWR	+3.3V
42	NC		
43	GND	GND	
44	NC		
45	NC		
46	NC		
47	NC		

Pin	Pin Name	Signal Type	Signal Level
48	+1.5V	PWR	+1.5V
49	NC		
50	GND	GND	
51	NC		
52	+3.3VSB	PWR	+3.3V

2.4.26 SIM Slot (CN38)

Pin	Pin Name	Signal Type	Signal Level
1	UIM_PWR	PWR	
2	UIM_RST	IN	
3	UIM_CLK	IN	
4	GND	GND	
5	UIM_VPP	PWR	
6	UIM_DATA	I/O	

2.4.27 Mini Card Slot (Half-Sized) (CN39)

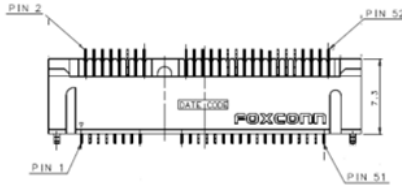

Pin	Pin Name	Signal Type	Signal Level
1	PCIE_WAKE#	IN	
2	+3.3V	PWR	+3.3V
3	NC		
4	GND	GND	
5	NC		
6	+1.5V	PWR	+1.5V
7	PCIE_CLK_REQ#	IN	
8	NC	PWR	
9	GND	GND	
10	NC	I/O	
11	PCIE_REF_CLK-	DIFF	
12	NC	IN	
13	PCIE_REF_CLK+	DIFF	
14	NC	IN	
15	GND	GND	
16	NC	PWR	
17	NC		
18	GND	GND	
19	NC		
20	W_DISABLE#	OUT	+3.3V

Pin	Pin Name	Signal Type	Signal Level
21	GND	GND	
22	PCIE_RST#	OUT	+3.3V
23	PCIE_RX-/SATA_RX+	DIFF	
24	+3.3VSB	PWR	+3.3V
25	PCIE_RX+/SATA_RX-	DIFF	
26	GND	GND	
27	GND	GND	
28	+1.5V	PWR	+1.5V
29	GND	GND	
30	SMB_CLK	I/O	+3.3V
31	PCIE_TX-/SATA_TX-	DIFF	
32	SMB_DATA	I/O	+3.3V
33	PCIE_TX+/SATA_TX+	DIFF	
34	GND	GND	
35	GND	GND	
36	USB_D-	DIFF	
37	GND	GND	
38	USB_D+	DIFF	
39	+3.3VSB	PWR	+3.3V
40	GND	GND	
41	+3.3VSB	PWR	+3.3V
42	NC		
43	GND	GND	
44	NC		
45	MINICARD_SATA_PCIE	IN	
46	NC		
47	NC		

Pin	Pin Name	Signal Type	Signal Level
48	+1.5V	PWR	+1.5V
49	NC		
50	GND	GND	
51	NC		
52	+3.3VSB	PWR	+3.3V

2.4.28 USB 2.0 Wafer Box (CN40, CN41, CN42, CN43)

Pin	Pin Name	Signal Type	Signal Level
1	+5V	GND	+5V
2	USBD-	DIFF	
3	USBD+	DIFF	
4	GND	GND	
5	GND	GND	

Note: USB 2.0 Wafer Box (5P Pitch: 1.25mm)

2.4.29 Audio Jack Connector (CN44)

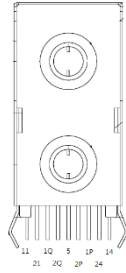

Pin	Pin Name	Signal Type	Signal Level
11	MIC_R		
21	LOUT_R		
1Q	HP_DET2		
5	GND	GND	
2P	HP_DET3		
1P	HP_DET1		
24	LOUT_L		
14	MIC_L		

2.4.30 Audio Connector Wafer Box

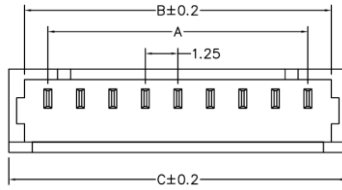

Pin	Pin Name	Signal Type	Signal Level
1	MIC_L		
2	MIC_R		
3	GND	GND	
4	LIN_L		
5	LIN_R		
6	GND	GND	
7	LOUT_L		
8	LOUT_R		
9	GND	GND	
10	VDD_AUD	PWR	5V

2.4.31 DC-IN Connector (CN48)

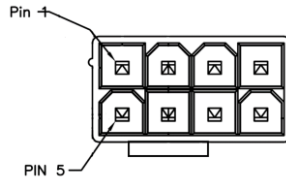

Pin	Pin Name	Signal Type	Signal Level
1	GND	GND	
2	GND	GND	
3	GND	GND	
4	GND	GND	
5	VIN	PWR	
6	VIN	PWR	
7	VIN	PWR	
8	VIN	PWR	

2.4.32 GPU DC-IN Connector (CN50, CN51)

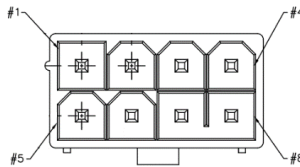

Pin	Pin Name	Signal Type	Signal Level
1	+12V	PWR	+12V
2	+12V	PWR	+12V
3	+12V	PWR	+12V

Pin	Pin Name	Signal Type	Signal Level
4	+12V	PWR	+12V
5	GND	GND	
6	GND	GND	
7	GND	GND	
8	GND	GND	

2.4.33 RTC Battery Connector (BAT1)

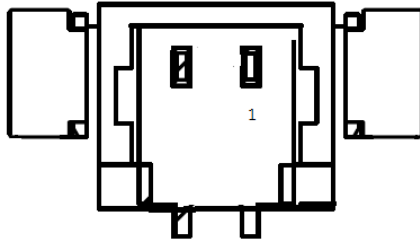

Pin	Pin Name	Signal Type	Signal Level
1	+3.3VA_RTC	PWR	3.3V
2	GND	GND	

2.5 CPU Installation

Step 1: Power down the system, unplug the power cord and ensure the system is off.

Step 2: Have 8th Generation Intel Core, Xeon, Celeron or Pentium CPU ready. See Chapter 1 for processor compatibility.

Step 3: Remove the top cover by unscrewing the four retention screws. You will see the CPU socket as in Figure 1.

Step 4: Install the CPU. Ensure you have also placed the thermal pad(s) as shown in figure 2.

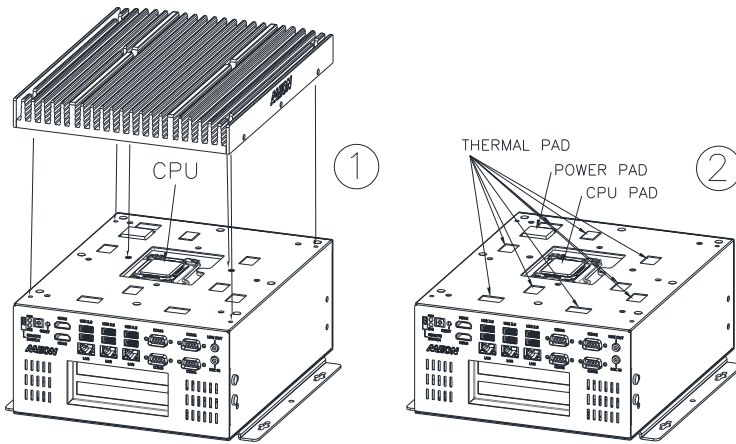

Step 5: Replace the top cover and secure with the four screws removed in Step 3.

2.6 Expansion Card Installation

Step 1: Power down the system, unplug the power cord and ensure the system is off.

Step 2: Have the PCI Express card you wish to install ready, with the rear bracket attached.

Step 3: Remove the bottom panel from the system. Note: there are ten (10) retaining screws. Set the screws in a safe place while working on the system. Remove the two side cover screws (see figure 2)

Step 4: Insert the PCI Express card into the PCI Express slot, pressing in until secure. Secure the rear bracket with two screws (see figure 1).

Step 5: Attach the two side cover screws (see figure 2).

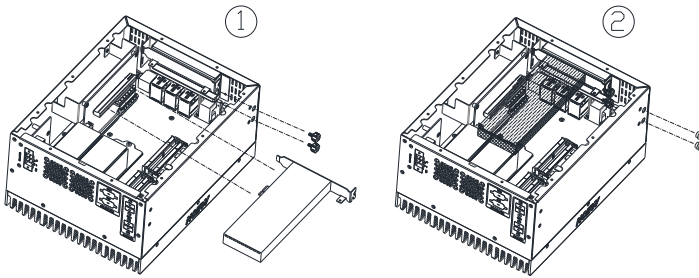

Step 6: Secure the card in place with the sliding bracket as follows:

A: Turn the securing screws counter-clockwise to Open.

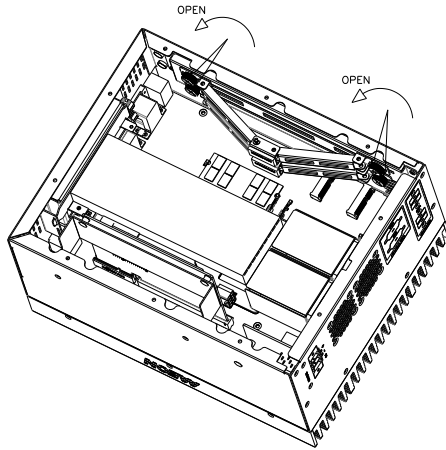

B: Push the middle of the securing bracket down towards the expansion card. Note: the bracket should fit securely but not apply pressure onto the card.

C: Lock the securing screws by turning them clockwise.

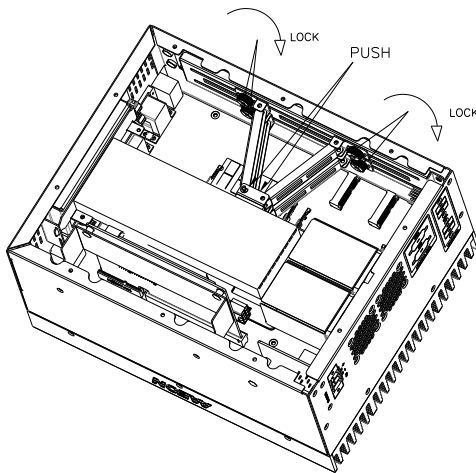

Step 7: Reattach the bottom panel with the ten screws removed in Step 3, as shown in figure 3.

Step 8: Attach mounting brackets as shown in figure 4.

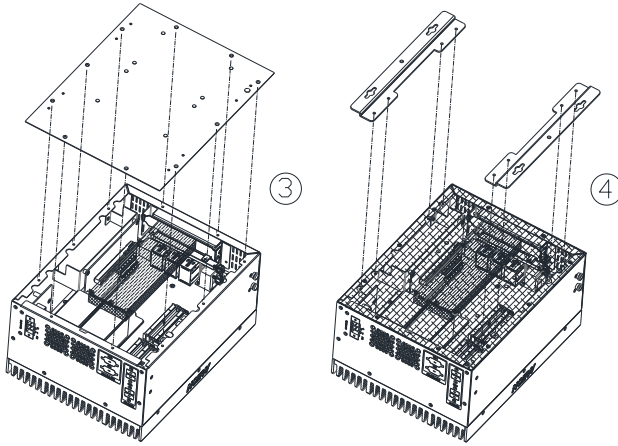

Chapter 3

AMI BIOS Setup

3.1 System Test and Initialization

The system uses certain routines to perform testing and initialization during the boot up sequence. If an error, fatal or non-fatal, is encountered, the system will output a few short beeps or an error message. The board can usually continue the boot up sequence with non-fatal errors.

The system configuration verification routines check the current system configuration against the values stored in the CMOS memory. If they do not match, an error message will be output, and the BIOS setup program will need to be run to set the configuration information in memory.

There are three situations in which the CMOS settings will need to be set or changed:

- Starting the system for the first time
- The system hardware has been changed
- The CMOS memory has lost power and the configuration information is erased

The system's CMOS memory uses a backup battery for data retention. The battery must be replaced when it runs down.

3.2 AMI BIOS Setup

The AMI BIOS ROM has a pre-installed Setup program that allows users to modify basic system configurations, which is stored in the battery-backed CMOS RAM and BIOS NVRAM so that the information is retained when the power is turned off.

To enter BIOS Setup, press or <F2> immediately while your computer is powering up.

The function for each interface can be found below.

Main – Date and time can be set here. Press <Tab> to switch between date elements

Advanced – Access advanced hardware settings and options

Chipset – Chipset settings and options

Security – Set admin and user passwords, access Secure Boot options

Boot – Boot options including BBS priority and Quiet Boot options

Save & Exit – Save changes and exit the program

3.3 Setup Submenu: Main

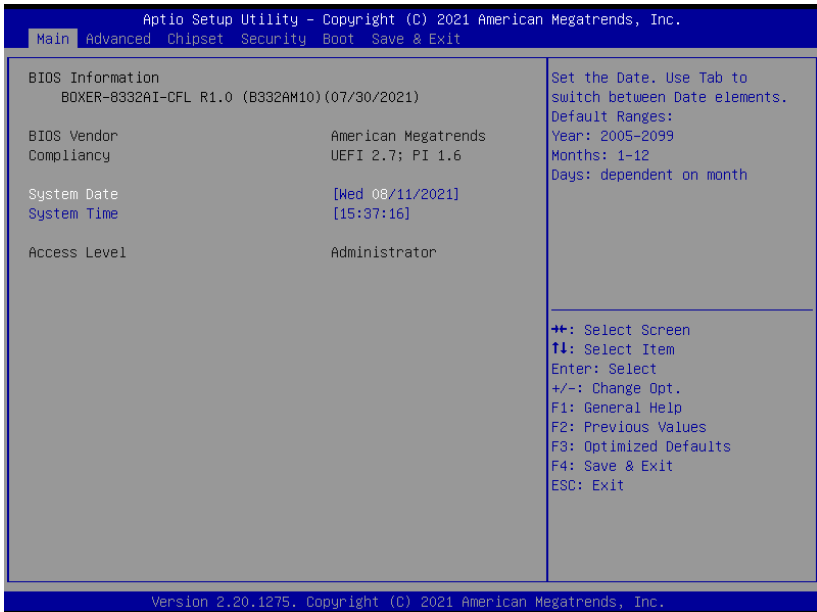

3.4 Setup Submenu: Advanced

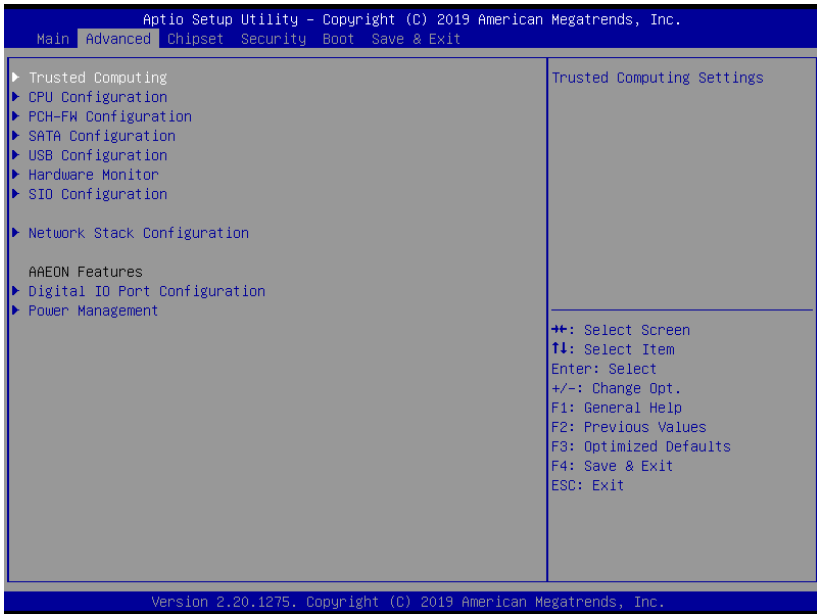

3.4.1 Trusted Computing

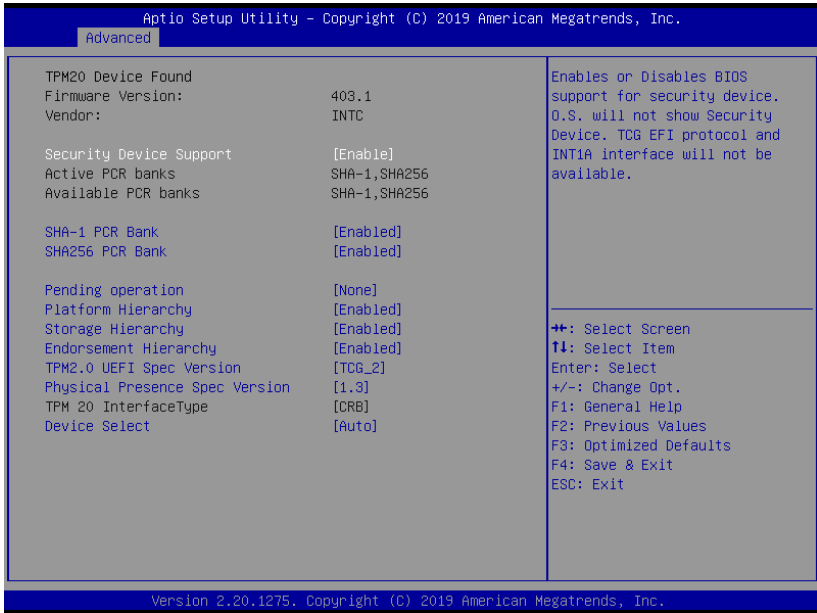

Options Summary		
Security Device Support	Enable	Optimal Default, Failsafe Default
	Disable	
Enable or Disable BIOS support for security device. TCG EFI protocol and INT1A interface will not be available.		
SHA-1 PCR Bank	Enabled	Optimal Default, Failsafe Default
	Disabled	
Enable or Disable SHA-1 PCR Bank		
SHA256 PCR Bank	Enabled	Optimal Default, Failsafe Default
	Disabled	
Enable or Disable SHA256 PCR Bank		
Pending operation	None	Optimal Default, Failsafe Default
	TPM Clear	
Schedule an Operation for the Security Device. NOTE: Your Computer will reboot during restart in order to change State of Security Device.		
Platform Hierarchy	Enabled	Optimal Default, Failsafe Default
	Disabled	

Options Summary		
Enable or Disable Platform Hierarchy		
Storage Hierarchy	Enabled	Optimal Default, Failsafe Default
	Disabled	
Enable or Disable Storage Hierarchy		
Endorsement Hierarchy	Enabled	Optimal Default, Failsafe Default
	Disabled	
Enable or Disable Endorsement Hierarchy		
TPM2.0 UEFI Spec Version	TCG_2	Optimal Default, Failsafe Default
	TCG_1_2	
Select the TCG2 Spec Version Support TCG_1_2: Compatible mode for Win8/Win10 TCG_2: Support new TCG2 protocol and event format for Win10 or later		
Physical Presence Spec Version	1.3	Optimal Default, Failsafe Default
	1.2	
Select to Tell O.S. to support PPI Spec Version 1.2 or 1.3. Note some HCK tests might not support 1.3.		
Device Select	Auto	Optimal Default, Failsafe Default
	TPM 1.2	
	TPM 2.0	
TPM 1.2 will restrict support to TPM 1.2 devices, TPM 2.0 will restrict support to TPM 2.0 devices, Auto will support both with the default set to TPM 2.0 devices if not found, TPM 1.2 devices will be enumerated		

3.4.2 CPU Configuration

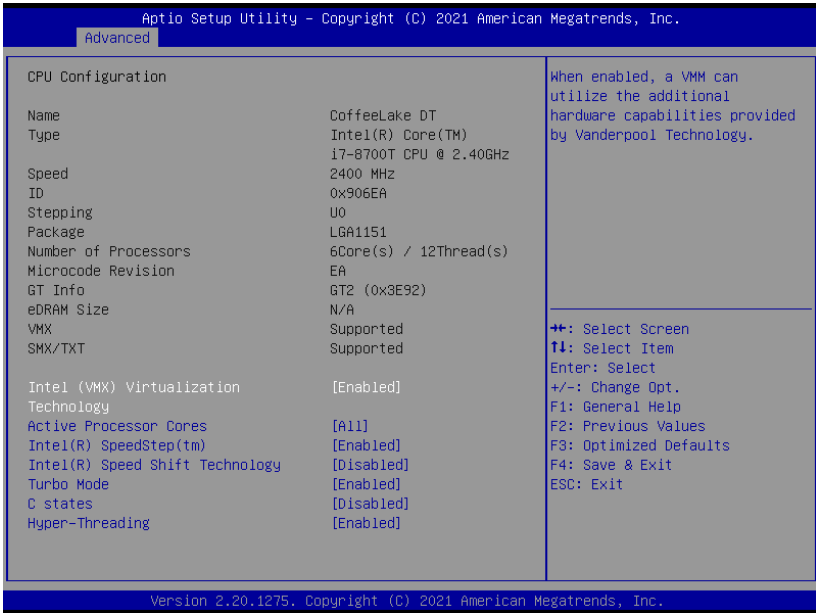

Options Summary		
Intel (VMX) Virtualization Technology	Disabled	
	Enabled	Optimal Default, Failsafe Default
When enabled, a VMM can utilize the additional hardware capabilities provided by Vanderpool Technology.		
Active Processor Cores	1	
	2	
	3	
	All	Optimal Default, Failsafe Default
Number of cores to enable in each processor package.		
Intel(R) SpeedStep(tm)	Disabled	
	Enabled	Optimal Default, Failsafe Default
Allows more than two frequency ranges to be supported.		
Intel(R) Speed Shift Technology	Disabled	Optimal Default, Failsafe Default
	Enabled	

Options Summary		
Enable/Disable Intel(R) Speed Shift Technology support. Enabling will expose the CPPC v2 interface to allow for hardware-controlled P-states.		
Turbo Mode	Disabled	
	Enabled	Optimal Default, Failsafe Default
Enable/Disable Processor Turbo Mode (requires Intel Speed Step or Intel Speed Shift to be available or enabled).		
C states	Disabled	Optimal Default, Failsafe Default
	Enabled	
Enable/Disable CPU Power Management. Allows CPU to go C states when it's not 100% utilized		

3.4.3 PCH-FW Configuration

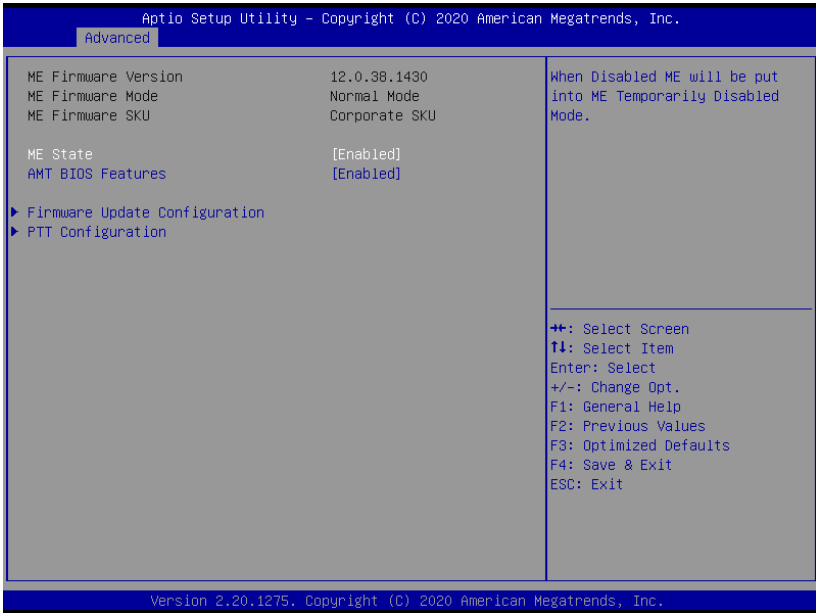

Options Summary		
ME State	Enabled	Optimal Default, Failsafe Default
	Disabled	
When Disabled ME will be put into ME Temporarily Disabled Mode.		
AMT BIOS Feature	Enabled	Optimal Default, Failsafe Default
	Disabled	
When disabled AMT BIOS Features are no longer supported and user is no longer able to access MEBx Setup.		
Note: This option does not disable Manageability Features in FW.		

3.4.3.1 Firmware Update Configuration

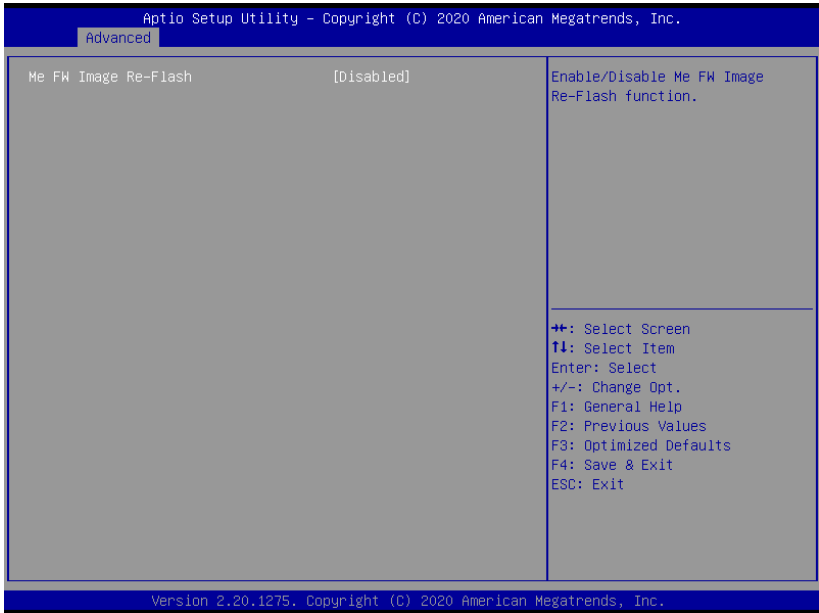

Options Summary		
ME FW Image Re-Flash	Enabled	
	Disabled	Optimal Default, Failsafe Default
Enable/Disable ME FW Image Re-Flash function.		

3.4.3.2 PTT Configuration

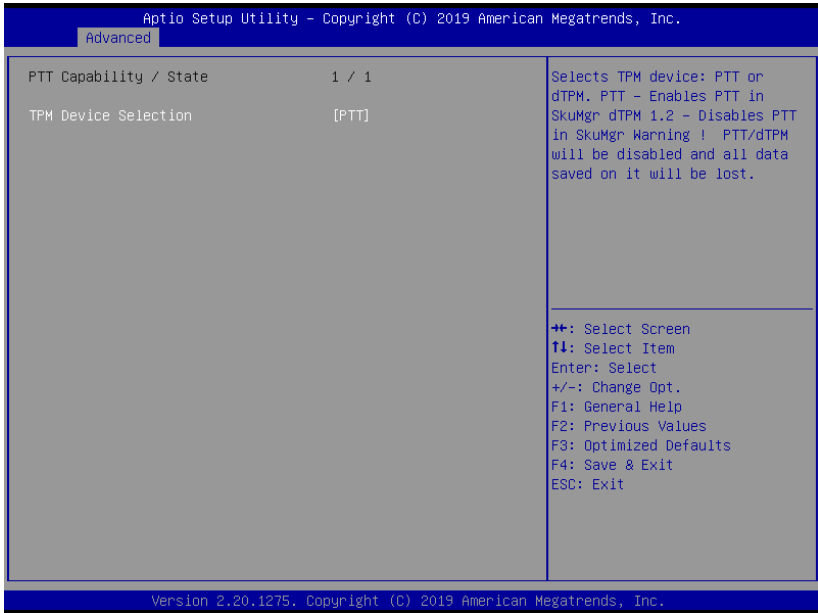

Options Summary		
ME FW Image	dTPM	
Re-Flash	PTT	Optimal Default, Failsafe Default
Selects TPM device: PTT or dTPM. PTT – Enables PTT in SkuMgr dTPM 1.2 – Disables PTT in SkuMgr Warning! PTT/dTPM will be disabled and all saved data will be lost.		

3.4.4 SATA Configuration

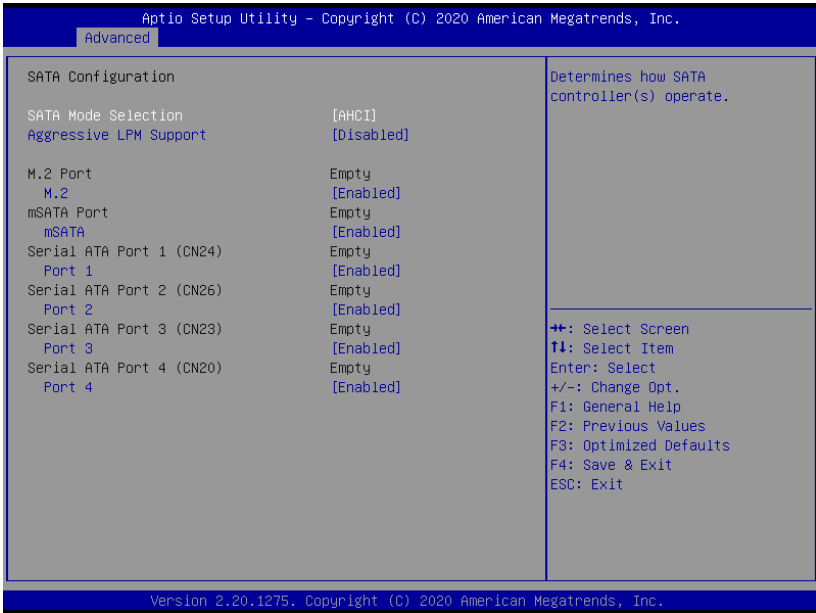

Options Summary		
SATA Mode Selection	AHCI Mode	Optimal Default, Failsafe Default
	Intel RST Premium with Intel Optane System Acceleration	
Determines how SATA controller(s) operate.		
Aggressive LPM Support	Enabled	
	Disabled	Optimal Default, Failsafe Default
Enable PCH to aggressively enter link power state.		
M.2/ mSATA Port	Enabled	Optimal Default, Failsafe Default
	Disabled	
Enable or Disable SATA Port.		
Serial Port 1/2/3/4	Enabled	Optimal Default, Failsafe Default
	Disabled	
Enable or Disable SATA Port.		

3.4.5 USB Configuration

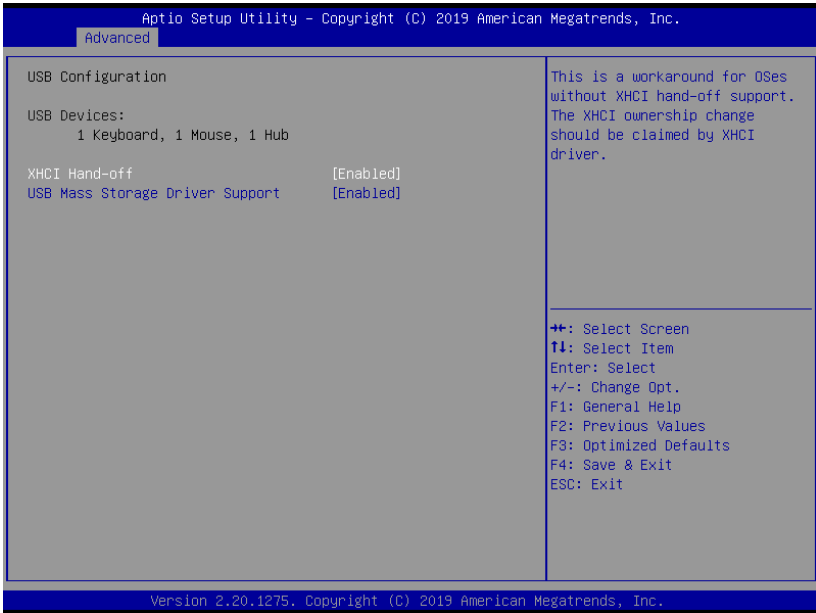

Options Summary		
XHCI Hand-off	Enabled	Optimal Default, Failsafe Default
	Disabled	
This is a workaround for OSes without XHCI Hand-off support. The XHCI ownership change should be claimed by XHCI driver.		
USB Mass Storage Driver Support	Enabled	Optimal Default, Failsafe Default
	Disabled	
Enable/Disable USB Mass Storage Driver Support.		

3.4.6 Hardware Monitor

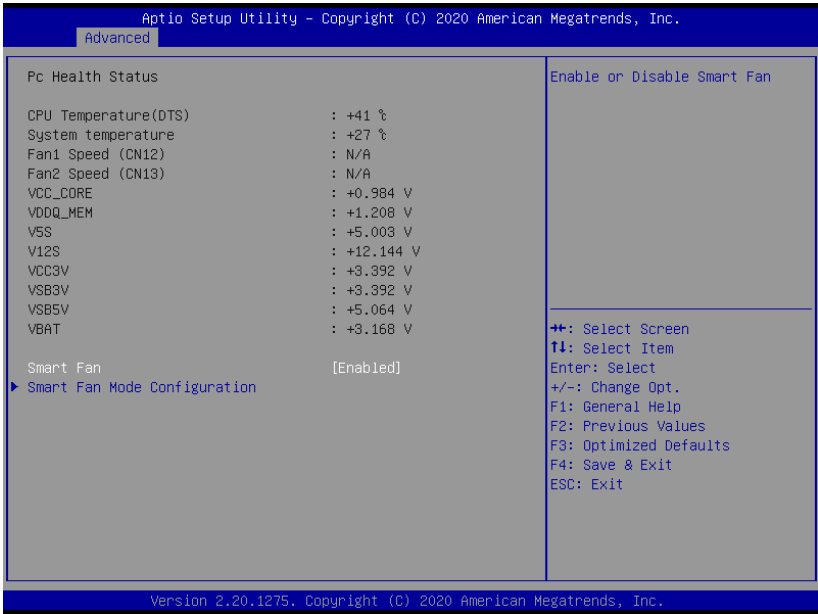

Options Summary		
Smart Fan	Enabled	Optimal Default, Failsafe Default
	Disabled	
Enable or Disable Smart Fan		

3.4.6.1 Smart Fan Mode Configuration

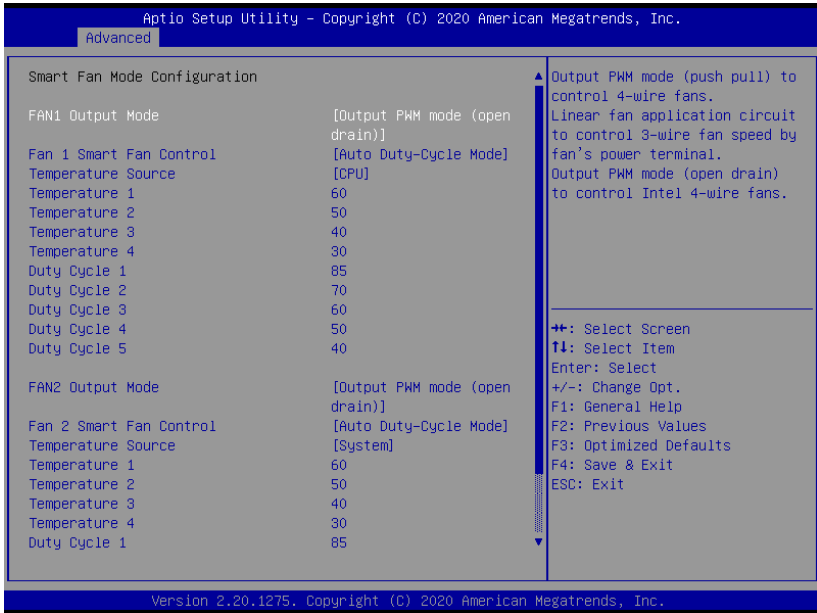

Options Summary		
Fan 1/2 Output Mode	Output PWM mode (push pull)	Optimal Default, Failsafe Default
	Linear Fan Application	
	Output PWM mode (open drain)	
Output PWM mode (push pull) to control 4-wire fans. Linear fan application circuit to control 3-wire fan speed by fan's power terminal. Output PWM mode (open drain) to control Intel 4-wire fans.		
Fan 1 Smart Fan Control	Manual RPM Mode	
	Manual Duty Mode	
	Auto RPM Mode	
	Auto Duty-Cycle Mode	Optimal Default, Failsafe Default
Smart Fan Mode Select		
Temperature Source	CPU	
	System	Optimal Default, Failsafe Default
Select the monitored temperature source for this fan		
Temperature 1/2/3/4	1-100	Range
	60/50/40/30	Optimal Default, Failsafe Default

Options Summary		
Auto fan speed control. Fan speed will follow different temperature by different duty cycle 1-100		
Duty Cycle 1/2/3/4/5	1-100	Range
	85/70/60/50/40	Optimal Default, Failsafe Default
Auto fan speed control. Fan speed will follow different temperature by different duty cycle 1-100		
Fan 2 Smart Fan Control	Manual RPM Mode	
	Manual Duty Mode	
	Auto RPM Mode	
	Auto Duty-Cycle Mode	Optimal Default, Failsafe Default
Smart Fan Mode Select		
Temperature Source	CPU	
	System	Optimal Default, Failsafe Default
Select the monitored temperature source for this fan		
Temperature 1/2/3/4	1-100	Range
	60/50/40/30	Optimal Default, Failsafe Default
Auto fan speed control. Fan speed will follow different temperature by different duty cycle 1-100		
Duty Cycle 1/2/3/4/5	1-100	Range
	85/70/60/50/40	Optimal Default, Failsafe Default
Auto fan speed control. Fan speed will follow different temperature by different duty cycle 1-100		

3.4.7 SIO Configuration

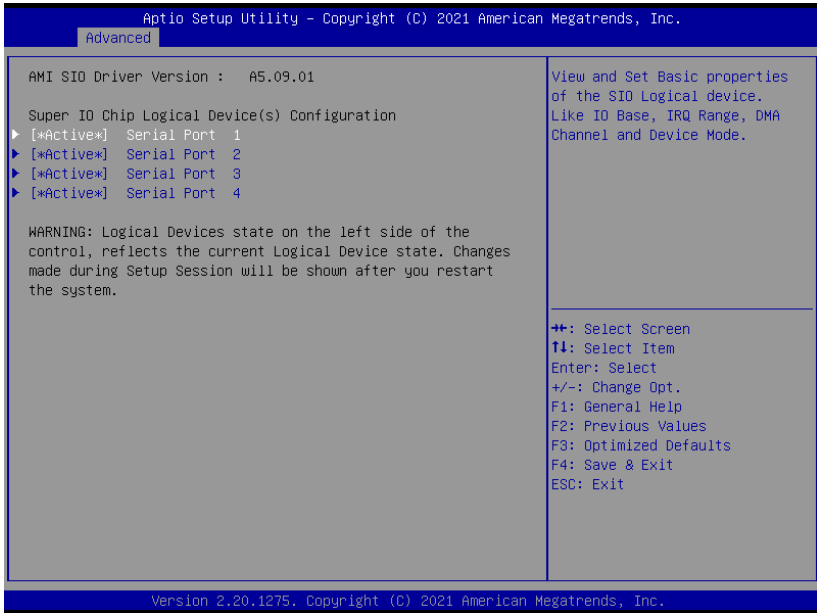

3.4.7.1 Serial Port 1 Configuration

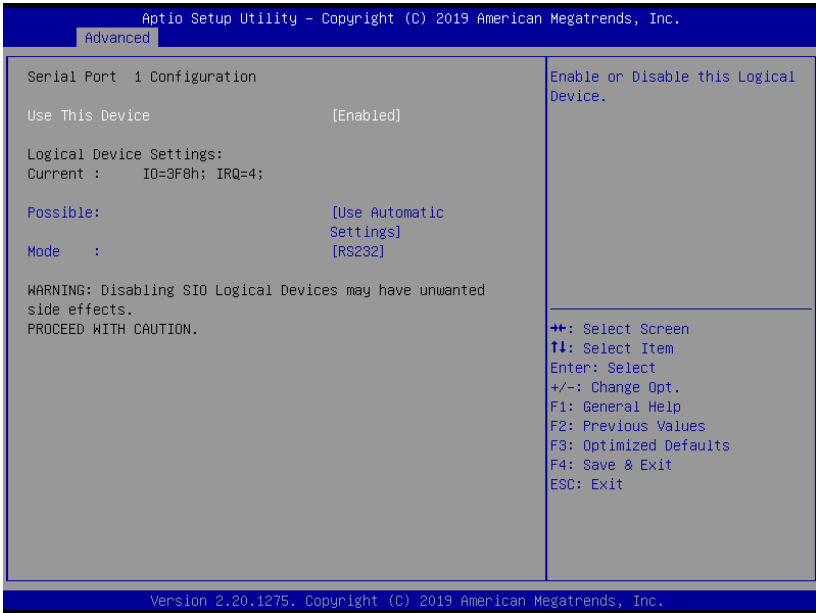

Options Summary		
Use This Device	Enabled	Optimal Default, Failsafe Default
	Disabled	
Enabled or Disabled this Logical Device.		
Device resource settings	USB Automatic Setting	Optimal Default, Failsafe Default
	IO=3F8h; IRQ = 4;	
	IO=2F8h; IRQ = 3;	
Allows the user to change the device resource settings. New settings will be reflected on this setup page after system restarts.		
UART selection	RS232	Optimal Default, Failsafe Default
	RS422	
	RS485	
UART RS232, 422, 485 selection.		

3.4.7.2 Serial Port 2 Configuration

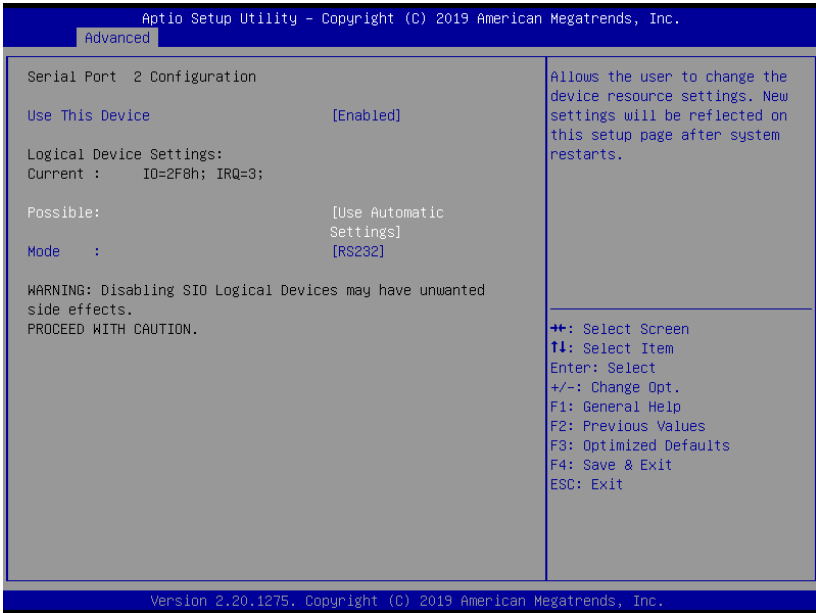

Options Summary		
Use This Device	Enabled	Optimal Default, Failsafe Default
	Disabled	
Enabled or Disabled this Logical Device.		
Device resource settings	USB Automatic Setting	Optimal Default, Failsafe Default
	IO=2F8h; IRQ = 3;	
	IO=3F8h; IRQ = 4;	
Allows the user to change the device resource settings. New settings will be reflected on this setup page after system restarts.		
UART selection	RS232	Optimal Default, Failsafe Default
	RS422	
	RS485	
UART RS232, 422, 485 selection.		

3.4.7.3 Serial Port 3 Configuration

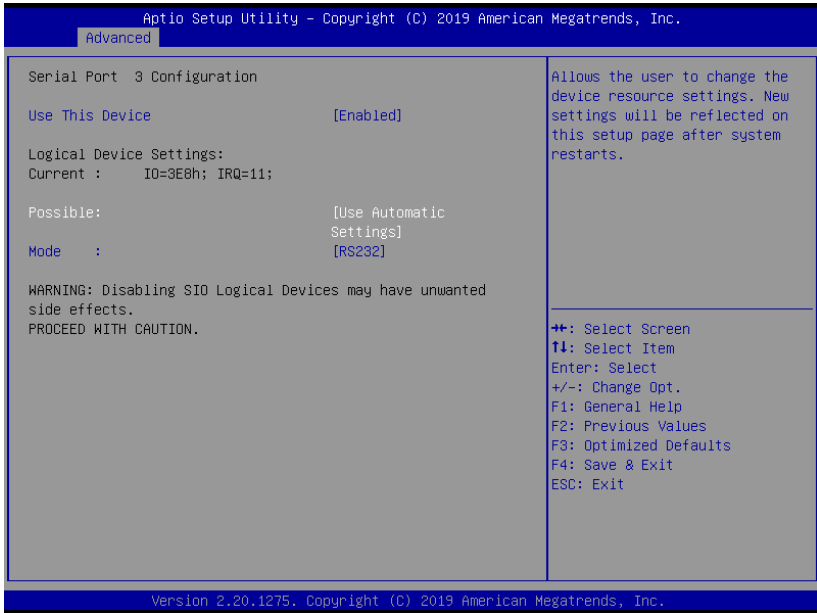

Options Summary		
Use This Device	Enabled	Optimal Default, Failsafe Default
	Disabled	
Enabled or Disabled this Logical Device.		
Device resource settings	USB Automatic Setting	Optimal Default, Failsafe Default
	IO=3E8h; IRQ = 11;	
	IO=2E8h; IRQ = 11;	
Allows the user to change the device resource settings. New settings will be reflected on this setup page after system restarts.		
UART selection	RS232	Optimal Default, Failsafe Default
	RS422	
	RS485	
UART RS232, 422, 485 selection.		

3.4.7.4 Serial Port 4 Configuration

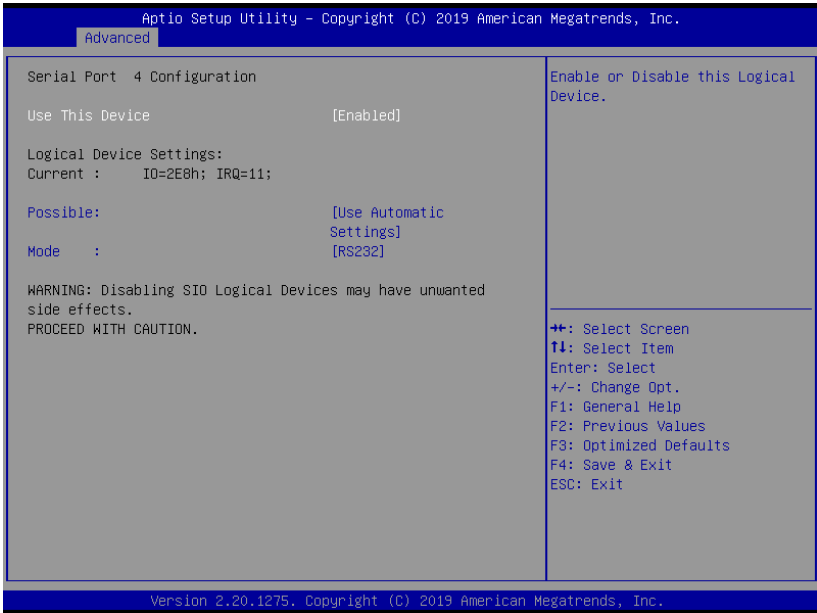

Options Summary		
Use This Device	Enabled	Optimal Default, Failsafe Default
	Disabled	
Enabled or Disabled this Logical Device.		
Device resource settings	USB Automatic Setting	Optimal Default, Failsafe Default
	IO=2E8h; IRQ = 11;	
	IO=3E8h; IRQ = 11;	
Allows the user to change the device resource settings. New settings will be reflected on this setup page after system restarts.		
UART selection	RS232	Optimal Default, Failsafe Default
	RS422	
	RS485	
UART RS232, 422, 485 selection.		

3.4.8 Network Stack Configuration

Network Stack Disabled:

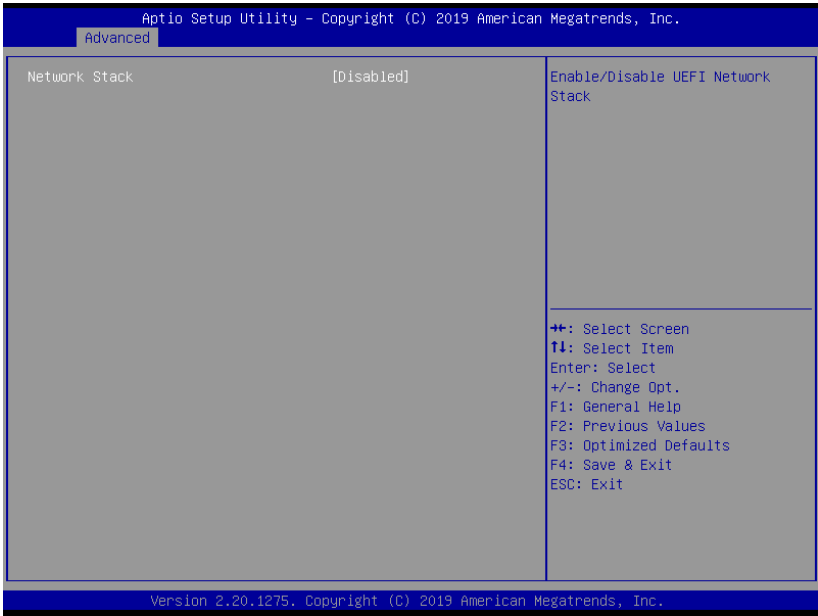

Options Summary		
Network Stack	Disabled	
	Enabled	Optimal Default, Failsafe Default
Enable/Disable UEFI Network Stack		

Network Stack Enabled:

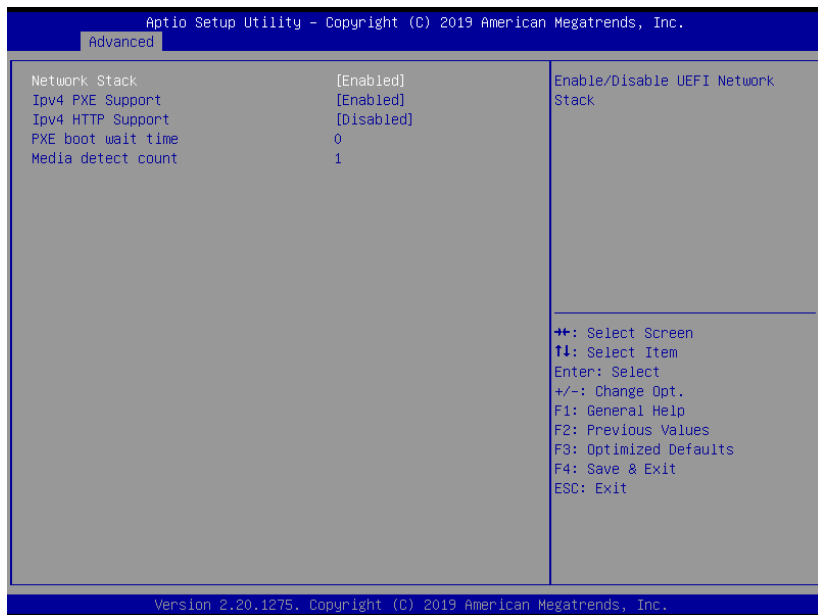

Options Summary		
Network Stack	Disabled	
	Enabled	Optimal Default, Failsafe Default
Enable/Disable UEFI Network Stack		
Ipv4 PXE Support	Disabled	
	Enabled	Optimal Default, Failsafe Default
Enable/Disable IPv4 PXE boot support. If disabled, IPv4 PXE boot support will not be available.		
Ipv4 HTTP Support	Disabled	Optimal Default, Failsafe Default
	Enabled	
Enable/Disable IPv4 HTTP boot support. If disabled, IPv4 HTTP boot support will not be available.		
PXE boot wait time	0	Optimal Default, Failsafe Default
Wait time in seconds to press ESC key to abort the PXE boot. Use either +/- or numeric keys to set the value.		
Media detect count	1	Optimal Default, Failsafe Default
Number of times the presence of media will be checked. Use either +/- or numeric keys to set the value.		

3.4.9 Digital IO Port Configuration

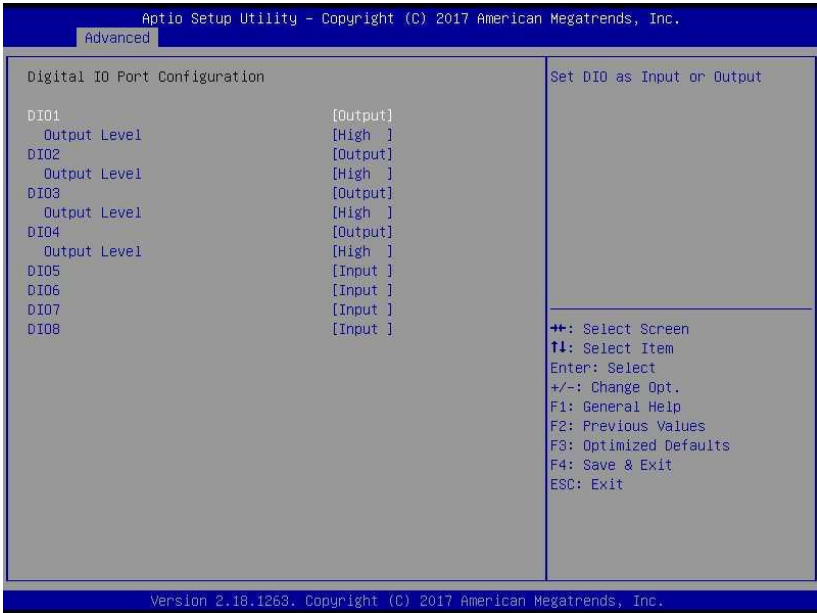

Options Summary		
DIO Type	Output	Optimal Default, Failsafe Default
	Input	
Set DIO as Input or Output		
DIO Data	Low	
	High	Optimal Default, Failsafe Default
Set is output level when DIO pin is output		

3.4.10 Power Management

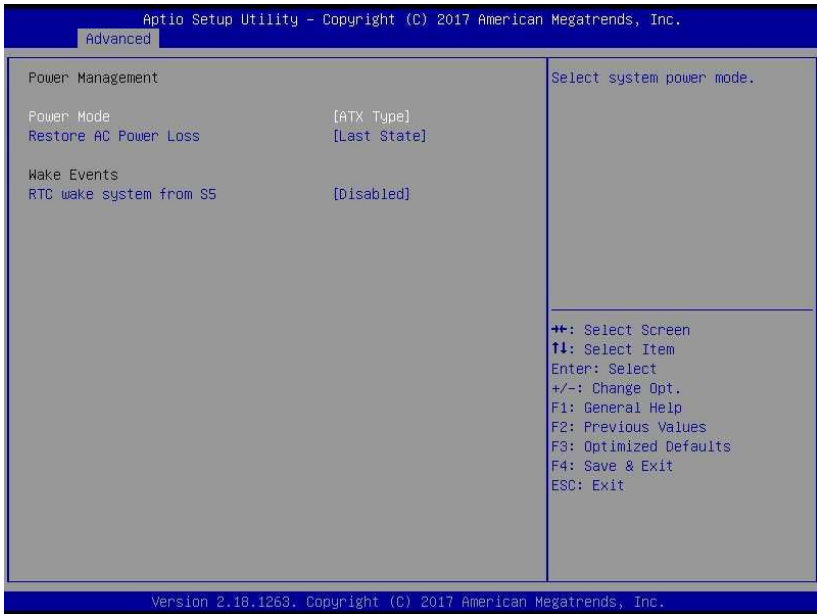

Options Summary		
Power Mode	ATX Type	Optimal Default, Failsafe Default
	AT Type	
Select power supply mode.		
AC Power Loss	Last State	Optimal Default, Failsafe Default
	Power On	
	Power Off	
Select power state when power is re-applied after a power failure.		
RTC wake system from S5	Disabled	Optimal Default, Failsafe Default
	Enabled	
Fixed Time: System will make on the hr::min::sec specified. Dynamic Time: System will wake on the current time + Increase minute(S)		
RTC wake system from S5	Enabled	
Wake up day	0	
Select 0 for daily system wake up, 1-31 for which day of the month that you would like system to wake up		

Options Summary	
Wake up hour	0
Select 0-23; For example: enter 3 for 3am and 15 for 3pm	
Wake up minute	0
0 - 59	
Wake up second	0
0 - 59	

3.5 Setup Submenu: Chipset

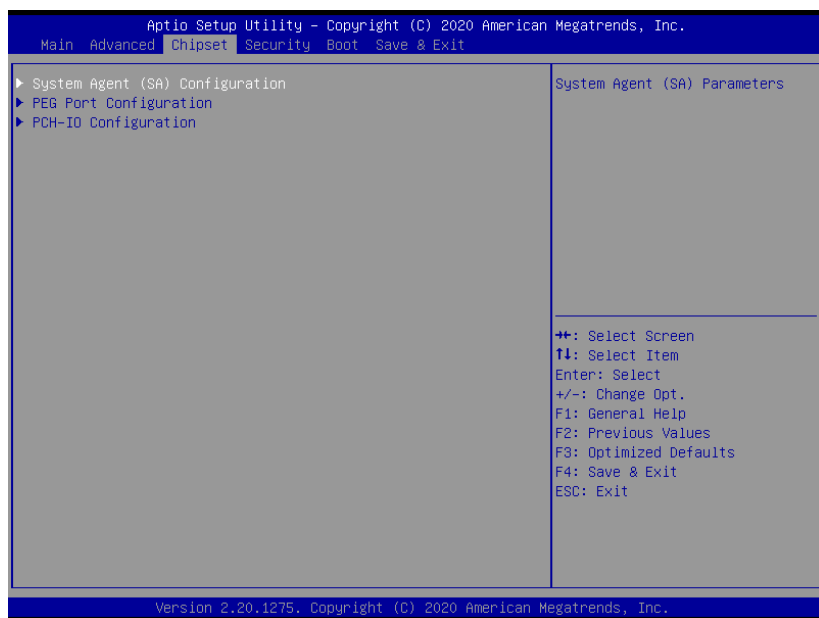

3.5.1 System Agent (SA) Configuration

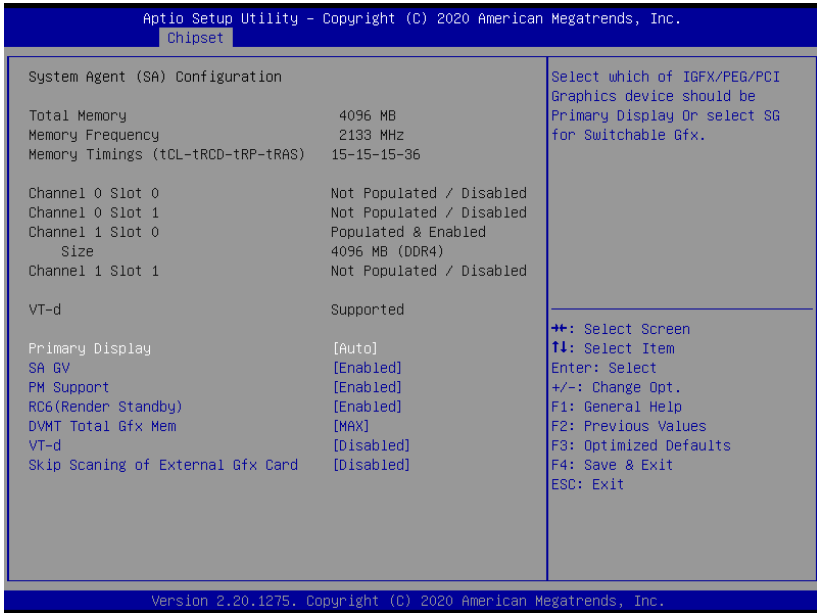

Options Summary		
Primary Display	Auto	Optimal Default; Failsafe Default
	IGFX	
	PEG	
Select which of IGFX/PEG/PCI Graphics device should be Primary Display Or select SG for Switchable Gfx.		
SA GV	Enabled	Optimal Default, Failsafe Default
	Disabled	
	Fixed Low	
	Fixed High	
System Agent Geyserville. Fixed Low/Mid/High: SA GV disabled, MRC only runs tasks from Low, Mid, or High point. SA GV will be disabled on DT/Halo CPUs, regardless of this setting.		
PM Support	Enabled	Optimal Default, Failsafe Default
	Disabled	
Enable/Disable PM Support.		

Options Summary		
RC6(Render Standby)	Enabled	Optimal Default, Failsafe Default
	Disabled	
Check to enable render standby support.		
DVMT Total Gfx Mem	128M	
	256M	
	MAX	Optimal Default, Failsafe Default
Select DVMT5.0 Total Graphic Memory sized used by the Internal Graphics Device.		
VT-d	Enabled	
	Disabled	Optimal Default, Failsafe Default
VT-d capability.		
Skip Scanning of External Gfx Card	Enabled	
	Disabled	Optimal Default, Failsafe Default
If Enabled, it will not scan for External Gfx Card on PEG and PCH PCIE Ports		

3.5.2 PEG Port Configuration

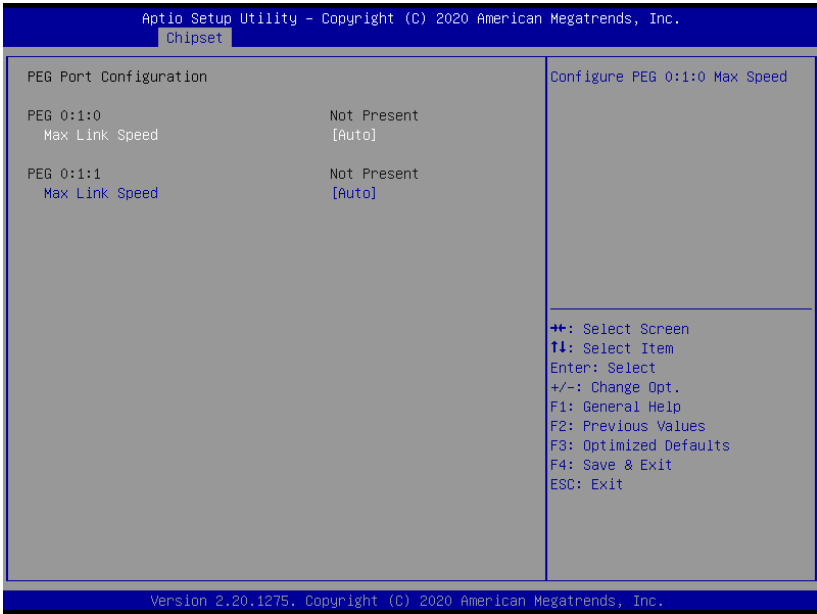

Options Summary		
Max Link Speed	Auto	Optimal Default, Failsafe Default
	Gen 1	
	Gen 2	
	Gen 3	
Configure PEG 0:1:0/0:1:1 Max Speed		

3.5.3 PCH-IO Configuration

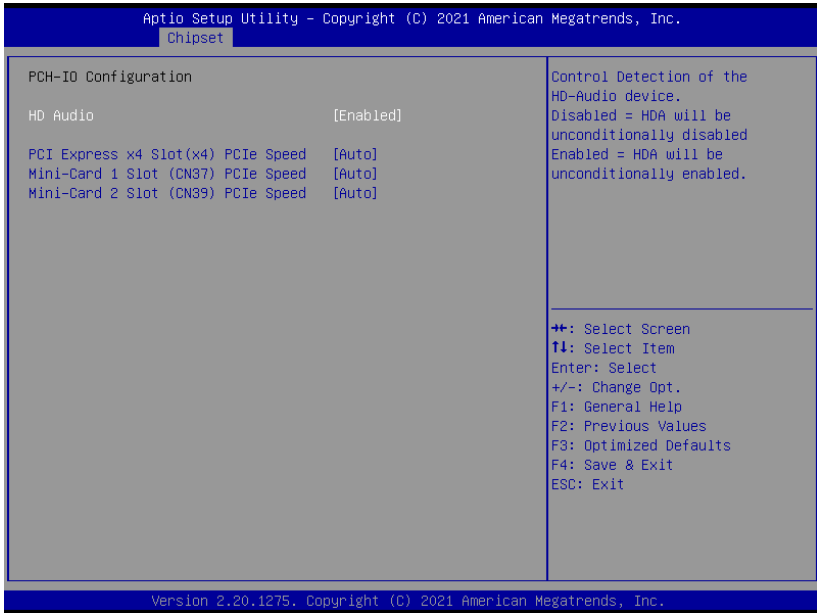

Options Summary		
HD Audio	Enabled	Optimal Default, Failsafe Default
	Disabled	
Control the Detection of the Audio device. Disabled = HDA will be unconditionally disabled. Enabled = HDA will be unconditionally enabled.		
PCI Express x4 Slot (x4) PCIe Speed	Auto	Optimal Default, Failsafe Default
	Gen 1	
	Gen 2	
	Gen 3	
Configure PCIe Speed.		
Mini-Card 1/ 2 Slot PCIe Speed	Auto	Optimal Default, Failsafe Default
	Gen 1	
	Gen 2	
Configure PCIe Speed.		

3.6 Setup Submenu: Security

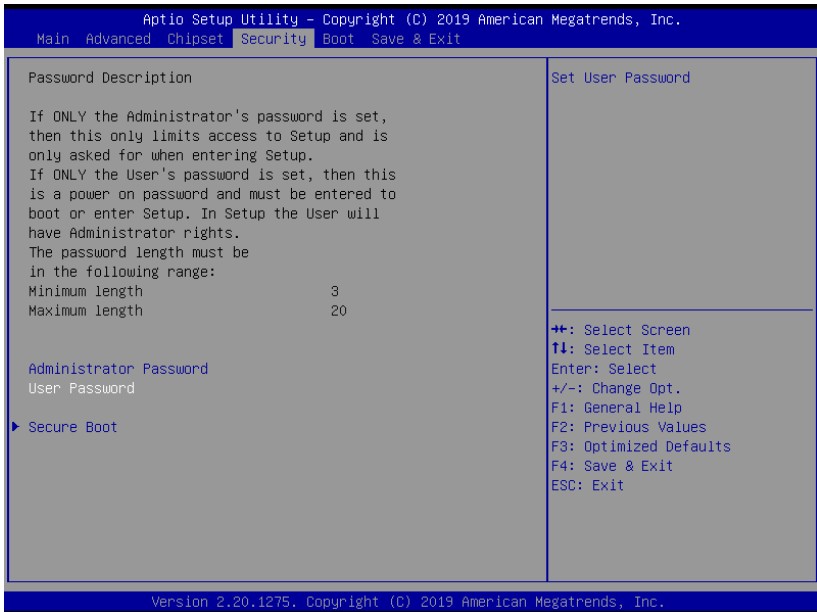

Change User/Administrator Password

You can set an Administrator Password or User Password. An Administrator Password must be set before you can set a User Password. The password will be required during boot up, or when the user enters the Setup utility. A User Password does not provide access to many of the features in the Setup utility.

Select the password you wish to set, and press Enter. In the dialog box, enter your password (must be between 3 and 20 letters or numbers). Press Enter and retype your password to confirm. Press Enter again to set the password.

Removing the Password

Select the password you want to remove and enter the current password. At the next dialog box press Enter to disable password protection.

3.6.1 Secure Boot

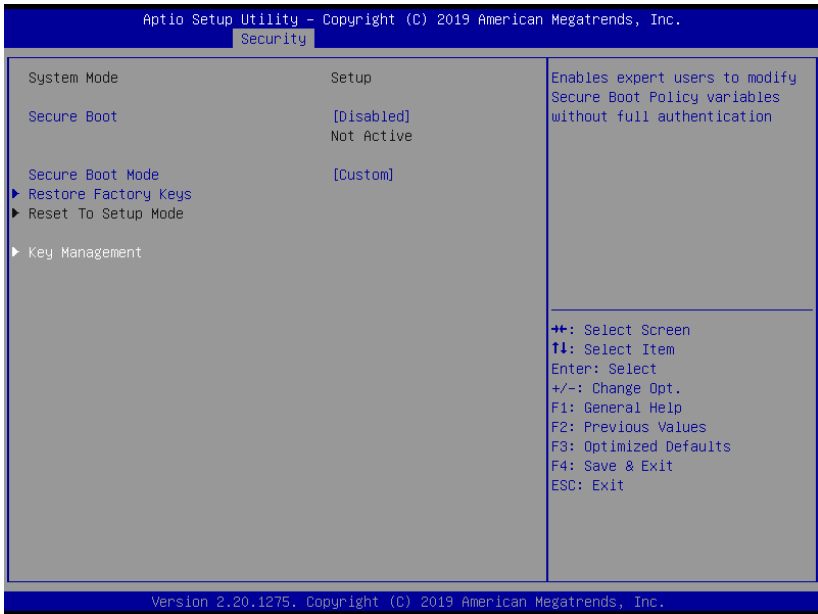

Options Summary		
Secure Boot	Disable	Optimal Default, Failsafe Default
	Enable	
Secure Boot feature is Active if Secure Boot is Enabled, Platform Key (PK) is enrolled and the System mode is in User mode. The mode change requires platform reset.		
Secure Boot Mode	Standard	
	Custom	Optimal Default, Failsafe Default
Secure Boot Mode options: Standard or Custom. In Custom mode, Secure Boot Policy variables can be configured by a physically present user without full authentication.		
Restore Factory Keys	Yes	
	No	
Force System to User Mode. Install factory default Secure Boot key databases		
Key Management		
Enables expert users to modify Secure Boot Policy variables without full authentication		

3.6.1.1 Key Management

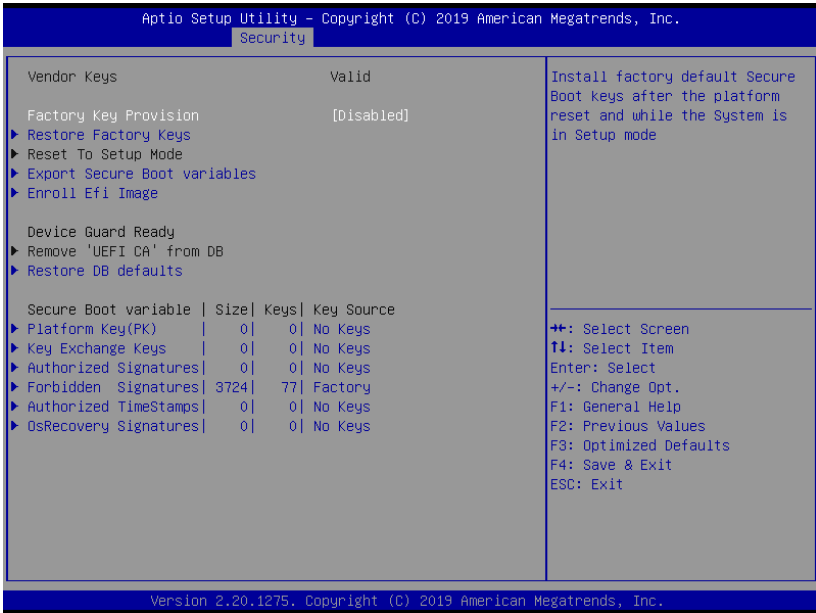

Options Summary		
Factory key Provision	Disabled	Optimal Default, Failsafe Default
	Enabled	
Install factory default Secure Boot keys after the platform reset and while the System is in Setup mode.		
Restore Factory Keys	No	Press 'Yes' to install factory default keys
	Yes	
Force System to User Mode. Install Factory default Secure Boot key databases.		
Export Secure Boot variables	Acpi(a0341d0, 0)\PCI(12 0)\DevicePath(Type 3, SubType 18)HD(Part2, Sig ?)\	
Copy NVRAM content of Secure Boot variables to files in a root folder on a file system device.		
Enroll Efi Image	Acpi(a0341d0, 0)\PCI(12 0)\DevicePath(Type 3, SubType 18)HD(Part2, Sig ?)\	
Allow the image to run in Secure Boot mode. Enroll SHA256 Hash Certificate of a PE Image into Authorized Signature Database (db).		

Secure Boot variable	Size	Keys#	key Source
Platform key (PK) 1153 1 No Key	Details	Enroll Factory Defaults or load certificates from a file: 1.Public key Certificate: a) EFI_SIGNATURE_LIST b) EFI_CERT_X509 (DER) c) EFI_CERT_RSA2048 (bin) d) EFI_CERT_SHAXXX 2.Authenticated UEFI Variable 3.EFI PE/COFF Image (SHA256) Key Source: Factory, External, Mixed	
	Export		
	Update		
	Delete		
Key Exchange keys 1153 1 No Key	Details	Enroll Factory Defaults or load certificates from a file: 1.Public key Certificate: a) EFI_SIGNATURE_LIST b) EFI_CERT_X509 (DER) c) EFI_CERT_RSA2048 (bin) d) EFI_CERT_SHAXXX 2.Authenticated UEFI Variable 3.EFI PE/COFF Image (SHA256) Key Source: Factory, External, Mixed	
	Export		
	Update		
	Append		
	Delete		
Authorized Signatures 4296 3 No Key	Details	Enroll Factory Defaults or load certificates from a file: 1.Public key Certificate: a) EFI_SIGNATURE_LIST b) EFI_CERT_X509 (DER) c) EFI_CERT_RSA2048 (bin) d) EFI_CERT_SHAXXX 2.Authenticated UEFI Variable 3.EFI PE/COFF Image (SHA256) Key Source: Factory, External, Mixed	
	Export		
	Update		
	Append		
	Delete		
Forbidden Signatures 3274 77 No Key	Details	Enroll Factory Defaults or load certificates from a file: 1.Public key Certificate: a) EFI_SIGNATURE_LIST b) EFI_CERT_X509 (DER) c) EFI_CERT_RSA2048 (bin) d) EFI_CERT_SHAXXX	
	Export		
	Update		

Secure Boot variable Size Keys# key Source		
	Append	2.Authenticated UEFI Variable 3.EFI PE/COFF Image (SHA256)
	Delete	Key Source: Factory, External, Mixed
Authorized TimeStamps 0 0 No Key	Update	Enroll Factory Defaults or load certificates from a file: 1.Public key Certificate: a) EFI_SIGNATURE_LIST b) EFI_CERT_X509 (DER) c) EFI_CERT_RSA2048 (bin) d) EFI_CERT_SHAXXX
	Append	2.Authenticated UEFI Variable 3.EFI PE/COFF Image (SHA256) Key Source: Factory, External, Mixed
OsRecovery Signatures 0 0 No Key	Update	Enroll Factory Defaults or load certificates from a file: 1.Public key Certificate: a) EFI_SIGNATURE_LIST b) EFI_CERT_X509 (DER) c) EFI_CERT_RSA2048 (bin) d) EFI_CERT_SHAXXX
	Append	2.Authenticated UEFI Variable 3.EFI PE/COFF Image (SHA256) Key Source: Factory, External, Mixed

3.7 Setup Submenu: Boot

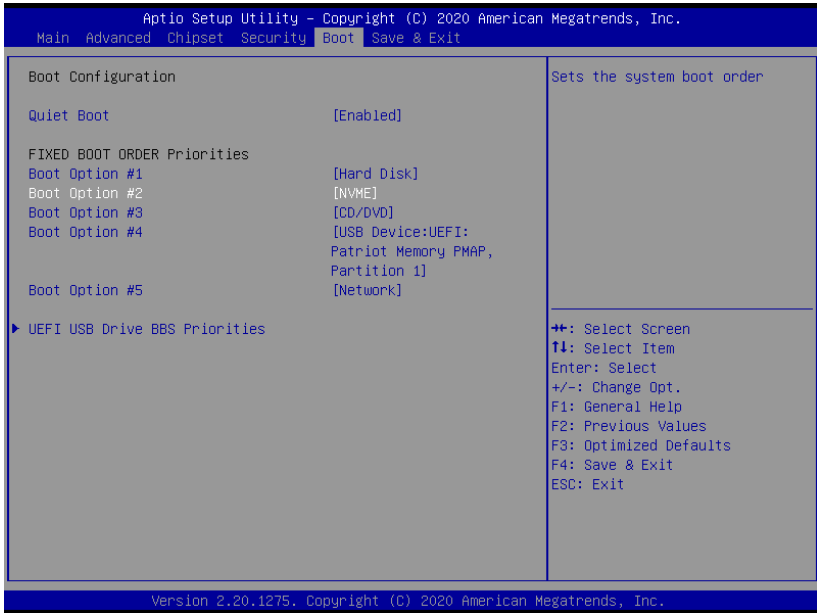

Options Summary		
Quiet Boot	Disabled	
	Enabled	Optimal Default, Failsafe Default
Enables or disables Quiet Boot option.		

3.8 Setup Submenu: Save & Exit

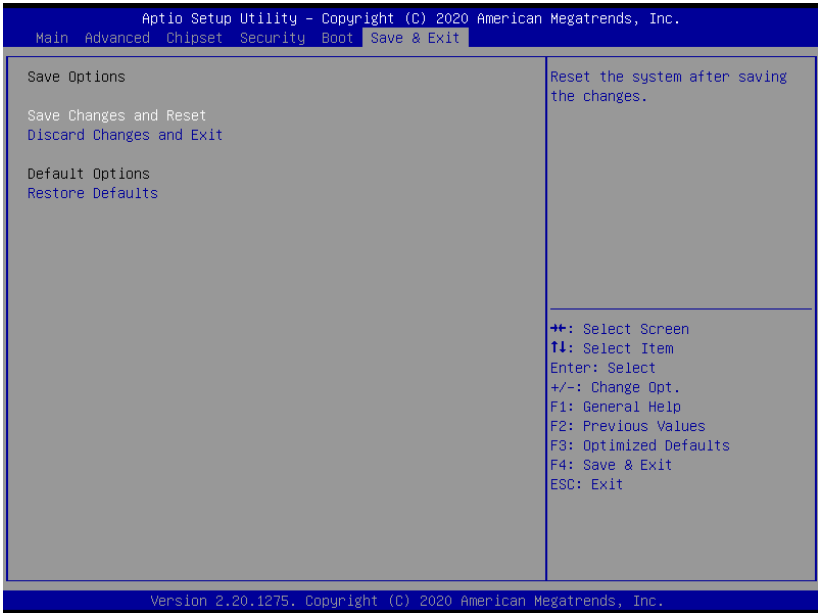

Chapter 4

Drivers Installation

4.1 Drivers Download and Installation

Drivers for the BOXER-8332AI can be downloaded from the product page on the AAEON website by following this link:

<https://www.aaeon.com/en/p/ai-edge-solution-boxer-8332ai-cfi>

Download the driver(s) you need and follow the steps below to install them.

Install Chipset Drivers

1. Unzip the Chipset driver zip file
2. Run the **SetupChipset.exe** file in the folder
3. Follow the instructions
4. Drivers will be installed automatically

Install Graphics Drivers

1. Unzip the Graphics driver zip file
2. Run the **igxpin.exe** file in the folder
3. Follow the instructions
4. Drivers will be installed automatically

Install ME Drivers

1. Unzip the ME driver zip file
2. Run the **SetupME.exe** file in the folder
3. Follow the instructions
4. Drivers will be installed automatically

Install LAN Drivers

1. Unzip the LAN driver zip file
2. Run the **PROWinx64.exe** file in the folder
3. Follow the instructions
4. Drivers will be installed automatically

Install Audio Drivers

1. Unzip the Audio driver zip file
2. Run the **0008-64bit_Win7_Win8_Win81_Win10_R281.exe** file in the folder
3. Follow the instructions
4. Drivers will be installed automatically

Install Intel RST Drivers

1. Unzip the Intel RST driver zip file
2. Run the **SetupRST.exe** file in the folder
3. Follow the instructions
4. Drivers will be installed automatically

Install Serial Port Drivers (Optional)

1. Unzip the Serial Port Driver zip file
2. Run the **FintekSerial.exe** file in the folder
3. Follow the instructions
4. Drivers will be installed automatically

Appendix A

Watchdog Timer Programming

A.1 Watchdog Timer Introduction

This section details the initial program setting for the Watchdog Timer program. If you have any questions or need support, please contact an AAEON representative by visiting the support page at AAEON.com

Please refer to the Linux Driver User Guide to access DIO, Watchdog Timer and Hardware Manager. The User Guide is available to download from the Drivers section of the product page.

A.2 Watchdog Timer Initial Program

Table 1: Super IO relative register table		
	Default Value	Note
Index	0x2E(Note1)	SIO MB PnP Mode Index Register 0x2E or 0x4E
Data	0x2F(Note2)	SIO MB PnP Mode Data Register 0x2F or 0x4F

Table 2: Watchdog relative register table					
	LDN	Register	BitNum	Value	Note
Timer Counter	0x07(Note3)	0xF6(Note4)		(Note24)	Time of watchdog timer (0~255) This register is byte access
Counting Unit	0x07(Note5)	0xF5(Note6)	3(Note7)	0(Note8)	Select time unit. 0: second 1: minute
Watchdog Enable	0x07(Note9)	0xF5(Note10)	5(Note11)	1(Note12)	0: Disable 1: Enable
Timeout Status	0x07(Note13)	0xF5(Note14)	6(Note15)	1	1: Clear timeout status
Output Mode	0x07(Note16)	0xF5(Note17)	4(Note18)	1(Note19)	Select WDTRST# output mode 0: level 1: pulse
WDTRST output	0x07(Note20)	0xFA(Note21)	0(Note22)	1(Note23)	Enable/Disable time out output via WDTRST# 0: Disable 1: Enable

```

*****
// SuperIO relative definition (Please reference to Table 1)
#define byte SIOIndex //This parameter is represented from Note1
#define byte SIOData //This parameter is represented from Note2
#define void IOWriteByte(byte IOPort, byte Value);
#define byte IOReadByte(byte IOPort);
// Watch Dog relative definition (Please reference to Table 2)
#define byte TimerLDN //This parameter is represented from Note3
#define byte TimerReg //This parameter is represented from Note4
#define byte TimerVal // This parameter is represented from Note24
#define byte UnitLDN //This parameter is represented from Note5
#define byte UnitReg //This parameter is represented from Note6
#define byte UnitBit //This parameter is represented from Note7
#define byte UnitVal //This parameter is represented from Note8
#define byte EnableLDN //This parameter is represented from Note9
#define byte EnableReg //This parameter is represented from Note10
#define byte EnableBit //This parameter is represented from Note11
#define byte EnableVal //This parameter is represented from Note12
#define byte StatusLDN // This parameter is represented from Note13
#define byte StatusReg // This parameter is represented from Note14
#define byte StatusBit // This parameter is represented from Note15
#define byte ModeLDN // This parameter is represented from Note16
#define byte ModeReg // This parameter is represented from Note17
#define byte ModeBit // This parameter is represented from Note18
#define byte ModeVal // This parameter is represented from Note19
#define byte WDRstLDN // This parameter is represented from Note20
#define byte WDRstReg // This parameter is represented from Note21
#define byte WDRstBit // This parameter is represented from Note22
#define byte WDRstVal // This parameter is represented from Note23
*****

```

```
*****
VOID Main() {
    // Procedure : AaeonWDTConfig
    // (byte)Timer : Time of WDT timer.(0x00~0xFF)
    // (boolean)Unit : Select time unit(0: second, 1: minute).
    AaeonWDTConfig();

    // Procedure : AaeonWDTEnable
    // This procedure will enable the WDT counting.
    AaeonWDTEnable();
}
*****
```

```

*****
// Procedure : AaeonWDTEnable
VOID AaeonWDTEnable (){
    WDTEnableDisable(EnableLDN, EnableReg, EnableBit, 1);
}

// Procedure : AaeonWDTConfig
VOID AaeonWDTConfig (){
    // Disable WDT counting
    WDTEnableDisable(EnableLDN, EnableReg, EnableBit, 0);
    // Clear Watchdog Timeout Status
    WDTClearTimeoutStatus();
    // WDT relative parameter setting
    WDTParameterSetting();
}

VOID WDTEnableDisable(byte LDN, byte Register, byte BitNum, byte Value){
    SIOBitSet(LDN, Register, BitNum, Value);
}

VOID WDTParameterSetting(){
    // Watchdog Timer counter setting
    SIOByteSet(TimerLDN, TimerReg, TimerVal);
    // WDT counting unit setting
    SIOBitSet(UnitLDN, UnitReg, UnitBit, UnitVal);
    // WDT output mode setting, level / pulse
    SIOBitSet(ModeLDN, ModeReg, ModeBit, ModeVal);
    // Watchdog timeout output via WDTRST#
    SIOBitSet(WDTRstLDN, WDTRstReg, WDTRstBit, WDTRstVal);
}

VOID WDTClearTimeoutStatus(){
    SIOBitSet(StatusLDN, StatusReg, StatusBit, 1);
}
*****

```

```

*****
VOID  SIOEnterMBPnPMode(){
    IOWriteByte(SIOIndex, 0x87);
    IOWriteByte(SIOIndex, 0x87);
}

VOID  SIOExitMBPnPMode(){
    IOWriteByte(SIOIndex, 0xAA);
}

VOID  SIOSelectLDN(byte LDN){
    IOWriteByte(SIOIndex, 0x07); // SIO LDN Register Offset = 0x07
    IOWriteByte(SIOData, LDN);
}

VOID  SIOBitSet(byte LDN, byte Register, byte BitNum, byte Value){
    Byte TmpValue;

    SIOEnterMBPnPMode();
    SIOSelectLDN(byte LDN);
    IOWriteByte(SIOIndex, Register);
    TmpValue = IOReadByte(SIOData);
    TmpValue &= ~(1 << BitNum);
    TmpValue |= (Value << BitNum);
    IOWriteByte(SIOData, TmpValue);
    SIOExitMBPnPMode();
}



































VOID  SIOByteSet(byte LDN, byte Register, byte Value){
    SIOEnterMBPnPMode();
    SIOSelectLDN(LDN);
    IOWriteByte(SIOIndex, Register);
    IOWriteByte(SIOData, Value);
    SIOExitMBPnPMode();
}
*****





















```

Appendix B

I/O Information















































B.1 I/O Address Map















































▼		Input/output (IO)
	[0000000000000000 - 000000000000CF7]	PCI Express Root Complex
	[0000000000000020 - 0000000000000021]	Programmable interrupt controller
	[0000000000000024 - 0000000000000025]	Programmable interrupt controller
	[0000000000000028 - 0000000000000029]	Programmable interrupt controller
	[000000000000002C - 000000000000002D]	Programmable interrupt controller
	[000000000000002E - 000000000000002F]	Motherboard resources
	[0000000000000030 - 0000000000000031]	Programmable interrupt controller
	[0000000000000034 - 0000000000000035]	Programmable interrupt controller
	[0000000000000038 - 0000000000000039]	Programmable interrupt controller
	[000000000000003C - 000000000000003D]	Programmable interrupt controller
	[0000000000000040 - 0000000000000043]	System timer
	[000000000000004E - 000000000000004F]	Motherboard resources
	[0000000000000050 - 0000000000000053]	System timer
	[0000000000000061 - 0000000000000061]	Motherboard resources
	[0000000000000063 - 0000000000000063]	Motherboard resources
	[0000000000000065 - 0000000000000065]	Motherboard resources
	[0000000000000067 - 0000000000000067]	Motherboard resources
	[0000000000000070 - 0000000000000070]	Motherboard resources
	[0000000000000080 - 0000000000000080]	Motherboard resources
	[0000000000000092 - 0000000000000092]	Motherboard resources
	[00000000000000A0 - 00000000000000A1]	Programmable interrupt controller
	[00000000000000A4 - 00000000000000A5]	Programmable interrupt controller
	[00000000000000A8 - 00000000000000A9]	Programmable interrupt controller
	[00000000000000AC - 00000000000000AD]	Programmable interrupt controller
	[00000000000000B0 - 00000000000000B1]	Programmable interrupt controller
	[00000000000000B2 - 00000000000000B3]	Motherboard resources
	[00000000000000B4 - 00000000000000B5]	Programmable interrupt controller
	[00000000000000B8 - 00000000000000B9]	Programmable interrupt controller
	[00000000000000BC - 00000000000000BD]	Programmable interrupt controller
	[00000000000000F0 - 00000000000000F0]	Numeric data processor
	[00000000000002E8 - 00000000000002EF]	Fintek Communications Port (COM4)
	[00000000000002F8 - 00000000000002FF]	Fintek Communications Port (COM2)
	[00000000000003E8 - 00000000000003EF]	Fintek Communications Port (COM3)
	[00000000000003F8 - 00000000000003FF]	Fintek Communications Port (COM1)















































	[00000000000004D0 - 0000000000004D1]	Programmable interrupt controller
	[0000000000000680 - 00000000000069F]	Motherboard resources
	[0000000000000A00 - 000000000000A0F]	Motherboard resources
	[0000000000000A10 - 000000000000A1F]	Motherboard resources
	[0000000000000A20 - 000000000000A2F]	Motherboard resources
	[0000000000000D00 - 000000000000FFFF]	PCI Express Root Complex
	[000000000000164E - 000000000000164F]	Motherboard resources
	[0000000000001800 - 00000000000018FE]	Motherboard resources
	[0000000000001854 - 0000000000001857]	Motherboard resources
	[0000000000002000 - 00000000000020FE]	Motherboard resources
	[0000000000003000 - 0000000000003FFF]	Intel(R) PCI Express Root Port #8 - A33F
	[0000000000004000 - 0000000000004FFF]	Intel(R) PCI Express Root Port #7 - A33E
	[0000000000005000 - 000000000000503F]	Intel(R) UHD Graphics 630
	[0000000000005060 - 000000000000507F]	Intel(R) 300 Series Chipset Family SATA AHCI Controller
	[0000000000005080 - 0000000000005083]	Intel(R) 300 Series Chipset Family SATA AHCI Controller
	[0000000000005090 - 0000000000005097]	Intel(R) 300 Series Chipset Family SATA AHCI Controller
	[000000000000EFA0 - 000000000000EFBF]	Intel(R) SMBus - A323
	[000000000000FFF8 - 000000000000FFFF]	Intel(R) Active Management Technology - SOL (COM5)
>		Interrupt request (IRQ)
>		Memory















































B.2 IRQ Mapping Chart















































DESKTOP-GP2JDP2	
Input/output (I/O)	
Interrupt request (IRQ)	
(ISA) 0x00000000 (00)	System timer
(ISA) 0x00000003 (03)	Fintek Communications Port (COM2)
(ISA) 0x00000004 (04)	Fintek Communications Port (COM1)
(ISA) 0x0000000B (11)	Fintek Communications Port (COM3)
(ISA) 0x0000000B (11)	Fintek Communications Port (COM4)
(ISA) 0x0000000D (13)	Numeric data processor
(ISA) 0x0000000E (14)	Intel(R) Serial IO GPIO Host Controller - INT3450
(ISA) 0x00000036 (54)	Microsoft ACPI-Compliant System
(ISA) 0x00000037 (55)	Microsoft ACPI-Compliant System
(ISA) 0x00000038 (56)	Microsoft ACPI-Compliant System
(ISA) 0x00000039 (57)	Microsoft ACPI-Compliant System
(ISA) 0x0000003A (58)	Microsoft ACPI-Compliant System
(ISA) 0x0000003B (59)	Microsoft ACPI-Compliant System
(ISA) 0x0000003C (60)	Microsoft ACPI-Compliant System
(ISA) 0x0000003D (61)	Microsoft ACPI-Compliant System
(ISA) 0x0000003E (62)	Microsoft ACPI-Compliant System
(ISA) 0x0000003F (63)	Microsoft ACPI-Compliant System
(ISA) 0x00000040 (64)	Microsoft ACPI-Compliant System
(ISA) 0x00000041 (65)	Microsoft ACPI-Compliant System
(ISA) 0x00000042 (66)	Microsoft ACPI-Compliant System
(ISA) 0x00000043 (67)	Microsoft ACPI-Compliant System
(ISA) 0x00000044 (68)	Microsoft ACPI-Compliant System
(ISA) 0x00000045 (69)	Microsoft ACPI-Compliant System
(ISA) 0x00000046 (70)	Microsoft ACPI-Compliant System
(ISA) 0x00000047 (71)	Microsoft ACPI-Compliant System
(ISA) 0x00000048 (72)	Microsoft ACPI-Compliant System
(ISA) 0x00000049 (73)	Microsoft ACPI-Compliant System
(ISA) 0x0000004A (74)	Microsoft ACPI-Compliant System
(ISA) 0x0000004B (75)	Microsoft ACPI-Compliant System
(ISA) 0x0000004C (76)	Microsoft ACPI-Compliant System
(ISA) 0x0000004D (77)	Microsoft ACPI-Compliant System
(ISA) 0x0000004E (78)	Microsoft ACPI-Compliant System
(ISA) 0x0000004F (79)	Microsoft ACPI-Compliant System
(ISA) 0x00000050 (80)	Microsoft ACPI-Compliant System
(ISA) 0x00000051 (81)	Microsoft ACPI-Compliant System
(ISA) 0x00000052 (82)	Microsoft ACPI-Compliant System
(ISA) 0x00000053 (83)	Microsoft ACPI-Compliant System
(ISA) 0x00000054 (84)	Microsoft ACPI-Compliant System
(ISA) 0x00000055 (85)	Microsoft ACPI-Compliant System
(ISA) 0x00000056 (86)	Microsoft ACPI-Compliant System
(ISA) 0x00000057 (87)	Microsoft ACPI-Compliant System
(ISA) 0x00000058 (88)	Microsoft ACPI-Compliant System
(ISA) 0x00000059 (89)	Microsoft ACPI-Compliant System
(ISA) 0x0000005A (90)	Microsoft ACPI-Compliant System
(ISA) 0x0000005B (91)	Microsoft ACPI-Compliant System
(ISA) 0x0000005C (92)	Microsoft ACPI-Compliant System

















































 (ISA) 0x0000005D (93)	Microsoft ACPI-Compliant System
 (ISA) 0x0000005E (94)	Microsoft ACPI-Compliant System
 (ISA) 0x0000005F (95)	Microsoft ACPI-Compliant System
 (ISA) 0x00000060 (96)	Microsoft ACPI-Compliant System
 (ISA) 0x00000061 (97)	Microsoft ACPI-Compliant System
 (ISA) 0x00000062 (98)	Microsoft ACPI-Compliant System
 (ISA) 0x00000063 (99)	Microsoft ACPI-Compliant System
 (ISA) 0x00000064 (100)	Microsoft ACPI-Compliant System
 (ISA) 0x00000065 (101)	Microsoft ACPI-Compliant System
 (ISA) 0x00000066 (102)	Microsoft ACPI-Compliant System
 (ISA) 0x00000067 (103)	Microsoft ACPI-Compliant System
 (ISA) 0x00000068 (104)	Microsoft ACPI-Compliant System
 (ISA) 0x00000069 (105)	Microsoft ACPI-Compliant System
 (ISA) 0x0000006A (106)	Microsoft ACPI-Compliant System
 (ISA) 0x0000006B (107)	Microsoft ACPI-Compliant System
 (ISA) 0x0000006C (108)	Microsoft ACPI-Compliant System
 (ISA) 0x0000006D (109)	Microsoft ACPI-Compliant System
 (ISA) 0x0000006E (110)	Microsoft ACPI-Compliant System
 (ISA) 0x0000006F (111)	Microsoft ACPI-Compliant System
 (ISA) 0x00000070 (112)	Microsoft ACPI-Compliant System
 (ISA) 0x00000071 (113)	Microsoft ACPI-Compliant System
 (ISA) 0x00000072 (114)	Microsoft ACPI-Compliant System
 (ISA) 0x00000073 (115)	Microsoft ACPI-Compliant System
 (ISA) 0x00000074 (116)	Microsoft ACPI-Compliant System
 (ISA) 0x00000075 (117)	Microsoft ACPI-Compliant System
 (ISA) 0x00000076 (118)	Microsoft ACPI-Compliant System
 (ISA) 0x00000077 (119)	Microsoft ACPI-Compliant System
 (ISA) 0x00000078 (120)	Microsoft ACPI-Compliant System
 (ISA) 0x00000079 (121)	Microsoft ACPI-Compliant System
 (ISA) 0x0000007A (122)	Microsoft ACPI-Compliant System
 (ISA) 0x0000007B (123)	Microsoft ACPI-Compliant System
 (ISA) 0x0000007C (124)	Microsoft ACPI-Compliant System
 (ISA) 0x0000007D (125)	Microsoft ACPI-Compliant System
 (ISA) 0x0000007E (126)	Microsoft ACPI-Compliant System
 (ISA) 0x0000007F (127)	Microsoft ACPI-Compliant System
 (ISA) 0x00000080 (128)	Microsoft ACPI-Compliant System
 (ISA) 0x00000081 (129)	Microsoft ACPI-Compliant System
 (ISA) 0x00000082 (130)	Microsoft ACPI-Compliant System
 (ISA) 0x00000083 (131)	Microsoft ACPI-Compliant System
 (ISA) 0x00000084 (132)	Microsoft ACPI-Compliant System
 (ISA) 0x00000085 (133)	Microsoft ACPI-Compliant System
 (ISA) 0x00000086 (134)	Microsoft ACPI-Compliant System
 (ISA) 0x00000087 (135)	Microsoft ACPI-Compliant System
 (ISA) 0x00000088 (136)	Microsoft ACPI-Compliant System
 (ISA) 0x00000089 (137)	Microsoft ACPI-Compliant System
 (ISA) 0x0000008A (138)	Microsoft ACPI-Compliant System
 (ISA) 0x0000008B (139)	Microsoft ACPI-Compliant System
(ISA) 0x0000008C (140)	Microsoft ACPI-Compliant System















































 (ISA) 0x0000008D (141)	Microsoft ACPI-Compliant System
 (ISA) 0x0000008E (142)	Microsoft ACPI-Compliant System
 (ISA) 0x0000008F (143)	Microsoft ACPI-Compliant System
 (ISA) 0x00000090 (144)	Microsoft ACPI-Compliant System
 (ISA) 0x00000091 (145)	Microsoft ACPI-Compliant System
 (ISA) 0x00000092 (146)	Microsoft ACPI-Compliant System
 (ISA) 0x00000093 (147)	Microsoft ACPI-Compliant System
 (ISA) 0x00000094 (148)	Microsoft ACPI-Compliant System
 (ISA) 0x00000095 (149)	Microsoft ACPI-Compliant System
 (ISA) 0x00000096 (150)	Microsoft ACPI-Compliant System
 (ISA) 0x00000097 (151)	Microsoft ACPI-Compliant System
 (ISA) 0x00000098 (152)	Microsoft ACPI-Compliant System
 (ISA) 0x00000099 (153)	Microsoft ACPI-Compliant System
 (ISA) 0x0000009A (154)	Microsoft ACPI-Compliant System
 (ISA) 0x0000009B (155)	Microsoft ACPI-Compliant System
 (ISA) 0x0000009C (156)	Microsoft ACPI-Compliant System
 (ISA) 0x0000009D (157)	Microsoft ACPI-Compliant System
 (ISA) 0x0000009E (158)	Microsoft ACPI-Compliant System
 (ISA) 0x0000009F (159)	Microsoft ACPI-Compliant System
 (ISA) 0x000000A0 (160)	Microsoft ACPI-Compliant System
 (ISA) 0x000000A1 (161)	Microsoft ACPI-Compliant System
 (ISA) 0x000000A2 (162)	Microsoft ACPI-Compliant System
 (ISA) 0x000000A3 (163)	Microsoft ACPI-Compliant System
 (ISA) 0x000000A4 (164)	Microsoft ACPI-Compliant System
 (ISA) 0x000000A5 (165)	Microsoft ACPI-Compliant System
 (ISA) 0x000000A6 (166)	Microsoft ACPI-Compliant System
 (ISA) 0x000000A7 (167)	Microsoft ACPI-Compliant System
 (ISA) 0x000000A8 (168)	Microsoft ACPI-Compliant System
 (ISA) 0x000000A9 (169)	Microsoft ACPI-Compliant System
 (ISA) 0x000000AA (170)	Microsoft ACPI-Compliant System
 (ISA) 0x000000AB (171)	Microsoft ACPI-Compliant System
 (ISA) 0x000000AC (172)	Microsoft ACPI-Compliant System
 (ISA) 0x000000AD (173)	Microsoft ACPI-Compliant System
 (ISA) 0x000000AE (174)	Microsoft ACPI-Compliant System
 (ISA) 0x000000AF (175)	Microsoft ACPI-Compliant System
 (ISA) 0x000000B0 (176)	Microsoft ACPI-Compliant System
 (ISA) 0x000000B1 (177)	Microsoft ACPI-Compliant System
 (ISA) 0x000000B2 (178)	Microsoft ACPI-Compliant System
 (ISA) 0x000000B3 (179)	Microsoft ACPI-Compliant System
 (ISA) 0x000000B4 (180)	Microsoft ACPI-Compliant System
 (ISA) 0x000000B5 (181)	Microsoft ACPI-Compliant System
 (ISA) 0x000000B6 (182)	Microsoft ACPI-Compliant System
 (ISA) 0x000000B7 (183)	Microsoft ACPI-Compliant System
 (ISA) 0x000000B8 (184)	Microsoft ACPI-Compliant System
 (ISA) 0x000000B9 (185)	Microsoft ACPI-Compliant System
 (ISA) 0x000000BA (186)	Microsoft ACPI-Compliant System
 (ISA) 0x000000BB (187)	Microsoft ACPI-Compliant System
(ISA) 0x000000BC (188)	Microsoft ACPI-Compliant System















































 (ISA) 0x000000BD (189)	Microsoft ACPI-Compliant System
 (ISA) 0x000000BE (190)	Microsoft ACPI-Compliant System
 (ISA) 0x000000BF (191)	Microsoft ACPI-Compliant System
 (ISA) 0x000000C0 (192)	Microsoft ACPI-Compliant System
 (ISA) 0x000000C1 (193)	Microsoft ACPI-Compliant System
 (ISA) 0x000000C2 (194)	Microsoft ACPI-Compliant System
 (ISA) 0x000000C3 (195)	Microsoft ACPI-Compliant System
 (ISA) 0x000000C4 (196)	Microsoft ACPI-Compliant System
 (ISA) 0x000000C5 (197)	Microsoft ACPI-Compliant System
 (ISA) 0x000000C6 (198)	Microsoft ACPI-Compliant System
 (ISA) 0x000000C7 (199)	Microsoft ACPI-Compliant System
 (ISA) 0x000000C8 (200)	Microsoft ACPI-Compliant System
 (ISA) 0x000000C9 (201)	Microsoft ACPI-Compliant System
 (ISA) 0x000000CA (202)	Microsoft ACPI-Compliant System
 (ISA) 0x000000CB (203)	Microsoft ACPI-Compliant System
 (ISA) 0x000000CC (204)	Microsoft ACPI-Compliant System
 (ISA) 0x00000100 (256)	Microsoft ACPI-Compliant System
 (ISA) 0x00000101 (257)	Microsoft ACPI-Compliant System
 (ISA) 0x00000102 (258)	Microsoft ACPI-Compliant System
 (ISA) 0x00000103 (259)	Microsoft ACPI-Compliant System
 (ISA) 0x00000104 (260)	Microsoft ACPI-Compliant System
 (ISA) 0x00000105 (261)	Microsoft ACPI-Compliant System
 (ISA) 0x00000106 (262)	Microsoft ACPI-Compliant System
 (ISA) 0x00000107 (263)	Microsoft ACPI-Compliant System
 (ISA) 0x00000108 (264)	Microsoft ACPI-Compliant System
 (ISA) 0x00000109 (265)	Microsoft ACPI-Compliant System
 (ISA) 0x0000010A (266)	Microsoft ACPI-Compliant System
 (ISA) 0x0000010B (267)	Microsoft ACPI-Compliant System
 (ISA) 0x0000010C (268)	Microsoft ACPI-Compliant System
 (ISA) 0x0000010D (269)	Microsoft ACPI-Compliant System
 (ISA) 0x0000010E (270)	Microsoft ACPI-Compliant System
 (ISA) 0x0000010F (271)	Microsoft ACPI-Compliant System
 (ISA) 0x00000110 (272)	Microsoft ACPI-Compliant System
 (ISA) 0x00000111 (273)	Microsoft ACPI-Compliant System
 (ISA) 0x00000112 (274)	Microsoft ACPI-Compliant System
 (ISA) 0x00000113 (275)	Microsoft ACPI-Compliant System
 (ISA) 0x00000114 (276)	Microsoft ACPI-Compliant System
 (ISA) 0x00000115 (277)	Microsoft ACPI-Compliant System
 (ISA) 0x00000116 (278)	Microsoft ACPI-Compliant System
 (ISA) 0x00000117 (279)	Microsoft ACPI-Compliant System
 (ISA) 0x00000118 (280)	Microsoft ACPI-Compliant System
 (ISA) 0x00000119 (281)	Microsoft ACPI-Compliant System
 (ISA) 0x0000011A (282)	Microsoft ACPI-Compliant System
 (ISA) 0x0000011B (283)	Microsoft ACPI-Compliant System
 (ISA) 0x0000011C (284)	Microsoft ACPI-Compliant System
 (ISA) 0x0000011D (285)	Microsoft ACPI-Compliant System
 (ISA) 0x0000011E (286)	Microsoft ACPI-Compliant System
(ISA) 0x0000011F (287)	Microsoft ACPI-Compliant System









	(ISA) 0x00000120 (288)	Microsoft ACPI-Compliant System
	(ISA) 0x00000121 (289)	Microsoft ACPI-Compliant System
	(ISA) 0x00000122 (290)	Microsoft ACPI-Compliant System
	(ISA) 0x00000123 (291)	Microsoft ACPI-Compliant System
	(ISA) 0x00000124 (292)	Microsoft ACPI-Compliant System
	(ISA) 0x00000125 (293)	Microsoft ACPI-Compliant System
	(ISA) 0x00000126 (294)	Microsoft ACPI-Compliant System
	(ISA) 0x00000127 (295)	Microsoft ACPI-Compliant System
	(ISA) 0x00000128 (296)	Microsoft ACPI-Compliant System
	(ISA) 0x00000129 (297)	Microsoft ACPI-Compliant System
	(ISA) 0x0000012A (298)	Microsoft ACPI-Compliant System
	(ISA) 0x0000012B (299)	Microsoft ACPI-Compliant System
	(ISA) 0x0000012C (300)	Microsoft ACPI-Compliant System
	(ISA) 0x0000012D (301)	Microsoft ACPI-Compliant System
	(ISA) 0x0000012E (302)	Microsoft ACPI-Compliant System
	(ISA) 0x0000012F (303)	Microsoft ACPI-Compliant System
	(ISA) 0x00000130 (304)	Microsoft ACPI-Compliant System
	(ISA) 0x00000131 (305)	Microsoft ACPI-Compliant System
	(ISA) 0x00000132 (306)	Microsoft ACPI-Compliant System
	(ISA) 0x00000133 (307)	Microsoft ACPI-Compliant System
	(ISA) 0x00000134 (308)	Microsoft ACPI-Compliant System
	(ISA) 0x00000135 (309)	Microsoft ACPI-Compliant System
	(ISA) 0x00000136 (310)	Microsoft ACPI-Compliant System
	(ISA) 0x00000137 (311)	Microsoft ACPI-Compliant System
	(ISA) 0x00000138 (312)	Microsoft ACPI-Compliant System
	(ISA) 0x00000139 (313)	Microsoft ACPI-Compliant System
	(ISA) 0x0000013A (314)	Microsoft ACPI-Compliant System
	(ISA) 0x0000013B (315)	Microsoft ACPI-Compliant System
	(ISA) 0x0000013C (316)	Microsoft ACPI-Compliant System
	(ISA) 0x0000013D (317)	Microsoft ACPI-Compliant System
	(ISA) 0x0000013E (318)	Microsoft ACPI-Compliant System
	(ISA) 0x0000013F (319)	Microsoft ACPI-Compliant System
	(ISA) 0x00000140 (320)	Microsoft ACPI-Compliant System
	(ISA) 0x00000141 (321)	Microsoft ACPI-Compliant System
	(ISA) 0x00000142 (322)	Microsoft ACPI-Compliant System
	(ISA) 0x00000143 (323)	Microsoft ACPI-Compliant System
	(ISA) 0x00000144 (324)	Microsoft ACPI-Compliant System
	(ISA) 0x00000145 (325)	Microsoft ACPI-Compliant System
	(ISA) 0x00000146 (326)	Microsoft ACPI-Compliant System
	(ISA) 0x00000147 (327)	Microsoft ACPI-Compliant System
	(ISA) 0x00000148 (328)	Microsoft ACPI-Compliant System
	(ISA) 0x00000149 (329)	Microsoft ACPI-Compliant System
	(ISA) 0x0000014A (330)	Microsoft ACPI-Compliant System
	(ISA) 0x0000014B (331)	Microsoft ACPI-Compliant System
	(ISA) 0x0000014C (332)	Microsoft ACPI-Compliant System
	(ISA) 0x0000014D (333)	Microsoft ACPI-Compliant System
	(ISA) 0x0000014E (334)	Microsoft ACPI-Compliant System
	(ISA) 0x0000014F (335)	Microsoft ACPI-Compliant System

 (ISA) 0x00000150 (336)	Microsoft ACPI-Compliant System
 (ISA) 0x00000151 (337)	Microsoft ACPI-Compliant System
 (ISA) 0x00000152 (338)	Microsoft ACPI-Compliant System
 (ISA) 0x00000153 (339)	Microsoft ACPI-Compliant System
 (ISA) 0x00000154 (340)	Microsoft ACPI-Compliant System
 (ISA) 0x00000155 (341)	Microsoft ACPI-Compliant System
 (ISA) 0x00000156 (342)	Microsoft ACPI-Compliant System
 (ISA) 0x00000157 (343)	Microsoft ACPI-Compliant System
 (ISA) 0x00000158 (344)	Microsoft ACPI-Compliant System
 (ISA) 0x00000159 (345)	Microsoft ACPI-Compliant System
 (ISA) 0x0000015A (346)	Microsoft ACPI-Compliant System
 (ISA) 0x0000015B (347)	Microsoft ACPI-Compliant System
 (ISA) 0x0000015C (348)	Microsoft ACPI-Compliant System
 (ISA) 0x0000015D (349)	Microsoft ACPI-Compliant System
 (ISA) 0x0000015E (350)	Microsoft ACPI-Compliant System
 (ISA) 0x0000015F (351)	Microsoft ACPI-Compliant System
 (ISA) 0x00000160 (352)	Microsoft ACPI-Compliant System
 (ISA) 0x00000161 (353)	Microsoft ACPI-Compliant System
 (ISA) 0x00000162 (354)	Microsoft ACPI-Compliant System
 (ISA) 0x00000163 (355)	Microsoft ACPI-Compliant System
 (ISA) 0x00000164 (356)	Microsoft ACPI-Compliant System
 (ISA) 0x00000165 (357)	Microsoft ACPI-Compliant System
 (ISA) 0x00000166 (358)	Microsoft ACPI-Compliant System
 (ISA) 0x00000167 (359)	Microsoft ACPI-Compliant System
 (ISA) 0x00000168 (360)	Microsoft ACPI-Compliant System
 (ISA) 0x00000169 (361)	Microsoft ACPI-Compliant System
 (ISA) 0x0000016A (362)	Microsoft ACPI-Compliant System
 (ISA) 0x0000016B (363)	Microsoft ACPI-Compliant System
 (ISA) 0x0000016C (364)	Microsoft ACPI-Compliant System
 (ISA) 0x0000016D (365)	Microsoft ACPI-Compliant System
 (ISA) 0x0000016E (366)	Microsoft ACPI-Compliant System
 (ISA) 0x0000016F (367)	Microsoft ACPI-Compliant System
 (ISA) 0x00000170 (368)	Microsoft ACPI-Compliant System
 (ISA) 0x00000171 (369)	Microsoft ACPI-Compliant System
 (ISA) 0x00000172 (370)	Microsoft ACPI-Compliant System
 (ISA) 0x00000173 (371)	Microsoft ACPI-Compliant System
 (ISA) 0x00000174 (372)	Microsoft ACPI-Compliant System
 (ISA) 0x00000175 (373)	Microsoft ACPI-Compliant System
 (ISA) 0x00000176 (374)	Microsoft ACPI-Compliant System
 (ISA) 0x00000177 (375)	Microsoft ACPI-Compliant System
 (ISA) 0x00000178 (376)	Microsoft ACPI-Compliant System
 (ISA) 0x00000179 (377)	Microsoft ACPI-Compliant System
 (ISA) 0x0000017A (378)	Microsoft ACPI-Compliant System
 (ISA) 0x0000017B (379)	Microsoft ACPI-Compliant System
 (ISA) 0x0000017C (380)	Microsoft ACPI-Compliant System
 (ISA) 0x0000017D (381)	Microsoft ACPI-Compliant System
(ISA) 0x0000017E (382)	Microsoft ACPI-Compliant System
(ISA) 0x0000017F (383)	Microsoft ACPI-Compliant System

 (ISA) 0x00000180 (384)	Microsoft ACPI-Compliant System
 (ISA) 0x00000181 (385)	Microsoft ACPI-Compliant System
 (ISA) 0x00000182 (386)	Microsoft ACPI-Compliant System
 (ISA) 0x00000183 (387)	Microsoft ACPI-Compliant System
 (ISA) 0x00000184 (388)	Microsoft ACPI-Compliant System
 (ISA) 0x00000185 (389)	Microsoft ACPI-Compliant System
 (ISA) 0x00000186 (390)	Microsoft ACPI-Compliant System
 (ISA) 0x00000187 (391)	Microsoft ACPI-Compliant System
 (ISA) 0x00000188 (392)	Microsoft ACPI-Compliant System
 (ISA) 0x00000189 (393)	Microsoft ACPI-Compliant System
 (ISA) 0x0000018A (394)	Microsoft ACPI-Compliant System
 (ISA) 0x0000018B (395)	Microsoft ACPI-Compliant System
 (ISA) 0x0000018C (396)	Microsoft ACPI-Compliant System
 (ISA) 0x0000018D (397)	Microsoft ACPI-Compliant System
 (ISA) 0x0000018E (398)	Microsoft ACPI-Compliant System
 (ISA) 0x0000018F (399)	Microsoft ACPI-Compliant System
 (ISA) 0x00000190 (400)	Microsoft ACPI-Compliant System
 (ISA) 0x00000191 (401)	Microsoft ACPI-Compliant System
 (ISA) 0x00000192 (402)	Microsoft ACPI-Compliant System
 (ISA) 0x00000193 (403)	Microsoft ACPI-Compliant System
 (ISA) 0x00000194 (404)	Microsoft ACPI-Compliant System
 (ISA) 0x00000195 (405)	Microsoft ACPI-Compliant System
 (ISA) 0x00000196 (406)	Microsoft ACPI-Compliant System
 (ISA) 0x00000197 (407)	Microsoft ACPI-Compliant System
 (ISA) 0x00000198 (408)	Microsoft ACPI-Compliant System
 (ISA) 0x00000199 (409)	Microsoft ACPI-Compliant System
 (ISA) 0x0000019A (410)	Microsoft ACPI-Compliant System
 (ISA) 0x0000019B (411)	Microsoft ACPI-Compliant System
 (ISA) 0x0000019C (412)	Microsoft ACPI-Compliant System
 (ISA) 0x0000019D (413)	Microsoft ACPI-Compliant System
 (ISA) 0x0000019E (414)	Microsoft ACPI-Compliant System
 (ISA) 0x0000019F (415)	Microsoft ACPI-Compliant System
 (ISA) 0x000001A0 (416)	Microsoft ACPI-Compliant System
 (ISA) 0x000001A1 (417)	Microsoft ACPI-Compliant System
 (ISA) 0x000001A2 (418)	Microsoft ACPI-Compliant System
 (ISA) 0x000001A3 (419)	Microsoft ACPI-Compliant System
 (ISA) 0x000001A4 (420)	Microsoft ACPI-Compliant System
 (ISA) 0x000001A5 (421)	Microsoft ACPI-Compliant System
 (ISA) 0x000001A6 (422)	Microsoft ACPI-Compliant System
 (ISA) 0x000001A7 (423)	Microsoft ACPI-Compliant System
 (ISA) 0x000001A8 (424)	Microsoft ACPI-Compliant System
 (ISA) 0x000001A9 (425)	Microsoft ACPI-Compliant System
 (ISA) 0x000001AA (426)	Microsoft ACPI-Compliant System
 (ISA) 0x000001AB (427)	Microsoft ACPI-Compliant System
 (ISA) 0x000001AC (428)	Microsoft ACPI-Compliant System
 (ISA) 0x000001AD (429)	Microsoft ACPI-Compliant System
 (ISA) 0x000001AE (430)	Microsoft ACPI-Compliant System
 (ISA) 0x000001AF (431)	Microsoft ACPI-Compliant System

 (ISA) 0x000001B0 (432)	Microsoft ACPI-Compliant System
 (ISA) 0x000001B1 (433)	Microsoft ACPI-Compliant System
 (ISA) 0x000001B2 (434)	Microsoft ACPI-Compliant System
 (ISA) 0x000001B3 (435)	Microsoft ACPI-Compliant System
 (ISA) 0x000001B4 (436)	Microsoft ACPI-Compliant System
 (ISA) 0x000001B5 (437)	Microsoft ACPI-Compliant System
 (ISA) 0x000001B6 (438)	Microsoft ACPI-Compliant System
 (ISA) 0x000001B7 (439)	Microsoft ACPI-Compliant System
 (ISA) 0x000001B8 (440)	Microsoft ACPI-Compliant System
 (ISA) 0x000001B9 (441)	Microsoft ACPI-Compliant System
 (ISA) 0x000001BA (442)	Microsoft ACPI-Compliant System
 (ISA) 0x000001BB (443)	Microsoft ACPI-Compliant System
 (ISA) 0x000001BC (444)	Microsoft ACPI-Compliant System
 (ISA) 0x000001BD (445)	Microsoft ACPI-Compliant System
 (ISA) 0x000001BE (446)	Microsoft ACPI-Compliant System
 (ISA) 0x000001BF (447)	Microsoft ACPI-Compliant System
 (ISA) 0x000001C0 (448)	Microsoft ACPI-Compliant System
 (ISA) 0x000001C1 (449)	Microsoft ACPI-Compliant System
 (ISA) 0x000001C2 (450)	Microsoft ACPI-Compliant System
 (ISA) 0x000001C3 (451)	Microsoft ACPI-Compliant System
 (ISA) 0x000001C4 (452)	Microsoft ACPI-Compliant System
 (ISA) 0x000001C5 (453)	Microsoft ACPI-Compliant System
 (ISA) 0x000001C6 (454)	Microsoft ACPI-Compliant System
 (ISA) 0x000001C7 (455)	Microsoft ACPI-Compliant System
 (ISA) 0x000001C8 (456)	Microsoft ACPI-Compliant System
 (ISA) 0x000001C9 (457)	Microsoft ACPI-Compliant System
 (ISA) 0x000001CA (458)	Microsoft ACPI-Compliant System
 (ISA) 0x000001CB (459)	Microsoft ACPI-Compliant System
 (ISA) 0x000001CC (460)	Microsoft ACPI-Compliant System
 (ISA) 0x000001CD (461)	Microsoft ACPI-Compliant System
 (ISA) 0x000001CE (462)	Microsoft ACPI-Compliant System
 (ISA) 0x000001CF (463)	Microsoft ACPI-Compliant System
 (ISA) 0x000001D0 (464)	Microsoft ACPI-Compliant System
 (ISA) 0x000001D1 (465)	Microsoft ACPI-Compliant System
 (ISA) 0x000001D2 (466)	Microsoft ACPI-Compliant System
 (ISA) 0x000001D3 (467)	Microsoft ACPI-Compliant System
 (ISA) 0x000001D4 (468)	Microsoft ACPI-Compliant System
 (ISA) 0x000001D5 (469)	Microsoft ACPI-Compliant System
 (ISA) 0x000001D6 (470)	Microsoft ACPI-Compliant System
 (ISA) 0x000001D7 (471)	Microsoft ACPI-Compliant System
 (ISA) 0x000001D8 (472)	Microsoft ACPI-Compliant System
 (ISA) 0x000001D9 (473)	Microsoft ACPI-Compliant System
 (ISA) 0x000001DA (474)	Microsoft ACPI-Compliant System
 (ISA) 0x000001DB (475)	Microsoft ACPI-Compliant System
 (ISA) 0x000001DC (476)	Microsoft ACPI-Compliant System
 (ISA) 0x000001DD (477)	Microsoft ACPI-Compliant System
 (ISA) 0x000001DE (478)	Microsoft ACPI-Compliant System
(ISA) 0x000001DF (479)	Microsoft ACPI-Compliant System

	(ISA) 0x000001E0 (480)	Microsoft ACPI-Compliant System
	(ISA) 0x000001E1 (481)	Microsoft ACPI-Compliant System
	(ISA) 0x000001E2 (482)	Microsoft ACPI-Compliant System
	(ISA) 0x000001E3 (483)	Microsoft ACPI-Compliant System
	(ISA) 0x000001E4 (484)	Microsoft ACPI-Compliant System
	(ISA) 0x000001E5 (485)	Microsoft ACPI-Compliant System
	(ISA) 0x000001E6 (486)	Microsoft ACPI-Compliant System
	(ISA) 0x000001E7 (487)	Microsoft ACPI-Compliant System
	(ISA) 0x000001E8 (488)	Microsoft ACPI-Compliant System
	(ISA) 0x000001E9 (489)	Microsoft ACPI-Compliant System
	(ISA) 0x000001EA (490)	Microsoft ACPI-Compliant System
	(ISA) 0x000001EB (491)	Microsoft ACPI-Compliant System
	(ISA) 0x000001EC (492)	Microsoft ACPI-Compliant System
	(ISA) 0x000001ED (493)	Microsoft ACPI-Compliant System
	(ISA) 0x000001EE (494)	Microsoft ACPI-Compliant System
	(ISA) 0x000001EF (495)	Microsoft ACPI-Compliant System
	(ISA) 0x000001F0 (496)	Microsoft ACPI-Compliant System
	(ISA) 0x000001F1 (497)	Microsoft ACPI-Compliant System
	(ISA) 0x000001F2 (498)	Microsoft ACPI-Compliant System
	(ISA) 0x000001F3 (499)	Microsoft ACPI-Compliant System
	(ISA) 0x000001F4 (500)	Microsoft ACPI-Compliant System
	(ISA) 0x000001F5 (501)	Microsoft ACPI-Compliant System
	(ISA) 0x000001F6 (502)	Microsoft ACPI-Compliant System
	(ISA) 0x000001F7 (503)	Microsoft ACPI-Compliant System
	(ISA) 0x000001F8 (504)	Microsoft ACPI-Compliant System
	(ISA) 0x000001F9 (505)	Microsoft ACPI-Compliant System
	(ISA) 0x000001FA (506)	Microsoft ACPI-Compliant System
	(ISA) 0x000001FB (507)	Microsoft ACPI-Compliant System
	(ISA) 0x000001FC (508)	Microsoft ACPI-Compliant System
	(ISA) 0x000001FD (509)	Microsoft ACPI-Compliant System
	(ISA) 0x000001FE (510)	Microsoft ACPI-Compliant System
	(ISA) 0x000001FF (511)	Microsoft ACPI-Compliant System
	(PCI) 0x00000010 (16)	High Definition Audio Controller
	(PCI) 0x00000013 (19)	Intel(R) Active Management Technology - SOL (COM5)
	(PCI) 0xFFFFFFFFE8 (-24)	Intel(R) I211 Gigabit Network Connection
	(PCI) 0xFFFFFFFFE9 (-23)	Intel(R) Management Engine Interface
	(PCI) 0xFFFFFFFFEA (-22)	Intel(R) UHD Graphics 630
	(PCI) 0xFFFFFFFFEB (-21)	Intel(R) I211 Gigabit Network: Connection
	(PCI) 0xFFFFFFFFEC (-20)	Intel(R) I211 Gigabit Network Connection
	(PCI) 0xFFFFFFFFED (-19)	Intel(R) I211 Gigabit Network Connection
	(PCI) 0xFFFFFFFFEE (-18)	Intel(R) I211 Gigabit Network Connection
	(PCI) 0xFFFFFFFFEF (-17)	Intel(R) I211 Gigabit Network Connection
	(PCI) 0xFFFFFFFFF0 (-16)	Intel(R) I211 Gigabit Network Connection
	(PCI) 0xFFFFFFFFF1 (-15)	Intel(R) I211 Gigabit Network Connection
	(PCI) 0xFFFFFFFFF2 (-14)	Intel(R) I211 Gigabit Network Connection #2
	(PCI) 0xFFFFFFFFF3 (-13)	Intel(R) PCI Express Root Port #7 - A33E
	(PCI) 0xFFFFFFFFF4 (-12)	Intel(R) I211 Gigabit Network Connection #2
	(PCI) 0xFFFFFFFFF5 (-11)	Intel(R) I211 Gigabit Network Connection #2

-  (PCI) 0xFFFFFFFF6 (-10) Intel(R) I211 Gigabit Network Connection #2
-  (PCI) 0xFFFFFFFF7 (-9) Intel(R) I211 Gigabit Network Connection #2
-  (PCI) 0xFFFFFFFF8 (-8) Intel(R) I211 Gigabit Network Connection #2
-  (PCI) 0xFFFFFFFF9 (-7) Intel(R) I211 Gigabit Network Connection #2
-  (PCI) 0xFFFFFFFFFA (-6) Intel(R) I211 Gigabit Network Connection #2
-  (PCI) 0xFFFFFFFFB (-5) Intel(R) USB 3.1 eXtensible Host Controller - 1.10 (Microsoft)
-  (PCI) 0xFFFFFFFFC (-4) Intel(R) 300 Series Chipset Family SATA AHCI Controller
-  (PCI) 0xFFFFFFFFD (-3) Intel(R) Ethernet Connection (7) I219-LM
-  (PCI) 0xFFFFFFFFE (-2) Intel(R) PCI Express Root Port #8 - A33F

>  Memory

B.3 Memory Address Map

Memory
[0000000000A0000 - 0000000000BFFFF] PCI Express Root Complex
[0000000040000000 - 00000000403FFFF] Motherboard resources
[0000000090000000 - 0000000099FFFFFF] Intel(R) UHD Graphics 630
[0000000099000000 - 00000000DFFFFFF] PCI Express Root Complex
[00000000A0000000 - 00000000A0FFFFFF] Intel(R) UHD Graphics 630
[00000000A1100000 - 00000000A11FFFF] Intel(R) I211 Gigabit Network Connection
[00000000A1100000 - 00000000A11FFFF] Intel(R) PCI Express Root Port #8 - A33F
[00000000A1120000 - 00000000A1123FFF] Intel(R) I211 Gigabit Network Connection
[00000000A1200000 - 00000000A121FFFF] Intel(R) I211 Gigabit Network Connection #2
[00000000A1200000 - 00000000A12FFFF] Intel(R) PCI Express Root Port #7 - A33E
[00000000A1220000 - 00000000A1223FFF] Intel(R) I211 Gigabit Network Connection #2
[00000000A1320000 - 00000000A132FFFF] Intel(R) USB 3.1 eXtensible Host Controller - 1.10 (Microsoft)
[00000000A1334000 - 00000000A1335FFF] Intel(R) 300 Series Chipset Family SATA AHCI Controller
[00000000A1338000 - 00000000A13380FF] Intel(R) SMBus - A323
[00000000A1339000 - 00000000A13397FF] Intel(R) 300 Series Chipset Family SATA AHCI Controller
[00000000A133A000 - 00000000A133A0FF] Intel(R) 300 Series Chipset Family SATA AHCI Controller
[00000000E0000000 - 00000000EFFFFFF] Motherboard resources
[00000000FC800000 - 00000000FE7FFFF] PCI Express Root Complex
[00000000FD000000 - 00000000FD69FFF] Motherboard resources
[00000000FD6A0000 - 00000000FD6AFFFF] Intel(R) Serial IO GPIO Host Controller - INT3450
[00000000FD6B0000 - 00000000FD6BFFFF] Intel(R) Serial IO GPIO Host Controller - INT3450
[00000000FD6C0000 - 00000000FD6CFFFF] Motherboard resources
[00000000FD6D0000 - 00000000FD6DFFFF] Intel(R) Serial IO GPIO Host Controller - INT3450
[00000000FD6E0000 - 00000000FD6EFFFF] Intel(R) Serial IO GPIO Host Controller - INT3450
[00000000FD6F0000 - 00000000FD6FFFF] Motherboard resources
[00000000FE000000 - 00000000FE01FFFF] Motherboard resources
[00000000FE010000 - 00000000FE010FFF] Intel(R) SPI (flash) Controller - A324
[00000000FE0C0000 - 00000000FE0DFFF] Intel(R) Ethernet Connection (7) I219-LM
[00000000FE0FA000 - 00000000FE0FAFFF] Intel(R) Active Management Technology - SOL (COM5)
[00000000FE0FB000 - 00000000FE0FBFFF] Intel(R) Management Engine Interface
[00000000FE0FC000 - 00000000FE0FFFF] High Definition Audio Controller
[00000000FE100000 - 00000000FE11FFFF] High Definition Audio Controller
[00000000FE200000 - 00000000FE27FFFF] Motherboard resources
[00000000FED00000 - 00000000FED003FF] High precision event timer
[00000000FED10000 - 00000000FED17FFF] Motherboard resources
[00000000FED18000 - 00000000FED18FFF] Motherboard resources
[00000000FED19000 - 00000000FED19FFF] Motherboard resources
[00000000FED20000 - 00000000FED3FFFF] Motherboard resources
[00000000FED40000 - 00000000FED44FFF] Trusted Platform Module 2.0
[00000000FED45000 - 00000000FED8FFFF] Motherboard resources
[00000000FED90000 - 00000000FED93FFF] Motherboard resources
[00000000FEE00000 - 00000000FEEFFFFFF] Motherboard resources
[00000000FF000000 - 00000000FFFFFFFF] Motherboard resources

Appendix C

Digital I/O Ports

C.1 DIO Introduction

This section details the specifications and information needed to setup and program the Digital I/O ports for your system (DIO).

Please refer to the Linux Driver User Guide to access DIO, Watchdog Timer and Hardware Manager. The User Guide is available to download from the Drivers section of the product page.

C.2 Electrical Specifications for Digital I/O Ports

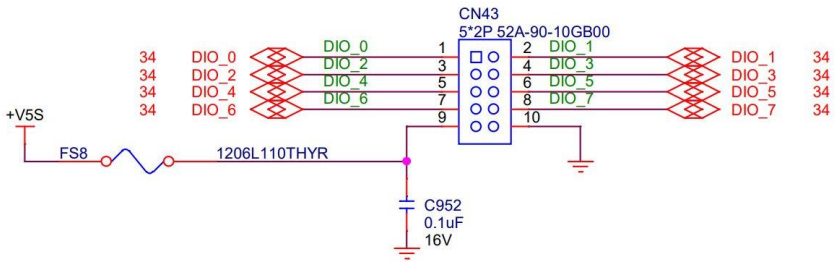

GPIO70	DIO_0
GPIO71	DIO_1
GPIO72	DIO_2
GPIO73	DIO_3
GPIO74	DIO_4
GPIO75	DIO_5
GPIO76	DIO_6
GPIO77	DIO_7

C.3 DIO Programming

BOXER-8332AI utilizes FINTEK F81966 chipset as its Digital I/O controller. The following sections detail the procedures to complete its configuration.

There are three steps to complete the configuration setup:

- Step 1** Enter MB PnP Mode.
- Step 2** Modify the data in the configuration registers.
- Step 3** Exit MB PnP Mode. Undesired results may occur if MB PnP Mode is not exited properly.

C.4 Digital I/O Register

Table 1: SuperIO relative register table

	Default Value	Note
Index	0x2E(Note1)	SIO MB PnP Mode Index Register 0x2E or 0x4E
Data	0x2F(Note2)	SIO MB PnP Mode Data Register 0x2F or 0x4F

Table 2: Digital Input relative register table

	LDN	Register	BitNum	Value	Note
DIO-1 Pin Status	0x06(Note3)	0x82(Note4)	0(Note5)		GPIO70
DIO-2 Pin Status	0x06(Note6)	0x82(Note7)	1(Note8)		GPIO71
DIO-3 Pin Status	0x06(Note9)	0x82(Note10)	2(Note11)		GPIO72
DIO-4 Pin Status	0x06(Note12)	0x82(Note13)	3(Note14)		GPIO73
DIO-5 Pin Status	0x06(Note15)	0x82(Note16)	4(Note17)		GPIO74
DIO-6 Pin Status	0x06(Note18)	0x82(Note19)	5(Note20)		GPIO75
DIO-7 Pin Status	0x06(Note21)	0x82(Note22)	6(Note23)		GPIO76
DIO-8 Pin Status	0x06(Note24)	0x82(Note25)	7(Note26)		GPIO77

Table 3: Digital Output relative register table

	LDN	Register	BitNum	Value	Note
DIO-1 Output Data	0x06(Note27)	0x81(Note28)	0(Note29)	(Note30)	GPIO70
DIO-2 Output Data	0x06(Note31)	0x81(Note32)	1(Note33)	(Note34)	GPIO71
DIO-3 Output Data	0x06(Note35)	0x81(Note36)	2(Note37)	(Note38)	GPIO72
DIO-4 Output Data	0x06(Note39)	0x81(Note40)	3(Note41)	(Note42)	GPIO73
DIO-5 Output Data	0x06(Note43)	0x81(Note44)	4(Note45)	(Note46)	GPIO74
DIO-6 Output Data	0x06(Note47)	0x81(Note48)	5(Note49)	(Note50)	GPIO75
DIO-7 Output Data	0x06(Note51)	0x81(Note52)	6(Note53)	(Note54)	GPIO76
DIO-8 Output Data	0x06(Note55)	0x81(Note56)	7(Note57)	(Note58)	GPIO77

C.5 Digital I/O Sample Program

```
*****
// SuperIO relative definition (Please reference to Table 1)
#define byte SIOIndex //This parameter is represented from Note1
#define byte SIOData //This parameter is represented from Note2
#define void IOWriteByte(byte IOPort, byte Value);
#define byte IOReadByte(byte IOPort);
// Digital Input Status relative definition (Please reference to Table 2)
#define byte DInput1LDN // This parameter is represented from Note3
#define byte DInput1Reg // This parameter is represented from Note4
#define byte DInput1Bit // This parameter is represented from Note5
#define byte DInput2LDN // This parameter is represented from Note6
#define byte DInput2Reg // This parameter is represented from Note7
#define byte DInput2Bit // This parameter is represented from Note8
#define byte DInput3LDN // This parameter is represented from Note9
#define byte DInput3Reg // This parameter is represented from Note10
#define byte DInput3Bit // This parameter is represented from Note11
#define byte DInput4LDN // This parameter is represented from Note12
#define byte DInput4Reg // This parameter is represented from Note13
#define byte DInput4Bit // This parameter is represented from Note14
#define byte DInput5LDN // This parameter is represented from Note15
#define byte DInput5Reg // This parameter is represented from Note16
#define byte DInput5Bit // This parameter is represented from Note17
#define byte DInput6LDN // This parameter is represented from Note18
#define byte DInput6Reg // This parameter is represented from Note19
#define byte DInput6Bit // This parameter is represented from Note20
#define byte DInput7LDN // This parameter is represented from Note21
#define byte DInput7Reg // This parameter is represented from Note22
#define byte DInput7Bit // This parameter is represented from Note23
#define byte DInput8LDN // This parameter is represented from Note24
#define byte DInput8Reg // This parameter is represented from Note25
#define byte DInput8Bit // This parameter is represented from Note26
*****
```

```

*****
// Digital Output control relative definition (Please reference to Table 3)
#define byte DOutput1LDN // This parameter is represented from Note27
#define byte DOutput1Reg // This parameter is represented from Note28
#define byte DOutput1Bit // This parameter is represented from Note29
#define byte DOutput1Val // This parameter is represented from Note30
#define byte DOutput2LDN // This parameter is represented from Note31
#define byte DOutput2Reg // This parameter is represented from Note32
#define byte DOutput2Bit // This parameter is represented from Note33
#define byte DOutput2Val // This parameter is represented from Note34
#define byte DOutput3LDN // This parameter is represented from Note35
#define byte DOutput3Reg // This parameter is represented from Note36
#define byte DOutput3Bit // This parameter is represented from Note37
#define byte DOutput3Val // This parameter is represented from Note38
#define byte DOutput4LDN // This parameter is represented from Note39
#define byte DOutput4Reg // This parameter is represented from Note40
#define byte DOutput4Bit // This parameter is represented from Note41
#define byte DOutput4Val // This parameter is represented from Note42
#define byte DOutput5LDN // This parameter is represented from Note43
#define byte DOutput5Reg // This parameter is represented from Note44
#define byte DOutput5Bit // This parameter is represented from Note45
#define byte DOutput5Val // This parameter is represented from Note46
#define byte DOutput6LDN // This parameter is represented from Note47
#define byte DOutput6Reg // This parameter is represented from Note48
#define byte DOutput6Bit // This parameter is represented from Note49
#define byte DOutput6Val // This parameter is represented from Note50
#define byte DOutput7LDN // This parameter is represented from Note51
#define byte DOutput7Reg // This parameter is represented from Note52
#define byte DOutput7Bit // This parameter is represented from Note53
#define byte DOutput7Val // This parameter is represented from Note54
#define byte DOutput8LDN // This parameter is represented from Note55
#define byte DOutput8Reg // This parameter is represented from Note56
#define byte DOutput8Bit // This parameter is represented from Note57
#define byte DOutput8Val // This parameter is represented from Note58
*****

```



```
*****
VOID  Main(){
    Boolean PinStatus ;

    // Procedure : AaeonReadPinStatus
    // Input :
    //   Example, Read Digital I/O Pin 3 status
    // Output :
    //   InputStatus :
    //       0: Digital I/O Pin level is low
    //       1: Digital I/O Pin level is High
    PinStatus = AaeonReadPinStatus(DInput3LDN, DInput3Reg, DInput3Bit);

    // Procedure : AaeonSetOutputLevel
    // Input :
    //   Example, Set Digital I/O Pin 6 level
    AaeonSetOutputLevel(DOutput6LDN, DOutput6Reg, DOutput6Bit,
DOutput6Val);
}
*****
```

```
*****
Boolean  AaeonReadPinStatus(byte LDN, byte Register, byte BitNum){
    Boolean PinStatus ;

    PinStatus = SIOBitRead(LDN, Register, BitNum);
    Return PinStatus ;
}
VOID  AaeonSetOutputLevel(byte LDN, byte Register, byte BitNum, byte Value){
    ConfigToOutputMode(LDN, Register, BitNum);
    SIOBitSet(LDN, Register, BitNum, Value);
}
*****
```

```

*****
VOID  SIOEnterMBPnPMode(){
    IOWriteByte(SIOIndex, 0x87);
    IOWriteByte(SIOIndex, 0x87);
}

VOID  SIOExitMBPnPMode(){
    IOWriteByte(SIOIndex, 0xAA);
}

VOID  SIOSelectLDN(byte LDN){
    IOWriteByte(SIOIndex, 0x07); // SIO LDN Register Offset = 0x07
    IOWriteByte(SIOData, LDN);
}

VOID  SIOBitSet(byte LDN, byte Register, byte BitNum, byte Value){
    Byte TmpValue;

    SIOEnterMBPnPMode();
    SIOSelectLDN(byte LDN);
    IOWriteByte(SIOIndex, Register);
    TmpValue = IOReadByte(SIOData);
    TmpValue &= ~(1 << BitNum);
    TmpValue |= (Value << BitNum);
    IOWriteByte(SIOData, TmpValue);
    SIOExitMBPnPMode();
}

VOID  SIOByteSet(byte LDN, byte Register, byte Value){
    SIOEnterMBPnPMode();
    SIOSelectLDN(LDN);
    IOWriteByte(SIOIndex, Register);
    IOWriteByte(SIOData, Value);
    SIOExitMBPnPMode();
}
*****

```

```

*****
Boolean  SIOBitRead(byte LDN, byte Register, byte BitNum){
    Byte TmpValue;

    SIOEnterMBPnPMode();
    SIOSelectLDN(LDN);
    IOWriteByte(SIOIndex, Register);
    TmpValue = IOReadByte(SIOData);
    TmpValue &= (1 << BitNum);
    SIOExitMBPnPMode();
    If(TmpValue == 0)
        Return 0;
    Return 1;
}

VOID  ConfigToOutputMode(byte LDN, byte Register, byte BitNum){
    Byte TmpValue, OutputEnableReg;

    OutputEnableReg = Register-1;
    SIOEnterMBPnPMode();
    SIOSelectLDN(LDN);
    IOWriteByte(SIOIndex, OutputEnableReg);
    TmpValue = IOReadByte(SIOData);
    TmpValue |= (1 << BitNum);
    IOWriteByte(SIOData, OutputEnableReg);
    SIOExitMBPnPMode();
}
*****

```

Appendix D

Glue Removal Procedure

D.1 Removing Glue from Your System

To protect components from damage and ensure proper operation out of the box, glue may have been applied to some cables or connectors to keep them in place during shipping. This glue must be removed before attempting to swap components or perform maintenance. This section details the steps needed to remove the glue.

Before performing any kind of system maintenance, ensure the system is shut down (not in sleep or hibernate mode) and the power cable has been removed. Follow steps in Chapter 2 to access the components inside.

You will need the following items for this step:

- Cotton or cotton swab
- Anti-static tweezers
- An alcohol solution that is at least 99.5% alcohol (ethanol solution or denatured alcohol). AAEON recommends using an eye dropper or a bottle with a nozzle as in the picture below:



Step 1: Using an eyedropper or bottle as shown above, apply a few drops of alcohol to the glue.

Step 2: Allow the alcohol to soak for 10 seconds, then use a cotton swab or cotton with anti-static tweezers to evenly rub the alcohol over the glue.

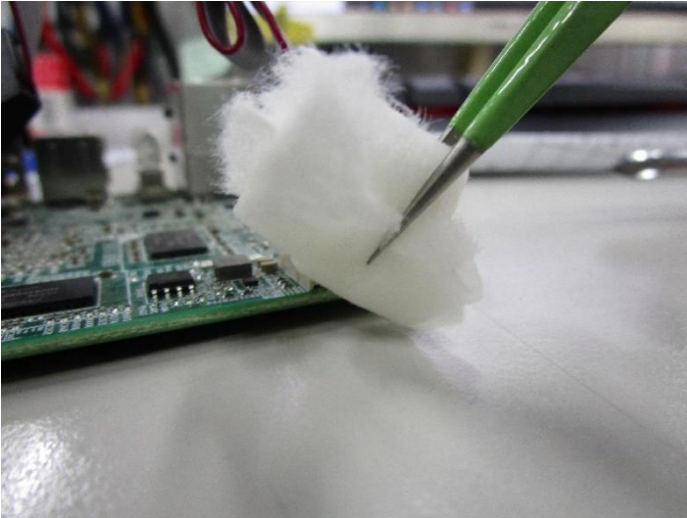

Step 3: Let soak for 10 more seconds, then use anti-static tweezers to remove the glue.

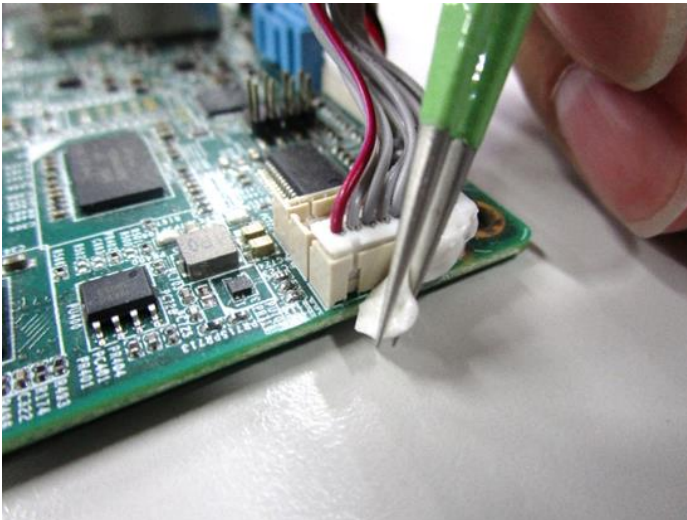

If you encounter any issues or need support, please contact your AAEON representative or visit our [Support Page](#) at AAEON.com