

BOXER-8240AI

Compact Fanless Embedded AI@Edge Box PC
with NVIDIA[®] Jetson AGX Xavier[™]

User's Manual 3rd Ed

Copyright Notice

This document is copyrighted, 2022. All rights are reserved. The original manufacturer reserves the right to make improvements to the products described in this manual at any time without notice.

No part of this manual may be reproduced, copied, translated, or transmitted in any form or by any means without the prior written permission of the original manufacturer. Information provided in this manual is intended to be accurate and reliable. However, the original manufacturer assumes no responsibility for its use, or for any infringements upon the rights of third parties that may result from its use.

The material in this document is for product information only and is subject to change without notice. While reasonable efforts have been made in the preparation of this document to assure its accuracy, AAEMON assumes no liabilities resulting from errors or omissions in this document, or from the use of the information contained herein.

AAEMON reserves the right to make changes in the product design without notice to its users.

Acknowledgements

All other products' name or trademarks are properties of their respective owners.

- NVIDIA®, the NVIDIA logo, Jetson™, Jetson Xavier™, and Jetson AGX Xavier™ are trademarks of the NVIDIA Corporation
- ITE is a trademark of Integrated Technology Express, Inc.
- IBM and VGA are trademarks of International Business Machines Corporation.
- Ubuntu is a registered trademark of Canonical.

All other product names or trademarks are properties of their respective owners. No ownership is implied or assumed for products, names or trademarks not herein listed by the publisher of this document.

Packing List

Before setting up your product, please make sure the following items have been shipped:

Item	Quantity
● BOXER-8240AI	1

If any of these items are missing or damaged, please contact your distributor or sales representative immediately.

About this Document

This User's Manual contains all the essential information, such as detailed descriptions and explanations on the product's hardware and software features (if any), its specifications, dimensions, jumper/connector settings/definitions, and driver installation instructions (if any), to facilitate users in setting up their product.

Users may refer to the product page at AAEON.com for the latest version of this document.

Safety Precautions

Please read the following safety instructions carefully. It is advised that you keep this manual for future references

1. All cautions and warnings on the device should be noted.
2. All cables and adapters supplied by AAEON are certified and in accordance with the material safety laws and regulations of the country of sale. Do not use any cables or adapters not supplied by AAEON to prevent system malfunction or fires.
3. Make sure the power source matches the power rating of the device.
4. Position the power cord so that people cannot step on it. Do not place anything over the power cord.
5. Always completely disconnect the power before working on the system's hardware.
6. No connections should be made when the system is powered as a sudden rush of power may damage sensitive electronic components.
7. If the device is not to be used for a long time, disconnect it from the power supply to avoid damage by transient over-voltage.
8. Always disconnect this device from any AC supply before cleaning.
9. While cleaning, use a damp cloth instead of liquid or spray detergents.
10. Make sure the device is installed near a power outlet and is easily accessible.
11. Keep this device away from humidity.
12. Place the device on a solid surface during installation to prevent falls
13. Do not cover the openings on the device to ensure optimal heat dissipation.
14. Watch out for high temperatures when the system is running.
15. Do not touch the heat sink or heat spreader when the system is running
16. Never pour any liquid into the openings. This could cause fire or electric shock.

17. As most electronic components are sensitive to static electrical charge, be sure to ground yourself to prevent static charge when installing the internal components. Use a grounding wrist strap and contain all electronic components in any static-shielded containers.
18. If any of the following situations arises, please the contact our service personnel:
 - i. Damaged power cord or plug
 - ii. Liquid intrusion to the device
 - iii. Exposure to moisture
 - iv. Device is not working as expected or in a manner as described in this manual
 - v. The device is dropped or damaged
 - vi. Any obvious signs of damage displayed on the device
19. **DO NOT LEAVE THIS DEVICE IN AN UNCONTROLLED ENVIRONMENT WITH TEMPERATURES BEYOND THE DEVICE'S PERMITTED STORAGE TEMPERATURES (SEE CHAPTER 1) TO PREVENT DAMAGE.**

FCC Statement

Warning!



This device complies with Part 15 FCC Rules. Operation is subject to the following two conditions: (1) this device may not cause harmful interference, and (2) this device must accept any interference received including interference that may cause undesired operation.

Caution:

There is a danger of explosion if the battery is incorrectly replaced. Replace only with the same or equivalent type recommended by the manufacturer. Dispose of used batteries according to the manufacturer's instructions and your local government's recycling or disposal directives.

Attention:

Il y a un risque d'explosion si la batterie est remplacée de façon incorrecte. Ne la remplacer qu'avec le même modèle ou équivalent recommandé par le constructeur. Recycler les batteries usées en accord avec les instructions du fabricant et les directives gouvernementales de recyclage.

产品中有毒有害物质或元素名称及含量

AAEON System

QO4-381 Rev.A0

部件名称	有毒有害物质或元素					
	铅 (Pb)	汞 (Hg)	镉 (Cd)	六价铬 (Cr(VI))	多溴联苯 (PBB)	多溴二苯 醚(PBDE)
印刷电路板 及其电子组件	×	○	○	○	○	○
外部信号 连接器及线材	×	○	○	○	○	○
外壳	○	○	○	○	○	○
中央处理器 与内存	×	○	○	○	○	○
硬盘	×	○	○	○	○	○
液晶模块	×	×	○	○	○	○
光驱	×	○	○	○	○	○
触控模块	×	○	○	○	○	○
电源	×	○	○	○	○	○
电池	×	○	○	○	○	○

本表格依据 SJ/T 11364 的规定编制。

○：表示该有毒有害物质在该部件所有均质材料中的含量均在 GB/T 26572 标准规定的限量要求以下。

×：表示该有害物质的某一均质材料超出了 GB/T 26572 的限量要求，然而该部件仍符合欧盟指令 2011/65/EU 的规范。

备注：

- 一、此产品所标示之环保使用期限，系指在一般正常使用状况下。
- 二、上述部件物质中央处理器、内存、硬盘、光驱、电源为选购品。
- 三、上述部件物质液晶模块、触控模块仅一体机产品适用。

Hazardous and Toxic Materials List

AAEON System

QO4-381 Rev.A0

Component Name	Hazardous or Toxic Materials or Elements					
	Lead (Pb)	Mercury (Hg)	Cadmium (Cd)	Hexavalent Chromium (Cr(VI))	Polybrominated biphenyls (PBBS)	Polybrominated diphenyl ethers (PBDES)
PCB and Components	X	O	O	O	O	O
Wires & Connectors for Ext.Connections	X	O	O	O	O	O
Chassis	O	O	O	O	O	O
CPU & RAM	X	O	O	O	O	O
HDD Drive	X	O	O	O	O	O
LCD Module	X	X	O	O	O	O
Optical Drive	X	O	O	O	O	O
Touch Control Module	X	O	O	O	O	O
PSU	X	O	O	O	O	O
Battery	X	O	O	O	O	O

This form is prepared in compliance with the provisions of SJ/T 11364.
 O: The level of toxic or hazardous materials present in this component and its parts is below the limit specified by GB/T 26572.

X: The level of toxic of hazardous materials present in the component exceed the limits specified by GB/T 26572, but is still in compliance with EU Directive 2011/65/EU (RoHS 2).

Notes:

1. The Environment Friendly Use Period indicated by labelling on this product is applicable only to use under normal conditions.
2. Individual components including the CPU, RAM/memory, HDD, optical drive, and PSU are optional.
3. LCD Module and Touch Control Module only applies to certain products which feature these components.

Table of Contents

Chapter 1 - Product Specifications	1
1.1 Specifications	2
1.2 Product Notice	4
Chapter 2 – Hardware Information	5
2.1 Dimensions	6
2.2 Jumpers and Connectors.....	8
2.3 List of Jumpers	10
2.3.1 Setting Jumpers	10
2.3.2 AT/ATX Mode Select (CN16 Pins 5-6).....	11
2.4 List of Connectors.....	12
2.4.1 COM1 Connector (CN1)	13
2.4.2 UART Debug Connector (CN3)	14
2.4.3 PoE Gigabit LAN Connector (CN4/CN5/CN6/CN7)	15
2.4.4 JTAG Debug Connector (CN11).....	15
2.4.5 M.2 2230 E-Key Slot (CN12)	16
2.4.6 40 Pin Header (CN13).....	17
2.4.7 RTC Battery Connector (CN14).....	17
2.4.8 Front Panel Connector (CN16).....	18
2.4.9 Audio Connector (CN19)	19
2.4.10 DP Connector (CN22)	19
2.4.11 HDMI Connector (CN23).....	20
2.4.12 USB 3.2 + USB 2.0 Combo Connector (CN24).....	21
2.4.13 DC-In Power Connector (CN26)	21
2.4.14 USB 3.0 Type C Connector (CN27/CN28).....	22
2.4.15 Micro USB (Flash & OTG) (CN29).....	23
2.4.16 M.2 2280 M-Key Slot (CN30).....	24

2.4.17	SATA Connector with Power (CN31)	25
2.4.18	COM5 Header (CN32).....	26
2.4.19	CANBus Connector (CN33).....	27
2.4.20	MicroSD Connector (CN34)	28
2.4.21	RS-232/422/485 Select (SW4, SW5)	29
2.5	Hardware Assembly	30
Chapter 3 – OS Flash Guide		32
3.1	Before Installation.....	33
3.2	Connecting to PC/Force Recovery Mode	34
3.3	Flash Image to Board.....	35
Chapter 4 – ACLinux User Guide		36
4.1	Introduction	37
4.2	ACLinux Updates	38
4.3	ACLinux Ubuntu Compatibility	38
4.4	Known Issues	39
4.5	Power Mode Control for BOXER-8420AI	40

Chapter 1

Product Specifications

1.1 Specifications

System

AI Accelerator	NVIDIA® Jetson AGX Xavier™
CPU	8-core ARM v8.2 64bit CPU, 8MB L2 + 4MB L3
System Memory	32GB 256-Bit LPDDR4x 137GB/s
Storage Device	32GB eMMC M.2 M-Key 2280 x 1 (PCIe[x4]) microSD slot x 1 2.5" SATA drive bay x 1
Display Interface	HDMI 2.0 x 1 Display Port 1.4 x 1
Ethernet	10/100/1000 Base-TX x 1 IEEE 802.3af PoE LAN x 4
I/O	RJ-45 x 4 for PoE (802.3af, total 60W) USB Type-C x 2 for USB 3.2 Gen 1 USB Type-A x 1 for USB 3.2 Gen 1 USB Type-A x 1 for USB 2.0 Audio Mic-in x 1 Audio Line-out x 1 HDMI Type A for HDMI v2.0 x 1 Display Port 1.4 x 1 DB-9 x 1 for RS-232/422/485 (set by switch) CANBUS x 1 microSD card slot x 1 2-pin terminal block for 12~24V power input Power ON/OFF switch x 1 Recovery x 1 Reset x 1

System

	40-pin header compliance with NVIDIA Dev Kit 40 pins (4 pins CANBUS occupied)
Expansion	USB 2.0 header x 1 (Optional, circuit reserved) M.2 E-Key 2230 x 1 for Wi-Fi/Bluetooth (PCIe[x1] + USB) M.2 M-Key 2280 x 1 (PCIe[x4]) JTAG Connector
Indicator	Power LED x 1
OS Support	Linux (NVIDIA Jetpack 4.5 and above) Linux (AAEON ACLinux 4.9)

Power Supply

Power Requirement	12 ~ 24V DC with 2-pin terminal block
--------------------------	---------------------------------------

Mechanical

Mounting	Wall-mount kit (default)
Dimensions (W x D x H)	8.26" x 6.45" x 2.32" (210mm x 164mm x 59mm)
Gross Weight	6 lb. (2.72 kg)
Net Weight	4.23 lb. (1.92 kg)

Environmental

Operating Temperature	14°F ~ 131°F (-10°C ~ 55°C, according to IEC60068-2 with 0.5 m/s air flow)
Storage Temperature	-4°F ~ 158°F (-40°C ~ 70°C)
Storage Humidity	95% at 40°C, non-condensing
Anti-Vibration	3 Grms/ 5 ~ 500Hz/ operation – MicroSD or eMMC
Certification	CE/FCC class A

1.2 Product Notice

Micro-USB: Micro-USB port is for flashing image only.

USB ports: USB ports do not support USB DVD ROM because of file system.

USB 3.2 Gen 1: USB 3.2 Gen 1 is the current name for 5Gbps specification, formerly USB 3.0.

LAN Indicator Behavior

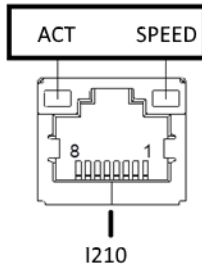

Chapter 2

Hardware Information

2.1 Dimensions

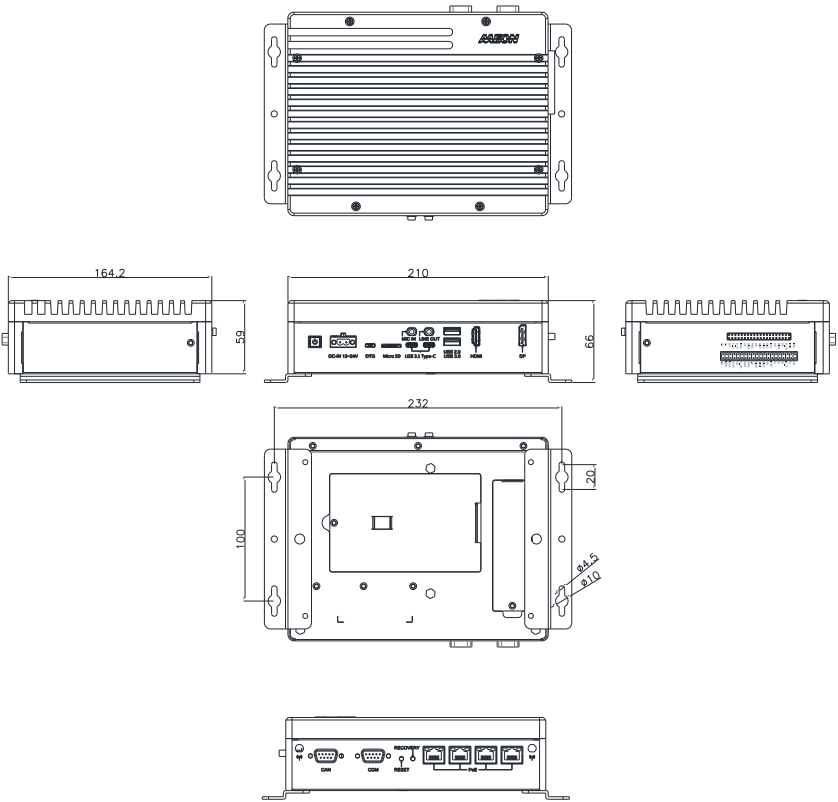

System I/O Layout

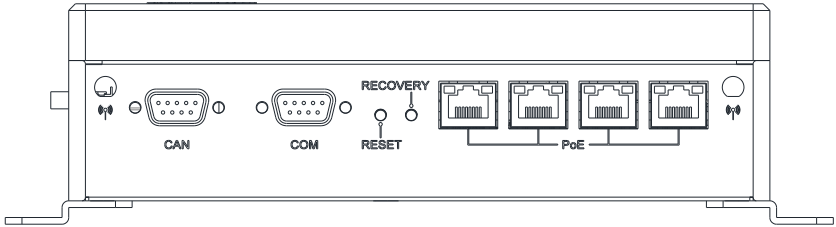
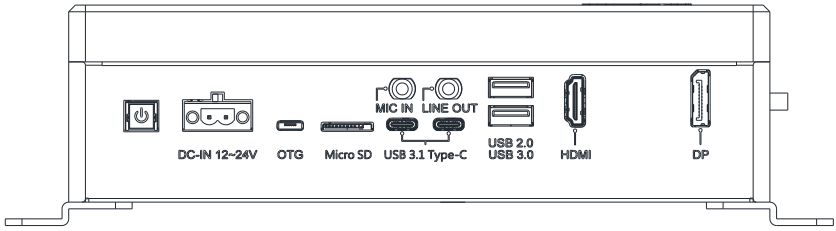
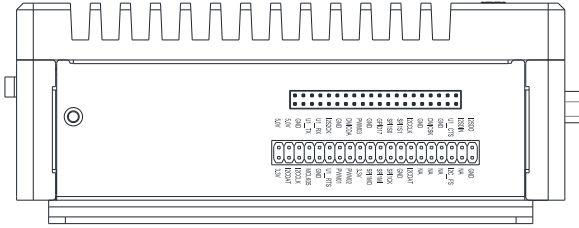

2.2 Jumpers and Connectors

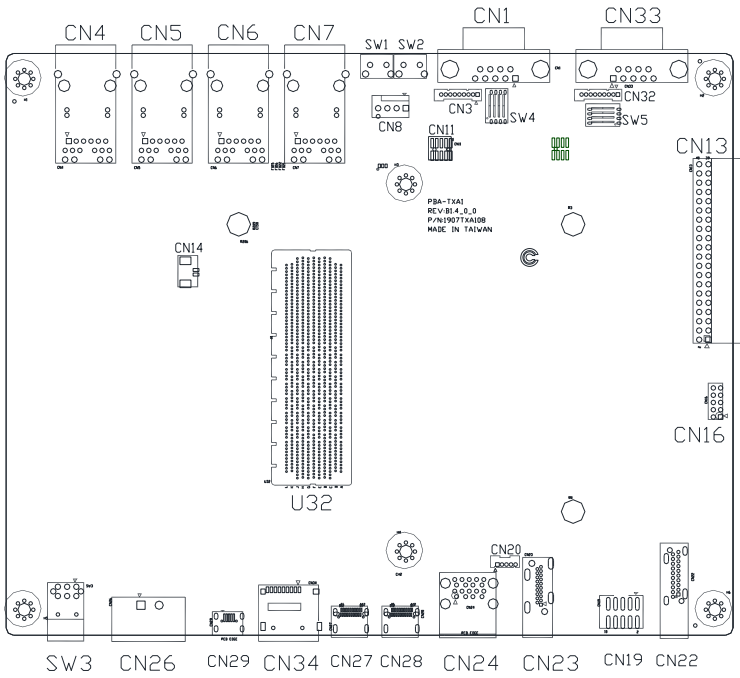

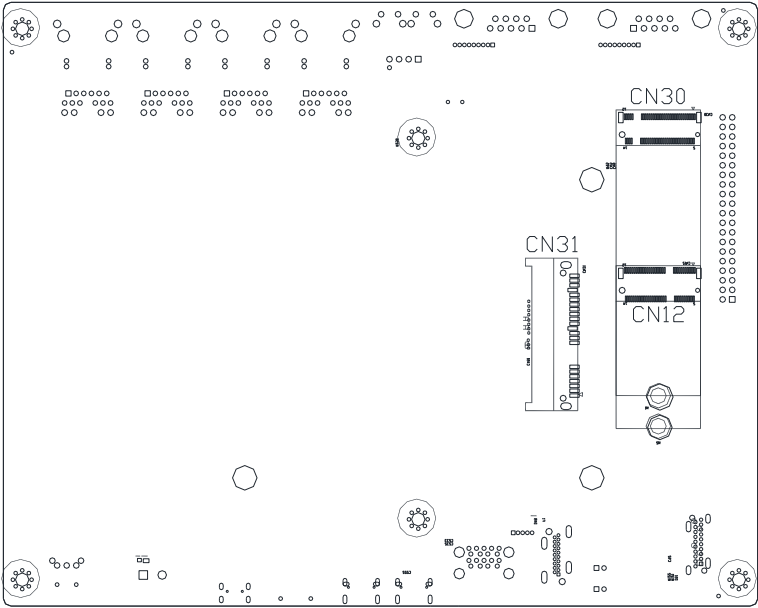

2.3 List of Jumpers

The board has a number of jumpers that allow you to configure your system to suit your application.

The table below shows the function of each of the board's jumpers

Label	Function
CN16 (Pins 5-6)	AT/ATX mode select

2.3.1 Setting Jumpers

You can configure your system to match the needs of your application by setting jumpers. A jumper is the simplest kind of electric switch. It consists of two metal pins and a small metal clip (often protected by a plastic cover) that slides over the pins to connect them. To “close” a jumper you connect the pins with the clip.

To “open” a jumper you remove the clip. Sometimes a jumper will have three pins, labeled 1, 2 and 3. In this case you would connect either pins 1 and 2 or 2 and 3.

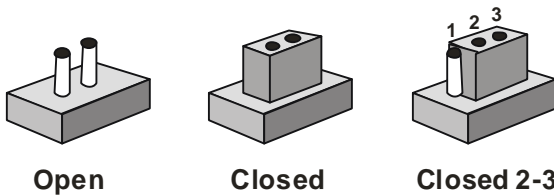

A pair of needle-nose pliers may be helpful when working with jumpers.

If you have any questions about the best hardware configuration for your application, contact your local distributor or sales representative before you make any changes.

Generally, you simply need a standard cable to make most connections.

2.3.2 AT/ATX Mode Select (CN16 Pins 5-6)

The AT/ATX Mode Select functions by connecting pins 5 and 6 of CN16. To prevent damage to the system, do not connect pins 5 and 6 to any other pin.

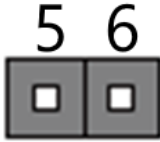

Open – ATX Mode
(Default)

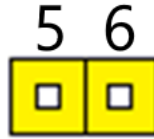

Closed – AT Mode

CN16 pins 5-6	Function
5-6 Open	ATX Power Mode (Default) – Auto Power Disabled
5-6 Closed	AT Power Mode – Auto Power Enabled

2.4 List of Connectors

The board has a number of connectors that allow you to configure your system to suit your application.

The table below shows the function of each of the board's connectors

Label	Function
CN1	COM1 Connector (/dev/ttyTHS1)
CN3	UART3 for Debug
CN4	PoE Gigabit LAN Connector (PHY)
CN5	PoE Gigabit LAN Connector (i210)
CN6	PoE Gigabit LAN Connector (i210)
CN7	PoE Gigabit LAN Connector (i210)
CN11	JTAG Debug Connector
CN12	M.2 2230 E-Key Slot
CN13	40-Pin Header
CN14	RTC Battery Connector
CN16	Front Panel Connector
CN19	Audio Connector
CN20	Internal USB 2.0 Connector
CN22	DP Connector
CN23	HDMI Connector
CN24	USB 3.2 + USB 2.0 Combo Connector
CN26	DC-IN Power Connector
CN27	USB 3.2 Type-C Connector (w/o DP)
CN28	USB 3.2 Type-C Connector (w/o DP)
CN29	Micro USB (Flash & OTG)
CN30	M.2 2280 M-Key Slot
CN31	SATA Connector with Power

Label	Function
CN32	COM5 Header (/dev/ttyTHS5)
CN33	CAN BUS Connector
CN34	MicroSD Connector
SW1	Recovery Switch
SW2	Reset Switch
SW3	Power Switch
SW4	RS-232/422/485 Select (/dev/ttyTHS1)
SW5	RS-232/422/485 Select (/dev/ttyTHS5)
U32	Jetson AGX Xavier CPU Connector

2.4.1 COM1 Connector (CN1)

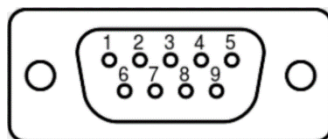

Pin	RS-232	RS-422	RS-485
1	-	TX-	RA-
2	RXD	TX+	RA+
3	TXD	RX+	-
4	-	RX-	-
5	GND	-	-
6	-	-	-
7	-	-	-
8	-	-	-
9	-	-	-

2.4.2 UART Debug Connector (CN3)

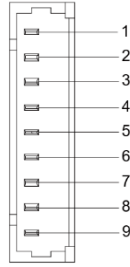

Pin	Pin Name	Signal Type
1	UART3 TXD	TTL
2	UART3 RXD	TTL
3	-	-
4	-	-
5	RXD_3	RS-232
6	TXD_3	RS-232
7	I2C SCL	3.3V
8	I2C SDA	3.3V
9	GND	-

2.4.3 PoE Gigabit LAN Connector (CN4/CN5/CN6/CN7)

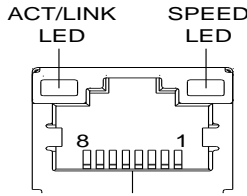

Pin	Signal	Pin	Signal
1	MDI0+	2	MDI0-
3	MDI1+	4	MDI1-
5	MDI2+	6	MDI2-
7	MDI3+	8	MDI3-

2.4.4 JTAG Debug Connector (CN11)

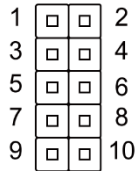

Pin	Signal	Pin	Signal
1	+1.8V	2	JTAG_TMS
3	GND	4	JTAG_TCK
5	GND	6	JTAG_TDO
7	GND	8	JTAG_TDI
9	10K PULL-UP 1.8V	10	SYS_RST#

2.4.5 M.2 2230 E-Key Slot (CN12)

		GND	75
74	3.3V	RESERVED/REFCLKn1	73
72	3.3V	RESERVED/REFCLKp1	71
70	UIM_POWER_SRC/GPIO1/PEWAKE1#	GND	69
68	UIM_POWER_SNK/CLKREQ1#	RESERVED/PETn1	67
66	UIM_SWP/PERST1#	RESERVED/PETp1	65
64	RESERVED	GND	63
62	ALERT# (O)(0/3.3V)	RESERVED/PERn1	61
60	I2C_CLK (I)(0/3.3V)	RESERVED/PERp1	59
58	I2C_DATA (I/O)(0/3.3V)	GND	57
56	W_DISABLE1# (I)(0/3.3V)	PEWAKE0# (I/O)(0/3.3V)	55
54	W_DISABLE2# (I)(0/3.3V)	CLKREQ0# (I/O)(0/3.3V)	53
52	PERST0# (I)(0/3.3V)	GND	51
50	SUSCLK(32kHz) (I)(0/3.3V)	REFCLKn0	49
48	COEX1 (I/O)(0/1.8V)	REFCLKp0	47
46	COEX2(I/O)(0/1.8V)	GND	45
44	COEX3(I/O)(0/1.8V)	PETn0	43
42	VENDOR DEFINED	PETp0	41
40	VENDOR DEFINED	GND	39
38	VENDOR DEFINED	PERn0	37
36	UART CTS (I)(0/1.8V)	PERp0	35
34	UART RTS (O)(0/1.8V)	GND	33
32	UART RXD (I)(0/1.8V)	Module Key	
	Module Key	Module Key	
	Module Key	Module Key	
	Module Key	Module Key	
	Module Key	Module Key	
22	UART TXD (O)(0/1.8V)	SDIO RESET# (I)(0/1.8V)	23
20	UART WAKE# (O)(0/3.3V)	SDIO WAKE# (O)(0/1.8V)	21
18	GND	SDIO DATA3(I/O)(0/1.8V)	19
16	LED2# (O)(OD)	SDIO DATA2(I/O)(0/1.8V)	17
14	PCM_IN/125 SD_IN (I)(0/1.8V)	SDIO DATA1(I/O)(0/1.8V)	15
12	PCM_OUT/125 SD_OUT (O)(0/1.8V)	SDIO DATA0(I/O)(0/1.8V)	13
10	PCM_SYNC/125 WS (I/O)(0/1.8V)	SDIO CMD(I/O)(0/1.8V)	11
8	PCM_CLK/125 SCK (I/O)(0/1.8V)	SDIO CLK(I)(0/1.8V)	9
6	LED1# (O)(OD)	GND	7
4	3.3V	USB_D-	5
2	3.3V	USB_D+	3
		GND	1

2.4.6 40 Pin Header (CN13)

3.3V	1		2	5.0V
I2C_GP5_DAT	3		4	5.0V
I2C_GP5_CLK	5		6	GND
MCLK05	7		8	UART1_TX
GND	9		10	UART1_RX
UART1_RTS	11		12	I2S2_CLK
PWM01	13		14	GND
GPIO27_PWM2	15		16	GPIO8_AO_DMIC_IN_DAT
3.3V	17		18	GPIO35_PWM3
SPI1_MOSI	19		20	GND
SPI1_MISO	21		22	GPIO17_40HEADER
SPI1_SCK	23		24	SPI1_CS0
GND	25		26	SPI1_CS1
I2C_GP2_DAT	27		28	I2C_GP2_CLK
CAN0_DIN	29		30	GND
CAN0_DOUT	31		32	GPIO9_CAN1_GPIO0_DMIC_CLK
CAN1_DOUT	33		34	GND
I2S_FS	35		36	UART1_CTS
CAN1_DIN	37		38	I2S_SDIN
GND	39		40	I2S_SDOUT

Note: Pins 29, 31, 33, 37 used by CAN BUS Connector (CN33).

2.4.7 RTC Battery Connector (CN14)

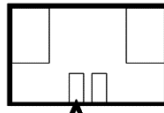

Pin	Signal	Pin	Signal
1	+3V	2	GND

2.4.8 Front Panel Connector (CN16)

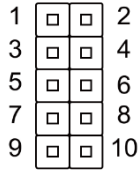

Pin	Signal	Pin	Signal
1	GND	2	Recovery
3	Reset	4	Power Button
5	GND (see note)	6	GND (see note)
7	CVB_STBY	8	System_OC#
9	+3.3V_AO	10	+5V_AO

Note: Pin 5 and 6 are used for setting AT/ATX Power Mode. See **Chapter 2.3.2** for information. To prevent damage to your system, do not connect Pins 5 and 6 with any other pin.

2.4.9 Audio Connector (CN19)

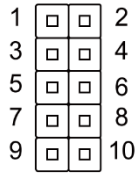

Pin	Signal	Pin	Signal
1	MIC1	2	GND
3	MIC2	4	GPIO4
5	HPO_R	6	MIC_IN_DET
7	GND	8	-
9	HPO_L	10	GPIO3

GPIO3: Headphone or Jack detection.

GPIO4: Pre-sense – detects if audio dongle is connected to header.

2.4.10 DP Connector (CN22)

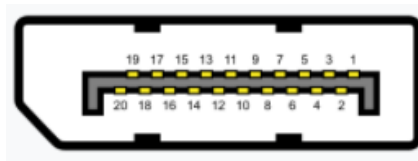

Pin	Signal	Pin	Signal
1	ML_Lane0_P	2	GND
3	ML_Lane0_N	4	ML_Lane1_P
5	GND	6	ML_Lane1_N
7	ML_Lane2_P	8	GND
9	ML_Lane2_N	10	ML_Lane3_P

Pin	Signal	Pin	Signal
11	GND	12	ML_Lane3_N
13	NC	14	NC
15	AUX_CH_P	16	GND
17	AUX_CH_N	18	DP_HDP
19	GND	20	DP_POWER(3.3V)

2.4.11 HDMI Connector (CN23)

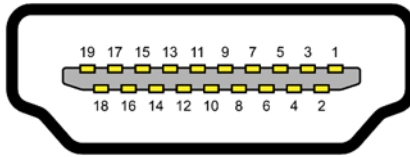

Pin	Signal	Pin	Signal
1	HDMI_DATA2_P	2	GND
3	HDMI_DATA2_N	4	HDMI_DATA1_P
5	GND	6	HDMI_DATA1_N
7	HDMI_DATA0_P	8	GND
9	HDMI_DATA0_N	10	HDMI_CLK_P
11	GND	12	HDMI_CLK_N
13	NC	14	NC
15	HDMI_SCL	16	HDMI_SDA
17	GND	18	HDMI_PWR
19	HDMI_HDP	-	-

2.4.12 USB 3.2 + USB 2.0 Combo Connector (CN24)

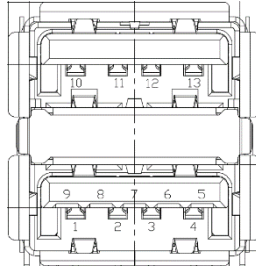

Pin	Signal	Pin	Signal
USB 3.2 (Bottom)		USB 2.0 (Top)	
U1	VBUS_1	U10	VBUS_2
U2	(A)D-	U11	(B)D-
U3	(A)D+	U12	(B)D+
U4	GND	U13	GND
U5	(A)SSRX-	-	-
U6	(A)SSRX+	-	-
U7	GND	-	-
U8	(A)SSTX-	-	-
U9	(A)SSTX+	-	-

2.4.13 DC-In Power Connector (CN26)

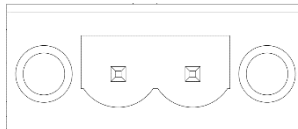

Pin	Signal	Pin	Signal
1	PWR_IN	2	GND

2.4.14 USB 3.0 Type C Connector (CN27/CN28)

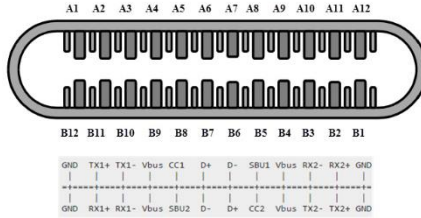

Pin	Signal	Pin	Signal
A1	GND	B12	GND
A2	(A)SSTX+	B11	(B)SSRX+
A3	(A)SSTX-	B10	(B)SSRX-
A4	VBUS_1	B9	VBUS_2
A5	CC1	B8	SBU2
A6	(A)D+	B7	(B)D-
A7	(A)D-	B6	(B)D+
A8	SBU1	B5	CC2
A9	VBUS_1	B4	VBUS_2
A10	(A)SSRX-	B3	(B)SSTX-
A11	(A)SSRX+	B2	(B)SSTX+
A12	GND	B1	GND

2.4.15 Micro USB (Flash & OTG) (CN29)

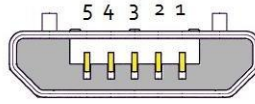

USB Micro-B

Pin	Signal	Pin	Signal
1	+5V	2	USB1-
3	USB1+	4	ID
5	GND	-	-

2.4.16 M.2 2280 M-Key Slot (CN30)

		GND	75
74	3.3V	GND	73
72	3.3V	GND	71
70	3.3V	PEDET (NC-PCIe/GND-SATA)	69
68	SUSCLK[32kHz] (O)(Q/3.3V)	N/C	67
	Connector Key	Connector Key	
	Connector Key	Connector Key	
	Connector Key	Connector Key	
	Connector Key	Connector Key	
58	N/C	GND	57
56	N/C	REFCLKp	55
54	PEWAKE# (I/O)(Q/3.3V) or N/C	REFCLKn	53
52	CLKREQ# (I/O)(Q/3.3V) or N/C	GND	51
50	PERST# (O)(Q/3.3V) or N/C	PETp0/SATA-A+	49
48	N/C	PETn0/SATA-A-	47
46	N/C	GND	45
44	N/C	PERp0/SATA-B-	43
42	N/C	PERn0/SATA-B+	41
40	N/C	GND	39
38	DEVSIP (O)	PETp1	37
36	N/C	PETn1	35
34	N/C	GND	33
32	N/C	PERp1	31
30	N/C	PERn1	29
28	N/C	GND	27
26	N/C	PETp2	25
24	N/C	PETn2	23
22	N/C	GND	21
20	N/C	PERp2	19
18	3.3V	PERn2	17
16	3.3V	GND	15
14	3.3V	PETp3	13
12	3.3V	PETn3	11
10	DAS/DSS# (I/O)/LED1# (I)(Q/3.3V)	GND	9
8	N/C	PERp3	7
6	N/C	PERn3	5
4	3.3V	GND	3
2	3.3V	GND	1

2.4.17 SATA Connector with Power (CN31)

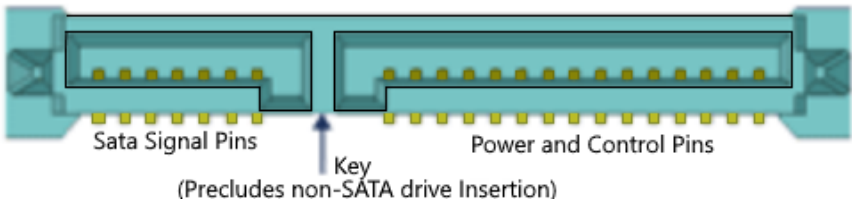

Pin	Signal	Pin	Signal
SATA Signal		SATA Power and Control	
1	GND	1	NC
2	TX+	2	NC
3	TX-	3	NC
4	GND	4	GND
5	RX+	5	GND
6	RX-	6	GND
7	GND	7	+5V
-	-	8	+5V
-	-	9	+5V
-	-	10	GND
-	-	11	NC
-	-	12	GND
-	-	13	NC
-	-	14	NC
-	-	15	NC

2.4.18 COM5 Header (CN32)

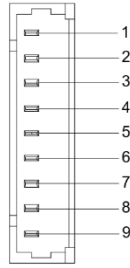

Pin	RS-232	RS-422	RS-485
1	-	TX-	RA-
2	-	-	-
3	RXD	TX+	RA+
4	-	-	-
5	TXD	RX+	
6	-	-	-
7	-	RX-	-
8	-	-	-
9	GND	GND	GND

2.4.19 CANBus Connector (CN33)

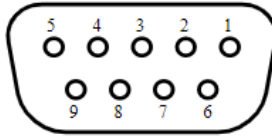

Pin	Signal	Pin	Signal
1	-	6	-
2	CAN0_H	7	CAN0_L
3	GND	8	CAN1_H
4	CAN1_L	9	+5V
5	GND	-	-

2.4.20 MicroSD Connector (CN34)

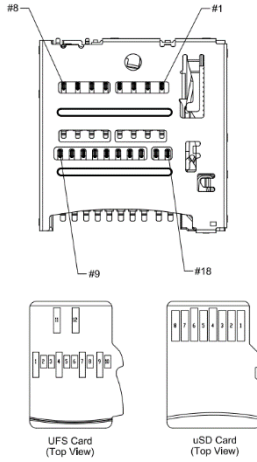

microSD Card		
Pin (Card)	Pin (Connector)	Function
1	#1	DAT2
2	#2	CD/DAT3
3	#3	CMD
4	#4	VDD
5	#5	CLK
6	#6	VSS
7	#7	DAT0
8	#8	DAT1

2.4.21 RS-232/422/485 Select (SW4, SW5)

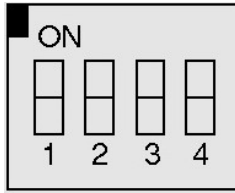

Mode	S-1	S-2	S-3	S-4
1T/1R RS-232	On	On	-	-
1T/1R RS-422	On	Off	-	-
1T/1R RS-485	Off	On	-	-
Low power shutdown	Off	Off	-	-
Enable RS-422/RS-485 bias and termination resistors.	-	-	On	-
Disable RS-422/RS-485 bias and termination resistors.	-	-	Off	-
250kbps for RS-232 and RS-485/RS-422	-	-	-	On
RS-232 to 3Mbps and RS-485/RS-422 to 20Mbps	-	-	-	Off

2.5 Hardware Assembly

The M.2 2280 M-Key slot, M.2 2230 E-Key slot, and 2.5" HDD/SSD bay can be accessed via removable covers on the bottom panel of the BOXER-8240AI system as shown in the following steps.

2.5" HDD or SSD Installation

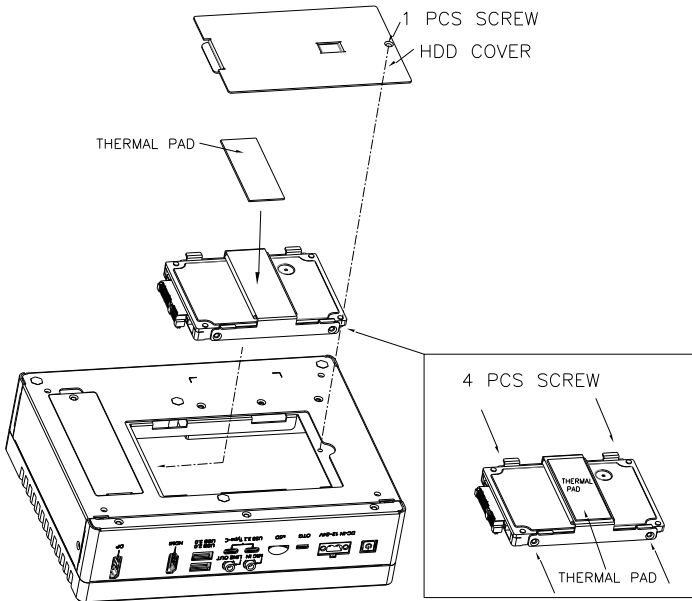

Note: To ensure proper operation, make sure to secure 2.5" drive to drive chassis with four screws.

Note: Thermal pad is used to affix SSD.

M.2 2280 M-Key / M.2 2230 E-Key Installation

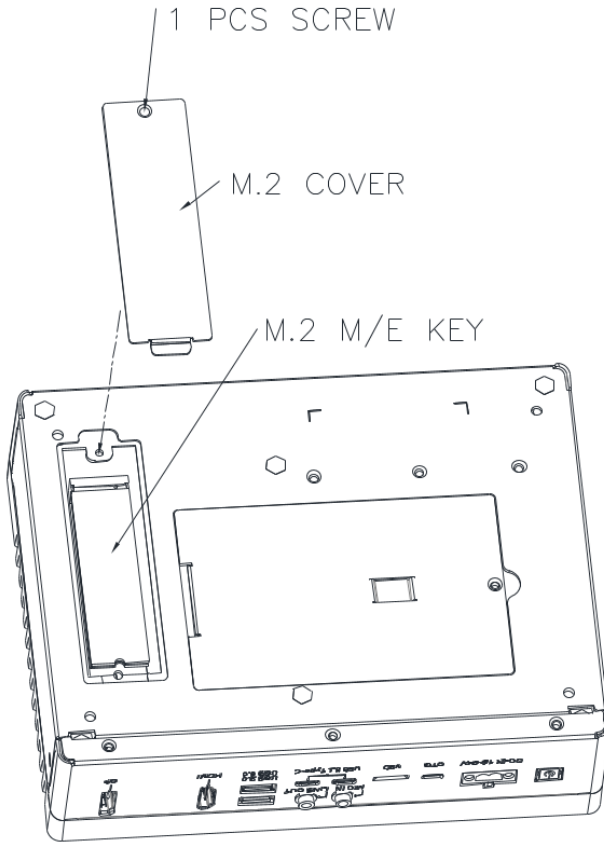

Chapter 3

OS Flash Guide

3.1 Before Installation

Before starting the process make sure your BOXER-8240AI system is turned off and the power in is disconnected. You will need a host PC running Ubuntu 16.04 or 18.04, and make sure the NVIDIA Jetson AGX Xavier module is installed onto the BOXER-8240AI carrier board/ system.

Download the compressed OS image file. The file name will follow the format of:

ACLlinux_4.9_{OS_IF}_{PLF_IF}_{PJ_IF}_{BN}.tar.gz

For example:

ACLlinux_4.9_ACLNX49D.NV04.BOXER-8240AI.2.tar.gz

Note: Filename may differ from this example.

- I. **{OS_IF}** is OS Information. For example, **ACLNX49D** means ACLinux 4.9, Desktop version.
- II. **{PLF_IF}** is Platform Information; e.g. **NV04**
- III. **{PJ_IF}** is Project Information; e.g. **BOXER-8240AI**
- IV. **{BN}** is Build Number; e.g. 0, 1, 2, etc.

3.2 Connecting to PC/Force Recovery Mode

On Host Computer, open Linux terminal and enter the following command to extract compressed OS image files (*file name may vary*):

```
$ tar -zxvf ACLinux_4.9_ACLNX49D.NV04.BOXER-8240AI.2.tar.gz
```

Next, perform the following steps to force the system to start in USB Recovery Mode:

1. Connect the Micro-USB plug on the USB cable to the Recovery Port on the BOXER-8240AI and the other end to an available USB port on the host PC.
2. Connect the BOXER-8240AI power supply.
3. Power on the system, then press and hold the recovery button. While continuing to hold the recovery button, press and hold the reset button for two seconds before releasing the reset button, then releasing the recovery button.
4. When device is in recovery mode, lsusb command on host PC will list a line of **“0955:7019 Nvidia Corp”**

Recovery mode can also be initiated with the system disassembled. Ensure the NVIDIA Jetson AGX Xavier module is installed and refer to the image below to perform the steps:

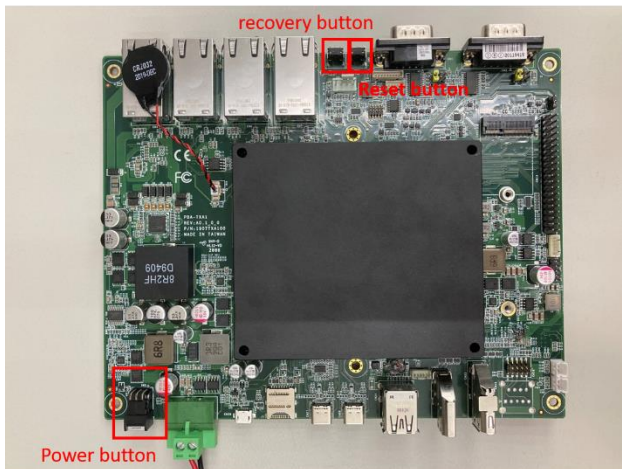

3.3 Flash Image to Board

Use the following steps to flash the OS to the BOXER-8240AI.

- 1) Open terminal on Ubuntu host PC, then access the bootloader folder you extracted in the previous section.
- 2) Enter the following BMP command in terminal to flash the image:

```
$ sudo ./flashall.sh
```

- 3) Wait as the image is installed. Once finished you should see the following:

```
[ 200.6713 ] Writing partition rce-fw_b with camera-rtcpu-rce_sigheader.img.encrypt
[ 200.6919 ] [.....] 100%
[ 200.7002 ] Writing partition adsp-fw with adsp-fw_sigheader.bin.encrypt
[ 200.7186 ] [.....] 100%
[ 200.7419 ] Writing partition adsp-fw_b with adsp-fw_sigheader.bin.encrypt
[ 200.7222 ] [.....] 100%
[ 200.7455 ] Writing partition sc7 with warmboot_t194_prod_sigheader.bin.encrypt
[ 200.7637 ] [.....] 100%
[ 200.7667 ] Writing partition sc7_b with warmboot_t194_prod_sigheader.bin.encrypt
[ 200.7853 ] [.....] 100%
[ 200.7880 ] Writing partition BMP with bmp.blob
[ 200.8069 ] [.....] 100%
[ 200.8096 ] Writing partition BMP_b with bmp.blob
[ 200.8287 ] [.....] 100%
[ 200.8316 ] Writing partition kernel with boot_sigheader.img.encrypt
[ 200.8506 ] [.....] 100%
[ 202.4330 ] Writing partition kernel_b with boot_sigheader.img.encrypt
[ 202.4468 ] [.....] 100%
[ 204.0000 ] Writing partition kernel-dtb with tegra194-p2888-0001-p2822-0000_sigheader.dtb.encrypt
[ 204.0143 ] [.....] 100%
[ 204.0216 ] Writing partition kernel-dtb_b with tegra194-p2888-0001-p2822-0000_sigheader.dtb.encrypt
[ 204.0428 ] [.....] 100%
[ 204.0691 ]
[ 204.0712 ] tegradevflash_v2 --write BCT br_bct_BR.bct
[ 204.0732 ] Bootloader version 01.00.0000
[ 204.1666 ] Writing partition BCT with br_bct_BR.bct
[ 204.1671 ] [.....] 100%
[ 204.2240 ]
[ 204.2395 ] tegradevflash_v2 --write MB1_BCT mb1_cold_boot_bct_MB1_sigheader.bct.encrypt
[ 204.2412 ] Bootloader version 01.00.0000
[ 204.3352 ] Writing partition MB1_BCT with mb1_cold_boot_bct_MB1_sigheader.bct.encrypt
[ 204.3368 ] [.....] 100%
[ 204.3552 ]
[ 204.3580 ] tegradevflash_v2 --write MB1_BCT_b mb1_cold_boot_bct_MB1_sigheader.bct.encrypt
[ 204.3601 ] Bootloader version 01.00.0000
[ 204.4544 ] Writing partition MB1_BCT_b with mb1_cold_boot_bct_MB1_sigheader.bct.encrypt
[ 204.4552 ] [.....] 100%
[ 204.4746 ]
[ 204.4878 ] tegradevflash_v2 --write MEM_BCT mem_coldboot_sigheader.bct.encrypt
[ 204.4890 ] Bootloader version 01.00.0000
[ 204.5823 ] Writing partition MEM_BCT with mem_coldboot_sigheader.bct.encrypt
[ 204.5833 ] [.....] 100%
[ 204.5998 ]
[ 204.6018 ] tegradevflash_v2 --write MEM_BCT_b mem_coldboot_sigheader.bct.encrypt
[ 204.6036 ] Bootloader version 01.00.0000
[ 204.6956 ] Writing partition MEM_BCT_b with mem_coldboot_sigheader.bct.encrypt
[ 204.6984 ] [.....] 100%
[ 204.7124 ]
[ 204.7125 ] Flashing completed

[ 204.7126 ] Coldbooting the device
[ 204.7147 ] tegrarcn_v2 --isb2
[ 204.9065 ]
[ 204.9095 ] tegradevflash_v2 --reboot coldboot
[ 204.9117 ] Bootloader version 01.00.0000
[ 205.0073 ]
```

Chapter 4

ACLinux User Guide

4.1 Introduction

ACLinux is the customized Linux operating system designed and optimized for use with AAEON systems powered by NVIDIA Jetson SoCs. ACLinux is compatible with Ubuntu and comes with the NVIDIA Jetson SDK pre-installed. For BOXER-8240AI, it also features NVIDIA Jetpack 4.4 preinstalled with the following SDK tools:

Jetpack 4.4

All built-in Jetson SDK Components:

- a. CUDA Toolkit for L4T v10.2
- b. cuDNN v8.0
- c. TensorRT v7.1
- d. OpenCV v4.1.1
- e. VisionWorks v1.6
- f. VPI v0.3.7
- g. NVIDIA Container Runtime v0.9.0
- h. Multimedia API v32.4
- i. DeepStream v5.0

Initial login for ACLinux is:

Account: aaeon

Password: aaeon



ACLinux GUI based on LXDE (left) vs Ubuntu Gnome GUI (right).

4.4 Known Issues

The storage device where the OS is installed must have at least 10 KB of free space. If there is less than 10 KB on the storage device, the OS will not be able to complete the login process, and the system will be stuck in a reboot loop.

Running **\$ sudo apt upgrade** command in terminal for NVIDIA OTA will overwrite the kernel device tree in the OS, which can lead to unexpected results including losing I/O ports. For regular updates, visit the product page at AAEON.com to get the latest ACLinux image.

4.5 Power Mode Control for BOXER-8420AI

The NVIDIA Jetson AGX Xavier supports multiple power modes to give users a range of performance options to best suit their application's needs. To change power mode, look up the Mode ID of the corresponding power mode according to the chart below. Default Mode ID is 7 (15W with max CPU freq. 2188 MHz).

NVPModel clock configuration for Jetson AGX Xavier 16GB and 32GB									
Property	Mode								
	MAXN	10W	15W	30W	30W	30W	30W	15W *	15W *
Power budget	n/a	10W	15W	30W	30W	30W	30W	30W	15W
Mode ID	0	1	2	3	4	5	6	7	
Online CPU	8	2	4	8	6	4	2	4	
CPU maximal frequency (MHz)	2265.6	1200	1200	1200	1450	1780	2100	2188	
GPU TPC	4	2	4	4	4	4	4	4	
GPU maximal frequency (MHz)	1377	520	670	900	900	900	900	670	
DLA cores	2	2	2	2	2	2	2	0	
DLA maximal frequency (MHz)	1395.2	550	750	1050	1050	1050	1050	0	
PVA cores	2	0	1	1	1	1	1	0	
PVA maximal frequency (MHz)	1088	0	550	760	760	760	760	0	
Memory maximal frequency (MHz)	2133	1066	1333	1600	1600	1600	1600	1333	
SOC clocks maximal frequency (MHz) All modes	adsp 300 ape 150 axi_cbb 408 bmp 896 bpmc_apb 408 display 800 display_hub 400		csi 400 host1x 408 isp 1190.4 nvdec 1190.4 nvinc 1075.2 nvjpg 716.8 pex 500			rce 819.2 sce 729.6 se 1036.8 tsec 1036.8 vi 998.4 vic 1036.8			

* The default mode is 15W (mode ID 7). Default mode is intended to improve desktop application performance. PVA and DLA are excluded from the 15W power budget.

Image Source NVIDIA Xavier [Online Power Management Guide](#)

Open terminal and enter the following command:

```
$ sudo nvpmode1 -m ID
```

ID refers to the Mode ID number. For power mode 0 (max power mode), you would enter:

```
$ sudo nvpmode1 -m 0
```

The system will require a reboot for the changes to take effect. To check the current power mode, enter the following command in terminal:

```
$ sudo nvpmode1 -q
```

Alternatively, the power mode can be managed and changed remotely with a third-party JTOP tool (usually requires between 200 MB and 300 MB storage space).

To install the JTOP tool, enter the following commands in terminal:

```
$ sudo apt-get install -y python3-pip
$ sudo python3 -m pip install jetson-stats
```

Once the tool is installed, it can be accessed in terminal with the command:

```
$ sudo jtop
```

Users can control the power mode with the interface.

```
NVIDIA Jetson AGX Xavier - Jetpack 4.3 [L4T 32.3.1]
CPU1 [|||||] Schedutil - 66%] 2.3GHz CPU5 [|||||] Schedutil - 7%] 2.3GHz
CPU2 [|||||] Schedutil - 9%] 2.3GHz CPU6 [|||||] Schedutil - 9%] 2.3GHz
CPU3 [|||||] Schedutil - 11%] 2.3GHz CPU7 [|||||] Schedutil - 3%] 2.2GHz
CPU4 [|||||] Schedutil - 7%] 2.3GHz CPU8 [|||||] Schedutil - 7%] 2.2GHz

MEM PG [|||||] 0%] BG [|||||] 0%]
Mem [|||||] 2.0G/15.8GB] (1fb 2997x4MB)
Swp [|||||] 0.0GB/7.9GB] (cached 0MB)
ENC [|||||] 0%] 2.1GHz

GPU [|||||] 0%] 318MHz
Dsk [|||||] 13.6GB/27.4GB]

[info] [Sensor] [Temp] [Power/mW] [Cur] [Avr]
UpT: 0 days 7:29:52 AO 51.50C CPU 1853 828
FAN [|||||] 30%] Ta= 30% AIX 54.50C CV 0 0
Jetson clocks: Stopped CPU 57.00C GPU 0 91
NV Power(0): MAXN CPU 57.50C SOC 2316 1379
APR: 150MHz Tboard 48.00C SYSSV 2974 2750
HW engine: Tdiode 53.00C VDDRO 154 163
ENC: NOT RUNNING thermal 55.55C Total 7297 5211
DEC: NOT RUNNING

! ALT - 2 GPU - 3 MEM - 4 CTRL - 5 INFO
Raffaello Bonghi
```