

BOXER-8110AI

Compact Fanless Embedded AI@Edge Box PC

User's Manual 4th Ed

Copyright Notice

This document is copyrighted, 2019. All rights are reserved. The original manufacturer reserves the right to make improvements to the products described in this manual at any time without notice.

No part of this manual may be reproduced, copied, translated, or transmitted in any form or by any means without the prior written permission of the original manufacturer. Information provided in this manual is intended to be accurate and reliable. However, the original manufacturer assumes no responsibility for its use, or for any infringements upon the rights of third parties that may result from its use.

The material in this document is for product information only and is subject to change without notice. While reasonable efforts have been made in the preparation of this document to assure its accuracy, AAEMON assumes no liabilities resulting from errors or omissions in this document, or from the use of the information contained herein.

AAEMON reserves the right to make changes in the product design without notice to its users.

Acknowledgement

All other products' name or trademarks are properties of their respective owners.

- NVIDIA, the NVIDIA logo, and Jetson are trademarks of the NVIDIA Corporation
- Microsoft Windows is a registered trademark of Microsoft Corp.
- Intel, Pentium, Celeron, and Xeon are registered trademarks of Intel Corporation
- Atom is a trademark of Intel Corporation
- ITE is a trademark of Integrated Technology Express, Inc.
- IBM and VGA are trademarks of International Business Machines Corporation.
- Ubuntu is a registered trademark of Canonical

All other product names or trademarks are properties of their respective owners.

Packing List

Before setting up your product, please make sure the following items have been shipped:

Item	Quantity
● BOXER-8110AI	1
● Wallmount Bracket	2

If any of these items are missing or damaged, please contact your distributor or sales representative immediately.

About this Document

This User's Manual contains all the essential information, such as detailed descriptions and explanations on the product's hardware and software features (if any), its specifications, dimensions, jumper/connector settings/definitions, and driver installation instructions (if any), to facilitate users in setting up their product.

Users may refer to the AAEON.com for the latest version of this document.

Safety Precautions

Please read the following safety instructions carefully. It is advised that you keep this manual for future references

1. All cautions and warnings on the device should be noted.
2. All cables and adapters supplied by AAEON are certified and in accordance with the material safety laws and regulations of the country of sale. Do not use any cables or adapters not supplied by AAEON to prevent system malfunction or fires.
3. Make sure the power source matches the power rating of the device.
4. Position the power cord so that people cannot step on it. Do not place anything over the power cord.
5. Always completely disconnect the power before working on the system's hardware.
6. No connections should be made when the system is powered as a sudden rush of power may damage sensitive electronic components.
7. If the device is not to be used for a long time, disconnect it from the power supply to avoid damage by transient over-voltage.
8. Always disconnect this device from any AC supply before cleaning.
9. While cleaning, use a damp cloth instead of liquid or spray detergents.
10. Make sure the device is installed near a power outlet and is easily accessible.
11. Keep this device away from humidity.
12. Place the device on a solid surface during installation to prevent falls
13. Do not cover the openings on the device to ensure optimal heat dissipation.
14. Watch out for high temperatures when the system is running.
15. Do not touch the heat sink or heat spreader when the system is running
16. Never pour any liquid into the openings. This could cause fire or electric shock.

17. As most electronic components are sensitive to static electrical charge, be sure to ground yourself to prevent static charge when installing the internal components. Use a grounding wrist strap and contain all electronic components in any static-shielded containers.
18. If any of the following situations arises, please the contact our service personnel:
 - i. Damaged power cord or plug
 - ii. Liquid intrusion to the device
 - iii. Exposure to moisture
 - iv. Device is not working as expected or in a manner as described in this manual
 - v. The device is dropped or damaged
 - vi. Any obvious signs of damage displayed on the device
19. **DO NOT LEAVE THIS DEVICE IN AN UNCONTROLLED ENVIRONMENT WITH TEMPERATURES BEYOND THE DEVICE'S PERMITTED STORAGE TEMPERATURES (SEE CHAPTER 1) TO PREVENT DAMAGE.**

FCC Statement

Warning!



This device complies with Part 15 FCC Rules. Operation is subject to the following two conditions: (1) this device may not cause harmful interference, and (2) this device must accept any interference received including interference that may cause undesired operation.

Caution:

There is a danger of explosion if the battery is incorrectly replaced. Replace only with the same or equivalent type recommended by the manufacturer. Dispose of used batteries according to the manufacturer's instructions and your local government's recycling or disposal directives.

Attention:

Il y a un risque d'explosion si la batterie est remplacée de façon incorrecte. Ne la remplacer qu'avec le même modèle ou équivalent recommandé par le constructeur. Recycler les batteries usées en accord avec les instructions du fabricant et les directives gouvernementales de recyclage.

China RoHS Requirements (CN)

产品中有毒有害物质或元素名称及含量

AAEON System

QO4-381 Rev.A0

部件名称	有毒有害物质或元素					
	铅 (Pb)	汞 (Hg)	镉 (Cd)	六价铬 (Cr(VI))	多溴联苯 (PBB)	多溴二苯 醚(PBDE)
印刷电路板 及其电子组件	×	○	○	○	○	○
外部信号 连接器及线材	×	○	○	○	○	○
外壳	○	○	○	○	○	○
中央处理器 与内存	×	○	○	○	○	○
硬盘	×	○	○	○	○	○
液晶模块	×	×	○	○	○	○
光驱	×	○	○	○	○	○
触控模块	×	○	○	○	○	○
电源	×	○	○	○	○	○
电池	×	○	○	○	○	○

本表格依据 SJ/T 11364 的规定编制。

○：表示该有毒有害物质在该部件所有均质材料中的含量均在 GB/T 26572 标准规定的限量要求以下。

×：表示该有害物质的某一均质材料超出了 GB/T 26572 的限量要求，然而该部件

仍符合欧盟指令 2011/65/EU 的规范。

备注：

- 一、此产品所标示之环保使用期限，系指在一般正常使用状况下。
- 二、上述部件物质中央处理器、内存、硬盘、光驱、电源为选购品。
- 三、上述部件物质液晶模块、触控模块仅一体机产品适用。

Hazardous and Toxic Materials List

AAEON System

QO4-381 Rev.A0

Component Name	Hazardous or Toxic Materials or Elements					
	Lead (Pb)	Mercury (Hg)	Cadmium (Cd)	Hexavalent Chromium (Cr(VI))	Polybrominated biphenyls (PBBs)	Polybrominated diphenyl ethers (PBDEs)
PCB and Components	X	O	O	O	O	O
Wires & Connectors for Ext.Connections	X	O	O	O	O	O
Chassis	O	O	O	O	O	O
CPU & RAM	X	O	O	O	O	O
HDD Drive	X	O	O	O	O	O
LCD Module	X	X	O	O	O	O
Optical Drive	X	O	O	O	O	O
Touch Control Module	X	O	O	O	O	O
PSU	X	O	O	O	O	O
Battery	X	O	O	O	O	O

This form is prepared in compliance with the provisions of SJ/T 11364.

O: The level of toxic or hazardous materials present in this component and its parts is below the limit specified by GB/T 26572.

X: The level of toxic of hazardous materials present in the component exceed the limits specified by GB/T 26572, but is still in compliance with EU Directive 2011/65/EU (RoHS 2).

Notes:

1. The Environment Friendly Use Period indicated by labelling on this product is applicable only to use under normal conditions.
2. Individual components including the CPU, RAM/memory, HDD, optical drive, and PSU are optional.
3. LCD Module and Touch Control Module only applies to certain products which feature these components.

Table of Contents

Chapter 1 - Product Specifications	1
1.1 Specifications	2
1.2 Product Notice	3
Chapter 2 – Hardware Information	5
2.1 Dimensions	6
2.2 Jumpers and connectors	7
2.3 List of Jumpers	8
2.3.1 Setting Jumpers	8
2.3.2 Auto Power Button (CN5)	9
2.4 List of Connectors	10
2.4.1 RTC Connector (CN6)	11
2.4.2 Micro SD (CN5)	11
2.4.3 PWM FAN connector (CN11)	11
2.4.4 USB 2.0 OTG connector (CN9)	12
2.4.5 Front Panel, UART for Debug and Exp. I/O (CN17)	12
2.4.6 TX2 Module connector (CN10)	13
2.4.7 CANBUS connector (DB9 Female)	14
2.4.8 GPIO Port Connector (CN14)	14
2.4.9 HDMI connector (CN8)	15
2.4.10 USB3.0 connector (CN7)	16
2.4.11 Power in connector (CN2)	16
2.4.12 COM port connector (Male)	17
2.4.13 LAN (RJ-45) Port	17
2.5 Wall Mount Assembly	18
Chapter 3 – OS Flash guide	19
3.1 Force USB Recovery Mode	20

3.2 Software & BSP21

Chapter 1

Product Specifications

1.1 Specifications

System

CPU	HMP Dual Denver 2 + Quad ARM A57
Chipset	—
System Memory	8GB LPDDR4
AI Solution	Nvidia Jetson TX2
Display Interface	HDMI 2.0
Storage Device	32GB eMMC 5.1, MicroSD
Ethernet	10/100/1000Base-TX x 1
I/O	USB 3.0 x 2 HDMI x 1 LAN x 1 MicroSD x 1 OTG x 1 Antenna Hole x 1 DC Power Input x 1 2 channel CANBUS x 1 DB-9 RS-232 x 1
Expansion	—
Indicator	—
OS Support	AAEON ACLinux 4.9, Compliance with Ubuntu 18.04

Power Supply

Power Requirement 12V with 2-pin terminal block

Mechanical

Mounting Wallmount

Dimensions (W x H x D) 110mm(W) x 40mm(H) x 65mm(D)

Gross Weight 2.20 lbs. (1 kg)

Net Weight 1.10 lbs. (0.5 kg)

Environmental

Operating Temperature Operating Temperature -4°F ~122°F (-20°C ~ 50°C, according to IEC60068-2 with 0.5 m/s airflow; with Industrial Device)

Storage Temperature -49°F ~176°F (-45°C ~ 80°C)

Storage Humidity 95% @ 40°C, non-condensing

Anti-Vibration 3 Grms/ 5 ~ 500Hz/ operation – eMMC

Certification CE/FCC class A

1.2 Product Notice

OTG: OTG port is ideally for flashing image only.

COM1: Support 1.8 meter length cable when baud rate 115200bps, and 15 meter cable when baud rate 9600bps.

USB ports: USB ports are not support USB DVD ROM because of file system.

Chapter 2

Hardware Information

2.1 Dimensions

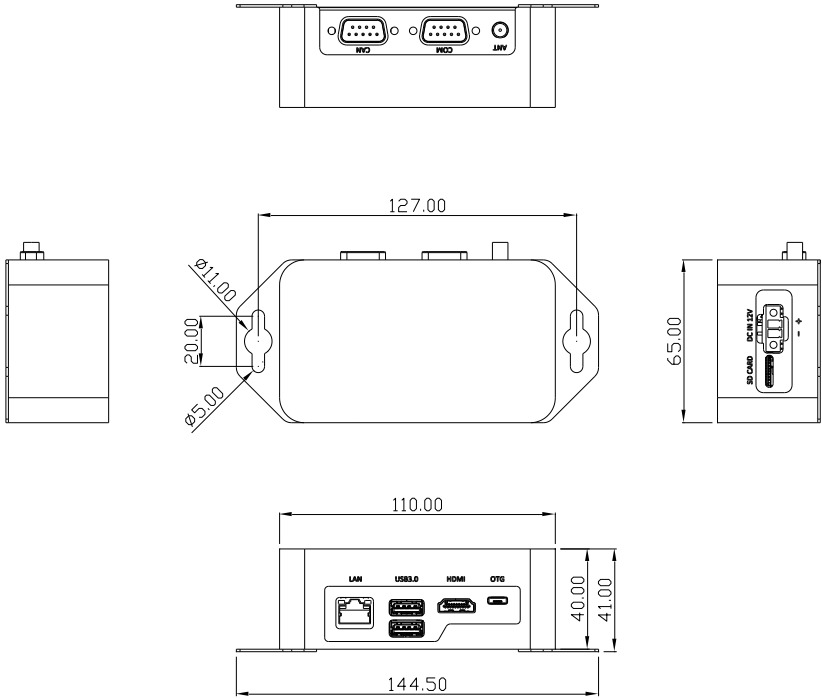

2.2 Jumpers and connectors

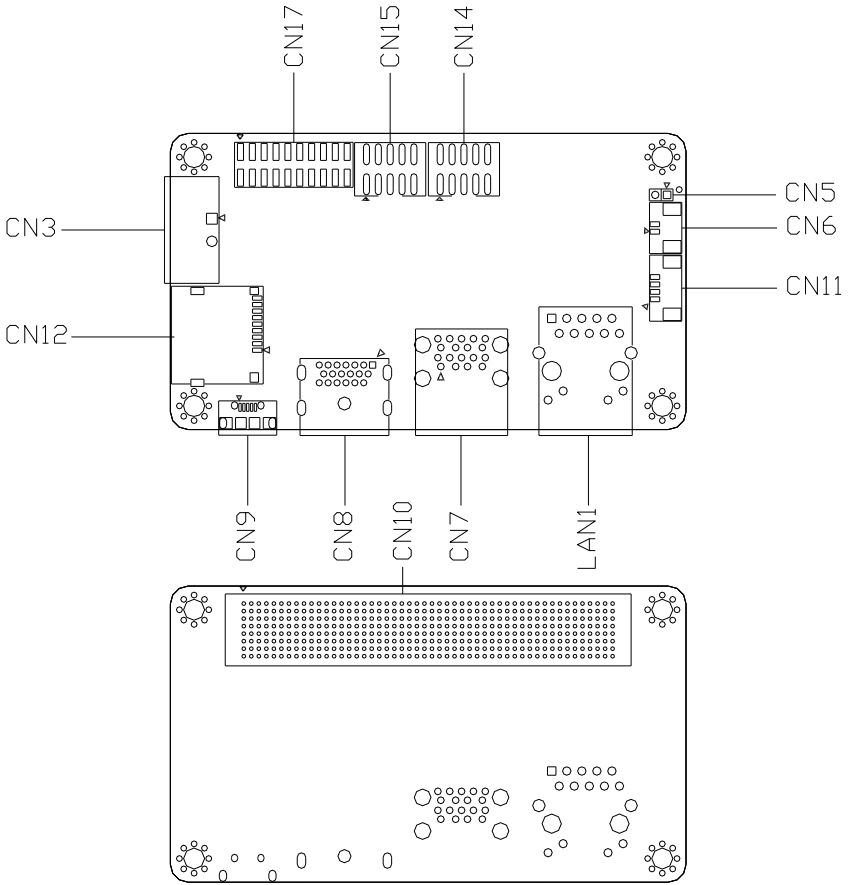

2.3 List of Jumpers

The board has a number of jumpers that allow you to configure your system to suit your application.

The table below shows the function of each of the board's jumpers

Label	Function
CN5	AT/ATX mode select

2.3.1 Setting Jumpers

You configure your card to match the needs of your application by setting jumpers. A jumper is the simplest kind of electric switch. It consists of two metal pins and a small metal clip (often protected by a plastic cover) that slides over the pins to connect them.

To “close” a jumper you connect the pins with the clip.

To “open” a jumper you remove the clip. Sometimes a jumper will have three pins, labeled 1, 2 and 3. In this case you would connect either pins 1 and 2 or 2 and 3.

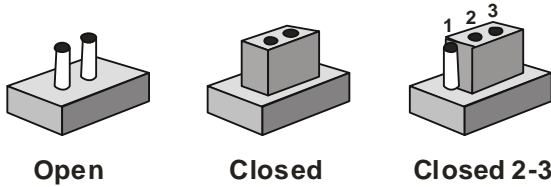

A pair of needle-nose pliers may be helpful when working with jumpers.

If you have any doubts about the best hardware configuration for your application, contact your local distributor or sales representative before you make any change.

Generally, you simply need a standard cable to make most connections.

2.3.2 Auto Power Button (CN5)



Disable(Default)



Enable

JP3	Function
1-2	Open ATX
1-2	Close AT (Default)

2.4 List of Connectors

The board has a number of connectors that allow you to configure your system to suit your application.

The table below shows the function of each of the board's connectors

Label	Function
CN6	RTC battery connector
CN11	FAN connector
CN9	USB 2.0 OTG
CN10	TX2 Module connector
CN8	HDMI connector
CN7	USB 3.0 x 2
CN3	Power In connector
CN4	COM Port
CN12	MicroSD
CN14	GPIO
CN15	CANBUS
CN17	Front Panel and Exp. I/O
LAN1	GbE LAN 1

2.4.1 RTC Connector (CN6)

Pin	Signal	Pin	Signal
1	+5V	2	GND

2.4.2 Micro SD (CN5)

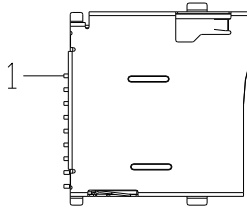

Pin	Signal	Pin	Signal
1	SDCARD D3	2	SDCARD CMD
3	GND	4	SDCARD PWR(+3.3V)
5	SDCARD CLK	6	SDCARD D0
7	SDCARD D1	8	SDCARD D2
9	SDCARD CD	10	

2.4.3 PWM FAN connector (CN11)

Pin	Signal	Pin	Signal
1	FAN PWM	2	FAN TACH
3	+5V	4	GND

2.4.4 USB 2.0 OTG connector (CN9)

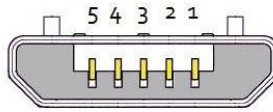

USB Micro-B

Pin	Signal	Pin	Signal
1	VBUS	2	USB1-
3	USB1+	4	ID
5	GND		

2.4.5 Front Panel, UART for Debug and Exp. I/O (CN17)

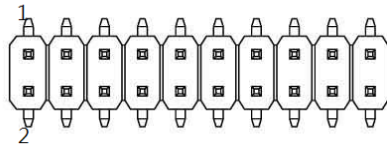

Pin	Signal	Pin	Signal
1	UART0 RX	2	COM1 RX
3	UART0 TX	4	COM1 TX
5	UART0 RTS	6	COM1 RTS
7	UART0 CTS	8	COM1 CTS
9	GND	10	GND
11	POWER BUTTON	12	GND
13	RESET	14	GND
15	RECOVERY	16	GND
17	SLEEP	18	GND
19	3.3V	20	EXT LED

2.4.6 TX2 Module connector (CN10)

	A	B	C	D	E	F	G	H
1	VDD IN	VDD IN	VDD IN	RSVD	FORCE RECOV#	AUDIO MCLK	I2S0 SDIN	I2S0 LRCLK
2	VDD IN	VDD IN	VDD IN	RSVD	SLEEP#	GPIO19 AUD_RST	I2S0 CLK	I2S0 SDOUT
3	GND	GND	GND	RSVD	SP10 CLK	SP10 CS0#	GND	GPIO20 AUD_INT
4	GND	GND	GND	RSVD	SP10 MISO	SP10 MOSI	RSVD	RSVD
5	RSVD	RSVD	RSVD	RSVD	I2S3 SDIN	I2S3 LRCLK	I2S2 CLK	I2S2 LRCLK
6	I2C PM CLK	I2C PM DAT	I2C CAM CLK	I2C CAM DAT	I2S3 CLK	I2S3 SDOUT	I2S2 SDIN	I2S2 SDOUT
7	CHARGEIN#	CARRIER STBY#	BATLOW#	GPIO5 CAM_FLASH_EN	RSVD	GPIO1 CAM1_PWR#	GPIO4 CAM_STROBE	GPIO3 CAM1_RST#
8	GPIO24_AP_WAKE_MDM	VIN_PWR_BAD#	RSVD	RSVD	RSVD	CAM1_MCLK	GPIO0_CAM0_PWR#	GPIO2_CAM0_RST#
9	GPIO17_APM2M_READY	GPIO17_MDM2M_READY	RSVD	UART1_TX	UART1_RTS#	CAM0_MCLK	UART3_CTS#	UART3_RX
10	GPIO18_MDM_WAKE_AP	GPIO18_MDM_COLDBOOT	RSVD	UART1_RX	UART1_CTS#	GND	UART3_RTS#	UART3_TX
11	RSVD	JTAG_TCK	RSVD	RSVD	RSVD	RSVD	UART0_RTS#	UART0_CTS#
12	JTAG_TMS	JTAG_TDI	RSVD	RSVD	RSVD	RSVD	UART0_RX	UART0_TX
13	JTAG_TDO	JTAG_GPO	RSVD	I2S1_LRCLK	SP11_CS1#	SP11_MOSI	SP11_CLK	GPIO8_AIS_PRIOR_INT
14	JTAG_RTCK	GND	I2S1_SDIN	I2S1_SDOUT	SP11_CS0#	SP11_MISO	GPIO9_MOTION_INT	SP12_CLK
15	UART2_CTS#	UART2_RX	I2S1_CLK	I2C_GPO_DAT	I2C_GPO_CLK	GND	SP12_MOSI	SP12_MISO
16	UART2_RTS#	UART2_TX	FAN_PWM	RSVD	RSVD	SP12_CS1#	SP12_CS0#	SDCARD_PWR_EN
17	USBO_EN_OCH	FAN_TACH	RSVD	RSVD	RSVD	SDCARD_CD#	GND	SDCARD_D1
18	USB1_EN_OCH	RSVD	RSVD	RSVD	RSVD	SDCARD_D3	SDCARD_CLK	SDCARD_D0
19	RSVD	GPIO11_AP_WAKE_BT	RSVD	RSVD	GND	SDCARD_D2	SDCARD_CMD	GND
20	I2C_GPI_DAT	GPIO10_WIFI_WAKE_AP	RSVD	GND	CS15_D1-	SDCARD_WP	GND	CS14_D1-
21	I2C_GPI_CLK	GPIO12_BT_EN	GND	CS15_CLK-	CS15_D1+	GND	CS14_CLK-	CS14_D1+
22	GPIO_EXPI_INT	GPIO13_BT_WAKE_AP	CS15_D0-	CS15_CLK+	GND	CS14_D0-	CS14_CLK+	GND
23	GPIO_EXPO_INT	GPIO7_TOUCH_RST	CS15_D0+	GND	CS13_D1-	CS14_D0+	GND	CS12_D1-
24	RSVD	TOUCH_CLK	CS13_D0+	CS13_CLK-	CS13_D1+	GND	CS12_CLK-	CS12_D1+
25	LCD_TE	GPIO6_TOUCH_INT	CS13_D0-	CS13_CLK+	GND	CS12_D0-	CS12_CLK+	GND
26	RSVD	LCD_VDD_EN	CS13_D0+	GND	CS11_D1-	CS12_D0+	GND	CS10_D1-
27	RSVD	LCD0_BKLT_PWM	GND	CS11_CLK-	CS11_D1+	GND	CS10_CLK-	CS10_D1+
28	GND	LCD_BKLT_EN	CS11_D0-	CS11_CLK+	GND	CS10_D0-	CS10_CLK+	GND
29	SDIO_RST#	SDIO_CMD	CS11_D0+	GND	DS13_D1+	CS10_D0+	GND	DS12_D1+
30	SDIO D3	SDIO_CLK	GND	RSVD	DS13_D1-	GND	DS12_CLK+	DS12_D1-
31	SDIO D2	SDIO_D0	DS13_D0+	RSVD	GND	DS12_D0+	DS12_CLK-	GND
32	SDIO D1	GND	DS13_D0-	GND	DS11_D1+	DS12_D0-	GND	DS10_D1+
33	DP1_HPD	HDMI_CEC	GND	RSVD	DS11_D1-	GND	DS10_CLK+	DS10_D1-
34	DP1_AUX_CH-	DP0_AUX_CH-	DS11_D0+	RSVD	GND	DS10_D0+	DS10_CLK-	GND
35	DP1_AUX_CH+	DP0_AUX_CH+	DS11_D0-	GND	DP1_TX3-	DS10_D0-	GND	DP0_TX3-
36	USBO_OTG_ID	DP0_HPD	GND	DP1_TX2-	DP1_TX3+	GND	DP0_TX2-	DP0_TX3+
37	GND	USBO_VBUS_DET	DP1_TX1-	DP1_TX2+	GND	DP0_TX1-	DP0_TX2+	GND
38	USB1_D+	GND	DP1_TX1+	GND	DP1_TX0-	DP0_TX1+	GND	DP0_TX0-
39	USB1_D-	USB0_D+	GND	PEX_RFU_TX+	DP1_TX0+	GND	PEX_RFU_RX+	DP0_TX0+
40	GND	USB0_D-	PEX2_TX+	PEX_RFU_TX-	GND	PEX2_RX+	PEX_RFU_RX-	GND
41	RSVD	GND	PEX2_TX-	GND	PEX1_TX+	PEX2_RX-	GND	PEX1_RX+
42	RSVD	USB2_D+	GND	USB_S51_TX+	PEX1_TX-	GND	USB_S51_RX+	PEX1_RX-
43	GND	USB2_D-	USB_S50_TX+	USB_S51_TX-	GND	USB_S50_RX+	USB_S51_RX-	GND
44	PEX0_REFCLK+	GND	USB_S50_TX-	GND	PEX0_TX+	USB_S50_RX-	GND	PEX0_RX+
45	PEX0_REFCLK-	PEX1_REFCLK+	GND	SATA_TX+	PEX0_TX-	GND	SATA_RX+	PEX0_RX-
46	RESET_OUT#	PEX1_REFCLK-	RSVD	SATA_TX-	GND	GBE_LINK100#	SATA_RX-	GND
47	RESET_IN#	GND	PEX1_CLKREQ#	RSVD	GBE_LINK_ACT#	GBE_MD12+	GND	GBE_MD13+
48	CARRIER_PWR_ON	RSVD	PEX0_CLKREQ#	PEX_WAKEN#	GBE_MD10+	GBE_MD11-	GBE_MD12-	GBE_MD13-
49	CHARGER_PRESNT#	RSVD	PEX0_RST#	RSVD	GBE_MD10-	GND	GBE_MD12-	GND
50	VDD_RTC	POWER_BTN#	RSVD	RSVD	PEX1_RST#	GBE_LINK100#	GND	RSVD

2.4.7 CANBUS connector (DB9 Female)

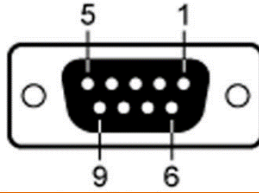

Pin	Signal	Pin	Signal
1		2	CAN0 L
3		4	CAN1 L
5	GND	6	GND
7	CAN0 H	8	CAN1 H
9			

2.4.8 GPIO Port Connector (CN14)

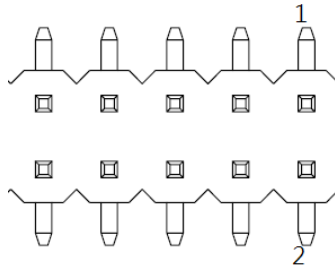

Pin	Signal	Pin	Signal
1	GPIO_EXP_P0	2	GND
3	GPIO_EXP_P1	4	GND
5	GPIO_EXP_P2	6	GND
7	GPIO_EXP_P3	8	GND
9	ACOK	10	GND

2.4.9 HDMI connector (CN8)

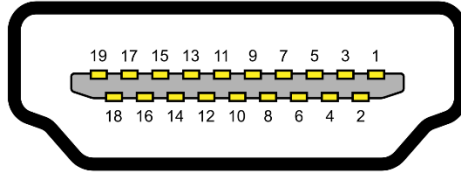

Pin	Signal	Pin	Signal
1	HDMI_DATA2_P	2	GND
3	HDMI_DATA2_N	4	HDMI_DATA1_P
5	GND	6	HDMI_DATA1_N
7	HDMI_DATA0_P	8	GND
9	HDMI_DATA0_N	10	HDMI_CLK_P
11	GND	12	HDMI_CLK_N
13	NC	14	NC
15	HDMI_SCL	16	HDMI_SDA
17	GND	18	HDMI_PWR
19	HDMI_HDP		

2.4.10 USB3.0 connector (CN7)

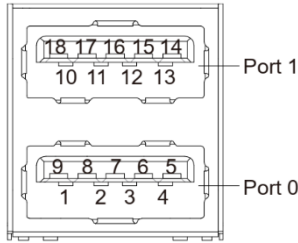

Pin	Signal	Pin	Signal
U1	VBUS_1	U10	VBUS_2
U2	(A)D-	U11	(B)D-
U3	(A)D+	U12	(B)D+
U4	GND	U13	GND
U5	(A)SSRX-	U14	(B)SSRX-
U6	(A)SSRX+	U15	(B)SSRX+
U7	GND	U16	GND
U8	(A)SSTX-	U17	(B)SSTX-
U9	(A)SSTX+	U18	(B)SSTX+

2.4.11 Power in connector (CN2)

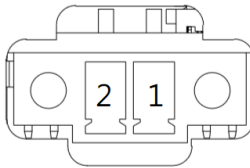

Pin	Signal	Pin	Signal
1	PWR IN	2	GND

2.4.12 COM port connector (Male)

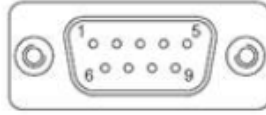

Pin	RS-232
1	
2	RXD
3	TXD
4	
5	GND
6	
7	RTS
8	CTS
9	

2.4.13 LAN (RJ-45) Port

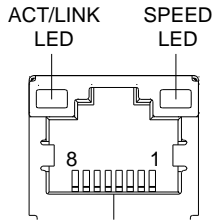

Pin	Signal	Pin	Signal
1	MDI0+	2	MDI0-
3	MDI1+	4	MDI1-
5	MDI2+	6	MDI2-
7	MDI3+	8	MDI3-

2.5 Wall Mount Assembly

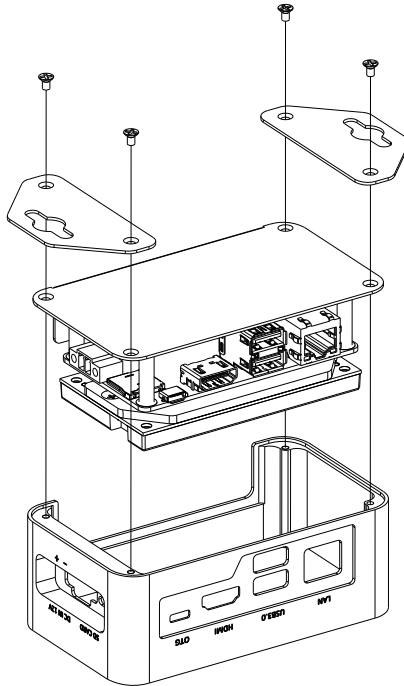
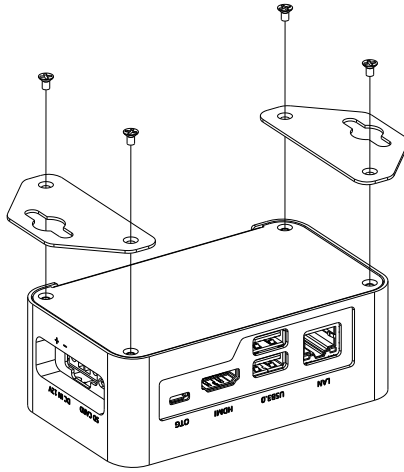

Chapter 3

OS Flash guide

3.1 Force USB Recovery Mode

To place system in Force USB Recovery Mode:

1. Power down the device. If connected, remove the AC adapter from the device. The device MUST be powered OFF, not in a suspend or sleep state.
2. Connect the Micro-B plug on the USB cable to the Recovery (USB Micro-B) Port on the device and the other end to an available USB port on the host PC.
3. Connect the power adapter to the device.
4. Press and release the POWER button to power on device. Press and hold the FORCE RECOVERY button: while pressing the FORCE RECOVERY button, press and release the RESET button; wait two seconds and release the FORCE RECOVERY button.; For the location of the buttons, refer to Chapter 2 Hardware Information.
5. When device is in recovery mode, lsusb command on host will list a line of "Nvidia Corp"

3.2 Software & BSP

Please follow the steps below to install the test image.

(1) Download the image folder from the official AAEON website at:

<https://www.aaeon.com/en/p/fanless-embedded-computers-boxer-8110ai#downloads>

(2) Unzip the Image file

```
unzip [Image File Name]
```

For example:

```
unzip ACLinux_4.9_ACLNX49D.NV02.BOXER-8110-8120-8130AI.6.2.tar
```

(3) Enter bootloader folder

```
cd bootloader
```

(4) Enter Force USB Recovery Mode. Refer to previous section **3.1 Force USB Recovery Mode** for instructions.

(5) Execute the following command to install image:

```
sudo /flashall.sh
```