



BOXER-6839-RPL

Fanless Embedded Controller

User's Manual 1st Ed

Copyright Notice

This document is copyrighted, 2026. All rights are reserved. The original manufacturer reserves the right to make improvements to the products described in this manual at any time without notice.

No part of this manual may be reproduced, copied, translated, or transmitted in any form or by any means without the prior written permission of the original manufacturer. Information provided in this manual is intended to be accurate and reliable. However, the original manufacturer assumes no responsibility for its use, or for any infringements upon the rights of third parties that may result from its use.

The material in this document is for product information only and is subject to change without notice. While reasonable efforts have been made in the preparation of this document to assure its accuracy, AAEON assumes no liabilities resulting from errors or omissions in this document, or from the use of the information contained herein.

AAEON reserves the right to make changes in the product design without notice to its users.

Acknowledgement

All other product name or trademarks are properties of their respective owners.

- Microsoft Windows® is a registered trademark of Microsoft Corp.
- Intel® is a registered trademark of Intel Corporation
- Core™ is a trademark of Intel Corporation
- Linux® is the registered trademark of Linus Torvalds in the U.S. and other countries
- Ubuntu and Canonical are registered trademarks of Canonical Ltd.

All other product names or trademarks are properties of their respective owners. The publisher of this document does not assume nor imply ownership of any trademarked product not listed herein.

Packing List

Before setting up your product, please make sure the following items have been shipped:

Item	Quantity
● BOXER-6839-RPL	1
● Wall Mount Bracket	2
● 3-pin Terminal Block Connector (for DC input)	1
● Thermal Pad Package	1
● Screw Package	1
● Remote On/Off Connector	1

If any of these items are missing or damaged, please contact your distributor or sales representative immediately.

About this Document

This User's Manual contains all the essential information, such as detailed descriptions and explanations on the product's hardware and software features (if any), its specifications, dimensions, jumper/connector settings/definitions, and driver installation instructions (if any), to facilitate users in setting up their product.

Users may refer to the product page at AAEON.com for the latest version of this document.

Safety Precautions

Please read the following safety instructions carefully. It is advised that you keep this manual for future references

1. All cautions and warnings on the device should be noted.
2. Make sure the power source matches the power rating of the device.
3. Position the power cord so that people cannot step on it. Do not place anything over the power cord.
4. Always completely disconnect the power before working on the system's hardware.
5. No connections should be made when the system is powered as a sudden rush of power may damage sensitive electronic components.
6. If the device is not to be used for a long time, disconnect it from the power supply to avoid damage by transient over-voltage.
7. Always disconnect this device from any power supply before cleaning.
8. While cleaning, use a damp cloth instead of liquid or spray detergents.
9. Make sure the device is installed near a power outlet and is easily accessible.
10. Keep this device away from humidity.
11. Place the device on a solid surface during installation to prevent falls.
12. Do not cover the openings on the device to ensure optimal heat dissipation.
13. Watch out for high temperatures when the system is running.
14. Do not touch the heat sink or heat spreader when the system is running
15. Never pour any liquid into the openings. This could cause fire or electric shock.
16. As most electronic components are sensitive to static electrical charge, be sure to ground yourself to prevent static charge when installing the internal components. Use a grounding wrist strap and contain all electronic components in any static-shielded containers.

17. If any of the following situations arises, please the contact our service personnel:
 - i. Damaged power cord or plug
 - ii. Liquid intrusion to the device
 - iii. Exposure to moisture
 - iv. Device is not working as expected or in a manner as described in this manual
 - v. The device is dropped or damaged
 - vi. Any obvious signs of damage displayed on the device
18. Do not leave this device in an uncontrolled environment with temperatures beyond the device's permitted storage temperatures (see chapter 1) to prevent damage.
19. Do NOT disassemble the motherboard so as not to damage the system or void your warranty.
20. If the thermal pad had been damaged, please contact AAEON's salesperson to purchase a new one. Do NOT use those of other brands.
21. The Hex Cylinder Coppers on the front panel are not removable.
22. Repeatedly assemble and disassemble the system may cause damages to the exterior paint and surface and screw holes.
23. Use the right size screwdriver.
24. Use the screwdriver correctly to remove screws from the system.

FCC Statement

Warning!



This device complies with Part 15 FCC Rules. Operation is subject to the following two conditions: (1) this device may not cause harmful interference, and (2) this device must accept any interference received including interference that may cause undesired operation.

Caution:

There is a danger of explosion if the battery is incorrectly replaced. Replace only with the same or equivalent type recommended by the manufacturer. Dispose of used batteries according to the manufacturer's instructions and your local government's recycling or disposal directives.

Attention:

Il y a un risque d'explosion si la batterie est remplacée de façon incorrecte. Ne la remplacer qu'avec le même modèle ou équivalent recommandé par le constructeur. Recycler les batteries usées en accord avec les instructions du fabricant et les directives gouvernementales de recyclage.

产品中有毒有害物质或元素名称及含量

AAEON System

QO4-381 Rev.A2

部件名称	有毒有害物质或元素					
	铅 (Pb)	汞 (Hg)	镉 (Cd)	六价铬 (Cr(VI))	多溴联苯 (PBB)	多溴二苯醚 (PBDE)
印刷电路板 及其电子组件	×	○	○	○	○	○
外部信号 连接器及线材	×	○	○	○	○	○
外壳	○	○	○	○	○	○
中央处理器 与内存	×	○	○	○	○	○
硬盘	×	○	○	○	○	○
液晶模块	×	○	○	○	○	○
光驱	×	○	○	○	○	○
触控模块	×	○	○	○	○	○
电源	×	○	○	○	○	○
电池	×	○	○	○	○	○

本表格依据 SJ/T 11364 的规定编制。

○：表示该有毒有害物质在该部件所有均质材料中的含量均在 GB/T 26572 标准规定的限量要求以下。

×：表示该有害物质的某一均质材料超出了 GB/T 26572 的限量要求，然而该部件仍符合欧盟指令 2011/65/EU 的规范。

环保使用期限(EFUP (Environmental Friendly Use Period))：10 年

备注：

一、此产品所标示之环保使用期限，系指在一般正常使用状况下。

二、上述部件物质中央处理器、内存、硬盘、光驱、电源为选购品。

三、上述部件物质液晶模块、触控模块仅一体机产品适用。

China RoHS Requirement (EN)

Name and content of hazardous substances in product

AAEON System

QO4-381 Rev.A2

Part Name	Hazardous Substances					
	铅 (Pb)	汞 (Hg)	镉 (Cd)	六价铬 (Cr(VI))	多溴联苯 (PBB)	多溴二苯醚 (PBDE)
PCB Assemblies	×	○	○	○	○	○
Connector and Cable	×	○	○	○	○	○
Chassis	○	○	○	○	○	○
CPU and Memory	×	○	○	○	○	○
Hard Disk	×	○	○	○	○	○
LCD Modules	×	○	○	○	○	○
CD-ROM/DVD-ROM	×	○	○	○	○	○
Touch Modules	×	○	○	○	○	○
Power	×	○	○	○	○	○
Battery	×	○	○	○	○	○

The table is prepared in accordance with the provisions of SJ/T 11364.

○ : Indicates that said hazardous substance contained in all of the homogenous materials for this product is below the limit requirement of GB/T 26572.

× : Indicates that said hazardous substance contained in at least one of the homogenous materials used for this part is above the limit requirement of GB/T 26572. But this product still be compliance with 2011/65/EU Directive (allowed with 2011/65/EU Annex III of RoHS exemption with number 6(c),7(a),7(c)-1).

EFUP (Environment Friendly Use Period) value: 10 years.

Notes:

1. This product defined period of use is under normal condition.
2. In above part, CPU/Memory/ Hard Disk/CD-ROM/DVD-ROM/ Power are optional.
3. In above part, LCD Modules/ Touch Modules are for all-in-one product model.

Table of Contents

- Chapter 1 - Product Specifications 1
 - 1.1 Specifications..... 2
- Chapter 2 – Hardware Information 5
 - 2.1 Dimensions 6
 - 2.2 System Ports.....7
 - 2.2.1 DC-in (12V – 24V) (1)..... 9
 - 2.2.2 COM Port 1 – 6 (RS-232/422/485) (2)..... 9
 - 2.2.3 Dual Display Port (3)10
 - 2.2.4 Dual HDMI Port (4).....11
 - 2.2.5 Reset Key (5)12
 - 2.2.6 System On/Off (with Green LED) (6)13
 - 2.2.7 SYS (Green) / HDD (Red) LED (7)13
 - 2.2.8 Remote Switch (8).....13
 - 2.2.9 Audio Port (Line Out / Mic-in) (9)14
 - 2.2.10 Digital IO Port (10)14
 - 2.2.11 GbE LAN (RJ-45) + Dual USB 3.2 Port (11)15
 - 2.2.12 2.5GbE LAN (RJ-45) + Dual USB 3.2 Port (12)16
 - 2.2.13 GbE LAN (RJ-45) + Dual USB 3.2 Port (13).....18
 - 2.2.14 GbE LAN (RJ-45) + Dual USB 3.2 Port (13).....19
 - 2.3 Main Board Jumpers and Connectors21
 - 2.4 List of Jumpers24
 - 2.4.1 Clear CMOS Jumper (JP1)25
 - 2.4.2 ATX/AT Mode Selection (JP3)25
 - 2.5 List of Connectors26
 - 2.5.1 PCIe [x4] Slot (CN1)27
 - 2.5.2 HDMI Port (CN3).....29

2.5.3	Dual Display Port (CN4)	30
2.5.4	GbE LAN (RJ-45) + Dual USB 3.2 Connector (CN5)	32
2.5.5	2.5GbE LAN (RJ-45) + Dual USB 3.2 Connector (CN6).....	33
2.5.6	GbE LAN (RJ-45) + Dual USB 3.2 Connector (CN7).....	35
2.5.7	GbE LAN (RJ-45) + Dual USB 3.2 Connector (CN8)	36
2.5.8	M.2 3052 B-Key Slot (CN9).....	37
2.5.9	SIM Slot (CN10).....	39
2.5.10	M.2 2230 E-Key Slot (CN11)	40
2.5.11	Remote Button Connector (CN13)	40
2.5.12	SPI Flash Port (CN14).....	41
2.5.13	Debug Card Connector (CN15)	42
2.5.14	SATA Port 1/Port 2 (CN16/CN17).....	43
2.5.15	SATA Power Connector (CN18/CN19).....	44
2.5.16	DIO (Wafer Box) (CN20)	44
2.5.17	Dual COM Connector (RS-232/422/485) (CN22/CN23).....	45
2.5.18	USB 2.0 Wafer Box (CN24/CN25/CN26/CN27).....	46
2.5.19	Audio Connector (CN28)	47
2.5.20	Audio Wafer (10P pitch:1.25mm, Optional) (CN29)	48
2.5.21	Power Input Connector (CN30)	49
2.5.22	M.2 2280 M-Key Slot (CN31)	49
2.5.23	Fan Connector (CN32).....	51
2.5.24	COM Port 5 (Wafer Box, Optional) (CN33)	51
2.5.25	COM Port 6 (Wafer Box, Optional) (CN34)	52
2.5.26	A1 SKU Riser Card	53
2.5.27	A2 SKU Riser Card	53
2.6	CPU Installation.....	54
2.7	RAM Module Installation	55
2.8	SATA Installation.....	57

2.9	NVMe Installation.....	59
2.10	PCIe Card Installation	61
2.10	Wall Mount Bracket Installation.....	63
Chapter 3 - AMI BIOS Setup.....		64
3.1	System Test and Initialization	65
3.2	AMI BIOS Setup.....	66
3.3	Setup Submenu: Main.....	67
3.4	Setup Submenu: Advanced	68
3.4.1	CPU Configuration	69
3.4.2	Memory Configuration.....	70
3.4.3	PCH-FW Configuration.....	71
3.4.3.1	Firmware Update Configuration	72
3.4.4	Hardware Monitor	73
3.4.5	Power Management.....	74
3.4.6	AAEON BIOS Robot.....	75
3.4.6.1	Device Detecting Configuration	77
3.5	Setup Submenu: Chipset	83
3.5.1	Storage Configuration	84
3.5.2	NVMe Configuration.....	85
3.5.3	HD Audio Configuration	86
3.5.4	Digital IO Port Configuration	87
3.5.5	Legacy Logical Devices Configuration	89
3.5.5.1	Serial Port 1.....	90
3.5.5.2	Serial Port 2	91
3.5.5.3	Serial Port 3	92
3.5.5.4	Serial Port 4.....	93
3.5.5.5	Serial Port 5	94
3.5.5.6	Serial Port 6.....	95

3.5.6	Serial Port Console Redirection.....	96
3.5.6.1	Console Redirection Settings (COM0).....	97
3.5.6.2	Console Redirection Settings (Out-of-Band Mgmt)	99
3.6	Setup Submenu: Security	101
3.6.1	Trusted Computing.....	102
3.6.2	Secure Boot.....	104
3.6.2.1	Key Management.....	105
3.7	Setup Submenu: Boot.....	107
3.7.1	UEFI BBS Priorities.....	108
3.8	Setup Submenu: Save & Exit	109
3.9	Setup Submenu: MEBx.....	110
Chapter 4	– Drivers Installation	111
4.1	Drivers Download and Installation.....	112
Appendix A	- I/O Information.....	113
A.1	I/O Address Map.....	114
A.2	IRQ Mapping Chart	115
A.3	Memory Address Map.....	116

Chapter 1

Product Specifications

1.1 Specifications

System

CPU	14th Generation Intel® Core™ Processors: Intel® Core™ i9 processor 14900/14900T Intel® Core™ i9 processor 14901E/14901TE Intel® Core™ i7 processor 14700/14700T Intel® Core™ i7 processor 14701E/14701TE Intel® Core™ i5 processor 14500/14500T Intel® Core™ i5 processor 14400 Intel® Core™ i3 processor 14100/14100T 13th Generation Intel® Core™ Processors: Intel® Core™ i9-13900TE/13900E Intel® Core™ i7-13700TE/i7-13700E Intel® Core™ i5-13500TE/13500E Intel® Core™ i3-13100TE/13100E 12th Generation Intel® Core™/Celeron® Processors: Intel® Core™ i9-12900E/12700TE Intel® Core™ i7-12700E/12500TE Intel® Core™ i5-12500E/12100TE Intel® Core™ i3-12100E Intel® Celeron® Processor G6900TE/G6900E
Chipset	Intel® Q670E Chipset
System Memory	DDR5 4800, SODIMM x 2, up to 64GB
Display Interface	HDMI x 2 Display Port x 2
Storage	2.5" SATA Drive Bay x 2 M.2 2280 M-Key x 1 (PCIe Gen 4 [x4]) for NVMe

System

Note: Additional heatsink is required, refer to optional accessories.

Ethernet

RJ-45 for 2.5GbE LAN x 1

RJ-45 for GbE LAN x 3

I/O

USB 3.2 Gen 2 (Type-A) x 8

DB-9 for RS-232/422/485 x 6

Mic-in / Line-out x 1

10-pin Terminal Block for DIO 8-bit x 1

Remote Power On/Off x 1

2-pin Remote Power Switch x 1

Power Button with LED Indicator x 1

Expansion

M.2 2230 E-Key x 1 (Wi-Fi)

M.2 3052 B-Key x 1 with Nano SIM (LTE/5G)

M.2 2280 M-Key x 1 (NVMe)

A1 SKU: PCIe [x4] x 1 + PCIe [x1] x 1 (Total Power Consumption: 25W)

A2 SKU: PCIe [x4] x 1 + PCI x 1 (Total Power Consumption: 25W)

Maximum Expansion Card Size: 150mm × 105mm × 40mm (applicable to both slots)

Indicator

System LED x 1

HDD LED x 1

OS Support

Windows® 10 IoT LTSC 2021

Windows® 11 IoT LTSC 2024

Ubuntu 24.04 and later

Power Supply

Power Requirement	12V – 24V DC-in via 3-pin Terminal Block Connector with protection circuit
--------------------------	--

Mechanical

Mounting	Wall Mount
Dimensions (W x H x D)	10.3" x 7.3" x 4.8" (264mm x 186mm x 122mm) w/o Brackets
Gross Weight	16.1 lb (7.3 kg)
Net Weight	12.4 lb (5.6 kg)

Environmental

Operating Temperature	-4°F – 122°F (-20°C – 50°C) with 0.7 m/s airflow (with wide temp. memory/ storage)
Storage Temperature	-40°F – 176°F (-40°C – 80°C)
Storage Humidity	5 – 95% @ 40°C, non-condensing
Anti-Vibration	With SSD: Random, 3Grms, 5~500Hz
Anti-Shock	With SSD: 50G @ wall mount, half-sine, 11ms
Certification	CE/FCC Class A

Chapter 2

Hardware Information

2.2 System Ports

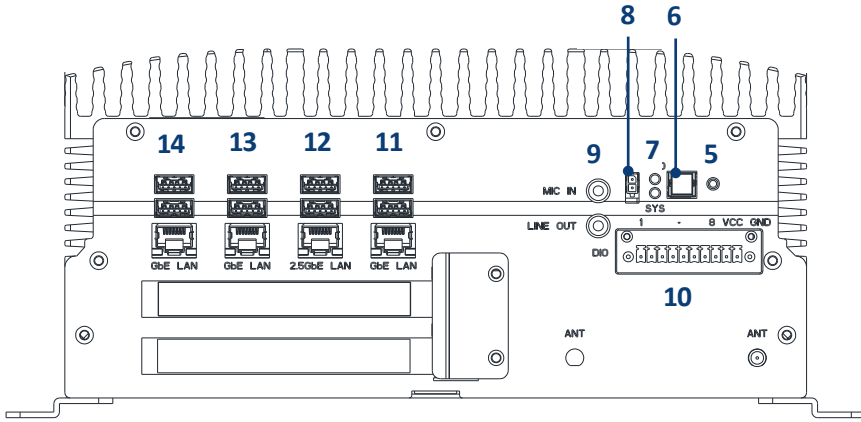
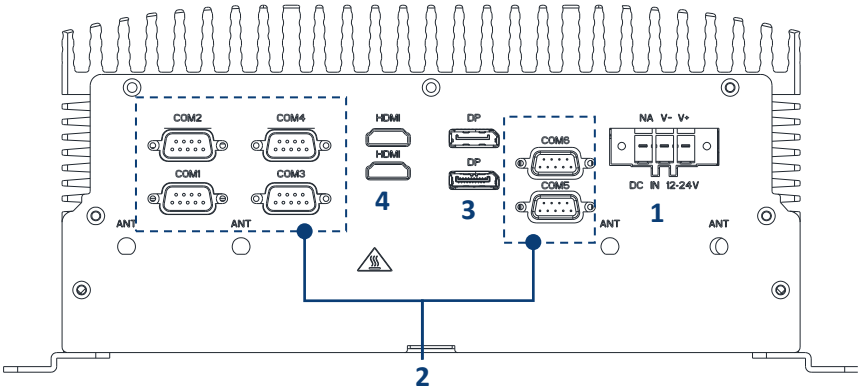

Label	Function
1	DC-in (12V – 24V)
2	COM Port 1 – 6 (RS-232/422/485)
3	Dual Display Port
4	Dual HDMI Port
5	Reset Key
6	System On/Off (with Green LED)
7	SYS (Green) / HDD (Red) LED

Label	Function
8	Remote Switch
9	Audio Port (Line Out / Mic-in)
10	Digital IO Port
11	GbE LAN (RJ-45) + Dual USB 3.2 Port
12	2.5GbE LAN (RJ-45) + Dual USB 3.2 Port
13	GbE LAN (RJ-45) + Dual USB 3.2 Port
14	GbE LAN (RJ-45) + Dual USB 3.2 Port

2.2.1 DC-in (12V – 24V) (1)

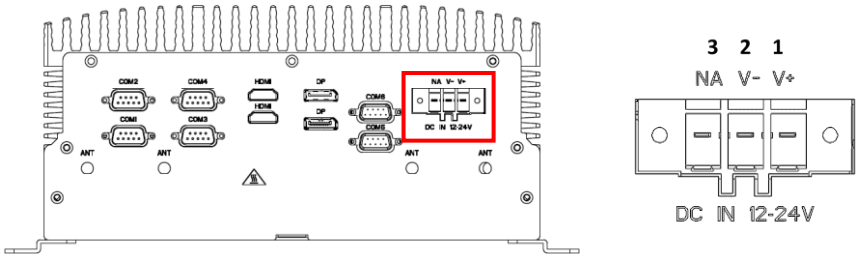

Pin	Pin Name	Signal Type	Signal Level
1	V+	PWR (Vin)	+12V ~ +24V
2	V-	GND	
3	NA	NA	

2.2.2 COM Port 1 – 6 (RS-232/422/485) (2)

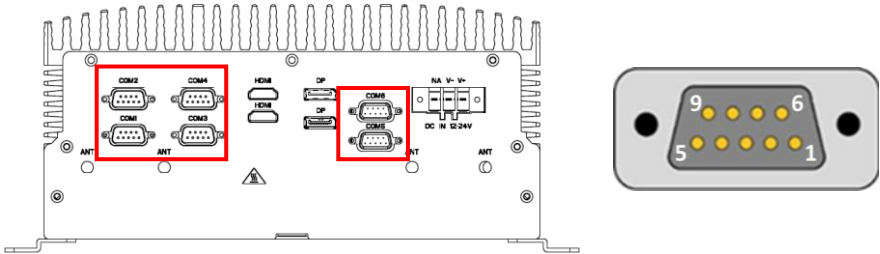

Pin	RS-232	RS-422	RS-485	Signal Type
1	DCD	RS422_TX-	RS485_D-	IN
2	RX	RS422_TX+	RS485_D+	IN
3	TX	RS422_RX+		OUT
4	DTR	RS422_RX-		OUT
5	GND			GND
6	DSR			IN
7	RTS			OUT
8	CTS			IN
9	RI			IN

2.2.3 Dual Display Port (3)

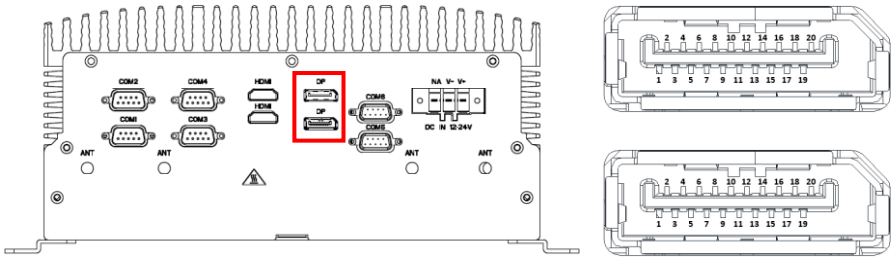

Pin	Signal	Signal Type	Signal Level
P1	DP1_DATA0_P	DIFF	
P2	GND	GND	
P3	DP1_DATA0_N	DIFF	
P4	DP1_DATA1_P	DIFF	
P5	GND	GND	
P6	DP1_DATA1_N	DIFF	
P7	DP1_DATA2_P	DIFF	
P8	GND	GND	
P9	DP1_DATA1_N	DIFF	
P10	DP1_DATA3_P	DIFF	
P11	GND	GND	
P12	DP1_DATA3_N	DIFF	
P13	CONFIG1		
P14	CONFIG2		
P15	DP1_AUX_P	DIFF	
P16	GND	GND	
P17	DP1_AUX_N	DIFF	
P18	DP1_HPD		
P19	RETURN		
P20	DP1_PWR	PWR	+3.3V
P21	DP2_DATA0_P	DIFF	
P22	GND	GND	
P23	DP2_DATA0_N	DIFF	
P24	DP2_DATA1_P	DIFF	
P25	GND	GND	
P26	DP2_DATA1_N	DIFF	
P27	DP2_DATA2_P	DIFF	
P28	GND	GND	

Pin	Signal	Signal Type	Signal Level
P29	DP2_DATA1_N	DIFF	
P30	DP2_DATA3_P	DIFF	
P31	GND	GND	
P32	DP2_DATA3_N	DIFF	
P33	CONFIG1		
P34	CONFIG2		
P35	DP2_AUX_P	DIFF	
P36	GND	GND	
P37	DP2_AUX_N	DIFF	
P38	DP2_HPD		
P39	RETURN		
P40	DP2_PWR	PWR	+3.3V

2.2.4 Dual HDMI Port (4)

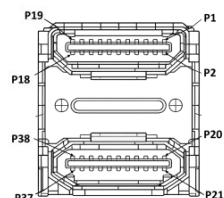
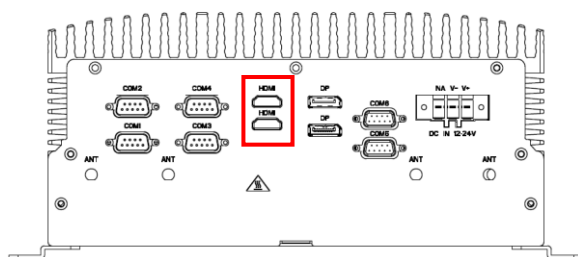

Pin	Signal	Signal Type	Signal Level
P1	HDMI1_DATA2_P	DIFF	
P2	GND	GND	
P3	HDMI1_DATA2_N	DIFF	
P4	HDMI1_DATA1_P	DIFF	
P5	GND	GND	
P6	HDMI1_DATA1_N	DIFF	
P7	HDMI1_DATA0_P		
P8	GND	GND	
P9	HDMI1_DATA0_n		
P10	HDMI1_CLK_P	DIFF	
P11	GND	GND	
P12	HDMI1_CLK_N	DIFF	
P13	CEC		3.3V
P14	NC		

Pin	Signal	Signal Type	Signal Level
P15	HDMI1_SCL		
P16	HDMI1_SDA		
P17	GND	GND	
P18	+V5S_HDMI_CON	PWR	5V
P19	HDMI1_HPD		5V
P20	HDMI2_DATA2_P		
P21	GND	GND	
P22	HDMI2_DATA2_N		
P23	HDMI2_DATA1_P		
P24	GND	GND	
P25	HDMI2_DATA1_N		
P26	HDMI2_DATA0_P		
P27	GND	GND	
P28	HDMI2_DATA0_N		
P29	HDMI2_CLK_P		
P30	GND	GND	
P31	HDMI2_CLK_N		
P32	CEC		3.3V
P33	NC		
P34	HDMI2_SCL		
P35	HDMI2_SDA		
P36	GND	GND	
P37	+V5S_HDMI_CON		5V
P38	HDMI2_HPD		5V

2.2.5 Reset Key (5)

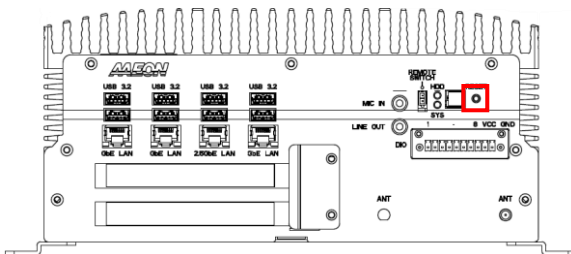

RESET



2.2.6 System On/Off (with Green LED) (6)

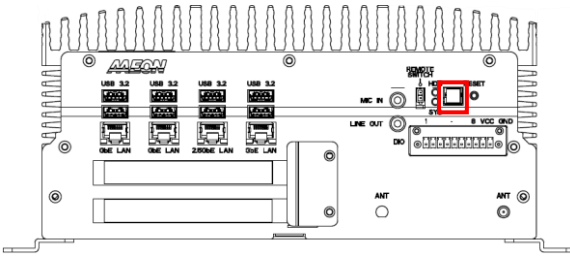

2.2.7 SYS (Green) / HDD (Red) LED (7)

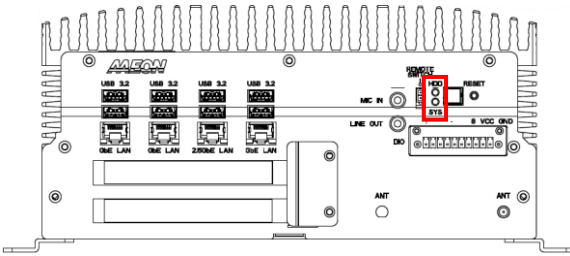

2.2.8 Remote Switch (8)

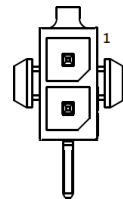
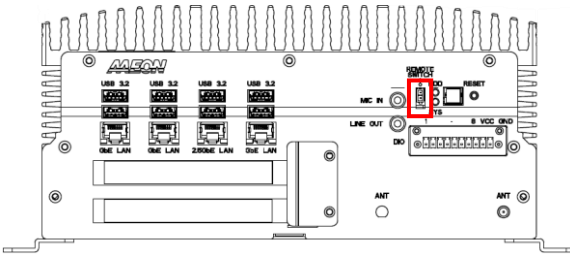

Pin	Signal	Signal Type
1	PWR_BUTTON	IN
2	GND	GND

2.2.9 Audio Port (Line Out / Mic-in) (9)

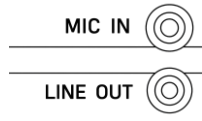
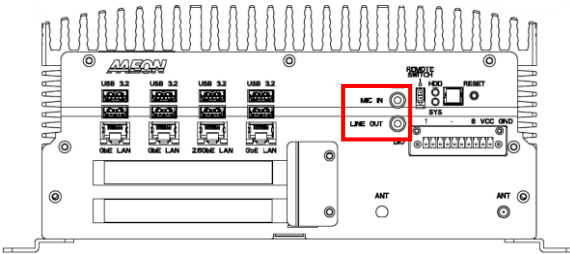

Note: Compatible with standard 3.5 mm male plug pins.

2.2.10 Digital IO Port (10)

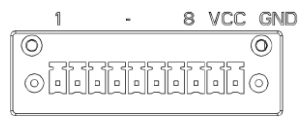
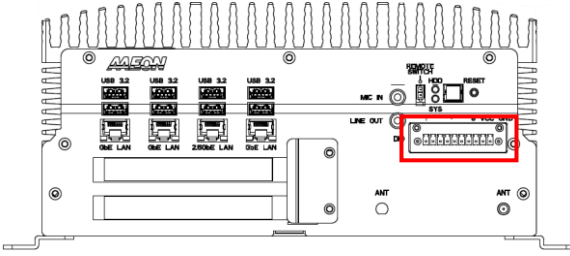

Pin	Signal	Signal Type	Signal Level
1	DIO0	I/O	+5V
2	DIO1	I/O	+5V
3	DIO2	I/O	+5V
4	DIO3	I/O	+5V
5	DIO4	I/O	+5V
6	DIO5	I/O	+5V
7	DIO6	I/O	+5V

Pin	Signal	Signal Type	Signal Level
8	DIO7	I/O	+5V
9	+5V	PWR	+5V
10	GND	GND	

2.2.11 GbE LAN (RJ-45) + Dual USB 3.2 Port (11)

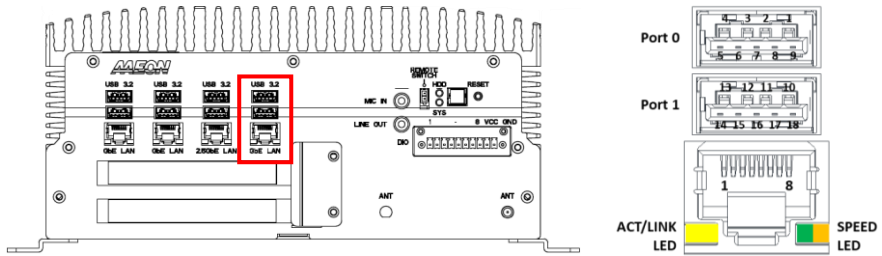

LAN			
Pin	Signal	Signal Type	Signal Level
1	MDI0+	DIFF	
2	MDI0-	DIFF	
3	MDI1+	DIFF	
4	MDI2+	DIFF	
5	MDI2-	DIFF	
6	MDI1-	DIFF	
7	MDI3+	DIFF	
8	MDI3-	DIFF	

USB			
Pin	Signal	Signal Type	Signal Level
1	+5VSB	PWR	+5V
2	USB1_D-	DIFF	
3	USB1_D+	DIFF	
4	GND	GND	
5	USB1_SSRX-	DIFF	
6	USB1_SSRX+	DIFF	
7	GND	GND	
8	USB1_SSTX-	DIFF	
9	USB1_SSTX+	DIFF	
10	+5VSB	PWR	+5V
11	USB2_D-	DIFF	

USB			
Pin	Signal	Signal Type	Signal Level
12	USB2_D+	DIFF	
13	GND	GND	
14	USB2_SSRX-	DIFF	
15	USB2_SSRX+	DIFF	
16	GND	GND	
17	USB2_SSTX-	DIFF	
18	USB2_SSTX+	DIFF	

ACT/LINK LED		SPEED LED	
Status	Description	Status	Description
-	-	Green	10/100Mbps
Off	No Link	Orange	1Gbps
Yellow	Linked	-	-
Blinking	Data Activity	-	-

2.2.12 2.5GbE LAN (RJ-45) + Dual USB 3.2 Port (12)

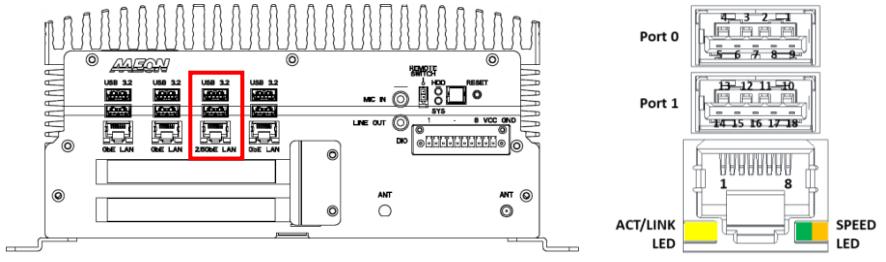

LAN			
Pin	Signal	Signal Type	Signal Level
1	MDI0+	DIFF	
2	MDI0-	DIFF	
3	MDI1+	DIFF	
4	MDI2+	DIFF	
5	MDI2-	DIFF	
6	MDI1-	DIFF	
7	MDI3+	DIFF	
8	MDI3-	DIFF	

USB			
Pin	Signal	Signal Type	Signal Level
1	+5VSB	PWR	+5V
2	USB3_D-	DIFF	
3	USB3_D+	DIFF	
4	GND	GND	
5	USB3_SSRX-	DIFF	
6	USB3_SSRX+	DIFF	
7	GND	GND	
8	USB3_SSTX-	DIFF	
9	USB3_SSTX+	DIFF	
10	+5VSB	PWR	+5V
11	USB4_D-	DIFF	
12	USB4_D+	DIFF	
13	GND	GND	
14	USB4_SSRX-	DIFF	
15	USB4_SSRX+	DIFF	
16	GND	GND	
17	USB4_SSTX-	DIFF	
18	USB4_SSTX+	DIFF	

ACT/LINK LED		SPEED LED	
Status	Description	Status	Description
-	-	Green	2.5Gbps
Off	No Link	Orange	1Gbps
Yellow	Linked	Off	100Mbps
Blinking	Data Activity	Off	10Mbps

2.2.13 GbE LAN (RJ-45) + Dual USB 3.2 Port (13)

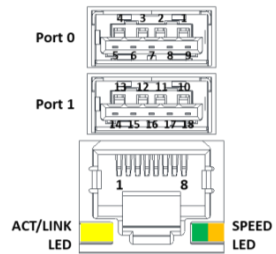
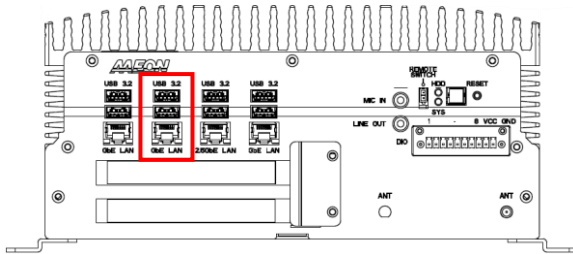

LAN			
Pin	Signal	Signal Type	Signal Level
1	MDI0+	DIFF	
2	MDI0-	DIFF	
3	MDI1+	DIFF	
4	MDI2+	DIFF	
5	MDI2-	DIFF	
6	MDI1-	DIFF	
7	MDI3+	DIFF	
8	MDI3-	DIFF	

USB			
Pin	Signal	Signal Type	Signal Level
1	+5VSB	PWR	+5V
2	USB5_D-	DIFF	
3	USB5_D+	DIFF	
4	GND	GND	
5	USB5_SSRX-	DIFF	
6	USB5_SSRX+	DIFF	
7	GND	GND	
8	USB5_SSTX-	DIFF	
9	USB5_SSTX+	DIFF	
10	+5VSB	PWR	+5V
11	USB6_D-	DIFF	
12	USB6_D+	DIFF	
13	GND	GND	
14	USB6_SSRX-	DIFF	
15	USB6_SSRX+	DIFF	
16	GND	GND	

USB			
Pin	Signal	Signal Type	Signal Level
17	USB6_SSTX-	DIFF	
18	USB6_SSTX+	DIFF	

ACT/LINK LED		SPEED LED	
Status	Description	Status	Description
-	-	Green	10/100Mbps
Off	No Link	Orange	1Gbps
Yellow	Linked	-	-
Blinking	Data Activity	-	-

2.2.14 GbE LAN (RJ-45) + Dual USB 3.2 Port (13)

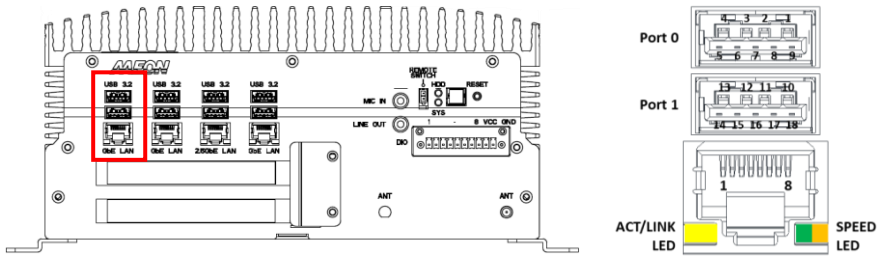

LAN			
Pin	Signal	Signal Type	Signal Level
1	MDI0+	DIFF	
2	MDI0-	DIFF	
3	MDI1+	DIFF	
4	MDI2+	DIFF	
5	MDI2-	DIFF	
6	MDI1-	DIFF	
7	MDI3+	DIFF	
8	MDI3-	DIFF	

USB			
Pin	Signal	Signal Type	Signal Level
1	+5VSB	PWR	+5V
2	USB7_D-	DIFF	
3	USB7_D+	DIFF	

USB			
Pin	Signal	Signal Type	Signal Level
4	GND	GND	
5	USB7_SSRX-	DIFF	
6	USB7_SSRX+	DIFF	
7	GND	GND	
8	USB7_SSTX-	DIFF	
9	USB7_SSTX+	DIFF	
10	+5VSB	PWR	+5V
11	USB8_D-	DIFF	
12	USB8_D+	DIFF	
13	GND	GND	
14	USB8_SSRX-	DIFF	
15	USB8_SSRX+	DIFF	
16	GND	GND	
17	USB8_SSTX-	DIFF	
18	USB8_SSTX+	DIFF	

ACT/LINK LED		SPEED LED	
Status	Description	Status	Description
-	-	Green	10/100Mbps
Off	No Link	Orange	1Gbps
Yellow	Linked	-	-
Blinking	Data Activity	-	-

2.3 Main Board Jumpers and Connectors

Top

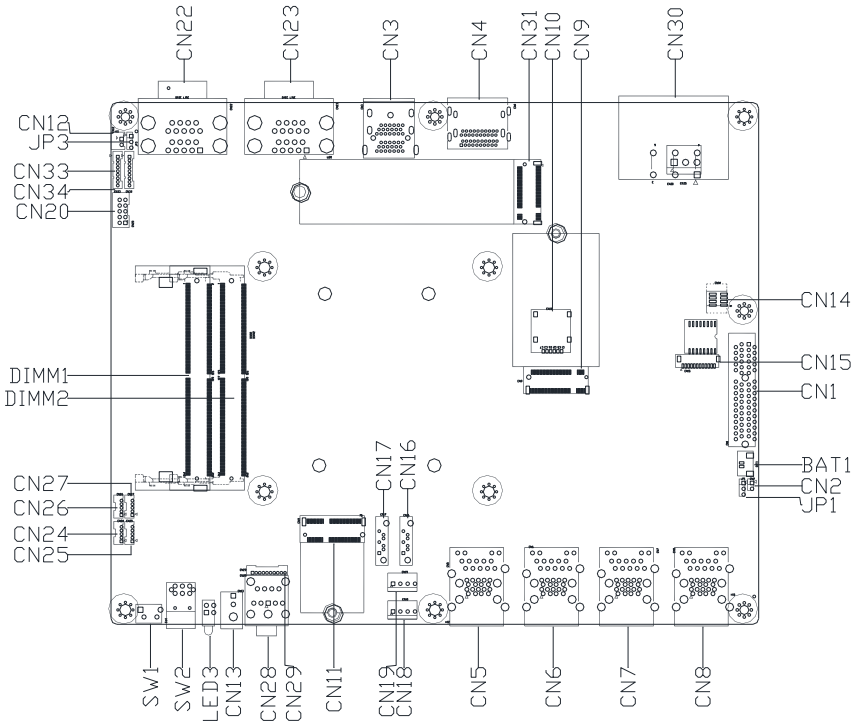

Bottom

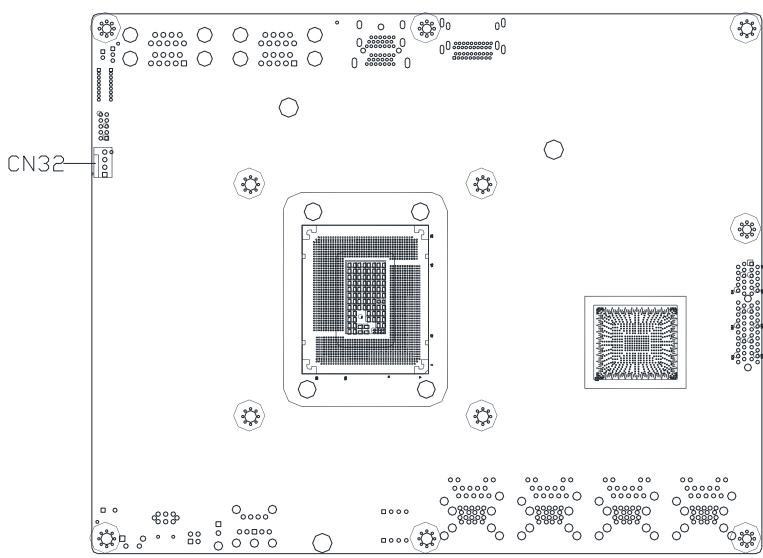

M.2 Key Location

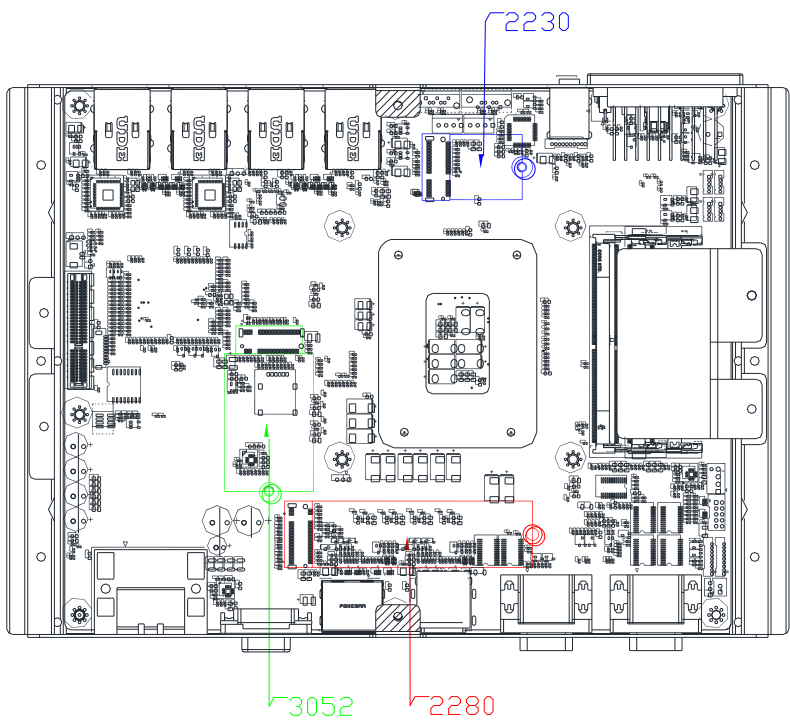

2.4 List of Jumpers

Please refer to the table below for all of the system's jumpers that you can configure for your application.

Label	Function
JP1	CMOS Control Selection
JP3	ATX/AT Mode Selection

The BOXER-6839-RPL comes with several jumpers which allow you to configure the system by either setting the jumper to "open" or "closed"; or by selecting certain pins. A closed jumper has two pins connected with a jumper clip, while an open jumper has no pins connected.

For jumpers with multiple pins, this guide uses "pins A-B" to notate which pins should be connected by a jumper clip. For example, "pins 1-2" means you should connect pins 1 and 2, while "pins 2-3" means you should connect pins 2 and 3.

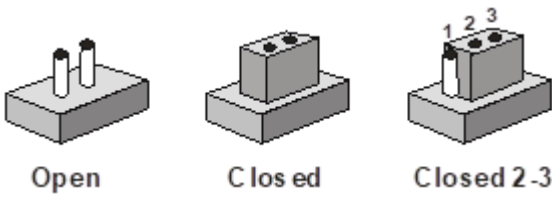

A pair of needle-nose pliers may be helpful when working with jumpers.

If you have any questions about how best to configure the system for your application, contact your AAEON representative or visit our website to talk with our support team.

2.4.1 Clear CMOS Jumper (JP1)

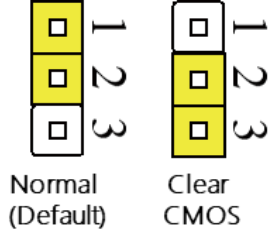
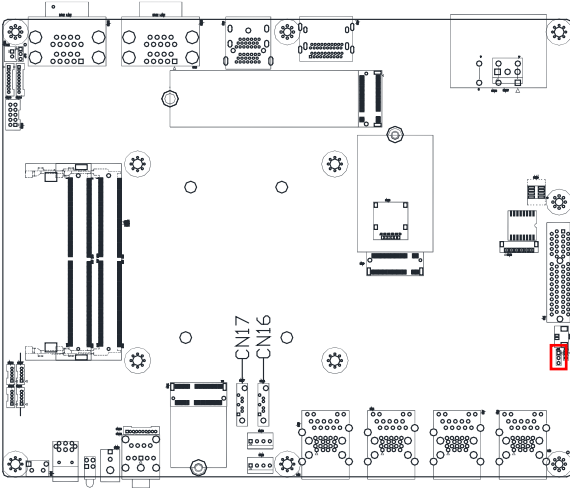

2.4.2 ATX/AT Mode Selection (JP3)

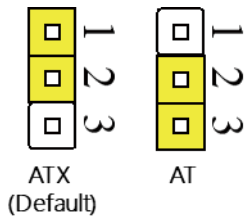
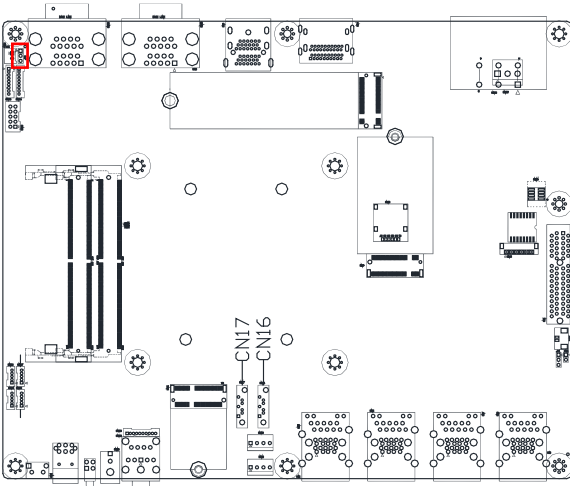

Note: AT Mode JP3(2-3): ATX power button JP3 (1-2) to power on the system.

2.5 List of Connectors

Please refer to the table below for all of the system's connectors that you can configure for your application

Label	Function
CN1	PCIe [x4] Slot
CN3	Dual HDMI Port
CN4	Dual Display Port
CN5	LAN + Dual USB 3.2 Stack Connector
CN6	LAN + Dual USB 3.2 Stack Connector
CN7	LAN + Dual USB 3.2 Stack Connector
CN8	LAN + Dual USB 3.2 Stack Connector
CN9	M.2 3052 B-Key Slot
CN10	SIM Slot
CN11	M.2 2230 E-Key Slot
CN13	Remote Button
CN14	SPI Flash Port
CN15	eSPI Port
CN16	SATA 1
CN17	SATA 2
CN18	SATA Power Connector
CN19	SATA Power Connector
CN20	DIO (Wafer Box)
CN22	COM 1 + COM 2 Connector (RS-232/422/485)
CN23	COM 3 + COM 4 Connector (RS-232/422/485)
CN24	USB 2.0 (Header, Optional)
CN25	USB 2.0 (Header, Optional)
CN26	USB 2.0 (Header, Optional)
CN27	USB 2.0 (Header, Optional)
CN28	Audio Connector
CN29	Audio Wafer (Optional)
CN30	Phoenix Connector Power Input
CN31	M.2 2280 M-Key Slot
CN32	Fan Connector
CN33	COM 5 Header (RS-232/422/485)
CN34	COM 6 Header (RS-232/422/485)
BAT1	RTC Battery
SW1	Reset Switch
SW2	Power Button

2.5.1 PCIe [x4] Slot (CN1)

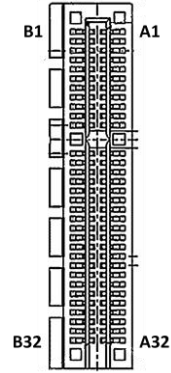
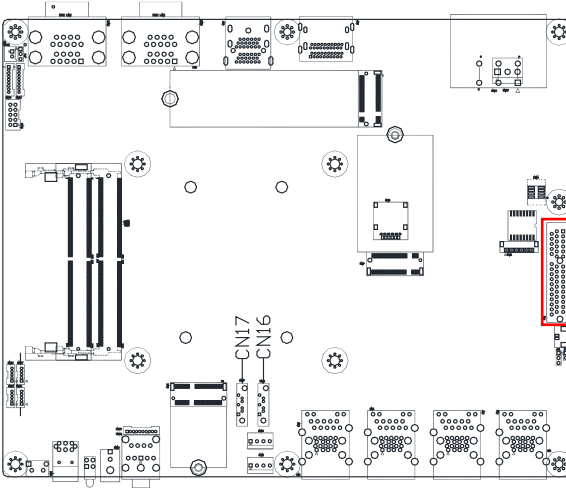

Pin	Pin Name	Signal Type	Signal Level
A1	PRSENT1#	I/O	
A2	+12V	PWR	+V12S
A3	+12V	PWR	+V12S
A4	GND	GND	
A5	PCIE_TXN5	DIFF	
A6	PCIE_TXP5	DIFF	
A7	PCIE_RXN5	DIFF	
A8	PCIE_RXP5	DIFF	
A9	+3.3V	PWR	+V3.3S
A10	+3.3V	PWR	+V3.3S
A11	PERST#	I/O	
A12	GND	GND	
A13	PCIE_x4SLOT_CLK	DIFF	
A14	PCIE_x4SLOT_CLK#	DIFF	
A15	GND	GND	
A16	PCIE_RXP24	DIFF	
A17	PCIE_RXN24	DIFF	
A18	GND	GND	
A19	NC		
A20	GND	GND	
A21	PCIE_RXP23	DIFF	
A22	PCIE_RXN23	DIFF	

Pin	Pin Name	Signal Type	Signal Level
A23	GND	GND	
A24	GND	GND	
A25	PCIE_RXP22	DIFF	
A26	PCIE_RXP22	DIFF	
A27	GND	GND	
A28	GND	GND	
A29	PCIE_RXP21	DIFF	
A30	PCIE_RXN21	DIFF	
A31	GND	GND	
A32	NC		
B1	+12V	PWR	+V12S
B2	+12V	PWR	+V12S
B3	+12V	PWR	+V12S
B4	GND	GND	
B5	SMB_CLK	I/O	
B6	SMB_DATA	I/O	
B7	GND	GND	
B8	+V3.3S	PWR	+V3.3S
B9	NC		
B10	3.3Vaux	PWR	+V3.3A
B11	WAKE#	I/O	
B12	NC		
B13	GND	GND	
B14	PCIE_TXP24	DIFF	
B15	PCIE_TXN24	DIFF	
B16	GND	GND	
B17	PRSNT	I/O	
B18	GND	GND	
B19	PCIE_TXP23	DIFF	
B20	PCIE_TXN23	DIFF	
B21	GND	GND	
B22	GND	GND	
B23	PCIE_TXP22	DIFF	
B24	PCIE_TXN22	DIFF	
B25	GND	GND	
B26	GND	GND	
B27	PCIE_TXP21	DIFF	
B28	PCIE_TXN21	DIFF	
B29	GND	GND	

Pin	Pin Name	Signal Type	Signal Level
B30	NC		
B31	PRSENT	I/O	
B32	GND	GND	

2.5.2 HDMI Port (CN3)

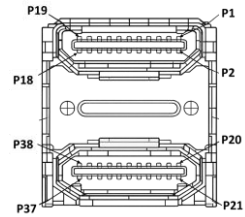
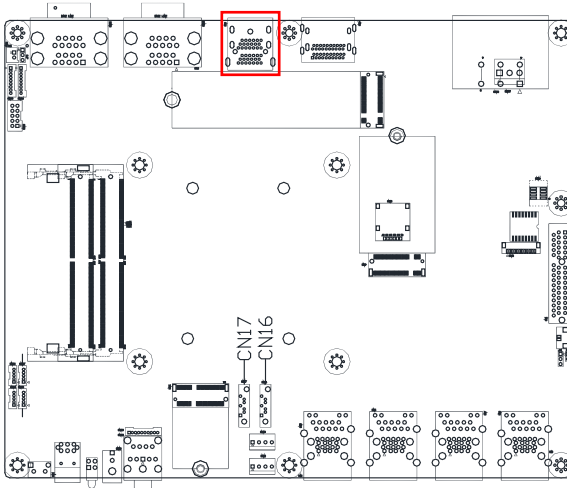

Pin	Pin Name	Signal Type	Signal Level
P1	HDMI1_DATA2_P	DIFF	
P2	GND	GND	
P3	HDMI1_DATA2_N	DIFF	
P4	HDMI1_DATA1_P	DIFF	
P5	GND	GND	
P6	HDMI1_DATA1_N	DIFF	
P7	HDMI1_DATA0_P		
P8	GND	GND	
P9	HDMI1_DATA0_n		
P10	HDMI1_CLK_P	DIFF	
P11	GND	GND	
P12	HDMI1_CLK_N	DIFF	
P13	CEC		3.3V
P14	NC		
P15	HDMI1_SCL		
P16	HDMI1_SDA		
P17	GND	GND	

Pin	Pin Name	Signal Type	Signal Level
P18	+V5S_HDMI_CON	PWR	5V
P19	HDMI1_HPD		5V
P20	HDMI2_DATA2_P		
P21	GND	GND	
P22	HDMI2_DATA2_N		
P23	HDMI2_DATA1_P		
P24	GND	GND	
P25	HDMI2_DATA1_N		
P26	HDMI2_DATA0_P		
P27	GND	GND	
P28	HDMI2_DATA0_N		
P29	HDMI2_CLK_P		
P30	GND	GND	
P31	HDMI2_CLK_N		
P32	CEC		3.3V
P33	NC		
P34	HDMI2_SCL		
P35	HDMI2_SDA		
P36	GND	GND	
P37	+V5S_HDMI_CON		5V
P38	HDMI2_HPD		5V

2.5.3 Dual Display Port (CN4)

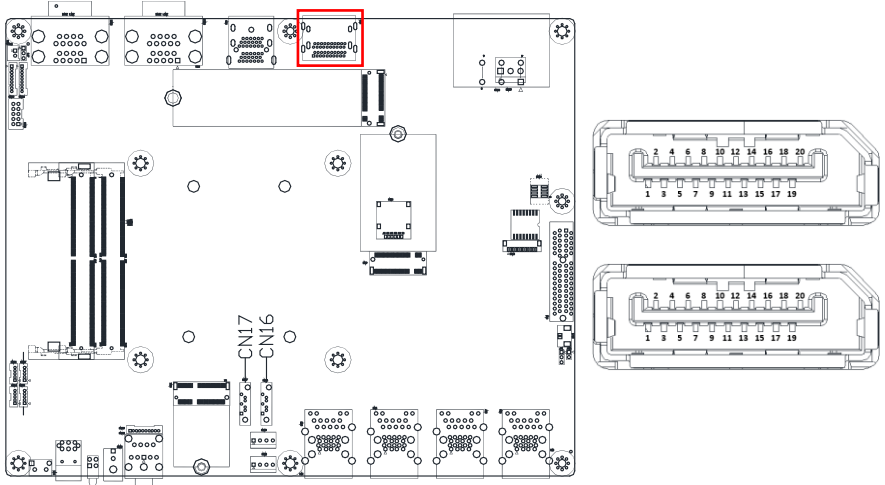

Pin	Pin Name	Signal Type	Signal Level
P1	DP1_DATA0 _P	DIFF	
P2	GND	GND	
P3	DP1_DATA0 _N	DIFF	
P4	DP1_DATA1 _P	DIFF	
P5	GND	GND	
P6	DP1_DATA1 _N	DIFF	
P7	DP1_DATA2 _P	DIFF	
P8	GND	GND	
P9	DP1_DATA1 _N	DIFF	
P10	DP1_DATA3 _P	DIFF	
P11	GND	GND	
P12	DP1_DATA3 _N	DIFF	
P13	CONFIG1		
P14	CONFIG2		
P15	DP1_AUX _P	DIFF	
P16	GND	GND	
P17	DP1_AUX _N	DIFF	
P18	DP1_HPD		
P19	RETURN		
P20	DP1_PWR	PWR	+3.3V
P21	DP2_DATA0 _P	DIFF	
P22	GND	GND	
P23	DP2_DATA0 _N	DIFF	
P24	DP2_DATA1 _P	DIFF	
P25	GND	GND	
P26	DP2_DATA1 _N	DIFF	
P27	DP2_DATA2 _P	DIFF	
P28	GND	GND	
P29	DP2_DATA1 _N	DIFF	
P30	DP2_DATA3 _P	DIFF	
P31	GND	GND	
P32	DP2_DATA3 _N	DIFF	
P33	CONFIG1		
P34	CONFIG2		
P35	DP2_AUX _P	DIFF	
P36	GND	GND	
P37	DP2_AUX _N	DIFF	
P38	DP2_HPD		
P39	RETURN		

Pin	Pin Name	Signal Type	Signal Level
P40	DP2_PWR	PWR	+3.3V

2.5.4 GbE LAN (RJ-45) + Dual USB 3.2 Connector (CN5)

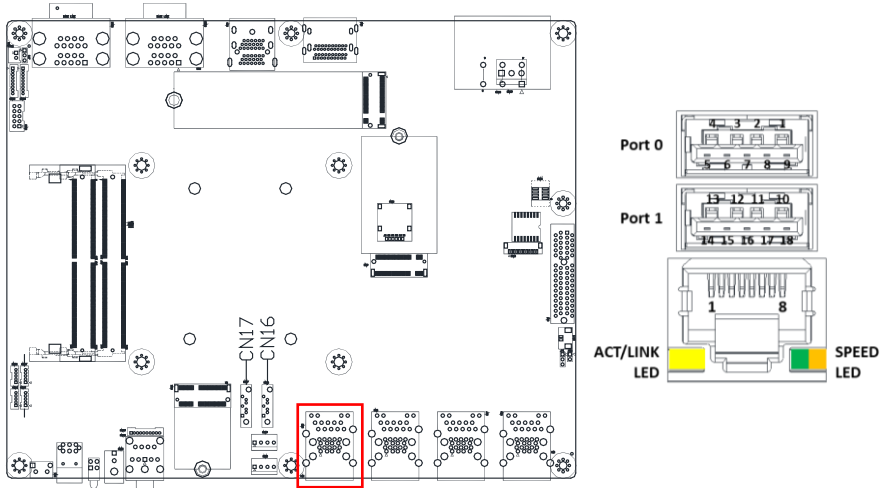

LAN

Pin	Signal	Signal Type	Signal Level
1	MDI0+	DIFF	
2	MDI0-	DIFF	
3	MDI1+	DIFF	
4	MDI2+	DIFF	
5	MDI2-	DIFF	
6	MDI1-	DIFF	
7	MDI3+	DIFF	
8	MDI3-	DIFF	

USB

Pin	Signal	Signal Type	Signal Level
1	+5VSB	PWR	+5V
2	USB1_D-	DIFF	
3	USB1_D+	DIFF	
4	GND	GND	
5	USB1_SSRX-	DIFF	
6	USB1_SSRX+	DIFF	
7	GND	GND	

USB			
Pin	Signal	Signal Type	Signal Level
8	USB1_SSTX-	DIFF	
9	USB1_SSTX+	DIFF	
10	+5VSB	PWR	+5V
11	USB2_D-	DIFF	
12	USB2_D+	DIFF	
13	GND	GND	
14	USB2_SSRX-	DIFF	
15	USB2_SSRX+	DIFF	
16	GND	GND	
17	USB2_SSTX-	DIFF	
18	USB2_SSTX+	DIFF	

2.5.5 2.5GbE LAN (RJ-45) + Dual USB 3.2 Connector (CN6)

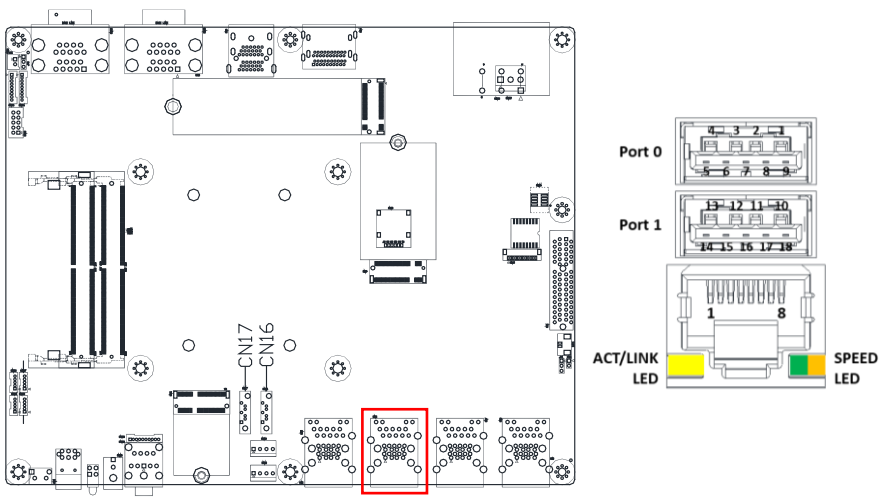

LAN			
Pin	Signal	Signal Type	Signal Level
1	MDI0+	DIFF	
2	MDI0-	DIFF	
3	MDI1+	DIFF	
4	MDI2+	DIFF	
5	MDI2-	DIFF	
6	MDI1-	DIFF	
7	MDI3+	DIFF	

LAN			
Pin	Signal	Signal Type	Signal Level
8	MDI3-	DIFF	
USB			
Pin	Signal	Signal Type	Signal Level
1	+5VSB	PWR	+5V
2	USB3_D-	DIFF	
3	USB3_D+	DIFF	
4	GND	GND	
5	USB3_SSRX-	DIFF	
6	USB3_SSRX+	DIFF	
7	GND	GND	
8	USB3_SSTX-	DIFF	
9	USB3_SSTX+	DIFF	
10	+5VSB	PWR	+5V
11	USB4_D-	DIFF	
12	USB4_D+	DIFF	
13	GND	GND	
14	USB4_SSRX-	DIFF	
15	USB4_SSRX+	DIFF	
16	GND	GND	
17	USB4_SSTX-	DIFF	
18	USB4_SSTX+	DIFF	

2.5.6 GbE LAN (RJ-45) + Dual USB 3.2 Connector (CN7)

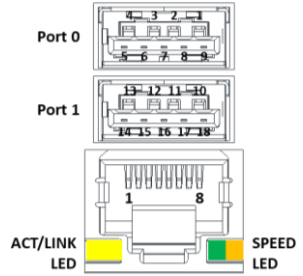
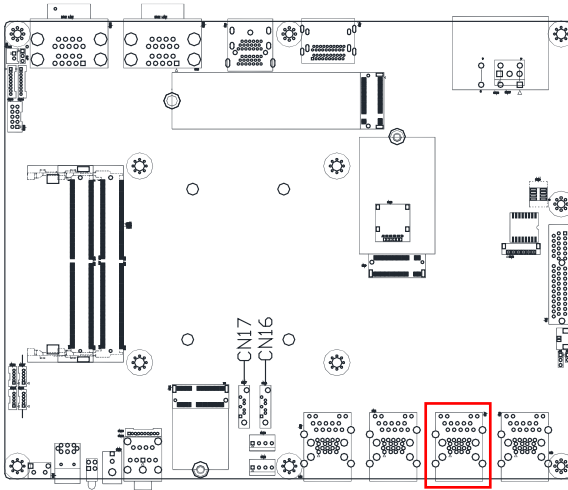

LAN			
Pin	Signal	Signal Type	Signal Level
1	MDI0+	DIFF	
2	MDI0-	DIFF	
3	MDI1+	DIFF	
4	MDI2+	DIFF	
5	MDI2-	DIFF	
6	MDI1-	DIFF	
7	MDI3+	DIFF	
8	MDI3-	DIFF	

USB			
Pin	Signal	Signal Type	Signal Level
1	+5VSB	PWR	+5V
2	USB5_D-	DIFF	
3	USB5_D+	DIFF	
4	GND	GND	
5	USB5_SSRX-	DIFF	
6	USB5_SSRX+	DIFF	
7	GND	GND	
8	USB5_SSTX-	DIFF	
9	USB5_SSTX+	DIFF	
10	+5VSB	PWR	+5V
11	USB6_D-	DIFF	

USB			
Pin	Signal	Signal Type	Signal Level
12	USB6_D+	DIFF	
13	GND	GND	
14	USB6_SSRX-	DIFF	
15	USB6_SSRX+	DIFF	
16	GND	GND	
17	USB6_SSTX-	DIFF	
18	USB6_SSTX+	DIFF	

2.5.7 GbE LAN (RJ-45) + Dual USB 3.2 Connector (CN8)

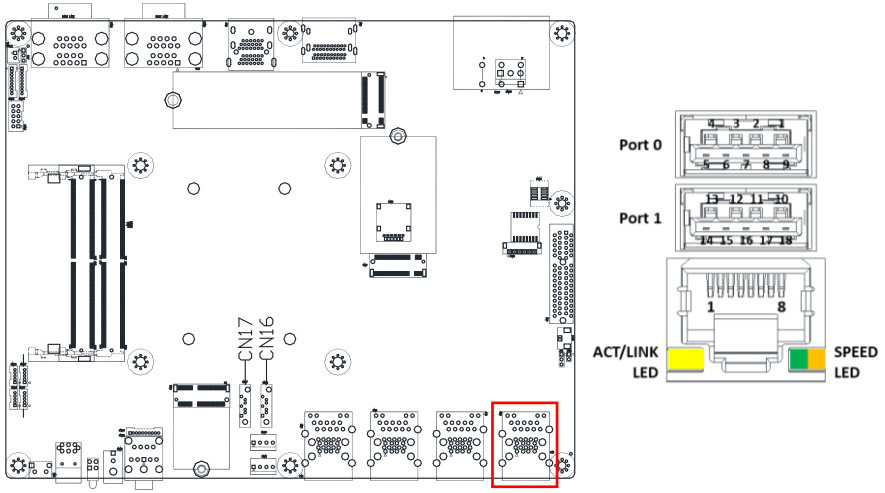

LAN			
Pin	Signal	Signal Type	Signal Level
1	MDI0+	DIFF	
2	MDI0-	DIFF	
3	MDI1+	DIFF	
4	MDI2+	DIFF	
5	MDI2-	DIFF	
6	MDI1-	DIFF	
7	MDI3+	DIFF	
8	MDI3-	DIFF	

USB			
Pin	Signal	Signal Type	Signal Level
1	+5VSB	PWR	+5V

USB			
Pin	Signal	Signal Type	Signal Level
2	USB7_D-	DIFF	
3	USB7_D+	DIFF	
4	GND	GND	
5	USB7_SSRX-	DIFF	
6	USB7_SSRX+	DIFF	
7	GND	GND	
8	USB7_SSTX-	DIFF	
9	USB7_SSTX+	DIFF	
10	+5VSB	PWR	+5V
11	USB8_D-	DIFF	
12	USB8_D+	DIFF	
13	GND	GND	
14	USB8_SSRX-	DIFF	
15	USB8_SSRX+	DIFF	
16	GND	GND	
17	USB8_SSTX-	DIFF	
18	USB8_SSTX+	DIFF	

2.5.8 M.2 3052 B-Key Slot (CN9)

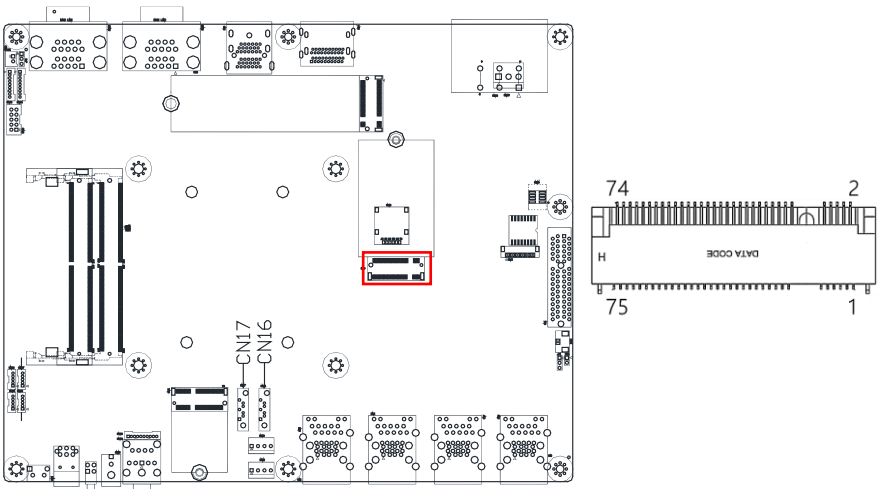

Pin	Pin Name	Signal Type	Pin	Pin Name	Signal Type	Signal Level
1	NC		2	+3.3V	PWR	+3.3V

Pin	Pin Name	Signal Type	Pin	Pin Name	Signal Type	Signal Level
3	GND	GND	4	+3.3V	PWR	+3.3V
5	GND	GND	6	CARD_PWR_OFF_N	OUT	+3.3V
7	USB_2.0_P		8	W_DISABLE	IN	+3.3V
9	USB_2.0_N		10	NC		
11	GND	GND				
			20	NC		
21	NC		22	NC		
23	NC		24	NC		
25	NC		26	NC		
27	GND	GND	28	NC		
29	USB3_RXN		30	UIM_RST		
31	USB3_RXP		32	UIM_CLK		
33	GND	GND	34	UIM_DATA		
35	USB3_TXN		36	UIM_PWR		
37	USB3_TXP		38	NC		
39	GND	GND	40	NC		
41	PCIE_RXN		42	NC		
43	PCIE_RXP		44	NC		
45	GND	GND	46	NC		
47	PCIE_TXN		48	NC		
49	PCIE_TXP		50	RESET#	IN	+3.3V
51	GND	PWR	52	CLKREQ#	OUT	+3.3V
53	PCIE_M.2_CLK#	OUT	54	WAKE#	OUT	+3.3V
55	PCIE_M.2_CLK	OUT	56	NC		
57	GND	GND	58	NC		
59	NC		60	NC		
61	NC		62	NC		
63	NC		64	NC		
65	NC		66	NC		
67	RESET#		68	SUSCLK		
69	NC		70	+3.3V	PWR	+3.3V
71	GND	GND	72	+3.3V	PWR	+3.3V
73	GND	GND	74	+3.3V	PWR	+3.3V
75	GND	GND				

2.5.9 SIM Slot (CN10)

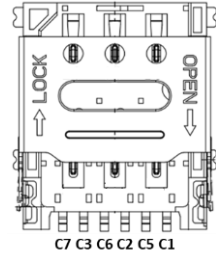
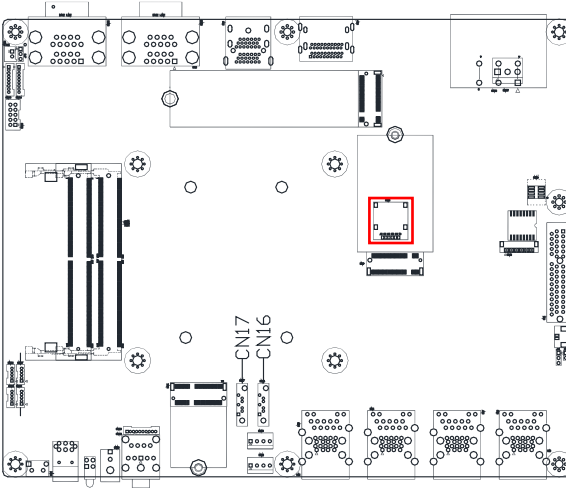

Pin	Pin Name	Signal Type	Signal Level
C1	UIM_PWR	PWR	
C2	UIM_RESET	IN	
C3	UIM_CLK	IN	
C5	GND	GND	
C6	NA	NA	
C7	UIM_DATA	I/O	

2.5.10 M.2 2230 E-Key Slot (CN11)

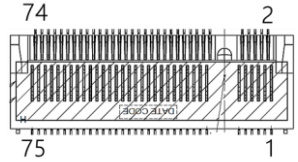
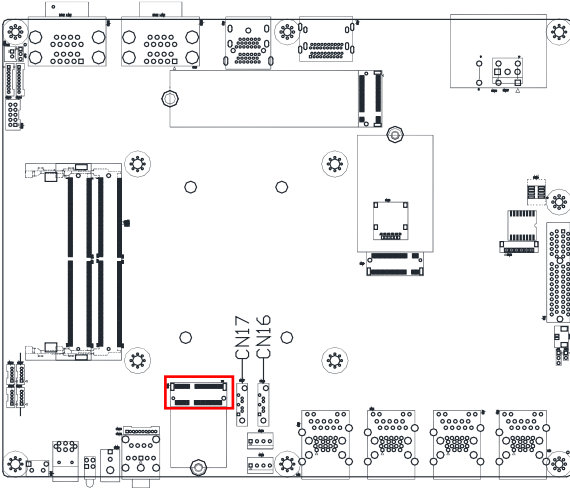

Standard specification.

2.5.11 Remote Button Connector (CN13)

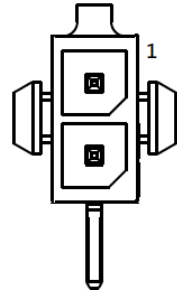
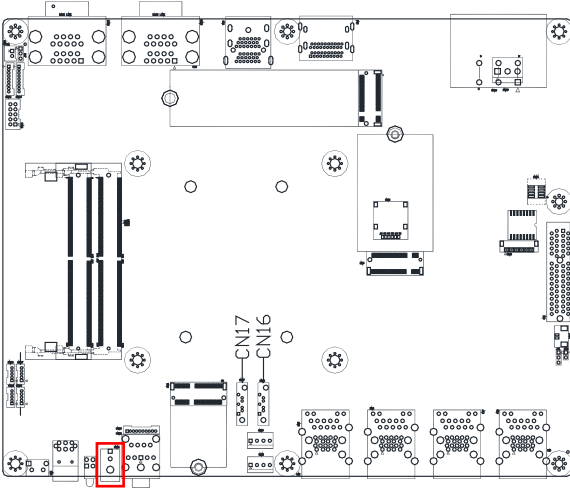

Pin	Pin Name	Signal Type	Signal Level
1	PWR_BUTTON	IN	Signal
2	GND	GND	GND

2.5.12 SPI Flash Port (CN14)

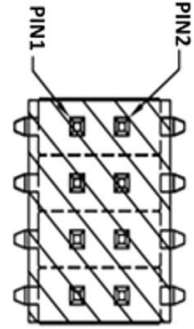
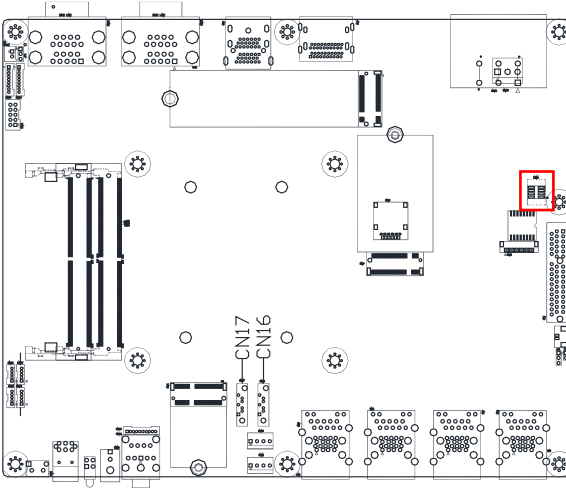

Pin	Pin Name	Signal Type	Signal Level
1	SPI_MISO	OUT	
2	GND	GND	
3	SPI_CLK	IN	
4	+3.3VSB	PWR	+3.3V
5	SPI_MOSI	IN	
6	SPI_CS	IN	
7	NC		
8	NC		

2.5.13 Debug Card Connector (CN15)

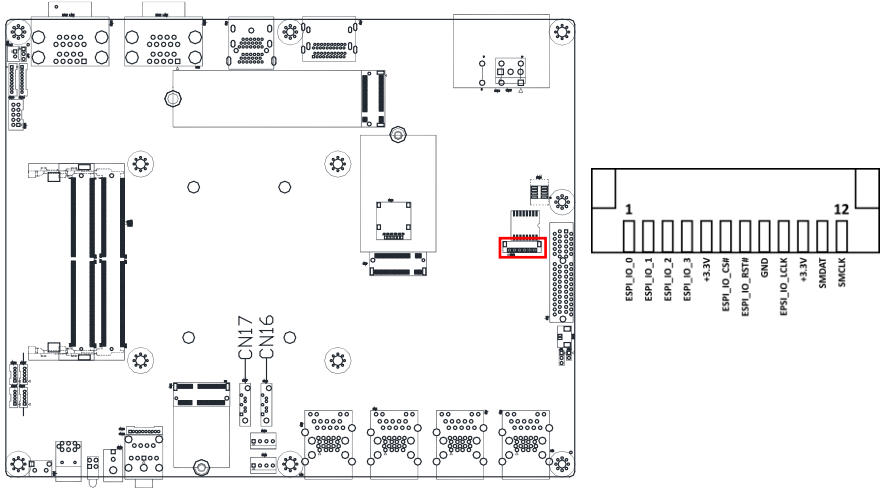

Pin	Pin Name	Signal Type	Signal Level
1	ESPI_IO_0	I/O	+1.8V
2	ESPI_IO_1	I/O	+1.8V
3	ESPI_IO_2	I/O	+1.8V
4	ESPI_IO_3	I/O	+1.8V
5	+3.3V	PWR	+3.3VS
6	ESPI_IO_CS#	IN	
7	ESPI_IO_RST#	IN	
8	GND	GND	
9	EPSI_IO_LCLK	IN	
10	+3.3V	PWR	+3.3VA
11	SMDAT	I/O	
12	SMCLK	IN	

2.5.14 SATA Port 1/Port 2 (CN16/CN17)

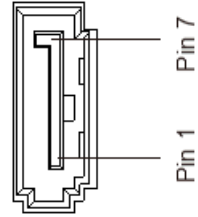
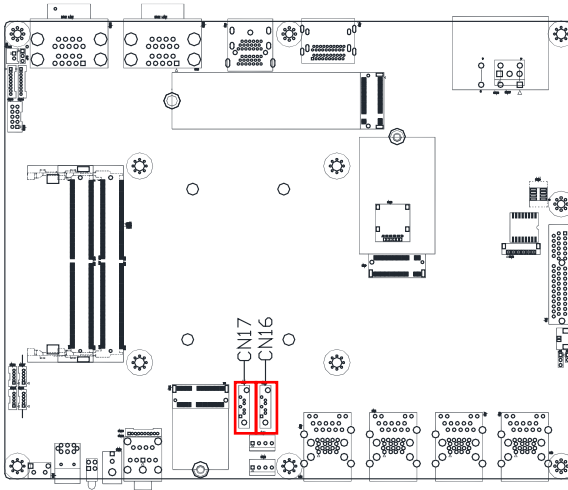

Pin	Pin Name	Signal Type	Signal Level
1	GND	GND	
2	SATA_TX+	DIFF	
3	SATA_TX-	DIFF	
4	GND	GND	
5	SATA_RX-	DIFF	
6	SATA_RX+	DIFF	
7	GND	GND	

2.5.15 SATA Power Connector (CN18/CN19)

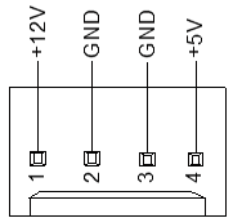
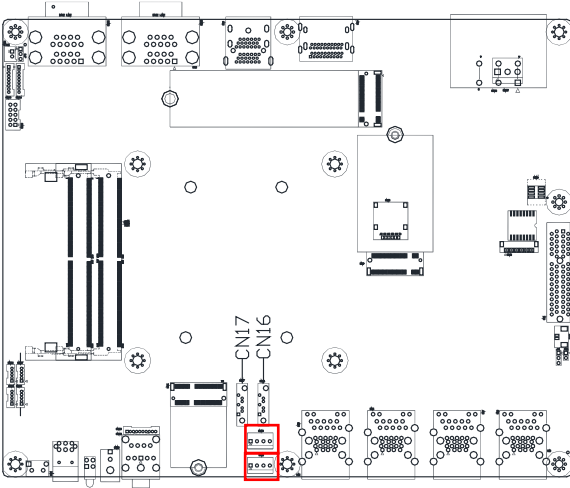

Pin	Pin Name	Signal Type	Signal Level
1	+12V	PWR	+12V
2	GND	GND	
3	GND	GND	
4	+5V	PWR	+5V

2.5.16 DIO (Wafer Box) (CN20)

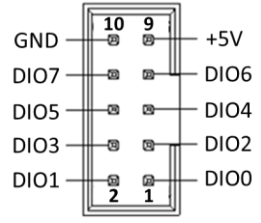
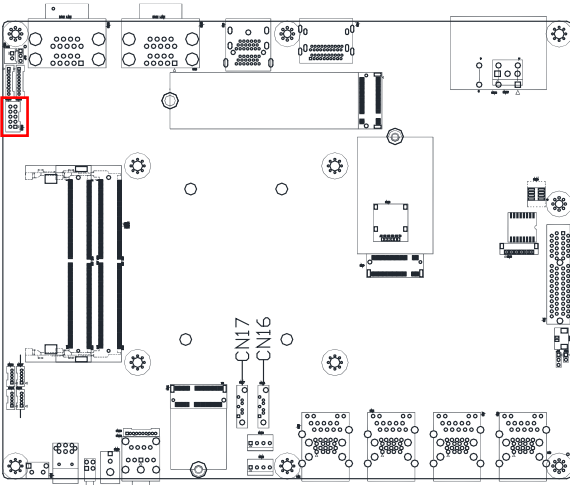

Pin	Pin Name	Signal Type	Signal Level
1	DIO0	I/O	+5V
2	DIO1	I/O	+5V
3	DIO2	I/O	+5V
4	DIO3	I/O	+5V
5	DIO4	I/O	+5V
6	DIO5	I/O	+5V
7	DIO6	I/O	+5V
8	DIO7	I/O	+5V
9	+5V	PWR	+5V
10	GND	GND	

2.5.17 Dual COM Connector (RS-232/422/485) (CN22/CN23)

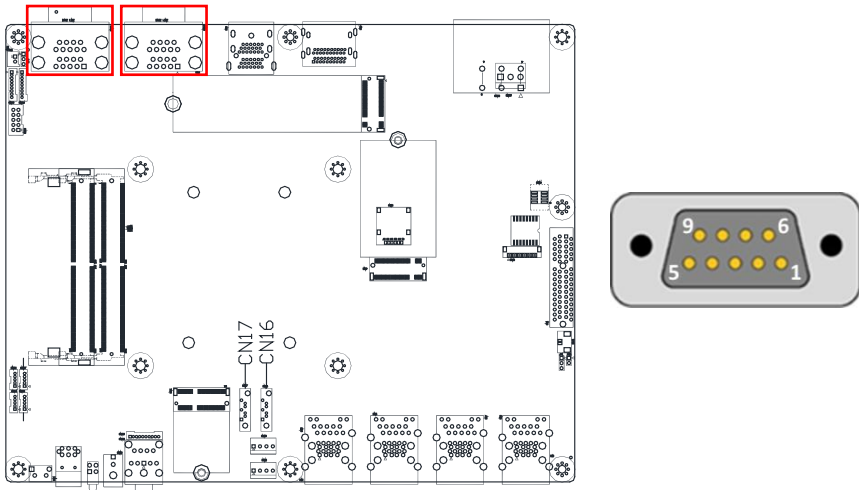

Pin	Pin Name	Signal Type	RS-422	RS-485
1	DCD	IN	RS422_TX-	RS485_D-
2	RX	IN	RS422_TX+	RS485_D+
3	TX	OUT	RS422_RX+	
4	DTR	OUT	RS422_RX-	
5	GND	GND		
6	DSR	IN		
7	RTS	OUT		
8	CTS	IN		
9	R11	IN		

2.5.18 USB 2.0 Wafer Box (CN24/CN25/CN26/CN27)

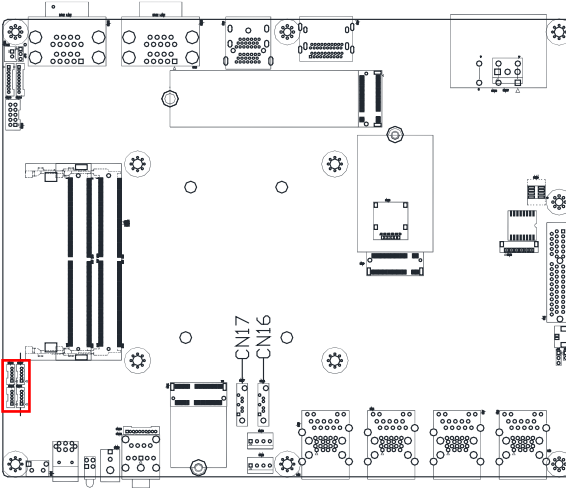

Pin	Pin Name	Signal Type	Signal Level
1	+5V	GND	+5V
2	USB D-	DIFF	
3	USB D+	DIFF	
4	GND	GND	
5	GND	GND	

2.5.19 Audio Connector (CN28)

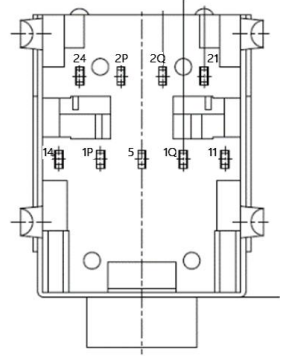
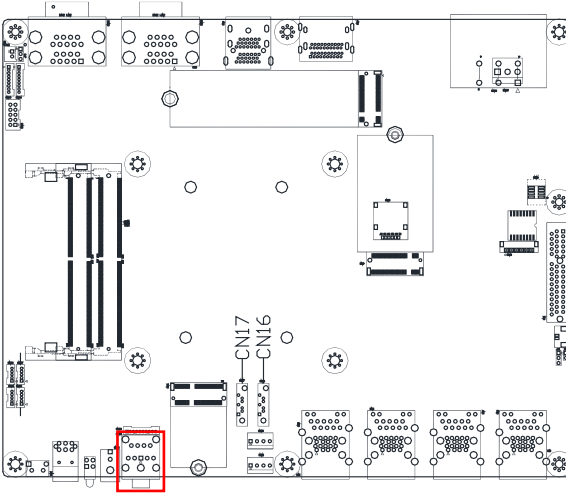

Pin	Pin Name	Signal Type	Signal Level
5	AUD_GND	GND	
24	LOUT_L	OUT	
21	LOUT_R	OUT	
2P	HP_DET_3	IN	
2Q	HP_DET_4	IN	
14	MIC_L	IN	
11	MIC_R	IN	
1P	HP_DET_1	IN	
1Q	HP_DET2	IN	

2.5.20 Audio Wafer (10P pitch:1.25mm, Optional) (CN29)

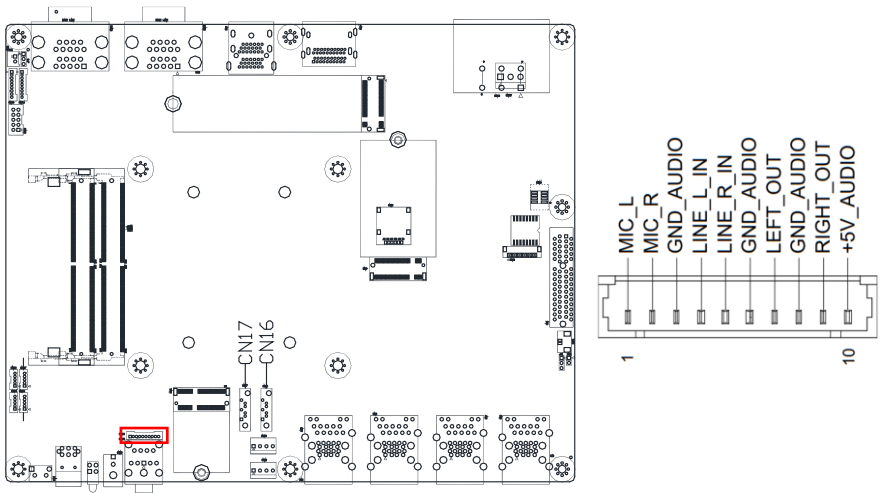

Pin	Pin Name	Signal Type	Signal Level
1	MIC_L	IN	
2	MIC_R	IN	
3	GND_AUDIO	GND	
4	LINE_L_IN	IN	
5	LINE_R_IN	IN	
6	GND_AUDIO	GND	
7	LEFT_OUT	OUT	
8	GND_AUDIO	GND	
9	RIGHT_OUT	OUT	
10	+5V_AUDIO	PWR	+5V

2.5.21 Power Input Connector (CN30)

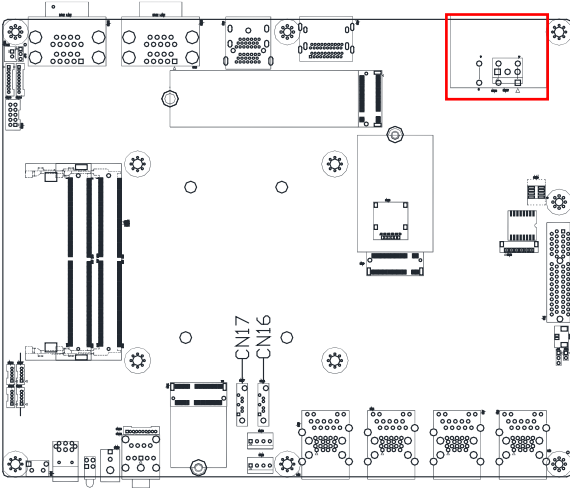

PIN1 PIN2 PIN3

Pin	Pin Name	Signal Type	Signal Level
1	VIN	PWR	+12V ~ +24V
2	GND	GND	
3	GND_EARTH		

2.5.22 M.2 2280 M-Key Slot (CN31)

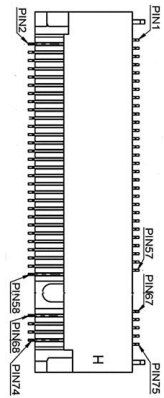
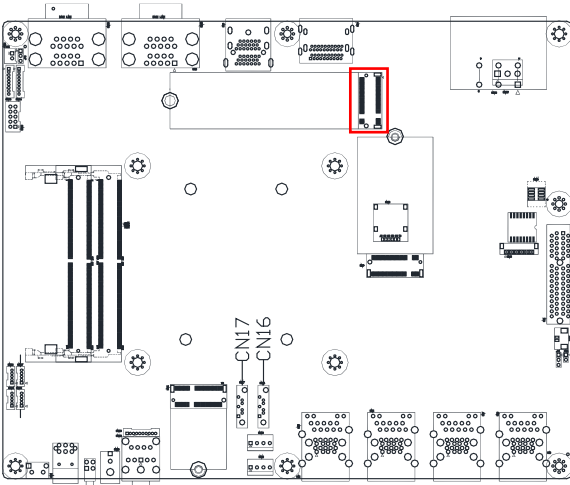

Pin	Pin Name	Signal Type	Pin	Pin Name	Signal Type	Signal Level
1	GND	GND	2	+3.3V	PWR	+3.3V
3	GND	GND	4	+3.3V	PWR	+3.3V
5	PCIE_RXN0	IN	6	CARD_PWR_OFF_N	OUT	+3.3V
7	PCIE_RXP0	IN	8	NC		
9	GND	GND	10	NC		
11	PCIE_TXN0	OUT	12	+3.3V	PWR	+3.3V
13	PCIE_TXP0	OUT	14	+3.3V	PWR	+3.3V
15	GND	PWR	16	+3.3V	PWR	+3.3V
17	PCIE_RXN1	IN	18	+3.3V	PWR	+3.3V
19	PCIE_RXP1	IN	20	NC		
21	GND	PWR	22	NC		
23	PCIE_TXN1	OUT	24	NC		
25	PCIE_TXP1	OUT	26	NC		
27	GND	PWR	28	NC		
29	PCIE_RXN2	IN	30	NC		
31	PCIE_RXP2	IN	32	NC		
33	GND	GND	34	NC		
35	PCIE_TXN2	OUT	36	NC		
37	PCIE_TXP2	OUT	38	DEVSLP	IN	+3.3V
39	GND	GND	40	SMB_CLK_M2		+1.8V
41	PCIE_RXP3	IN	42	SMB_DATA_M2		+1.8V
43	PCIE_RXN3	IN	44	NC		
45	GND	GND	46	NC		
47	PCIE_TXN3	OUT	48	NC		
49	PCIE_TXP3	OUT	50	RESET#	IN	+3.3V
51	GND	PWR	52	CLKREQ#	OUT	+3.3V
53	PCIE_M.2_CLK#	OUT	54	WAKE#	OUT	+3.3V
55	PCIE_M.2_CLK	OUT	56	NC		
57	GND	GND	58	NC		
67	NC		68	NC		
69	NC		70	+3.3V	PWR	+3.3V
71	GND	GND	72	+3.3V	PWR	+3.3V
73	GND	GND	74	+3.3V	PWR	+3.3V
75	GND	GND				

2.5.23 Fan Connector (CN32)

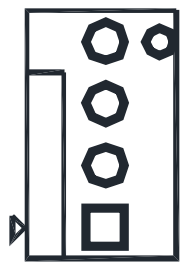
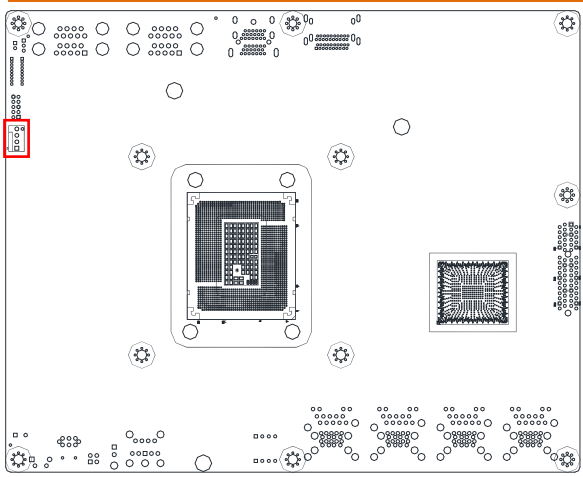

Pin	Pin Name	Signal Type	Signal Level
1	GND	GND	
2	+V12S	PWR	+12V
3	FAN_PWM	OUT	
4	FAN_CTL	OUT	

2.5.24 COM Port 5 (Wafer Box, Optional) (CN33)

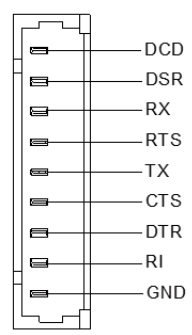
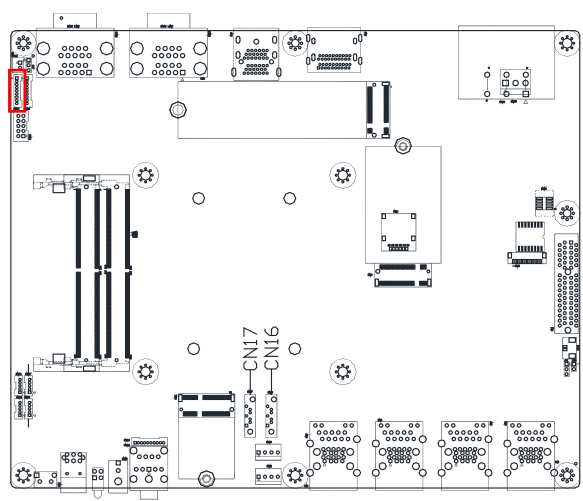

Pin	Pin Name	Signal Type	RS-422	RS-485
1	DCD	IN	RS422_TX-	RS485_D-
2	DSR	IN		
3	RX	IN	RS422_TX+	RS485_D+
4	RTS	OUT		
5	TX	OUT	RS422_RX+	
6	CTS	IN		
7	DTR	OUT	RS422_RX-	
8	RI	IN		
9	GND	GND		

2.5.25 COM Port 6 (Wafer Box, Optional) (CN34)

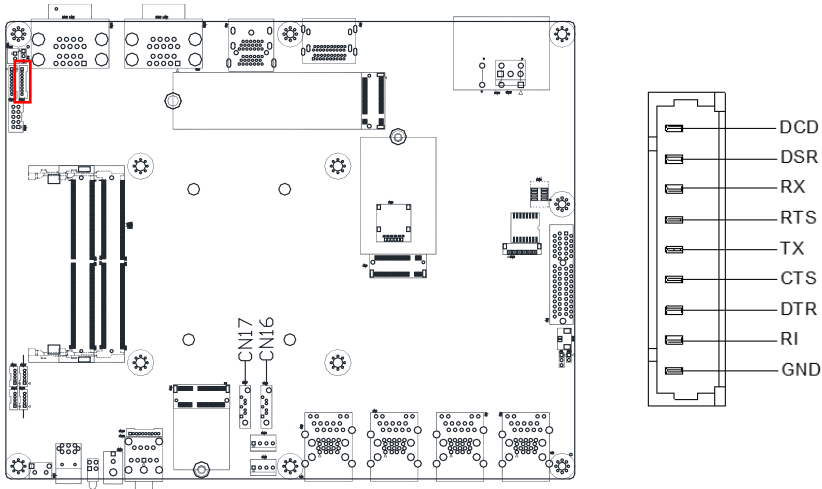

Pin	Pin Name	Signal Type	RS-422	RS-485
1	DCD	IN	RS422_TX-	RS485_D-
2	DSR	IN		
3	RX	IN	RS422_TX+	RS485_D+
4	RTS	OUT		
5	TX	OUT	RS422_RX+	
6	CTS	IN		
7	DTR	OUT	RS422_RX-	
8	RI	IN		
9	GND	GND		

2.5.26 A1 SKU Riser Card

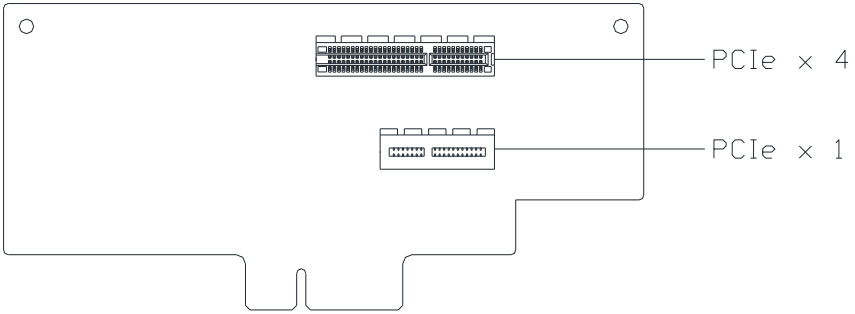

2.5.27 A2 SKU Riser Card

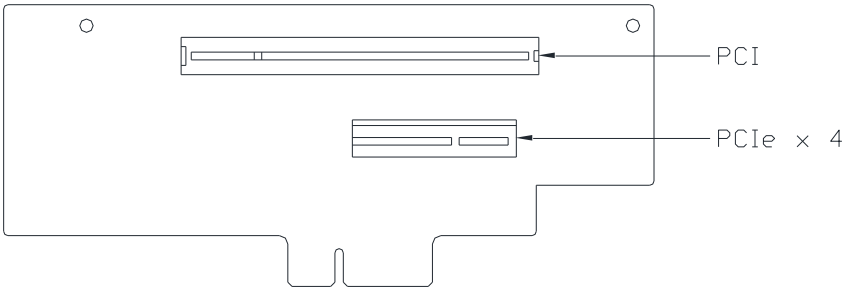

2.6 CPU Installation

1. Remove the three (3) screws from both the front and rear chassis panels (a total of six ((6)) screws), then lift the cover to expose bottom-side of the system motherboard.

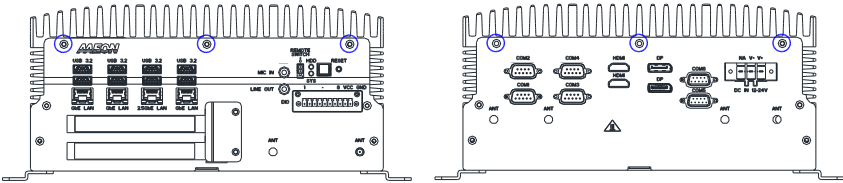

2. Insert the CPU into the socket as shown, ensuring it is covered with a thermal pad prior to reassembly.

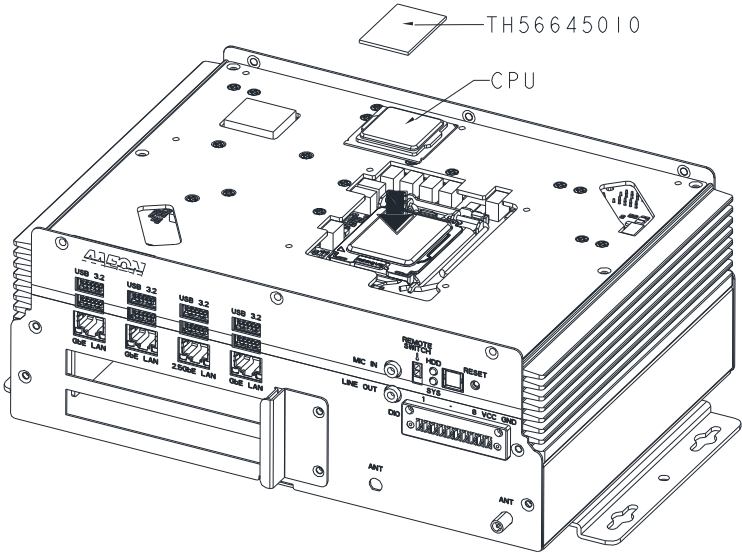

3. Once complete, reassemble the system, ensuring the system cover is secured with the screws removed during step 1.

2.7 RAM Module Installation

Before you begin, make sure you have the RAM module(s) you wish to install, along with thermal pads for each.

1. Remove the six (6) screws on the chassis bottom, as well as the four (4) screws used to affix the wall mount brackets to the system, then lift the cover to expose the system's PCB top side.

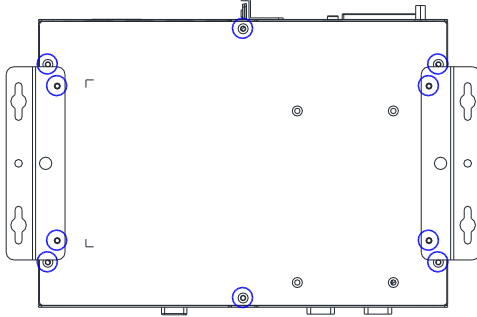

2. Prior to RAM module installation, add a thermal pad to the slot, then insert the notched end of the RAM module into the slot at approximately a 30° angle, gently pressing the module down firmly until the side tabs snap it into place.

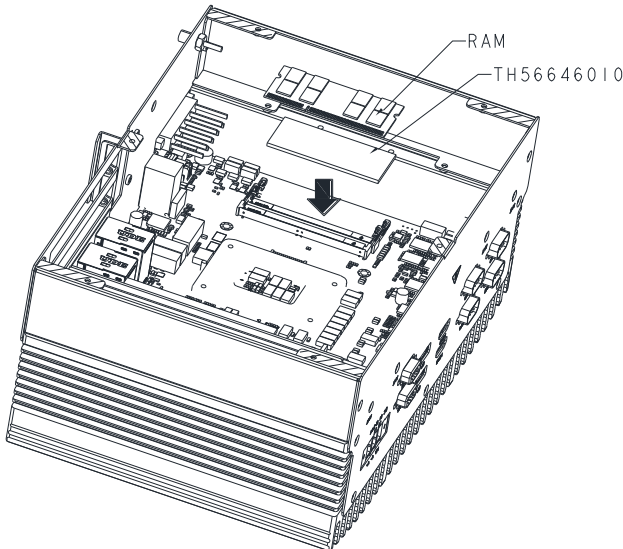

- Using the same technique, insert the second RAM module, followed by a second thermal pad, as shown.

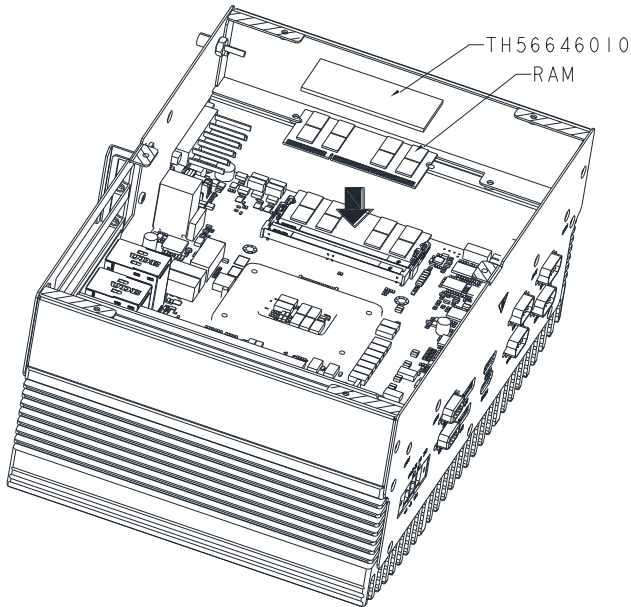

- To complete RAM installation, secure both modules using the RAM bracket, affixing it to the ridged edge of the chassis using the two (2) screws provided.

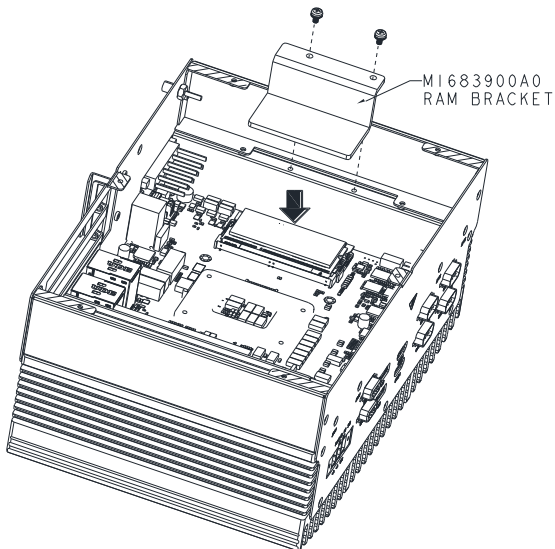

2.8 SATA Installation

1. If you have not already done so, remove the six (6) screws on the chassis bottom, as well as the four (4) screws used to affix the wall mount brackets to the system, then lift the cover to expose the system's PCB top side. See section 2.7 step 1 for details.
2. Install the 2.5" SATA drives into the SATA drive mount shown. Secure with four (4) screws on either side of the mount (a total of eight ((8)) screws).

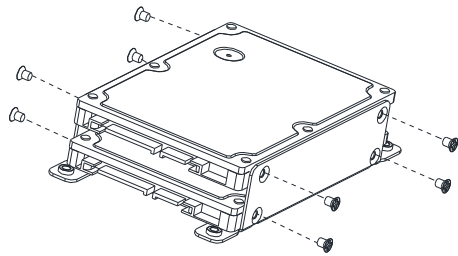
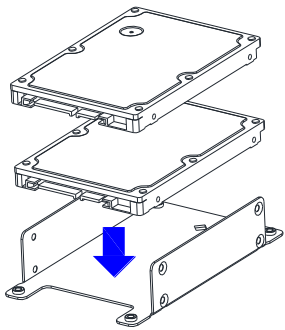

3. Position the mounted drive onto the system base plate, aligning the bracket holes with the threaded holes on the base, then secure the assembly using the indicated screws.

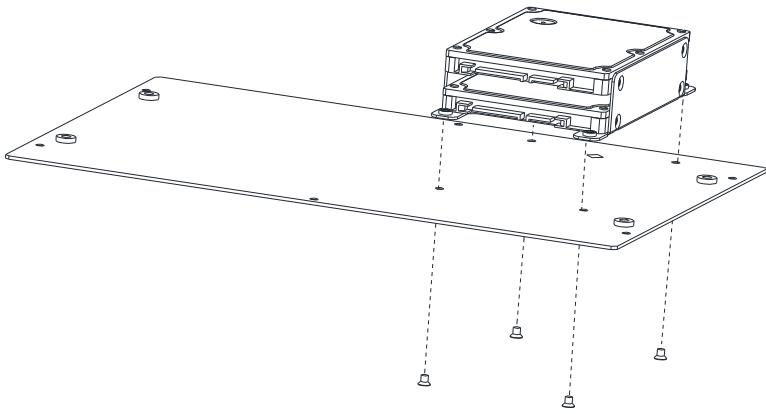

4. Connect one end of the SATA data cable to the drive, with the other end connected to the system motherboard.

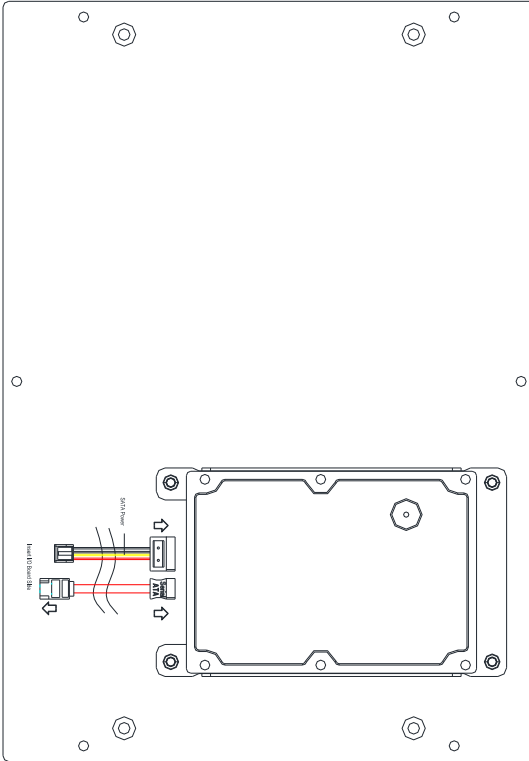

2.9 NVMe Installation

1. If you have not already done so, remove the six (6) screws on the chassis bottom, as well as the four (4) screws used to affix the wall mount brackets to the system, then lift the cover to expose the system's PCB top side. See section 2.7 step 1 for details.
2. Prior to NVMe installation, add a thermal pad to the slot, then insert your NVMe card into the slot using standard M.2 installation methods, followed by an additional thermal pad, as shown.

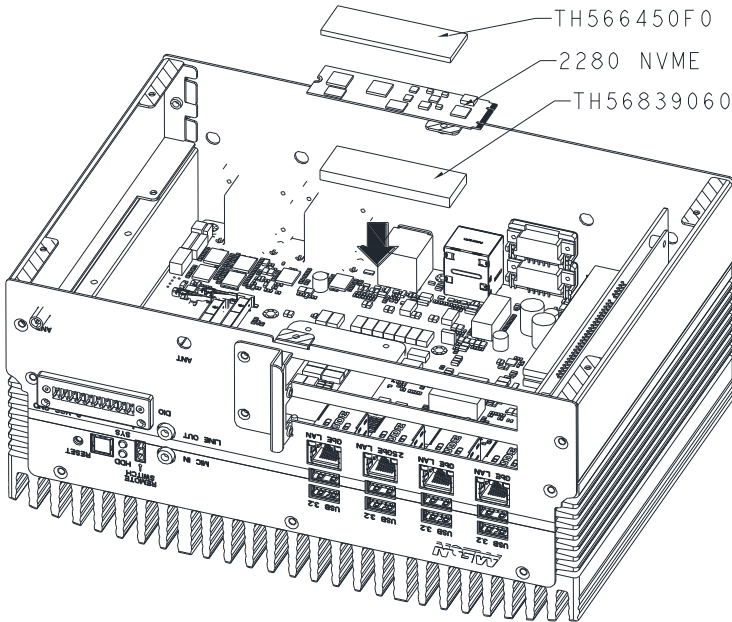

- To complete NVMe installation, affix the expansion card bracket to the motherboard using the two (2) screws, as shown.

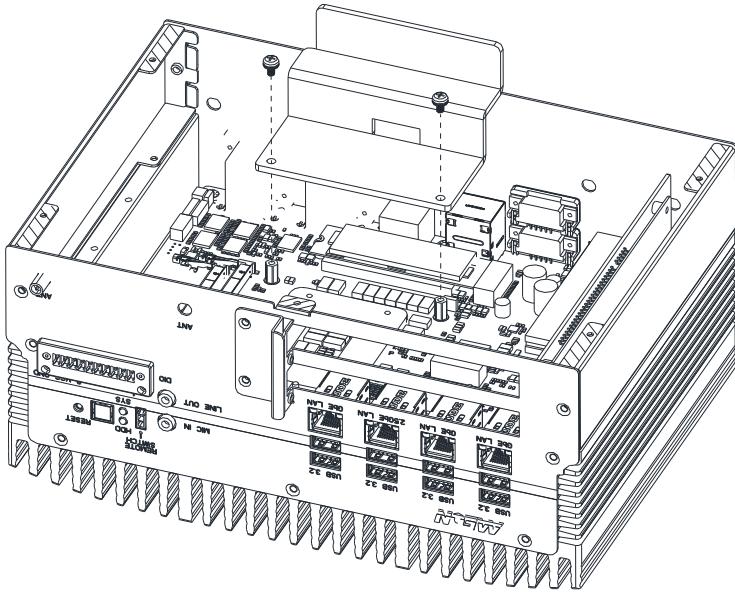

2.10 PCIe Card Installation

1. If you have not already done so, remove the six (6) screws on the chassis bottom, as well as the four (4) screws used to affix the wall mount brackets to the system, then lift the cover to expose the system's PCB top side. See section 2.7 step 1 for details.
2. Insert your PCIe card(s) into their respective slots, aligning the card's gold connector with the selected PCIe slot before pressing down firmly and evenly until the card is fully seated in the connector. Once the card is fully inserted, ensure the mounting bracket aligns with the corresponding chassis holes.

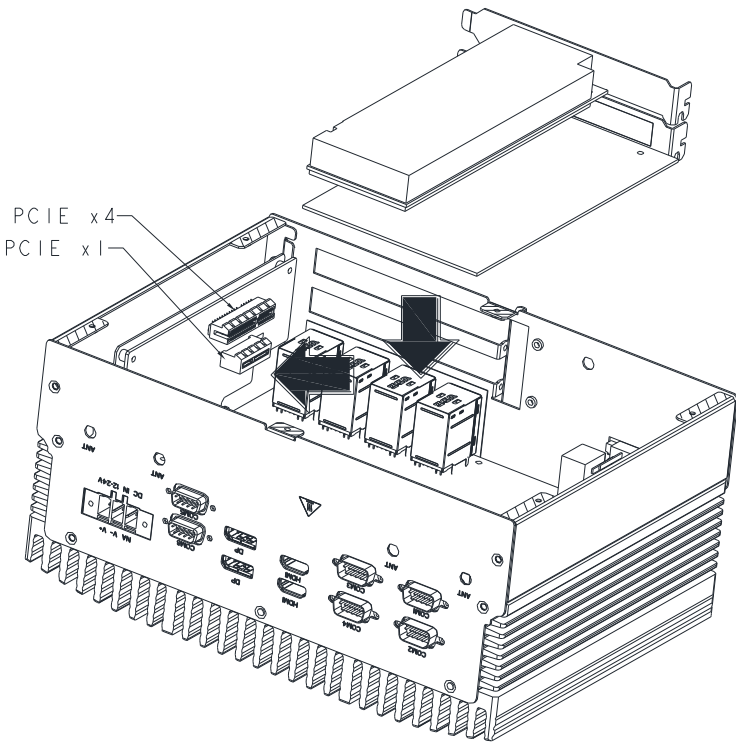

- Secure the retention bracket to the side wall of the chassis using the two (2) frame mounting screws, as shown below.

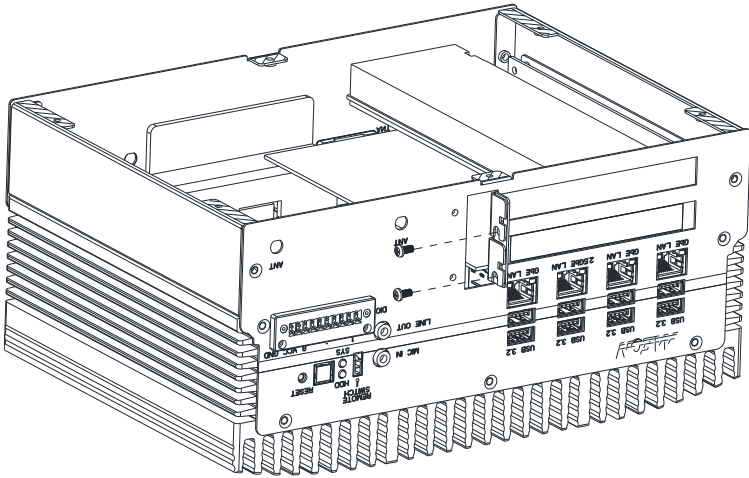

- Secure the PCIe card(s) to the bracket using the two (2) card retention screws, as shown.

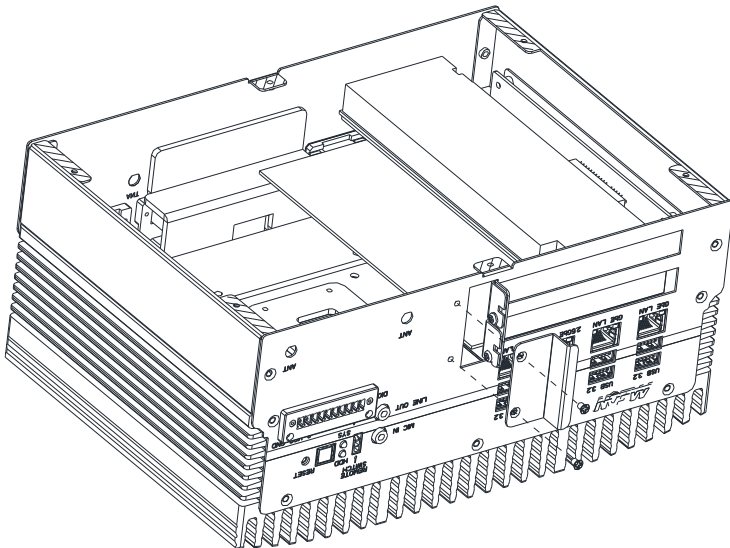

2.10 Wall Mount Bracket Installation

1. Align the holes on the brackets provided with the holes on the bottom panel of the system chassis. Secure each bracket using the two (2) screws provided (a total of four ((4)) screws, as shown).

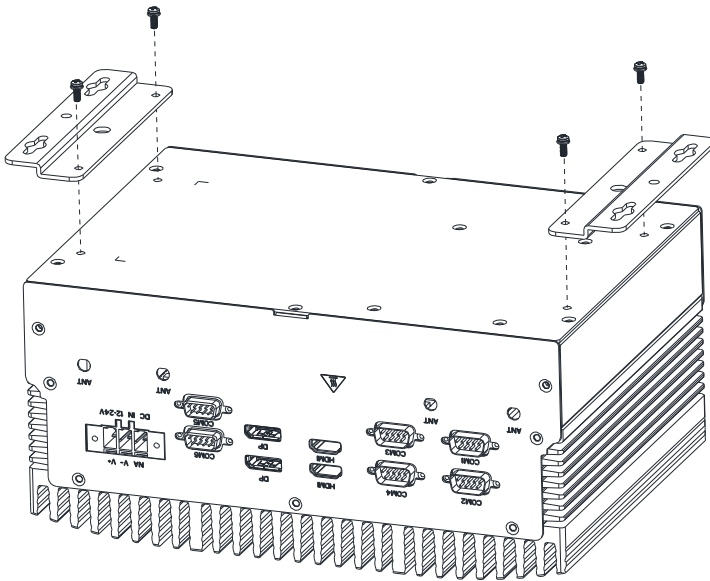

Chapter 3

AMI BIOS Setup

3.1 System Test and Initialization

The system uses certain routines to perform testing and initialization. If an error, fatal or non-fatal, is encountered, a few short beeps or an error message will be outputted. The board can usually continue the boot up sequence with non-fatal errors.

The system configuration verification routines check the current system configuration against the values stored in the CMOS memory. If they do not match, an error message will be outputted, in which case you will need to run the BIOS setup program to set the configuration information in memory.

There are three situations in which you will need to change the CMOS settings:

- You are starting your system for the first time
- You have changed your system's hardware
- The CMOS memory has lost power and the configuration information is erased

The system's CMOS memory uses a backup battery for data retention, which is to be replaced once emptied.

3.2 AMI BIOS Setup

The AMI BIOS ROM has a pre-installed Setup program that allows users to modify basic system configurations, which is stored in the battery-backed CMOS RAM and BIOS NVRAM so that the information is retained when the power is turned off.

To enter BIOS Setup, press or <F2> immediately while your computer is powering up.

The function for each interface can be found below.

Main – Date and time can be set here. Press <Tab> to switch between date elements

Advanced – Enable/ Disable boot option for legacy network devices

Chipset – Enable/ Disable system I/O device

Security – The setup administrator password can be set here

Boot – Enable/ Disable quiet Boot Option

Save & Exit – Save your changes and exit the program

MEBx – Intel® Management Engine BIOS Extension.

3.3 Setup Submenu: Main

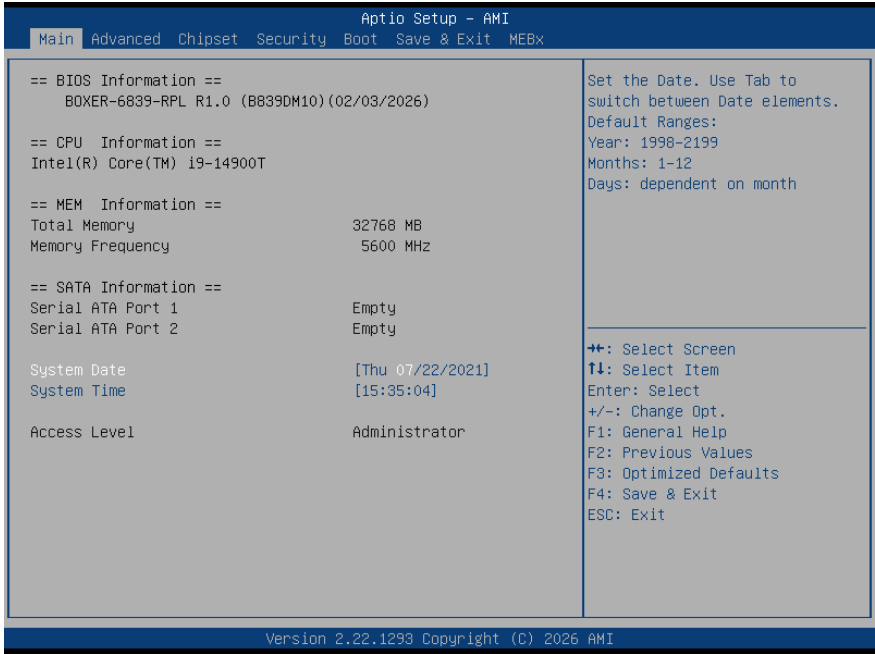

3.4 Setup Submenu: Advanced

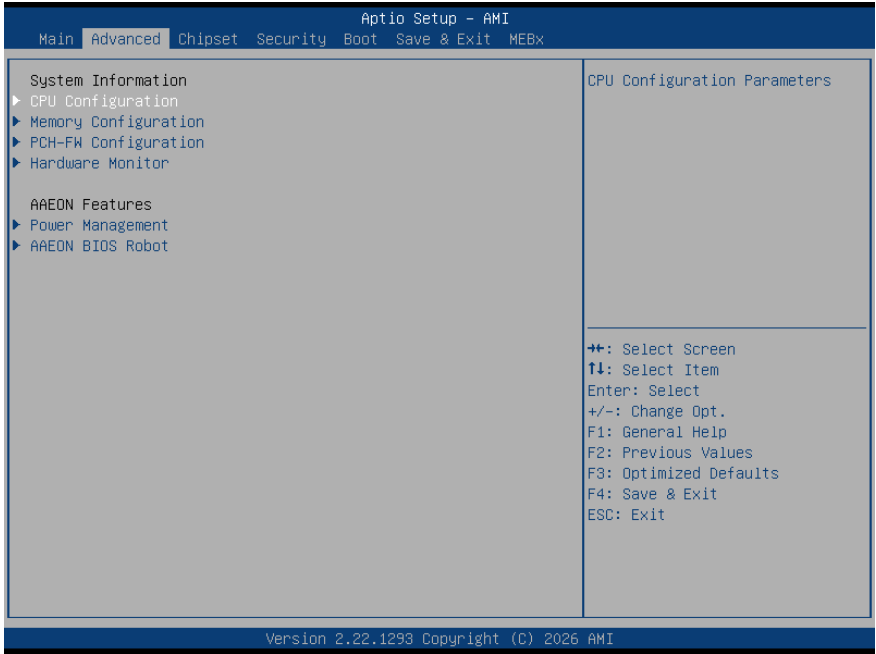

3.4.1 CPU Configuration

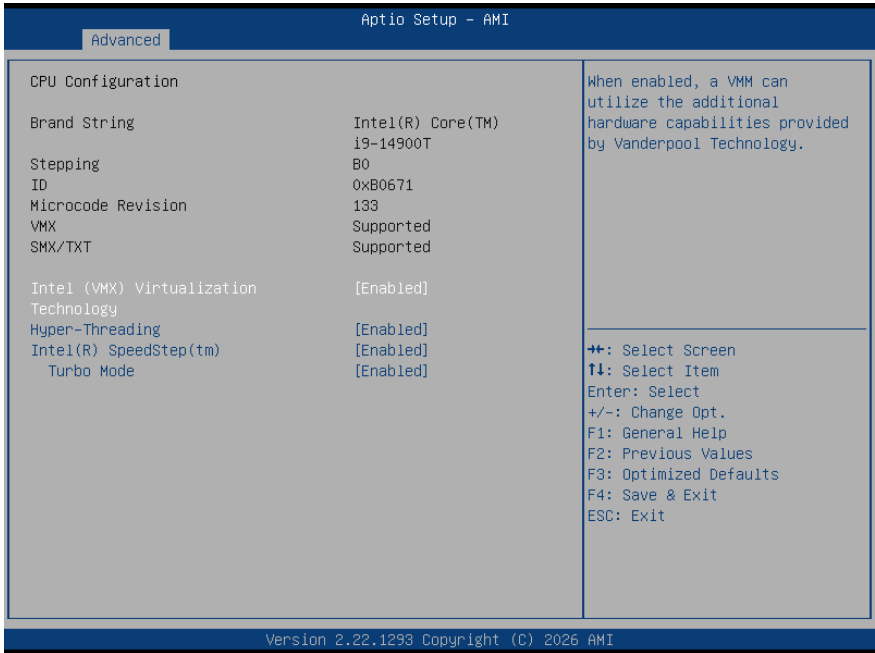

Options Summary		
Intel (VMX)Virtualization Technology	Disabled	
	Enabled	Optimal Default, Failsafe Default
When enabled, a VMM can utilize the additional hardware capabilities provided by Vanderpool Technology.		
Hyper-Threading	Disabled	
	Enabled	Optimal Default, Failsafe Default
Enable or Disable Hyper-Threading Technology		
Intel® SpeedStep™	Disabled	
	Enabled	Optimal Default, Failsafe Default
Allows more than two frequency ranges to be supported		
Turbo Mode	Disabled	
	Enabled	Optimal Default, Failsafe Default
Enable/Disable processor Turbo Mode (requires EMTTM enabled too). AUTO means enabled.		

3.4.2 Memory Configuration

The screenshot displays the 'Advanced' menu of the Aptio Setup - AMI BIOS. The 'Memory Configuration' section is active, showing the following details:

Total Memory	32768 MB
Memory Frequency	5600 MHz
tCL-tRCD-tRP-tRAS	46-45-45-90
MC 0 Ch 0 DIMM 0	Populated & Enabled
Size	16384 MB (DDR5)
MC 0 Ch 1 DIMM 0	Not Populated / Disabled
MC 1 Ch 0 DIMM 0	Populated & Enabled
Size	16384 MB (DDR5)
MC 1 Ch 1 DIMM 0	Not Populated / Disabled

Navigation legend:

- ⇧: Select Screen
- ⇩: Select Item
- Enter: Select
- +/-: Change Opt.
- F1: General Help
- F2: Previous Values
- F3: Optimized Defaults
- F4: Save & Exit
- ESC: Exit

Version 2.22.1293 Copyright (C) 2026 AMI

3.4.3 PCH-FW Configuration



Options Summary		
AMT BIOS Features	Enabled	Optimal Default, Failsafe Default
	Disabled	
<p>When disabled AMT BIOS Features are no longer supported and user is no longer able to access MEBx Setup.</p> <p>Note: This option does not disable Manageability Features in FW.</p>		

3.4.3.1 Firmware Update Configuration



Options Summary		
Me FW Image Re-Flash	Enabled	
	Disabled	Optimal Default, Failsafe Default
Enable/Disable Me FW Image Re-Flash function.		
FW Update	Enabled	
	Disabled	Optimal Default, Failsafe Default
Enable/Disable Me FW Update function.		

3.4.4 Hardware Monitor

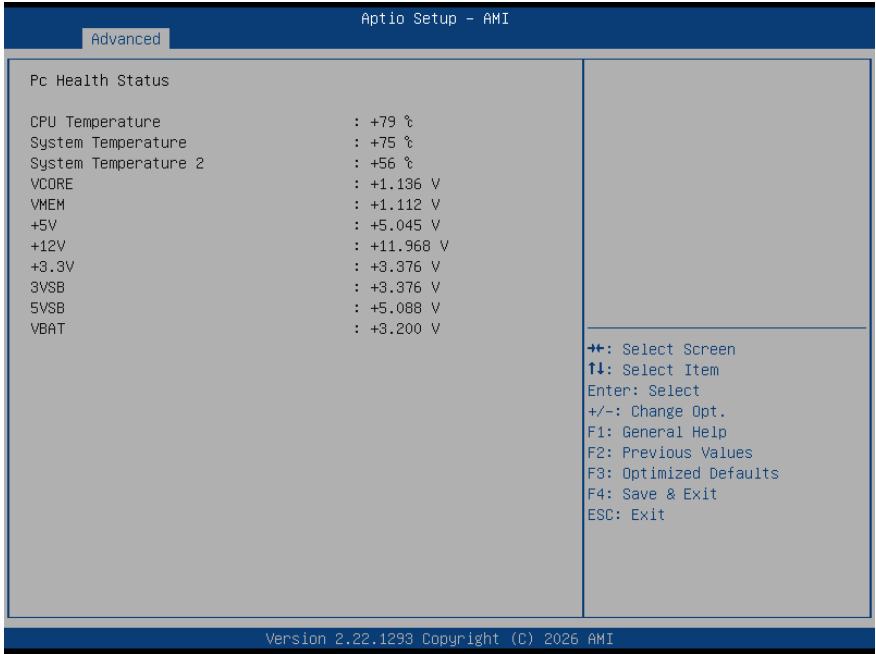

3.4.5 Power Management

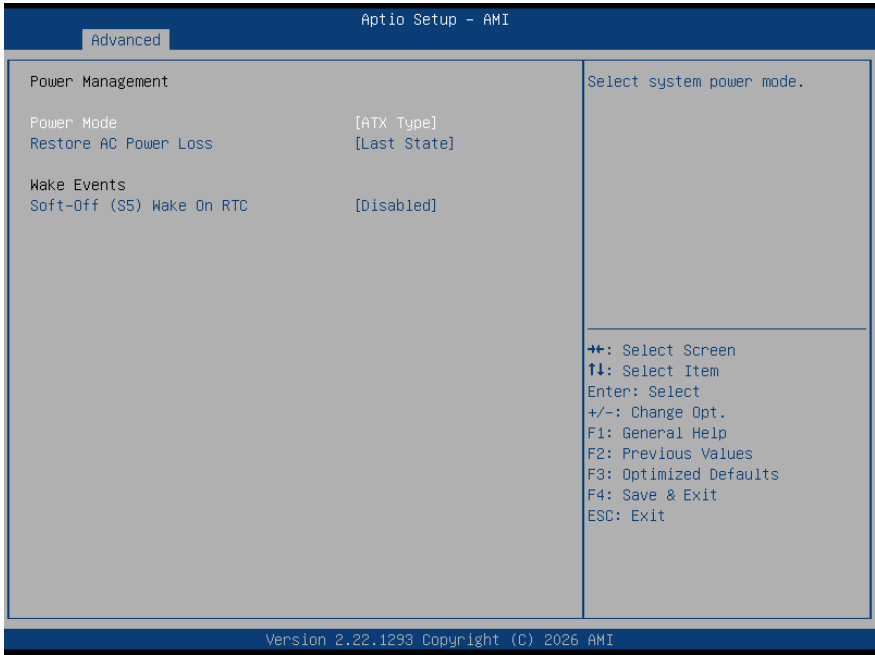

Options Summary		
Power Mode	ATX Type	Optimal Default, Failsafe Default
	AT Type	
Select system power mode.		
Restore AC Power Loss	Last State	Optimal Default, Failsafe Default
	Always On	
	Always Off	
Select power state when power is re-applied after a power failure.		
Soft-Off (S5) Wake On RTC	Disabled	Optimal Default, Failsafe Default
	By Date	
	By Weekday	
	Bypass	
By Date: System will wake on the day with hr::min::sec specified. By Weekday: System will wake on the enabled weekday with hr::min::sec specified. Bypass: BIOS will not control RTC wake function.		

3.4.6 AAEON BIOS Robot



Options Summary		
Sends watch dog before BIOS POST	Disabled	Optimal Default, Failsafe Default
	Enabled	
<p>Enabled – Robot set Watch Dog Timer (WDT) right after power on, before BIOS start POST process. And then Robot will clear WDT on completion of POST. WDT on completion of POST. WDT. WDT will reset system automatically if it is not cleared before its timer counts down to zero.</p>		
Sends watch dog before booting OS	Disabled	Optimal Default, Failsafe Default
	Enabled	
<p>Enabled – Robot set Watch Dog Timer (WDT) after POST completion, before BIOS transfer control to OS. WARNING: Before enabling this function, a program in OS must be in responsible for clearing WDT. Also, this function should be disabled if OS I going to update itself.</p>		

Options Summary		
Delayed POST (PEI phase)	Disabled	Optimal Default, Failsafe Default
	Enabled	
<p>Enabled -Robot holds BIOS from starting POST, right after power on. This allows BIOS POST to start with stable power or start after system is physically warmed-up.</p> <p>Note: Robot does this before 'Sends watch dog'.</p>		
Delayed POST (DXE phase)	Disabled	Optimal Default, Failsafe Default
	Enabled	
<p>Enabled -Robot holds BIOS before POST completion. This allows BIOS POST to start with stable power or start after system is physically warmed-up.</p> <p>Note: Robot does this after 'Sends watch dog before BIOS POST'.</p>		

3.4.6.1 Device Detecting Configuration

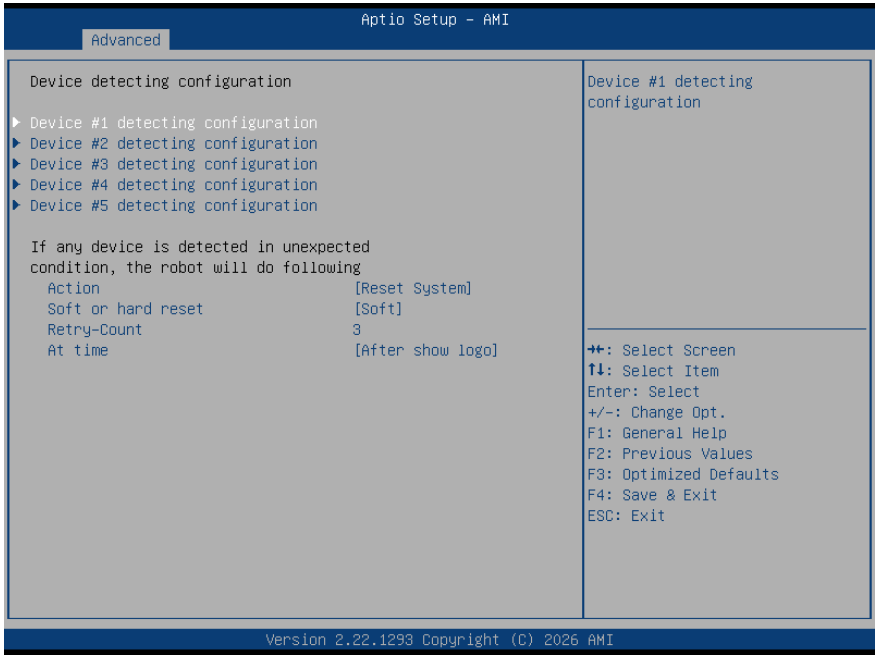

Options Summary		
Action	Reset System	Optimal Default, Failsafe Default
	Hold System	
Select action that robot should do.		
Soft or hard reset	Soft	Optimal Default, Failsafe Default
	Hard	
Select reset type robot should send on each boot.		
Retry-Count	3	Optimal Default, Failsafe Default
Fill retry counter here. Robot will reset system at most counter times, and then let system continue its POST.		
At time	After show logo	Optimal Default, Failsafe Default
	Before show logo	
Select robot action time: After show logo - Robot will do action after logo is displayed. System devices are almost ready.		
Before show logo - Robot will do action earlier before logo, but some devices may not be ready.		

3.4.6.1.1 Device #1 Detecting Configuration

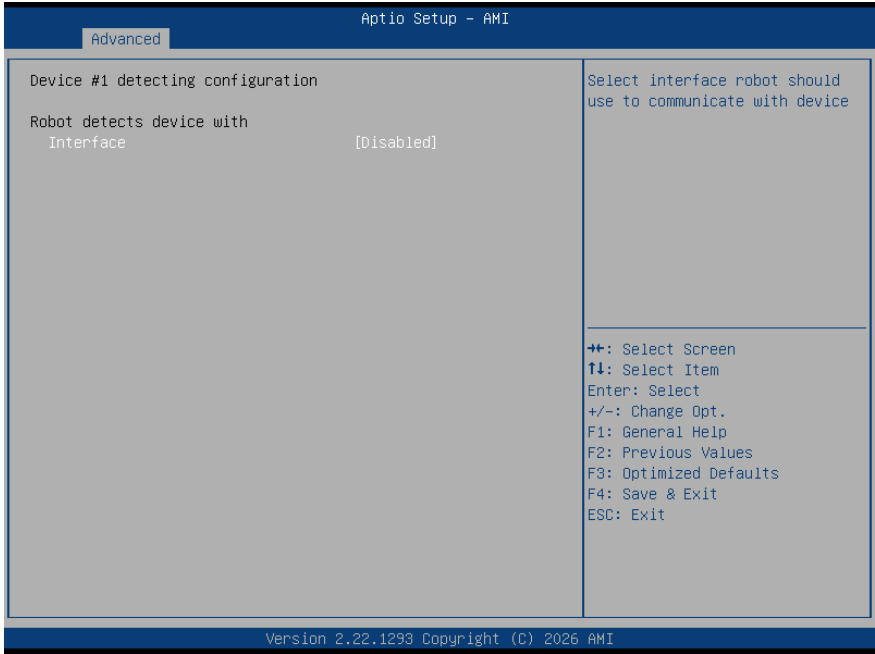

Options Summary		
Interface	Disabled	Optimal Default, Failsafe Default
	PCI	
	DIO	
	SMBUS	
	Legacy I/O	
	Super I/O	
	MMIO	
Select interface robot should use to communicate with device.		

3.4.6.1.2 Device #2 Detecting Configuration

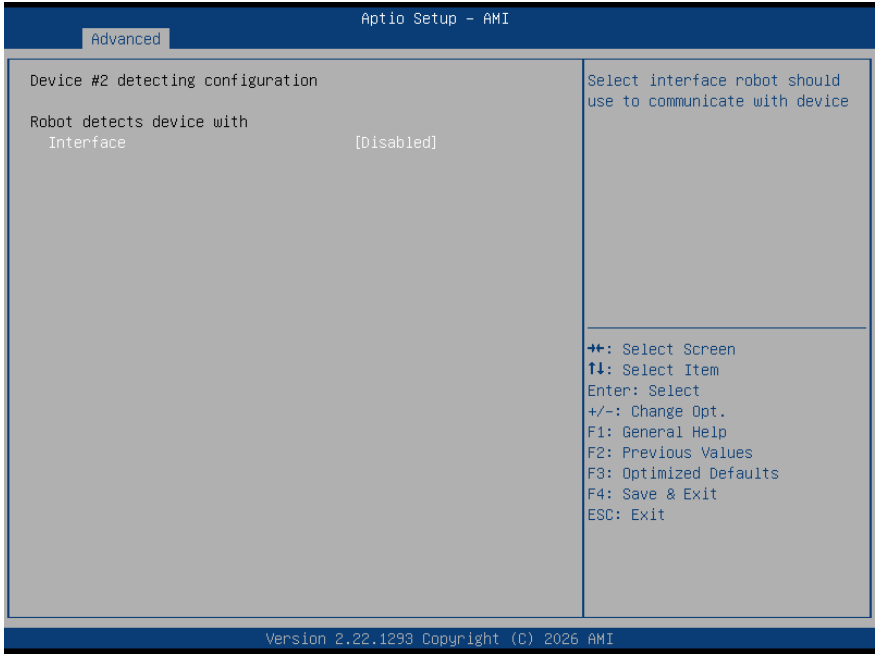

Options Summary		
Interface	Disabled	Optimal Default, Failsafe Default
	PCI	
	DIO	
	SMBUS	
	Legacy I/O	
	Super I/O	
	MMIO	
Select interface robot should use to communicate with device.		

3.4.6.1.3 Device #3 Detecting Configuration

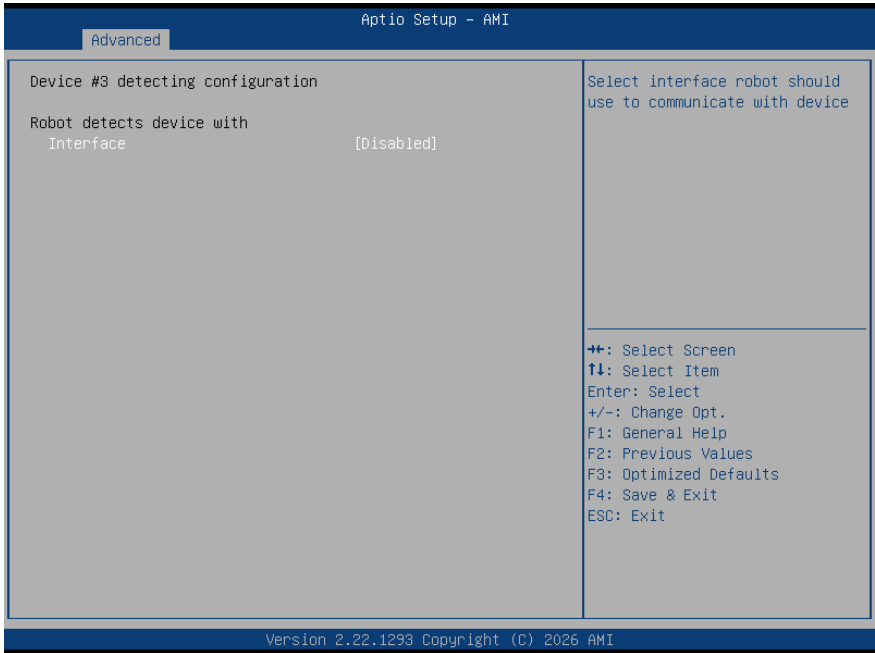

Options Summary		
Interface	Disabled	Optimal Default, Failsafe Default
	PCI	
	DIO	
	SMBUS	
	Legacy I/O	
	Super I/O	
	MMIO	
Select interface robot should use to communicate with device.		

3.4.6.1.4 Device #4 Detecting Configuration

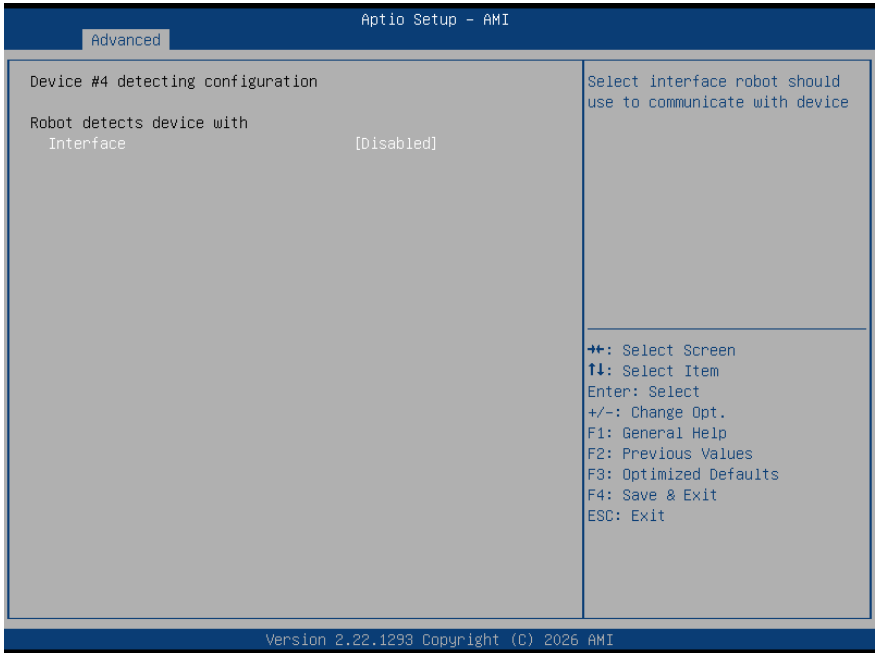

Options Summary		
Interface	Disabled	Optimal Default, Failsafe Default
	PCI	
	DIO	
	SMBUS	
	Legacy I/O	
	Super I/O	
	MMIO	
Select interface robot should use to communicate with device.		

3.4.6.1.5 Device #5 Detecting Configuration

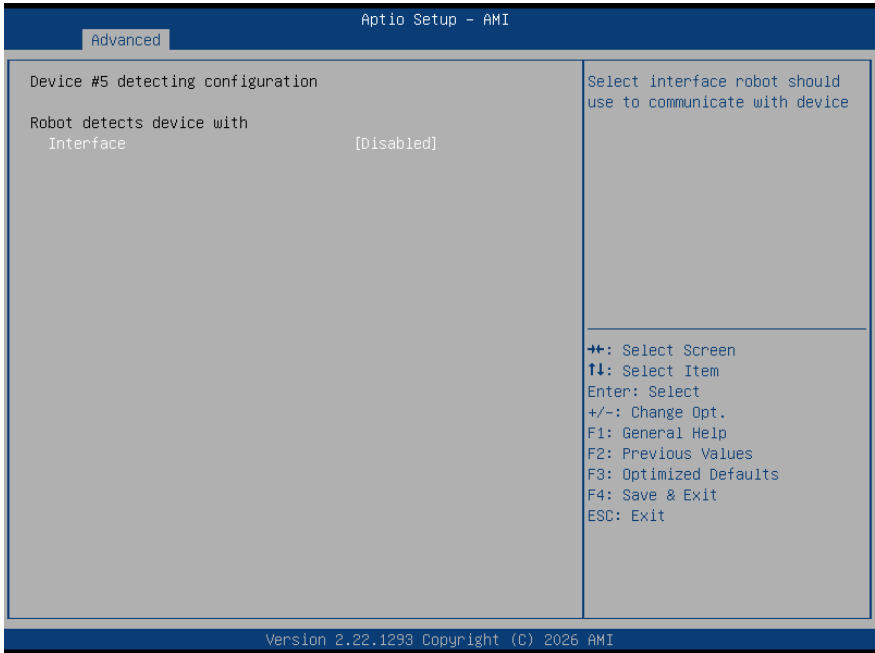

Options Summary		
Interface	Disabled	Optimal Default, Failsafe Default
	PCI	
	DIO	
	SMBUS	
	Legacy I/O	
	Super I/O	
	MMIO	
Select interface robot should use to communicate with device.		

3.5 Setup Submenu: Chipset

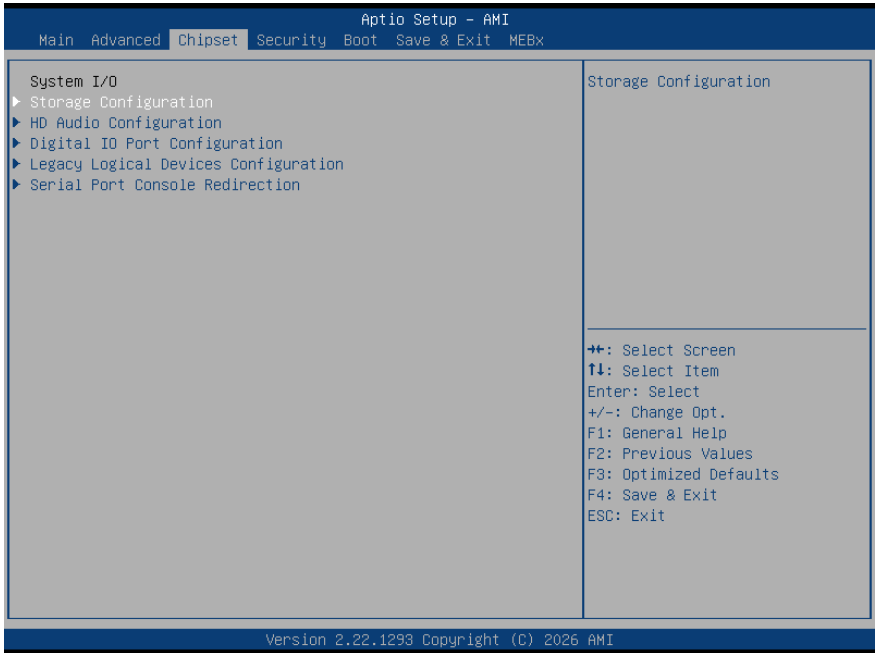

3.5.1 Storage Configuration

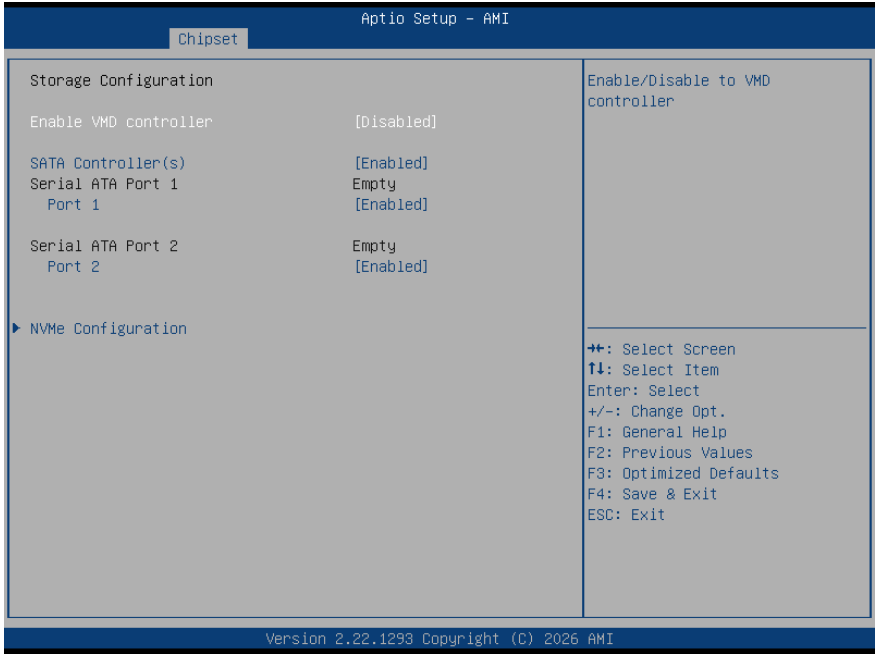

Options Summary		
Enable VMD controller	Disabled	Optimal Default, Failsafe Default
	Enabled	
Enable/Disable to VMD controller.		
SATA Controller(s)	Enabled	Optimal Default, Failsafe Default
	Disabled	
Enable/Disable to SATA Device.		
Port 1	Enabled	Optimal Default, Failsafe Default
	Disabled	
Enable or Disable SATA Port.		
Port 2	Enabled	Optimal Default, Failsafe Default
	Disabled	
Enable or Disable SATA Port.		

3.5.2 NVMe Configuration

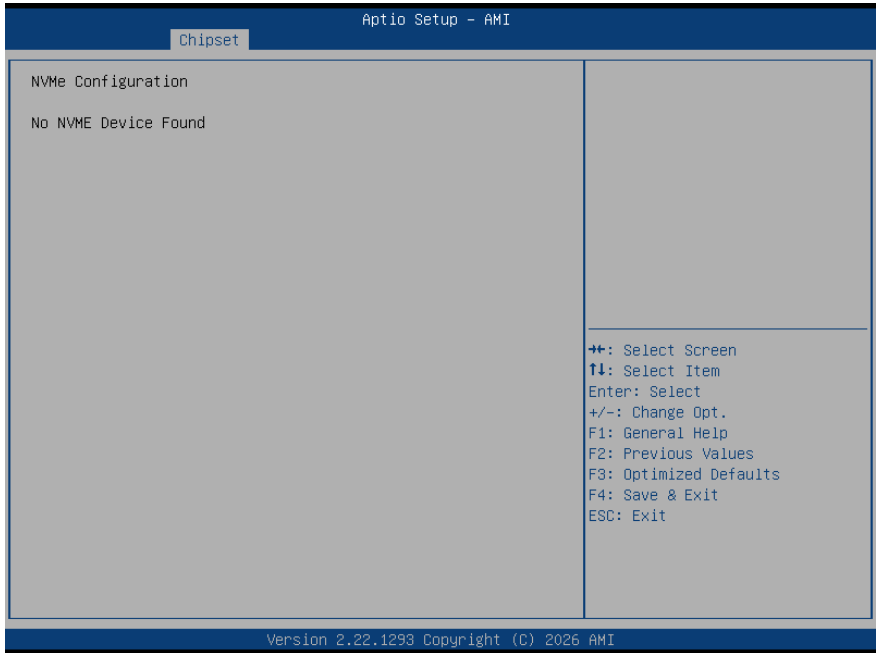

3.5.3 HD Audio Configuration

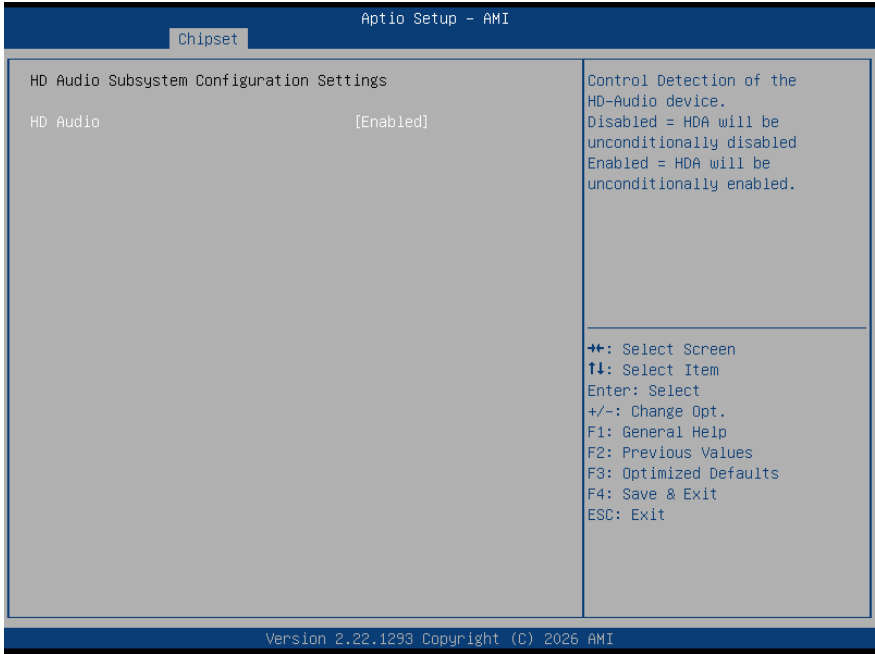

Options Summary		
HD Audio	Disabled	
	Enabled	Optimal Default, Failsafe Default
Control Detection of the HD-Audio device. Disabled = HDA will be unconditionally disabled. Enabled = HDA will be unconditionally enabled.		

3.5.4 Digital IO Port Configuration



Options Summary		
DIO1	Input	
	Output	Optimal Default, Failsafe Default
Set DIO as Input or Output.		
Output Level	Low	
	High	Optimal Default, Failsafe Default
Set output level when DIO pin is output.		
DIO2	Input	
	Output	Optimal Default, Failsafe Default
Set DIO as Input or Output.		
Output Level	Low	
	High	Optimal Default, Failsafe Default
Set output level when DIO pin is output.		
DIO3	Input	
	Output	Optimal Default, Failsafe Default
Set DIO as Input or Output.		

Options Summary		
Output Level	Low	
	High	Optimal Default, Failsafe Default
Set output level when DIO pin is output.		
DIO4	Input	
	Output	Optimal Default, Failsafe Default
Set DIO as Input or Output.		
Output Level	Low	
	High	Optimal Default, Failsafe Default
Set output level when DIO pin is output.		
DIO5	Input	Optimal Default, Failsafe Default
	Output	
Set DIO as Input or Output.		
DIO6	Input	Optimal Default, Failsafe Default
	Output	
Set DIO as Input or Output.		
DIO7	Input	Optimal Default, Failsafe Default
	Output	
Set DIO as Input or Output.		
DIO8	Input	Optimal Default, Failsafe Default
	Output	
Set DIO as Input or Output.		

3.5.5 Legacy Logical Devices Configuration

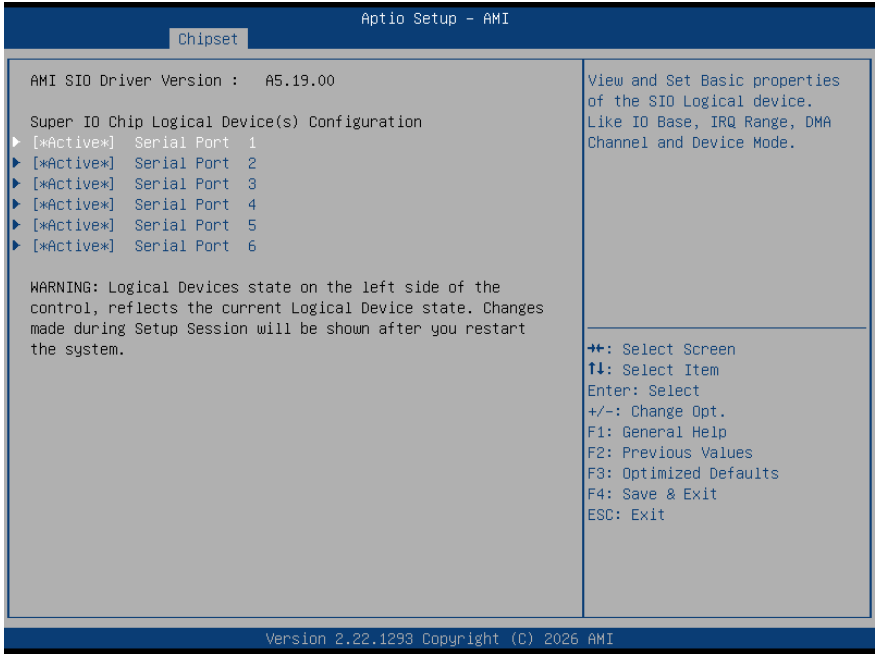

3.5.5.1 Serial Port 1

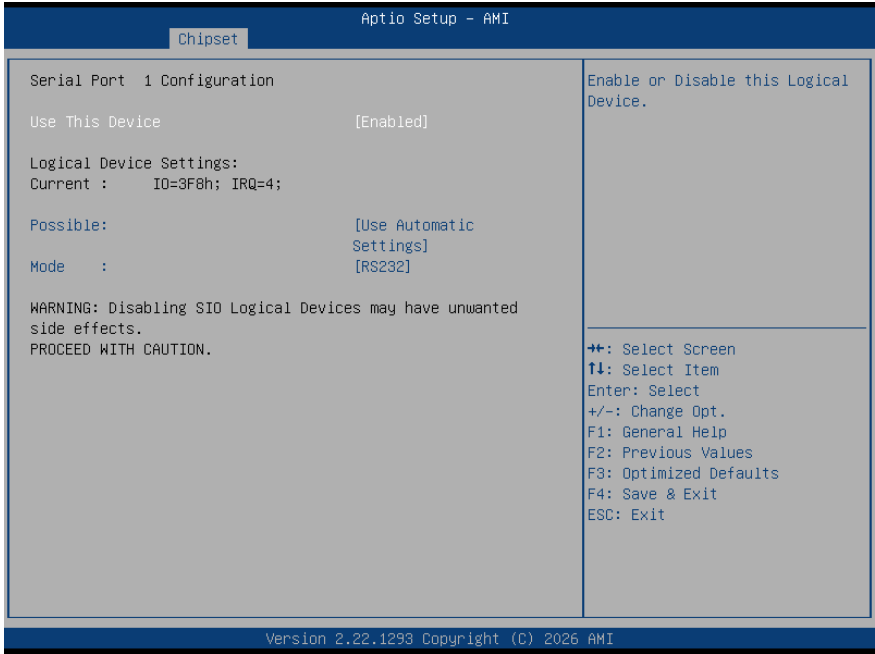

Options Summary		
Use This Device	Disabled	
	Enabled	Optimal Default, Failsafe Default
Enable or Disable this Logical Device.		
Possible:	Use Automatic Settings	Optimal Default, Failsafe Default
	IO=3F8; IRQ=4;	
	IO=2F8; IRQ=3;	
Allows the user to change the device resource settings. New settings will be reflected on this setup page after system restarts.		
Mode	RS232	Optimal Default, Failsafe Default
	RS422	
	RS485	
UART RS232, 422, 485, selection.		

3.5.5.2 Serial Port 2



Options Summary		
Use This Device	Disabled	
	Enabled	Optimal Default, Failsafe Default
Enable or Disable this Logical Device.		
Possible:	Use Automatic Settings	Optimal Default, Failsafe Default
	IO=2F8; IRQ=3;	
	IO=3F8; IRQ=4;	
Allows the user to change the device resource settings. New settings will be reflected on this setup page after system restarts.		
Mode	RS232	Optimal Default, Failsafe Default
	RS422	
	RS485	
UART RS232, 422, 485, selection.		

3.5.5.3 Serial Port 3



Options Summary		
Use This Device	Disabled	
	Enabled	Optimal Default, Failsafe Default
Enable or Disable this Logical Device.		
Possible:	Use Automatic Settings	Optimal Default, Failsafe Default
	IO=3E8; IRQ=11;	
	IO=2E8; IRQ=11;	
Allows the user to change the device resource settings. New settings will be reflected on this setup page after system restarts.		
Mode	RS232	Optimal Default, Failsafe Default
	RS422	
	RS485	
UART RS232, 422, 485, selection.		

3.5.5.4 Serial Port 4



Options Summary		
Use This Device	Disabled	
	Enabled	Optimal Default, Failsafe Default
Enable or Disable this Logical Device.		
Possible:	Use Automatic Settings	Optimal Default, Failsafe Default
	IO=2E8; IRQ=11;	
	IO=3E8; IRQ=11;	
Allows the user to change the device resource settings. New settings will be reflected on this setup page after system restarts.		
Mode	RS232	Optimal Default, Failsafe Default
	RS422	
	RS485	
UART RS232, 422, 485, selection.		

3.5.5.5 Serial Port 5



Options Summary		
Use This Device	Disabled	
	Enabled	Optimal Default, Failsafe Default
Enable or Disable this Logical Device.		
Possible:	Use Automatic Settings	Optimal Default, Failsafe Default
	IO=2D0; IRQ=11;	
	IO=2C0; IRQ=11;	
Allows the user to change the device resource settings. New settings will be reflected on this setup page after system restarts.		
Mode	RS232	Optimal Default, Failsafe Default
	RS422	
	RS485	
UART RS232, 422, 485, selection.		

3.5.5.6 Serial Port 6

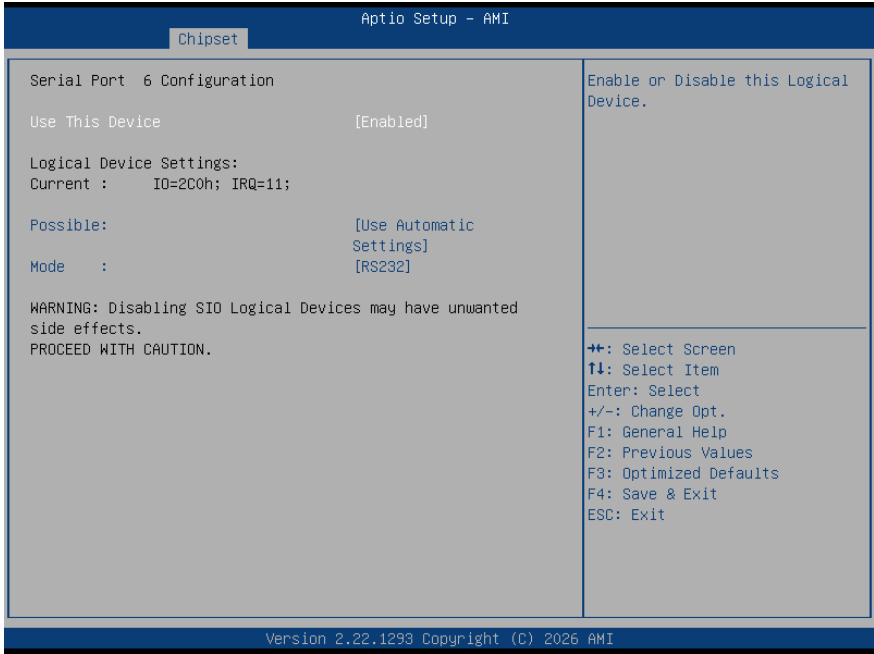

Options Summary		
Use This Device	Disabled	
	Enabled	Optimal Default, Failsafe Default
Enable or Disable this Logical Device.		
Possible:	Use Automatic Settings	Optimal Default, Failsafe Default
	IO=2C0; IRQ=11;	
	IO=2D0; IRQ=11;	
Allows the user to change the device resource settings. New settings will be reflected on this setup page after system restarts.		
Mode	RS232	Optimal Default, Failsafe Default
	RS422	
	RS485	
UART RS232, 422, 485, selection.		

3.5.6 Serial Port Console Redirection

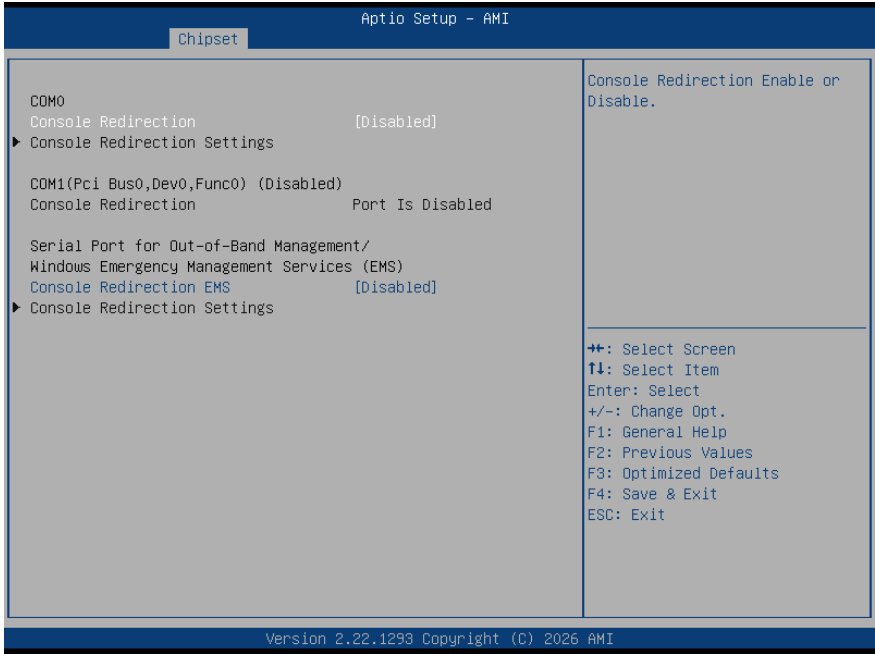

Options Summary		
Console Redirection	Disabled	Optimal Default, Failsafe Default
	Enabled	
Console Redirection Enable or Disable.		
Console Redirection EMS	Disabled	Optimal Default, Failsafe Default
	Enabled	
Console Redirection Enable or Disable.		

3.5.6.1 Console Redirection Settings (COM0)

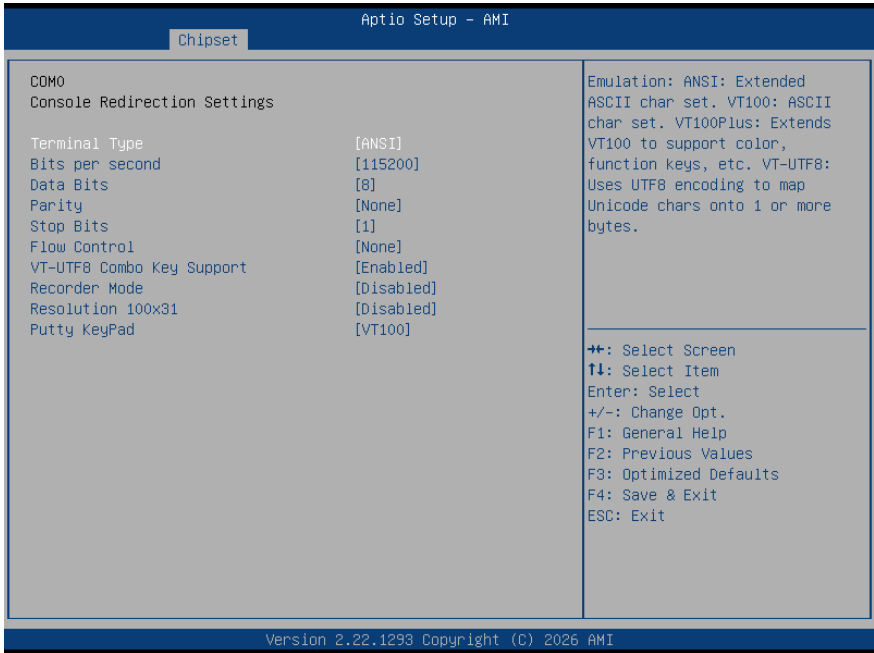

Options Summary		
Terminal Type	VT100	
	VT100Plus	
	VT-UTF8	
	ANSI	Optimal Default, Failsafe Default
Emulation: ANSI: Extended ASCII char set. VT100: ASCII char set. VT100Plus: Extends VT100 to support color, function keys, etc. VT-UTF8: Uses UTF8 encoding to map Unicode chars onto 1 or more bytes.		
Bits per second	9600	
	19200	
	38400	
	57600	
	115200	Optimal Default, Failsafe Default

Options Summary		
Selects serial port transmission speed. The speed must be matched on the other side. Long or noisy lines may require lower speeds.		
Data Bits	7	
	8	Optimal Default, Failsafe Default
Data Bits.		
Parity	None	Optimal Default, Failsafe Default
	Even	
	Odd	
	Mark	
	Space	
A parity bit can be sent with the data bits to detect some transmission errors. Even: parity bit is 0 if the num of 1's in the data bits is even. Odd: parity bit is 0 if num of 1's in the data bits is odd. Mark: parity bit is always 1. Space: Parity bit is always 0. Mark and Space Parity do not allow for error detection. They can be used as an additional data bit.		
Stop Bits	1	Optimal Default, Failsafe Default
	2	
Stop bits indicate the end of a serial data packet. (A start bit indicates the beginning). The standard setting is 1 stop bit. Communication with slow devices may require more than 1 stop bit.		
Flow Control	None	Optimal Default, Failsafe Default
	Hardware RTS/CTS	
Flow control can prevent data loss from buffer overflow. When sending data, if the receiving buffers are full, a 'stop' signal can be sent to stop the data flow. Once the buffers are empty, a 'start' signal can be sent to re-start the flow. Hardware flow control uses two wires to send start/stop signals.		
VT-UTF8 Combo Key Support	Disabled	
	Enabled	Optimal Default, Failsafe Default
Enable VT-UTF8 Combination Key Support for ANSI/VT100 terminals.		
Recorder Mode	Disabled	Optimal Default, Failsafe Default
	Enabled	
With this mode enabled only text will be sent. This is to capture Terminal data.		
Resolution 100x31	Disabled	Optimal Default, Failsafe Default
	Enabled	
Enables or disables extended terminal resolution.		

Options Summary		
Putty KeyPad	VT100	Optimal Default, Failsafe Default
	LINUX	
	XTERMR6	
	SCO	
	ESCN	
	VT400	
Select FunctionKey and KeyPad on Putty.		

3.5.6.2 Console Redirection Settings (Out-of-Band Mgmt)

Aptio Setup - AMI

Chipset

Out-of-Band Mgmt Port Terminal Type EMS Bits per second EMS Flow Control EMS Data Bits EMS Parity EMS Stop Bits EMS	[COM0] [VT-UTF8] [115200] [None] 8 None 1	Microsoft Windows Emergency Management Services (EMS) allows for remote management of a Windows Server OS through a serial port.
---	---	--

++: Select Screen
 ↑↓: Select Item
 Enter: Select
 +/-: Change Opt.
 F1: General Help
 F2: Previous Values
 F3: Optimized Defaults
 F4: Save & Exit
 ESC: Exit

Version 2.22.1293 Copyright (C) 2026 AMI

Options Summary		
Out-of-Band Mgmt Port	COM0	Optimal Default, Failsafe Default
	COM1(Pci Bus0, Dev0, Func0) (Disabled)	
Microsoft Windows Emergency Management Services (EMS) allows for remote management of a Windows Server OS through a serial port.		

Options Summary		
Terminal Type EMS	VT100	
	VT100Plus	
	VT-UTF8	Optimal Default, Failsafe Default
	ANSI	
<p>VT-UTF8 is the preferred terminal type for out-of-band management. The next best choice is VT100+ and then VT100. See above, in Console Redirection Settings page, for more Help with Terminal Type/Emulation.</p>		
Bits per second EMS	9600	
	19200	
	57600	
	115200	Optimal Default, Failsafe Default
<p>Selects serial port transmission speed. The speed must be matched on the other side. Long or noisy lines may require lower speeds.</p>		
Flow Control EMS	None	Optimal Default, Failsafe Default
	Hardware RTS/CTS	
	Software Xon/Xoff	
<p>Flow control can prevent data loss from buffer overflow. When sending data, if the receiving buffers are full, a 'stop' signal can be sent to stop the data flow. Once the buffers are empty, a 'start' signal can be sent to re-start the flow. Hardware flow control uses two wires to send start/stop signals.</p>		

3.6 Setup Submenu: Security

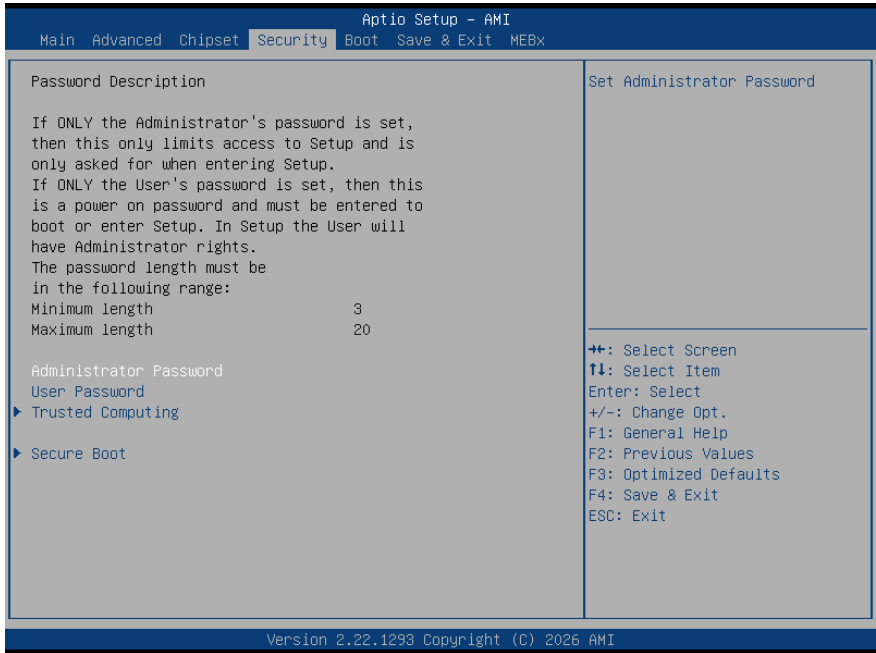

Change User/Administrator Password

You can set a User Password once an Administrator Password. The password will be required during boot up, or when the user enters the Setup utility. Please Note that a User Password does not provide access to many of the features in the Setup utility.

Select the password you wish to set, press Enter to open a dialog box to enter your password (you can enter no more than six letters or numbers). Press Enter to confirm your entry, after which you will be prompted to retype your password for a final confirmation. Press Enter again after you have retyped it correctly.

Removing the Password

Highlight this item and type in the current password. At the next dialog box press Enter to disable password protection.

3.6.1 Trusted Computing

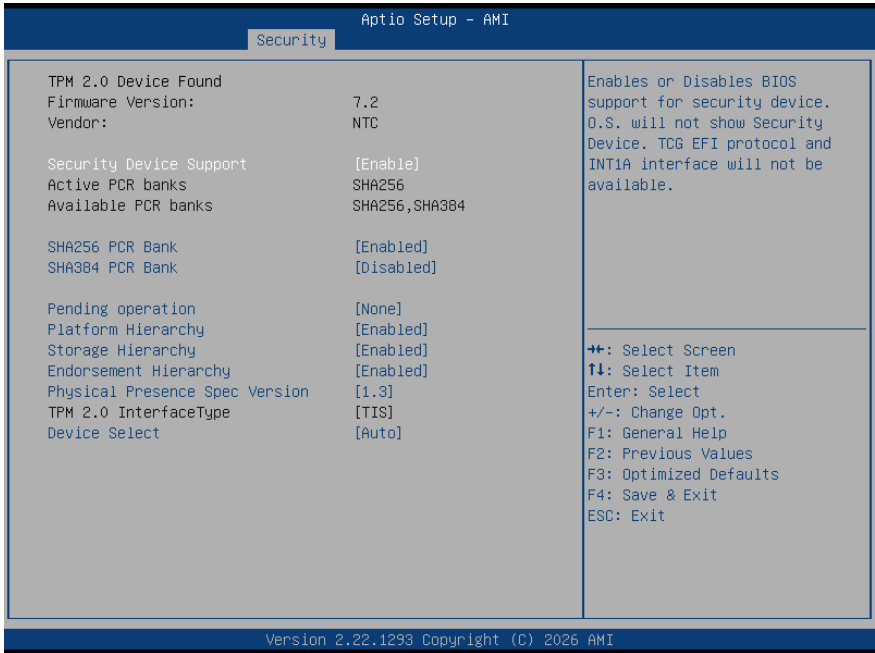

Options Summary		
Security Device Support	Enable	Optimal Default, Failsafe Default
	Disable	
Enables or Disables BIOS support for security device. O.S. will not show Security Device. TCG EFI protocol and INT1A interface will not be available.		
SHA256 PCR Bank	Disabled	
	Enabled	Optimal Default, Failsafe Default
Enable or Disable SHA256 PCR Bank.		
SHA384 PCR Bank	Disabled	Optimal Default, Failsafe Default
	Enabled	
Enable or Disable SHA384 PCR Bank.		
Pending operation	None	Optimal Default, Failsafe Default
	TPM Clear	
Schedule an Operation for the Security Device. NOTE: Your Computer will reboot during restart in order to change State of Security Device.		

Options Summary		
Platform Hierarchy	Disabled	
	Enabled	Optimal Default, Failsafe Default
Enable or Disable Platform Hierarchy.		
Storage Hierarchy	Disabled	
	Enabled	Optimal Default, Failsafe Default
Enable or Disable Storage Hierarchy.		
Endorsement Hierarchy	Disabled	
	Enabled	Optimal Default, Failsafe Default
Enable or Disable Endorsement Hierarchy.		
Physical Presence Spec Version	1.2	
	1.3	Optimal Default, Failsafe Default
Select to Tell O.S. to support PPI Spec Version 1.2 or 1.3. Note some HCK tests might not support 1.3.		
Device Select	TPM 1.2	
	TPM 2.0	
	Auto	Optimal Default, Failsafe Default
TPM 1.2 will restrict support to TPM 1.2 devices. TPM 2.0 will restrict support to TPM 2.0 devices. Auto will support both with the default set to TPM 2.0 devices if not found. TPM 1.2 devices will be enumerated.		

3.6.2 Secure Boot

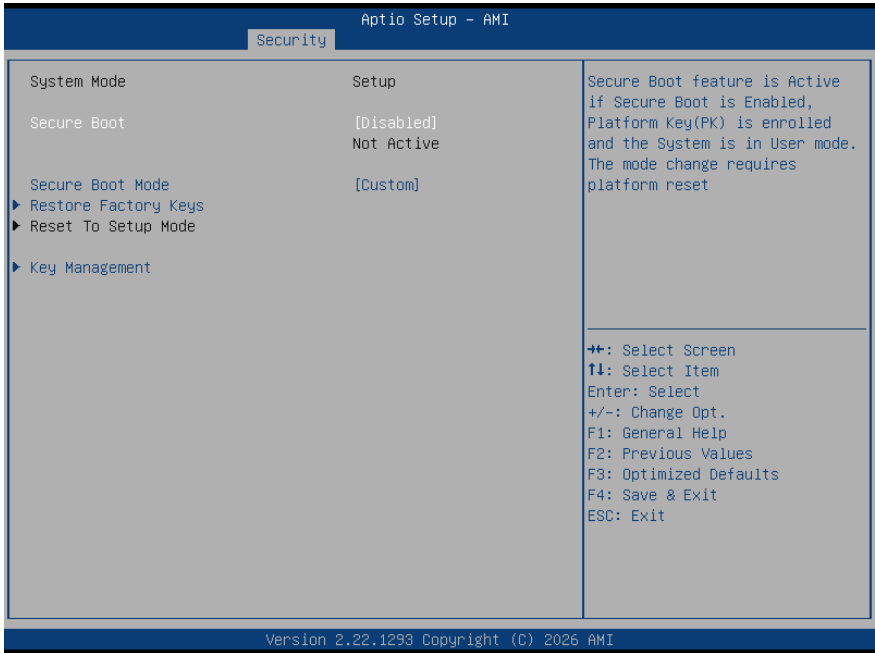

Options Summary		
Secure Boot	Disabled	Optimal Default, Failsafe Default
	Enabled	
Secure Boot feature is Active if Secure Boot is Enabled, Platform Key (PK) is enrolled and the System is in User mode. The mode change requires platform reset.		
Secure Boot Mode	Standard	
	Custom	Optimal Default, Failsafe Default
Secure Boot mode options: Standard or Custom. In Custom mode, Secure Boot Policy variables can be configured by a physically present user without full authentication.		
Restore Factory Keys	Yes	
	No	
Force System to User Mode. Install factory default Secure Boot key databases.		

3.6.2.1 Key Management



Options Summary		
Factory Key Provision	Disabled	Optimal Default, Failsafe Default
	Enabled	
Install factory default Secure Boot keys after the platform reset and while the System is in Setup mode.		
Restore Factory Keys	Yes	
	No	
Force System to User Mode. Install factory default Secure Boot key databases.		
Enroll Efi Image		
Allow Efi image to run in Secure Boot mode. Enroll SHA256 Hash certificate of a PE image into Authorized Signature Database (db).		
Platform Key (PK)	Update	
Key Exchange Keys (KEK)	Update	
	Append	
Authorized Signatures (db)	Update	
	Append	

Options Summary

Forbidden Signatures (dbx)	Update	
	Append	
Authorized TimeStamps (dbt)	Update	
	Append	
OsRecovery Signatures (dbr)	Update	
	Append	

Enroll Factory Defaults or load certificates from a file:

1. Public Key Certificate:
 - a) EFI_SIGNATURE_LIST
 - b) EFI_CERT_X509 (DER)
 - c) EFI_CERT_RSA2048 (bin)
 - d) EFI_CERT_SHAXXX
2. Authenticated UEFI Variable
3. EFI PE/COFF Image (SHA256)

Key Source: Factory, External, Mixed.

3.7 Setup Submenu: Boot



Options Summary		
Quiet Boot	Disabled	
	Enabled	Default
Enables/disables Quiet Boot option.		
Network Stack	Disabled	Default
	Enabled	
Enable/Disable UEFI Network Stack.		
Boot Option #1	Hard Disk	
Boot Option #2	NVME	
Boot Option #3	USB Device	
Boot Option #4	Network	
Sets the system boot order.		

3.7.1 UEFI BBS Priorities



3.8 Setup Submenu: Save & Exit

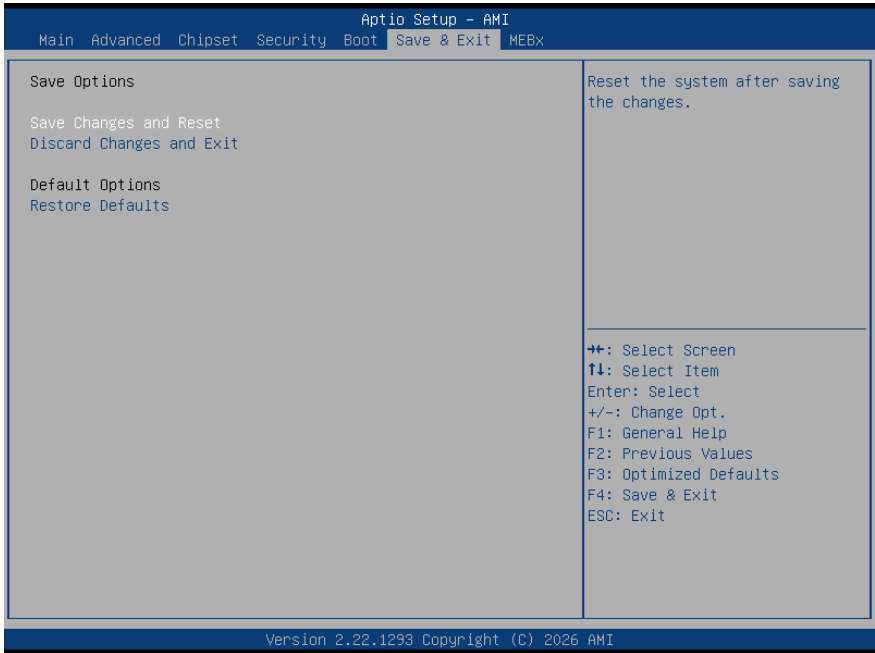

3.9 Setup Submenu: MEBx



Chapter 4

Drivers Installation

4.1 Drivers Download and Installation

Drivers for the BOXER-6839-RPL can be downloaded from the product page on the AAEON website by following this link:

<https://www.aaeon.com/en/product/list/expansion-box-pc>





Appendix A

I/O Information





































A.1 I/O Address Map

Input/output (IO)	
[0000000000000000 - 000000000000CF7]	PCI Express Root Complex
[0000000000000020 - 000000000000021]	Programmable interrupt controller
[0000000000000024 - 000000000000025]	Programmable interrupt controller
[0000000000000028 - 000000000000029]	Programmable interrupt controller
[000000000000002C - 00000000000002D]	Programmable interrupt controller
[000000000000002E - 00000000000002F]	Motherboard resources
[0000000000000030 - 000000000000031]	Programmable interrupt controller
[0000000000000034 - 000000000000035]	Programmable interrupt controller
[0000000000000038 - 000000000000039]	Programmable interrupt controller
[000000000000003C - 00000000000003D]	Programmable interrupt controller
[0000000000000040 - 000000000000043]	System timer
[000000000000004E - 00000000000004F]	Motherboard resources
[0000000000000050 - 000000000000053]	System timer
[0000000000000061 - 000000000000061]	Motherboard resources
[0000000000000063 - 000000000000063]	Motherboard resources
[0000000000000065 - 000000000000065]	Motherboard resources
[0000000000000067 - 000000000000067]	Motherboard resources
[0000000000000070 - 000000000000070]	Motherboard resources
[0000000000000080 - 000000000000080]	Motherboard resources
[0000000000000092 - 000000000000092]	Motherboard resources
[00000000000000A0 - 00000000000000A1]	Programmable interrupt controller
[00000000000000A4 - 00000000000000A5]	Programmable interrupt controller
[00000000000000A8 - 00000000000000A9]	Programmable interrupt controller
[00000000000000AC - 00000000000000AD]	Programmable interrupt controller
[00000000000000B0 - 00000000000000B1]	Programmable interrupt controller
[00000000000000B2 - 00000000000000B3]	Motherboard resources
[00000000000000B4 - 00000000000000B5]	Programmable interrupt controller
[00000000000000B8 - 00000000000000B9]	Programmable interrupt controller
[00000000000000BC - 00000000000000BD]	Programmable interrupt controller
[00000000000002C0 - 00000000000002C7]	Fintek Communications Port (COM6)
[00000000000002D0 - 00000000000002D7]	Fintek Communications Port (COM5)
[00000000000002E8 - 00000000000002EF]	Fintek Communications Port (COM4)
[00000000000002F8 - 00000000000002FF]	Fintek Communications Port (COM2)
[00000000000003E8 - 00000000000003EF]	Fintek Communications Port (COM3)
[00000000000003F8 - 00000000000003FF]	Fintek Communications Port (COM1)
[00000000000004D0 - 00000000000004D1]	Programmable interrupt controller
[0000000000000680 - 000000000000069F]	Motherboard resources
[0000000000000A00 - 0000000000000A0F]	Motherboard resources
[0000000000000A10 - 0000000000000A1F]	Motherboard resources
[0000000000000A20 - 0000000000000A2F]	Motherboard resources
[0000000000000D00 - 0000000000000FFF]	PCI Express Root Complex
[000000000000164E - 000000000000164F]	Motherboard resources
[0000000000001854 - 0000000000001857]	Motherboard resources
[0000000000002000 - 00000000000020FE]	Motherboard resources
[0000000000003000 - 0000000000003FFF]	Intel(R) PCI Express Root Port #6 - 7ABD
[0000000000004000 - 0000000000004FFF]	Intel(R) PCI Express Root Port #5 - 7ABC
[0000000000005000 - 000000000000503F]	Intel(R) UHD Graphics 770
[0000000000005060 - 000000000000507F]	Standard SATA AHCI Controller
[0000000000005080 - 0000000000005083]	Standard SATA AHCI Controller
[0000000000005090 - 0000000000005097]	Standard SATA AHCI Controller
[000000000000EFA0 - 000000000000EFBF]	Intel(R) SMBus - 7AA3

A.2 IRQ Mapping Chart

- ▼  Interrupt request (IRQ)
 -  (ISA) 0x00000000 (00) System timer
 -  (ISA) 0x00000003 (03) Fintek Communications Port (COM2)
 -  (ISA) 0x00000004 (04) Fintek Communications Port (COM1)
 -  (ISA) 0x0000000B (11) Fintek Communications Port (COM3)
 -  (ISA) 0x0000000B (11) Fintek Communications Port (COM4)
 -  (ISA) 0x0000000B (11) Fintek Communications Port (COM5)
 -  (ISA) 0x0000000B (11) Fintek Communications Port (COM6)
 -  (ISA) 0x00000037 (55) Microsoft ACPI-Compliant System
 -  (ISA) 0x00000038 (56) Microsoft ACPI-Compliant System
 -  (ISA) 0x00000039 (57) Microsoft ACPI-Compliant System

A.3 Memory Address Map

- ▼  Large Memory
 -  [0000004000000000 - 0000007FFFFFFF] PCI Express Root Complex
- ▼  Memory
 -  [00000000000A0000 - 0000000000BFFFFF] PCI Express Root Complex
 -  [0000000804000000 - 0000000804FFFFFF] Intel(R) Ethernet Controller I226-LM
 -  [0000000805000000 - 0000000805FFFFFF] Intel(R) PCI Express Root Port #4 - 7ABB
 -  [0000000804000000 - 0000000BFFFFFF] PCI Express Root Complex
 -  [0000000805000000 - 000000080503FFFF] Intel(R) Ethernet Controller I226-LM
 -  [0000000806000000 - 0000000806FFFFFF] Intel(R) PCI Express Root Port #6 - 7ABD
 -  [0000000806DC0000 - 0000000806DFFFFF] Intel(R) I210 Gigabit Network Connection #2
 -  [0000000806E00000 - 0000000806FFFFFF] Intel(R) I210 Gigabit Network Connection #2
 -  [0000000807000000 - 0000000807FFFFFF] Intel(R) PCI Express Root Port #5 - 7ABC
 -  [0000000807DC0000 - 0000000807DFFFFF] Intel(R) I210 Gigabit Network Connection
 -  [0000000807E00000 - 0000000807FFFFFF] Intel(R) I210 Gigabit Network Connection
 -  [0000000808200000 - 000000080821FFFF] Standard SATA AHCI Controller
 -  [0000000808220000 - 0000000808227FFF] Standard SATA AHCI Controller
 -  [0000000808230000 - 0000000808230FFF] Standard SATA AHCI Controller
 -  [0000000BFFDF0000 - 0000000BFFDFFFFF] Intel(R) Active Management Technology - SOL (COM7)
 -  [0000000BFFE00000 - 0000000BFFFFFF] Intel(R) Ethernet Connection (17) I219-LM
 -  [00000000C0000000 - 00000000CFFFFFFF] Motherboard resources
 -  [00000000FE010000 - 00000000FE010FFF] Intel(R) SPI (flash) Controller - 7AA4
 -  [00000000FED00000 - 00000000FED003FF] High precision event timer
 -  [00000000FED20000 - 00000000FED7FFFF] Motherboard resources
 -  [00000000FED40000 - 00000000FED44FFF] Trusted Platform Module 2.0
 -  [00000000FED45000 - 00000000FED8FFFF] Motherboard resources
 -  [00000000FED90000 - 00000000FED93FFF] Motherboard resources
 -  [00000000FEDA0000 - 00000000FEDA0FFF] Motherboard resources
 -  [00000000FEDA1000 - 00000000FEDA1FFF] Motherboard resources
 -  [00000000FEDC0000 - 00000000FEDC7FFF] Motherboard resources
 -  [00000000FEE00000 - 00000000FEEFFFFFFF] Motherboard resources
 -  [0000004000000000 - 000000400FFFFFFF] Intel(R) UHD Graphics 770
 -  [0000006000000000 - 0000006000FFFFFF] Intel(R) UHD Graphics 770
 -  [0000006001100000 - 000000600110FFFF] Intel(R) USB 3.20 eXtensible Host Controller - 1.20 (Microsoft)
 -  [0000006001118000 - 00000060011180FF] Intel(R) SMBus - 7AA3
 -  [0000007FFFEFB000 - 0000007FFFEFBFFF] Intel(R) Management Engine Interface #1
 -  [0000007FFFEFC000 - 0000007FFFEFCFFF] Intel® Smart Sound Technology BUS
 -  [0000007FFFEFD000 - 0000007FFFEFDFFF] Intel® Smart Sound Technology BUS