

Industrial Motherboard

ATX-Q870A

HDMI[™]
HIGH-DEFINITION MULTIMEDIA INTERFACE

March 2026

Copyright Notice

This document is copyrighted, 2026. All rights are reserved. The original manufacturer reserves the right to make improvements to the products described in this manual at any time without notice.

No part of this manual may be reproduced, copied, translated, or transmitted in any form or by any means without the prior written permission of the original manufacturer. Information provided in this manual is intended to be accurate and reliable. However, the original manufacturer assumes no responsibility for its use, or for any infringements upon the rights of third parties that may result from its use. The material in this document is for product information only and is subject to change without notice. While reasonable efforts have been made in the preparation of this document to assure its accuracy, the original manufacturer assumes no liabilities resulting from errors or omissions in this document, or from the use of the information contained herein.

The original manufacturer reserves the right to make changes in the product design without notice to its users.

Acknowledgments

All other products' name or trademarks are properties of their respective owners. AMI is a trademark of American Megatrends Inc.

- Intel® is a registered trademark of Intel® Corporation
- Core™ Ultra is a trademark of Intel® Corporation.
- Microsoft Windows® is a registered trademark of Microsoft Corp.
- IBM, PC/AT, PS/2, and VGA are trademarks of International Business Machines Corporation.
- Linux® is a registered trademark of Linus Torvalds in the United States and other countries.

The original manufacturer reserves the right to make changes in the product design without notice to its users.

All other product names or trademarks are properties of their respective owners.

Contents

CHAPTER 1		1
1.1	Package contents	1
1.2	Features	1
1.3	Specifications	2
CHAPTER 2		5
2.1	Before you Proceed	5
2.2	Motherboard Layout	6
2.3	Central Processing Unit (CPU)	8
2.3.1	Installing the CPU	9
2.3.2	CPU Heatsink and Fan Assembly Installation	11
2.3.3	System Memory	12
2.3.4	DIMM Installation	13
2.4	Jumpers	14
2.4.1	GPIO/80 Port Function Select (JP4)	15
2.4.2	ATX Mode/AT Mode Select (JAT_ATX)	16
2.4.3	Clear CMOS Function Select (JBAT1)	17
2.4.4	Case Open Function Select (JOPEN1)	18
2.4.5	COM 1 Header Pin-9 Function Select (JPCOM1)	19
2.4.6	COM 2 Header Pin-9 Function Select (JPCOM2)	20
2.4.7	COM 3 Header Pin-9 Function Select (JPCOM3)	21
2.4.8	COM 4 Header Pin-9 Function Select (JPCOM4)	22
2.4.9	COM 5 Header Pin-9 Function Select (JPCOM5)	23
2.4.10	COM 6 Header Pin-9 Function Select (JPCOM6)	24
2.5	List of Connectors	25
2.5.1	2.5GbE LAN/USB 3.2 Gen 2 Port Connector (UL1)	27
2.5.2	2.5GbE LAN/USB 3.2 Gen 2 Port Connector (UL2)	28
2.5.3	2.5GbE LAN/USB 3.2 Gen 2 Port Connector (UL3)	29
2.5.4	HDMI 2.1 TMDS Connectors (HDMI1/HDMI2)	30
2.5.5	Display Port (DP1)	30
2.5.6	VGA Connector (VGA)	31
2.5.7	CPU Fan Connector (CPUFAN1)	32
2.5.8	System Fan Connector (SYSFAN1)	33
2.5.9	System Fan Connector (SYSFAN2)	34
2.5.10	M2M1 Fan Connector (M2FAN1)	35
2.5.11	3W Amplifier Wafer (SPEAK_CON1)	36
2.5.12	I2C Header (I2C1)	37
2.5.13	SMBus Header (SMBUS1)	38
2.5.14	USB 3.2 Gen 1 Port Header (FP_USB1)	39
2.5.15	USB 2.0 Port Header (FP_USB2)	40

2.5.16	USB 2.0 Port Headers (FP_USB3/FP_USB4)	41
2.5.17	USB 2.0 Vertical Type-A Connectors (USB2/USB3)	42
2.5.18	PS/2 Keyboard and Mouse Header (PS2KBMS1)	43
2.5.19	Front Panel Audio Header (FP_AUDIO1)	44
2.5.20	Front Panel Header (FP)	45
2.5.21	SATA Connector (SATA1_2/SATA3_4)	46
2.5.22	Serial Port Connector (COM1)	47
2.5.23	RS-232 Serial Port Header (COM2 – COM6)	48
2.5.24	GPIO Port Header (GPIO1)	49
2.5.25	Nano SIM Card Socket (SIMCARD1)	50
2.5.26	M.2 2242/2280/22110 M-Key Slot (M2M1)	51
2.5.27	M.2 2280 M-Key Slot (M2M2)	52
2.5.28	M.2 3042/3052 B-Key Slot (M2B1)	53
2.5.29	M.2 2230 E-Key Slot (M2E1)	54
2.5.30	DDR5 U-DIMM Sockets (DDR5_A1/A2/B1/B2)	55
2.5.31	PCIe Gen 5 [x16] Slots (PCIE1/PCIE5)	56
2.5.32	PCIe Gen 4 [x1] Slots (PCIE2/PCIE3/PCIE6)	57
2.5.33	PCIe Gen 4 [x4] Slot (PCIE4/PCIE7)	58
2.5.34	Audio Line-In/Line-Out/Mic (AUDIO1)	59
2.5.35	24-Pin ATX Power Supply Connector (ATXPWR1)	60
2.5.36	8-Pin ATX 12V Power Connector (ATX12V1)	61

CHAPTER 3

		62
3.1	BIOS Setup Program	62
3.2	BIOS Menu Screen	64
3.3	Setup Submenu: Main Menu	65
3.4	Setup Submenu: Advanced	66
3.4.1	CNVi Mode Detection	67
3.4.2	CPU Configuration	68
3.4.3	Power & Performance	71
3.4.4	PCH-FW Configuration	76
3.4.5	Trusted Computing	77
3.4.6	ACPI Settings	78
3.4.7	Wake-up Function Settings	79
3.4.8	Super IO Configuration	81
3.4.9	PC Health Status	88
3.4.10	Smart Fan Configuration	89
3.4.11	Serial Port Console Redirection	90
3.4.12	Console Redirection Settings	93
3.4.13	USB Configuration	95
3.4.14	Network Stack	97
3.4.15	NVMe Configuration	99
3.5	Setup Submenu: Chipset	103

3.5.1	System Agent (SA) Configuration 1	104
3.5.2	System Agent (SA) Configuration 2	105
3.5.3	Graphics Configuration	106
3.5.4	VMD Setup Menu	107
3.5.5	PCH-IO Configuration	109
3.6	Setup Submenu: Security	112
3.6.1	Secure Boot	114
3.6.2	Key Management	115
3.6.3	Restore Factory Keys	116
3.6.4	Reset To Setup Mode	117
3.6.5	Platform Key (PK)	120
3.6.6	Key Exchange Keys	121
3.6.7	Authorized Signatures	122
3.6.8	Forbidden Signatures	123
3.6.9	Authorized TimeStamps	124
3.6.10	OsRecovery Signatures	125
3.7	Setup Submenu: Boot	126
3.7.1	BBS Priorities	127
3.8	Setup Submenu: Save & Exit	128
3.9	Setup Submenu: MEBx	129
APPENDIX		130
	FCC Statement	130
	China RoHS Requirements (CN)	131
	China RoHS Requirements (EN)	132

Chapter 1

Product Overview

1.1 Package contents

Check your industrial motherboard package for the following items:

- ☑ 1 x Industrial Motherboard
- ☑ 2 x COM Port Cable, 22cm, Pitch 2.0
- ☑ 2 x SATA Cable, 50cm
- ☑ 1 x SATA Power Y cable, 5.0pitch for 32cm, 2.54pitch for 20cm
- ☑ 1 x I/O Shield
- ☑ 2 x Jumper



If any of the above items is damaged or missing, contact your distributor or sales representative immediately

1.2 Features

- ☑ Intel® Core™ Ultra Processors (Series 2), LGA 1851 Socket, up to 125W
- ☑ DDR5 6400MT/s, Dual-Channel CU/U-DIMM x 4, up to 256GB
- ☑ PCIe Gen 5 [x16] x 2, PCIe Gen 4 [x4] x 2, PCIe Gen 4 [x1] x 3
- ☑ SATA 6Gb/s x 4 with RAID 0, 1, 5, 10
- ☑ Intel® Ethernet Controller I226, 2.5GbE x 3
- ☑ Intel® Q870 Chipset

1.3 Specifications

System	
Processor	Intel® Core™ Ultra Processors (Series 2), LGA 1851 Socket, up to 125W
Chipset	Intel® Q870 Chipset
Memory	DDR5 6400MT/s x 4, Dual-Channel CU/U-DIMM, up to 256GB
Graphics	Intel® Graphics
I/O Chipset	Fintek F81966D-I
Ethernet	Intel® Ethernet Controller I226-LM, 2.5GbE x 1 Intel® Ethernet Controller I226-V, 2.5GbE x 2
Audio	Realtek® ALC897 Audio Codec
TPM	Intel® PTT (fTPM)
Expansion Slot	PCIe Gen 5 [x16] x 2 (PCIe Gen 5 [x16] x 1 or PCIe Gen 5 [x8] x 2) PCIe Gen 4 [x4] x 2 PCIe Gen 4 [x1] x 3 M.2 2230 E-Key x 1 (USB 2.0/PCIe Gen 3 [x1]), CNVi supported M.2 3042/3052 B-Key x 1 (PCIe Gen 3 [x1]/USB 3.1/USB 2.0), 4G/5G supported
BIOS	UEFI
H/W Monitor	—
Watchdog Timer	255 Levels
Smart Fan Control	CPU Fan/System Fan
Wake on LAN/PXE	Yes (WoL)
Power State	S3, S5
Graphics	
Graphics Chipset	Intel® Graphics
Graphics Multi Display	Quad Display
VGA	VGA x 1 (Max Resolution: 1920 x 1080 @60Hz)
DVI	—
HDMI	HDMI 2.1 TMDS x 2 (Max Resolution: 3840 x 2160 @60Hz)
Display Port	DP 1.4a x 1 (Max Resolution: 4096 x 2160 @60Hz)
LVDS	—
eDP	—
Backlight Control	—
Environmental	
Battery	Lithium Battery
Power Requirement	ATX Power Supply, Internal 24+8-pin ATX Header

Operating Temperature	-4°F ~ 140°F (-20°C ~ 60°C) (Operational humidity: 10~90% Relative Humidity, Non-condensing)
Storage Temperature	-4°F ~ 185°F (-20°C ~ 85°C)
Certification	CE & FCC Class A, LVD
Form Factor	12" x 9.6" (305mm x 244mm)
Weight	TBD
MTBF (Hours)	—
Rear I/O Ports	
USB	USB 3.2 Gen 2 x 6
Display I/O	DP 1.4a x 1, HDMI 2.1 TMDS x 2, VGA x 1
Audio I/O	Mic-in x 1, Line-out x 1, Line-in x 1
LAN I/O	RJ-45 LAN x 3
Serial Port	DB-9 for RS-232/422/485 x 1
PS/2 Port	—
Others	—
Internal I/O Connectors	
Storage	M.2 2242/2260/2280/22110 M-Key x 1 (PCIe Gen 5 [x4]), NVMe supported M.2 2280 M-Key x 1 (PCIe Gen 4 [x4]), NVMe supported SATA 6Gb/s x 4, RAID 0, 1, 5, 10 support
USB	USB 3.2 (Gen 1x1) x 2 via Box Header x 1 USB 2.0 x 6 via Pin Header x 3 USB 3.2 (Gen 1x1) x 1 (Type-A, Vertical) USB 2.0 x 1 (Type-A, Vertical)
Display I/O	—
Audio I/O	Speaker Header x 1 Front Panel x 1
Serial Port	RS-232 x 5
PS/2 Port	PS/2 x 1
Parallel Port	—
DIO	8-bit Header x 1
Fan	CPU Fan Header (Smart Fan) x 1 3-pin Connector for System Fan x 2 (PWM Mode)
Power	24+8-pin ATX Header
Others	Chassis Intrusion x 1 AT/ATX Mode Select Jumper x 1 Clear CMOS Jumper x 1 Buzzer Onboard x 1 Nano SIM Card Slot x 1
OS	
OS Support	Windows® 11 64-bit Linux

Chapter 2

Motherboard Information

2.1 Before you Proceed

Take note of the following precautions before you install motherboard components or change any motherboard settings.



CAUTION!

- Unplug the power cord from the wall socket before touching any component.
 - Before handling components, use a grounded wrist strap or touch a safely grounded object or a metal object, such as the power supply case, to avoid damaging them due to static electricity.
 - Hold components by the edges to avoid touching the ICs on them.
 - Whenever you uninstall any component, place it on a grounded antistatic pad or in the bag that came with the component.
 - Before you install or remove any component, ensure that the ATX power supply is switched off or the power cord is detached from the power supply. Failure to do so may cause severe damage to the motherboard, peripherals, or components.
-

2.2 Motherboard Layout



Place four screws into the holes indicated by circles to secure the motherboard to the chassis



Do not overtighten the screws! Doing so can damage the motherboard

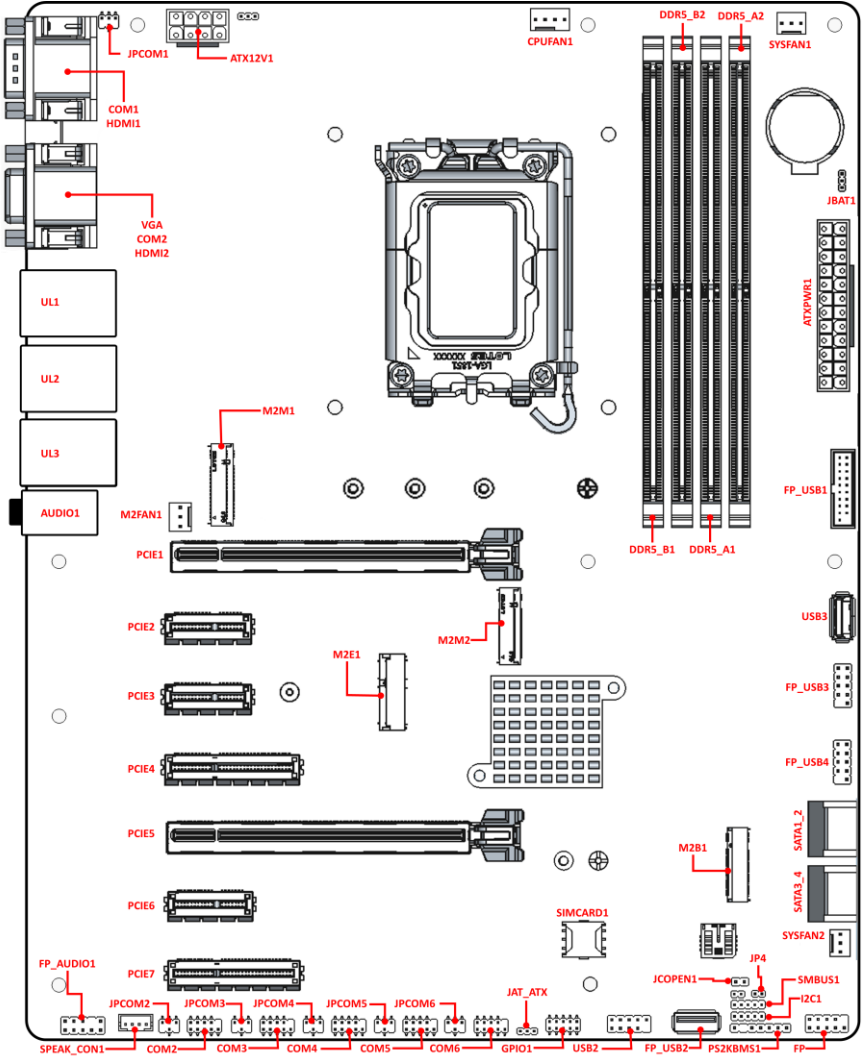

2.3 Central Processing Unit (CPU)

The motherboard comes with a surface mount LGA 1851 socket designed for Intel® Core™ Ultra Processors (Series 2) (formerly Arrow Lake-S).

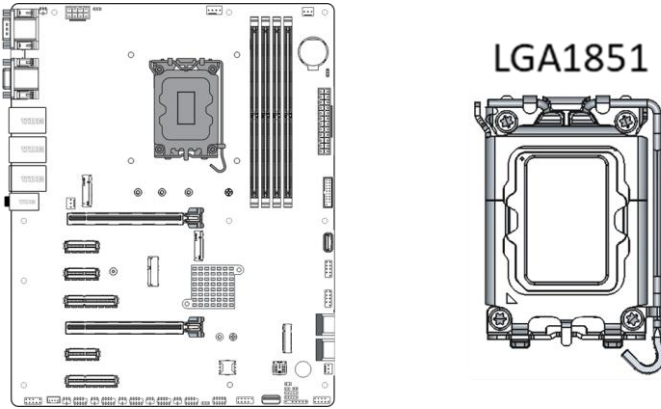

IMPORTANT: Unplug all power cables before installing the CPU.



CAUTION!

- Ensure that you install the correct CPU designed for LGA 1851 socket only. DO NOT install a CPU designed for other sockets on the LGA 1851 socket.
- The CPU fits in only one correct orientation. DO NOT force the CPU into the socket to prevent bending the connectors on the socket and damaging the CPU.
- Ensure that all power cables are unplugged before installing the CPU.
- Ensure that the PnP cap is on the socket and the socket contacts are not bent. Contact your retailer immediately if the PnP cap is missing, or if you see any damage to the PnP cap/socket contacts/motherboard components. ASUS will shoulder the cost of repair only if the damage is shipment/transit-related.
- Keep the cap after installing the motherboard. ASUS will process Return Merchandise Authorization (RMA) requests only if the motherboard comes with the cap on the LGA 1851 socket.
- The product warranty does not cover damage to the socket contacts resulting from incorrect CPU installation/removal, or misplacement/loss/incorrect removal of the PnP cap.

2.3.1 Installing the CPU

CAUTION!



- Ensure that you install the correct CPU designed for LGA 1851 socket only. DO NOT install a CPU designed for other sockets on the LGA 1851 socket.
 - ASUS will not cover damages resulting from incorrect CPU installation/removal, incorrect CPU orientation/placement, or other damages resulting from negligence by the user.
-

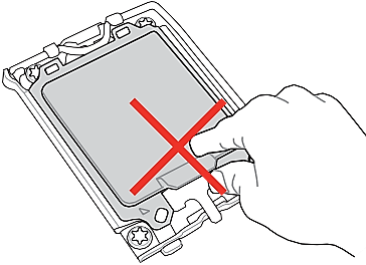

CAUTION!

Take caution when lifting the load lever, ensure to hold onto the load lever when releasing the load lever. Letting go of the load lever immediately after releasing it may cause the load lever to spring back and cause damage to your motherboard.

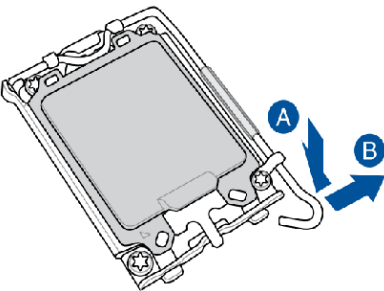

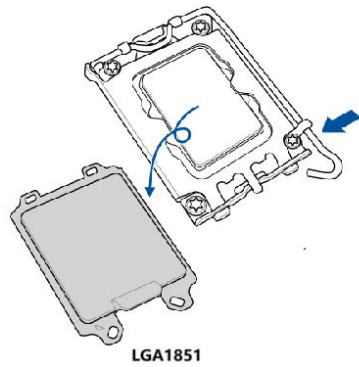
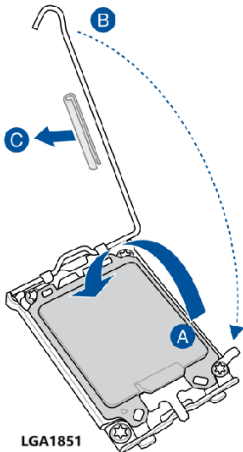
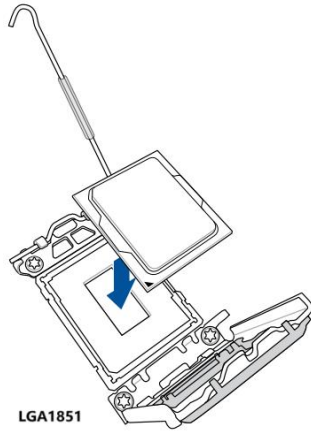
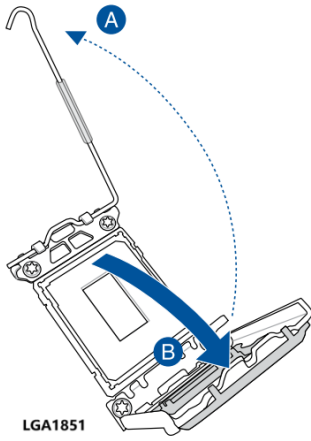

2.3.2 CPU Heatsink and Fan Assembly Installation

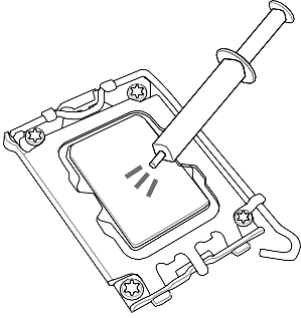

IMPORTANT: Apply Thermal Interface Material to the CPU cooling system and CPU before you install the cooling system, if necessary

CAUTION! Ensure to remove the CPU Socket lever protector on the lever latch before installing the cooling system, failure to do so may cause damages to your system.

Installing CPU Heatsink and Fan:

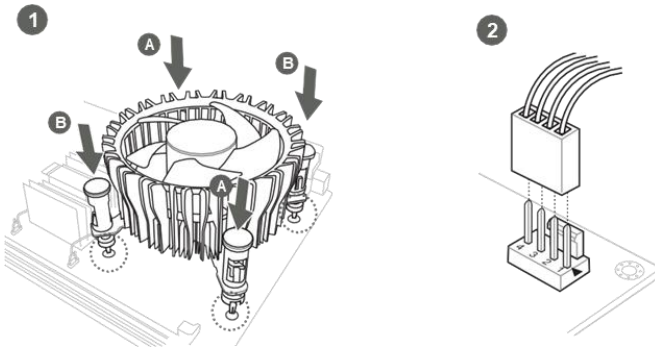

Uninstalling the CPU Heatsink and Fan:

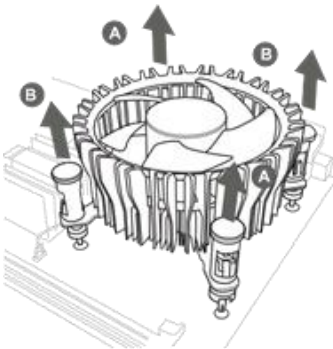

2.3.3 System Memory

The motherboard comes with Unbuffered Dual Inline Memory Module/Clocked Unbuffered Dual In-line Memory Module (U/CU-DIMM) slots designed for DDR5 (Double Data Rate 5) memory modules.



CAUTION! A DDR5 memory module is notched differently from a DDR, DDR2, or DDR3 module. DO NOT install a DDR, DDR2, or DDR3 memory module to the DDR4 slot.

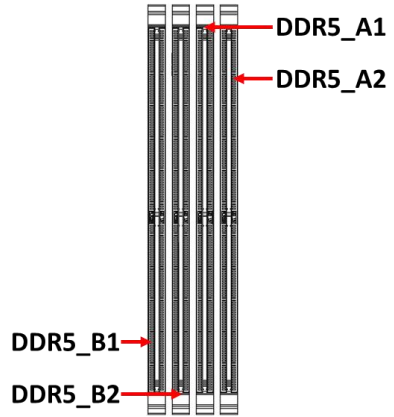
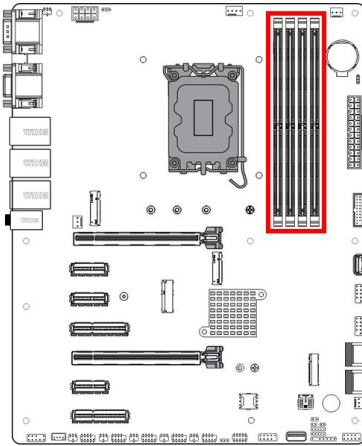

2.3.4 DIMM Installation

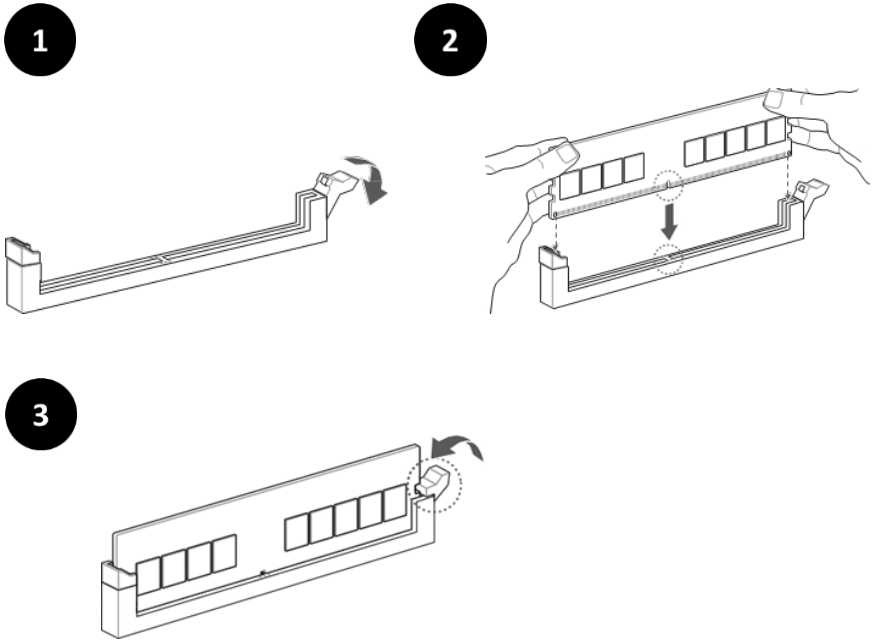

DIMM Removal:

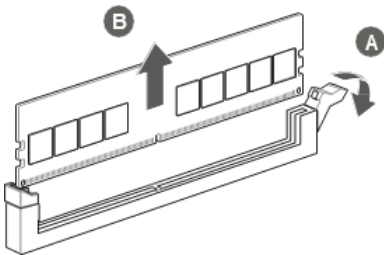

2.4 Jumpers

Please refer to the table below for all of the board's jumpers that you can configure for your application

Label	Function
JP4	GPIO/80 Port Function Select
JAT_ATX	ATX Mode/AT Mode Select
JBAT1	Clear CMOS Function Select
JCOPEN1	Case Open Function Select
JPCOM1	COM 1 Header Pin-9 Function Select
JPCOM2	COM 2 Header Pin-9 Function Select
JPCOM3	COM 3 Header Pin-9 Function Select
JPCOM4	COM 4 Header Pin-9 Function Select
JPCOM5	COM 5 Header Pin-9 Function Select
JPCOM6	COM 6 Header Pin-9 Function Select

2.4.1 GPIO/80 Port Function Select (JP4)

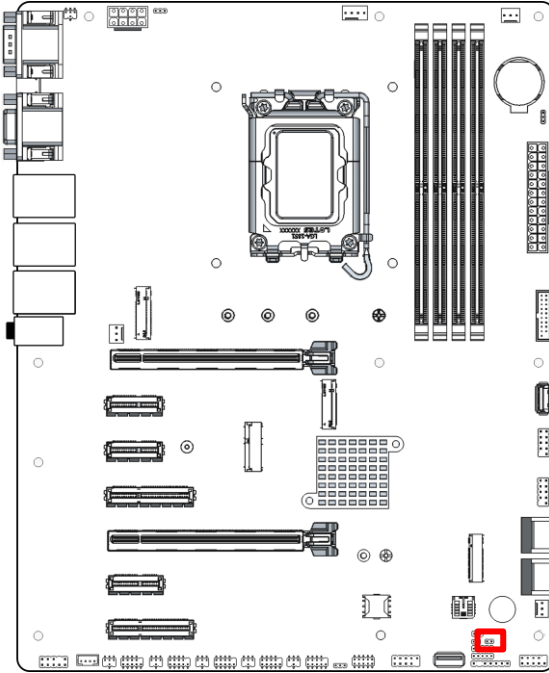

1



1-2 Open:
GPIO_CON=80 Port

1



1-2 Closed:
GPIO_CON=GPIO Port

2.4.2 ATX Mode/AT Mode Select (JAT_ATX)

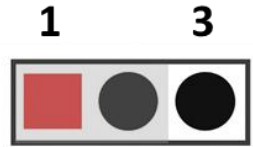
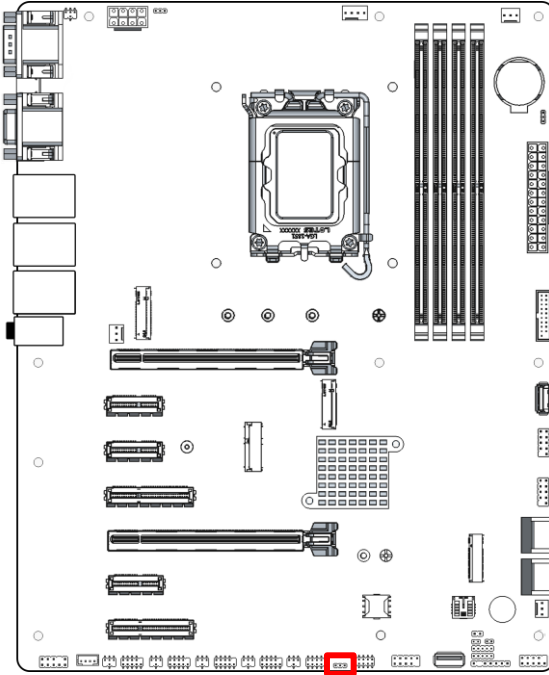

**1-2 Closed:
ATX Mode Selected**

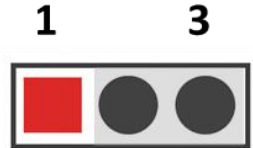

**2-3 Closed:
AT Mode Selected**

2.4.3 Clear CMOS Function Select (JBAT1)

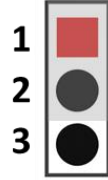
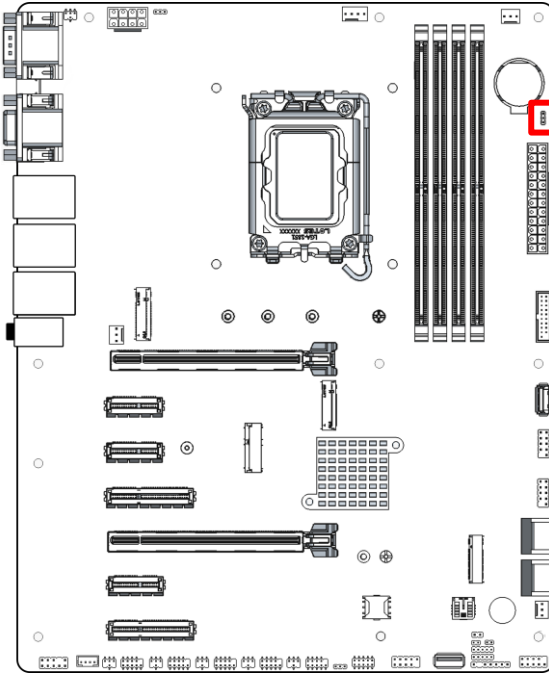

1-2 Closed: Normal

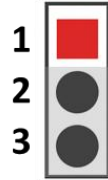

2-3 Closed: Clear CMOS

2.4.4 Case Open Function Select (JCOPEN1)

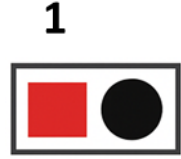
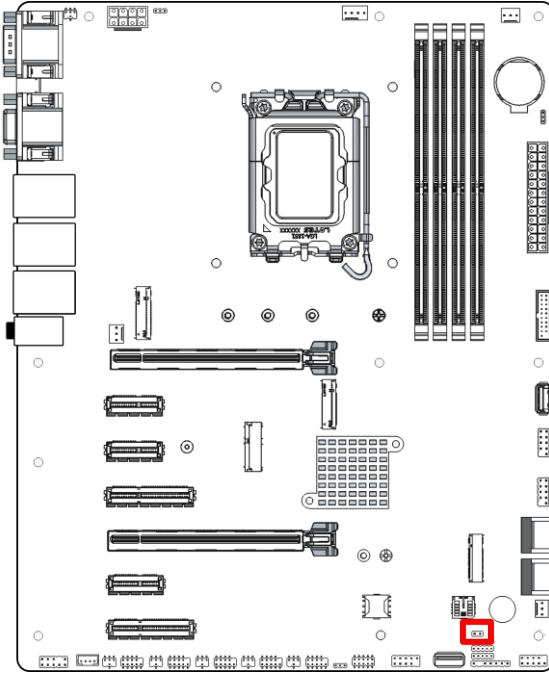

CASE OPEN

GND

Default: Open

2.4.5 COM 1 Header Pin-9 Function Select (JPCOM1)

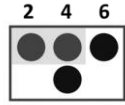
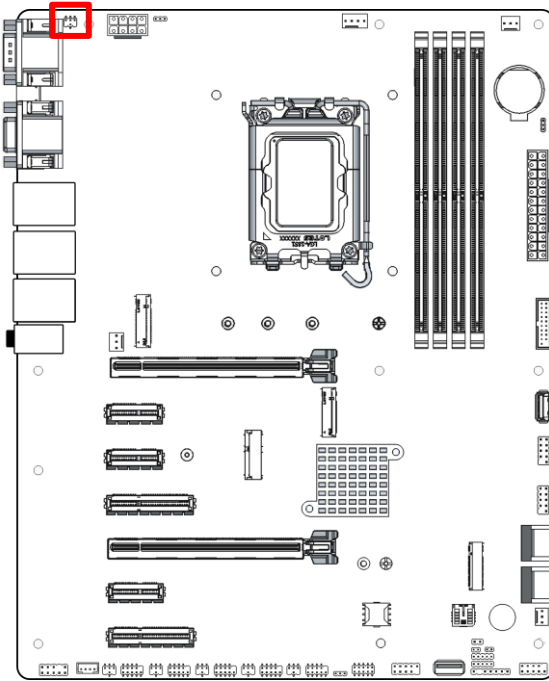

2-4 Closed:
PIN9 = RS-232

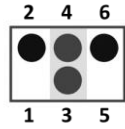

3-4 Closed:
PIN9 = +5V

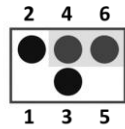

4-6 Closed:
PIN9 = +12V

2.4.6 COM 2 Header Pin-9 Function Select (JPCOM2)

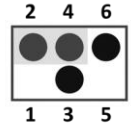
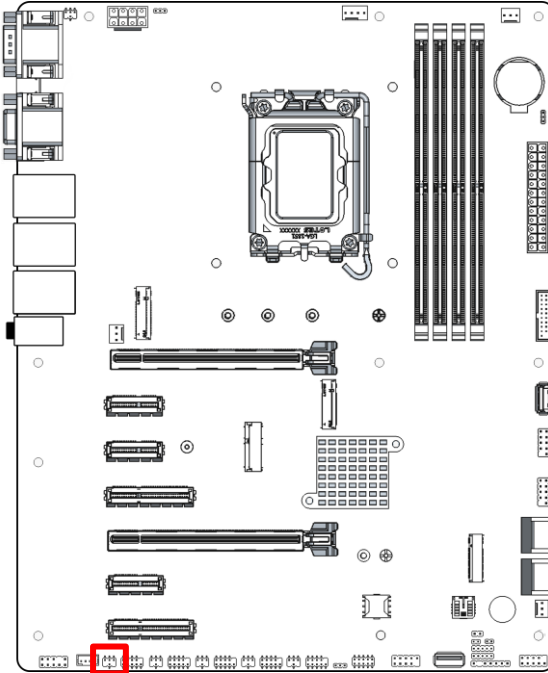

2-4 Closed:
PIN9 = RS-232

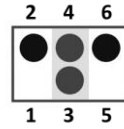

3-4 Closed:
PIN9 = +5V

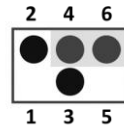

4-6 Closed:
PIN9 = +12V

2.4.7 COM 3 Header Pin-9 Function Select (JPCOM3)

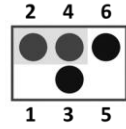
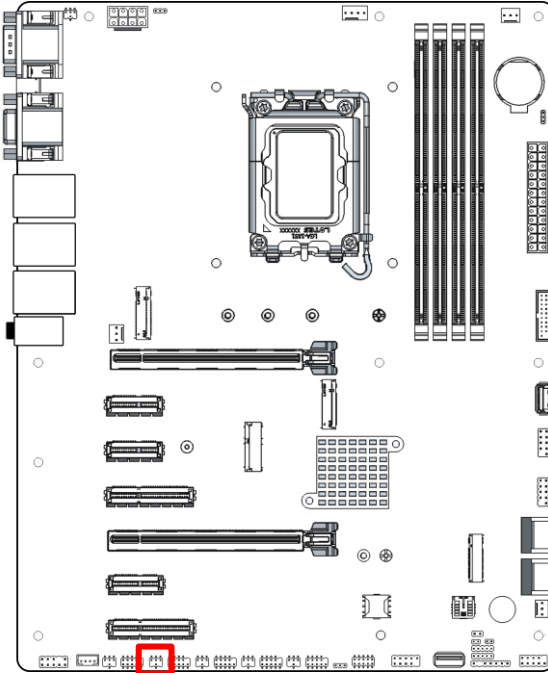

2-4 Closed:
PIN9 = RS-232

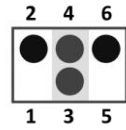

3-4 Closed:
PIN9 = +5V

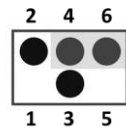

4-6 Closed:
PIN9 = +12V

2.4.8 COM 4 Header Pin-9 Function Select (JPCOM4)

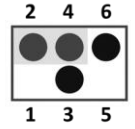
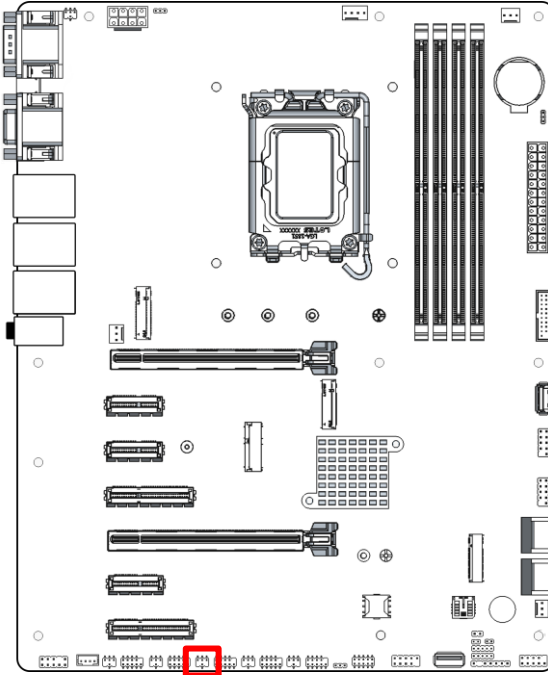

2-4 Closed:
PIN9 = RS-232

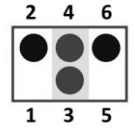

3-4 Closed:
PIN9 = +5V

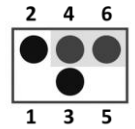

4-6 Closed:
PIN9 = +12V

2.4.9 COM 5 Header Pin-9 Function Select (JPCOM5)

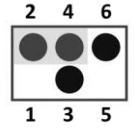
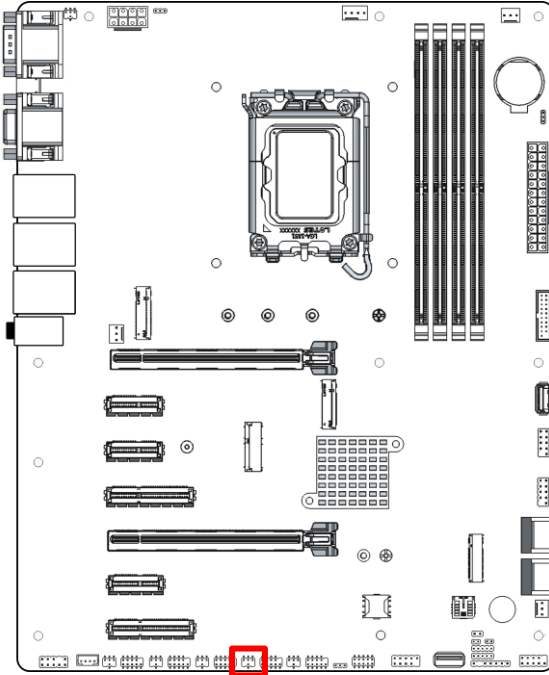

2-4 Closed:
PIN9 = RS-232

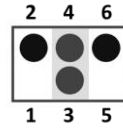

3-4 Closed:
PIN9 = +5V

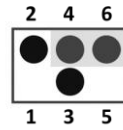

4-6 Closed:
PIN9 = +12V

2.4.10 COM 6 Header Pin-9 Function Select (JPCOM6)

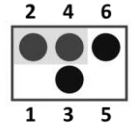
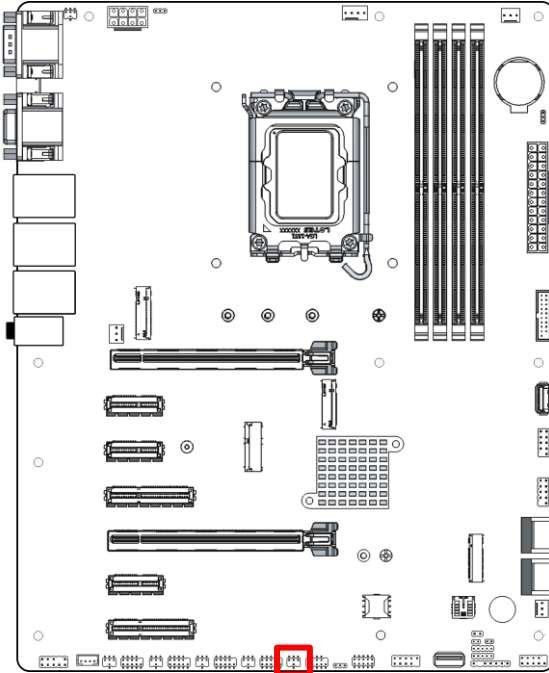

**2-4 Closed:
PIN9 = RS-232**

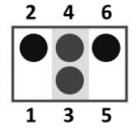

**3-4 Closed:
PIN9 = +5V**

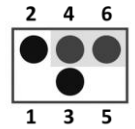

**4-6 Closed:
PIN9 = +12V**

2.5 List of Connectors

Please refer to the table below for all of the board's connectors that you can configure for your application.

Rear I/O Ports

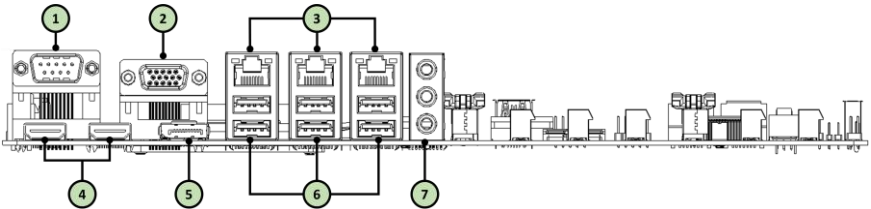

Label	Function
1	COM
2	VGA
3	RJ-45 LAN x 3
4	HDMI x 2
5	DP
6	USB 3.2 x 6
7	Line-In/Line-Out/Mic-In

Internal Connectors

Label	Function
UL1	2.5GbE RJ-45 LAN/USB 3.2 Gen 2 Port Connector
UL2	2.5GbE RJ-45 LAN/USB 3.2 Gen 2 Port Connector
UL3	2.5GbE RJ-45 LAN/USB 3.2 Gen 2 Port Connector
HDMI1	HDMI 2.1 TMDS Connector
HDMI2	HDMI 2.1 TMDS Connector
DP1	DP 1.4a Connector
VGA	VGA Connector
CPUFAN1	CPU Fan Connector
SYSFAN1	System Fan Connector
SYSFAN2	System Fan Connector
M2FAN1	M2M1 Fan Connector
SPEAK_CON1	3W Amplifier Wafer
I2C1	I2C Header
SMBUS1	SMBus Header
FP_USB1	USB 3.2 Gen 1 Port Header

Label	Function
FP_USB2	USB 2.0 Port Header
FP_USB3	USB 2.0 Port Header
FP_USB4	USB 2.0 Port Header
USB2	USB 2.0 Vertical Type-A Connector
USB3	USB 3.2 Gen 1 Vertical Type-A Connector
PS2KBMS1	PS/2 Keyboard and Mouse Header
FP_AUDIO1	Front Panel Audio Header
FP	Front Panel Header (PWR LED/HDD LED/Power Button/Reset)
SATA1_2	SATA Connector
SATA3_4	SATA Connector
COM1	Serial Port (RS-232/422/485) Connector
COM2	RS-232 Serial Port Header
COM3	RS-232 Serial Port Header
COM4	RS-232 Serial Port Header
COM5	RS-232 Serial Port Header
COM6	RS-232 Serial Port Header
GPIO1	8-Bit GPIO Port/80 Port Header
SIMCARD1	Nano SIM Card Socket
M2M1	M.2 2242/2260/2280/22110 M-Key Slot
M2M2	M.2 2280 M-Key Slot
M2B1	M.2 3042/3052 B-Key Slot
M2E1	M.2 2230 E-Key Slot
DDR5_A1	DDR5 U-DIMM Socket
DDR5_A2	DDR5 U-DIMM Socket
DDR5_B1	DDR5 U-DIMM Socket
DDR5_B2	DDR5 U-DIMM Socket
PCIE1	PCIe Gen 5 [x16] Slot
PCIE2	PCIe Gen 4 [x1] Slot
PCIE3	PCIe Gen 4 [x1] Slot
PCIE4	PCIe Gen 4 [x4] Slot
PCIE5	PCIe Gen 5 [x16] Slot
PCIE6	PCIe Gen4 [x1] Slot
PCIE7	PCIe Gen 4 [x4] Slot
AUDIO1	Audio Line-In/Line-Out/Mic Combo Connector
ATXPWR1	24-Pin ATX Power Supply Connector
ATX12V1	8-Pin ATX 12V Power Connector

2.5.1 2.5GbE LAN/USB 3.2 Gen 2 Port Connector (UL1)

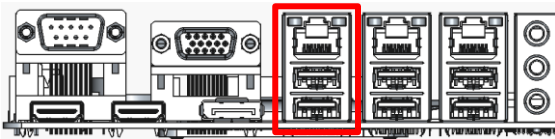
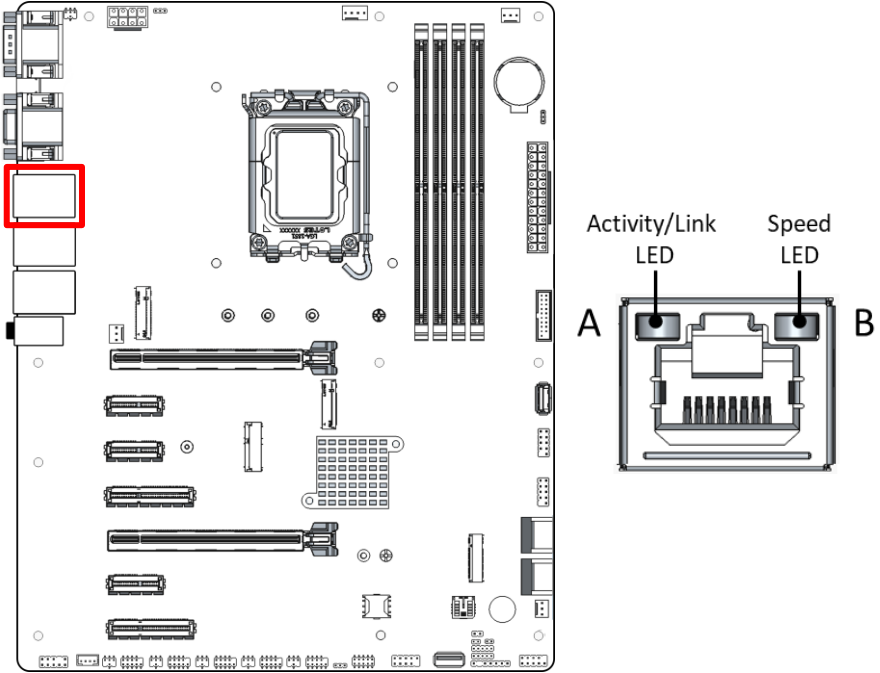

A: Activity/Link LED		B: Speed LED	
Status	Description	Status	Description
Off	No Link	Off	10/100Mbps
Blinking	Data Activity	Orange	1000Mbps
On	Link	Green	2.5Gbps

- 2.5Gbps high-speed transmission rate is only supported over CAT 5e UTP cable.
- Supports 5 V output with up to 900 mA ×2 current.

2.5.2 2.5GbE LAN/USB 3.2 Gen 2 Port Connector (UL2)

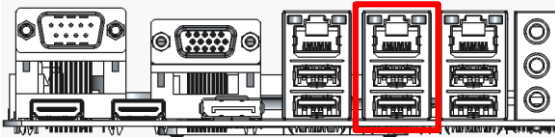
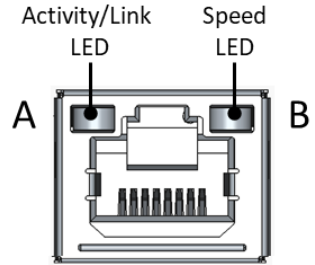
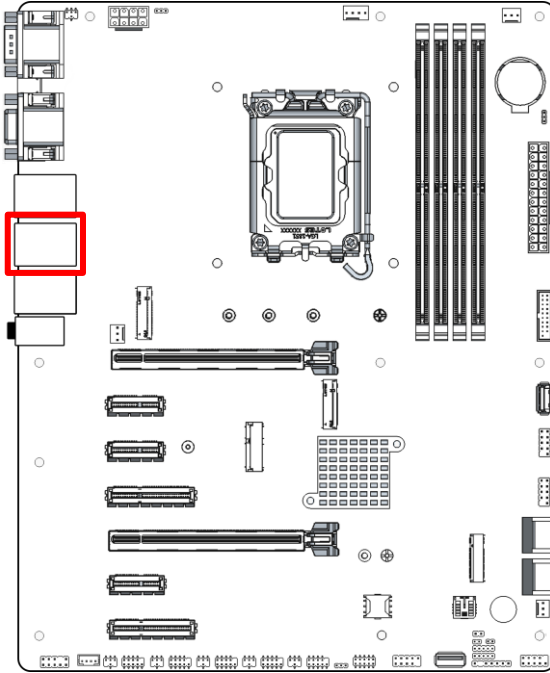

A: Activity/Link LED		B: Speed LED	
Status	Description	Status	Description
Off	No Link	Off	10/100Mbps
Blinking	Data Activity	Orange	1000Mbps
On	Link	Green	2.5Gbps

- 2.5Gbps high-speed transmission rate is only supported over CAT 5e UTP cable.
- Supports 5 V output with up to 900 mA ×2 current.

2.5.3 2.5GbE LAN/USB 3.2 Gen 2 Port Connector (UL3)

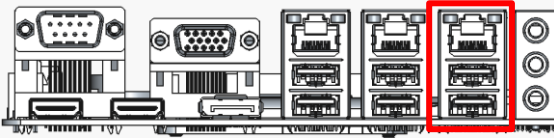
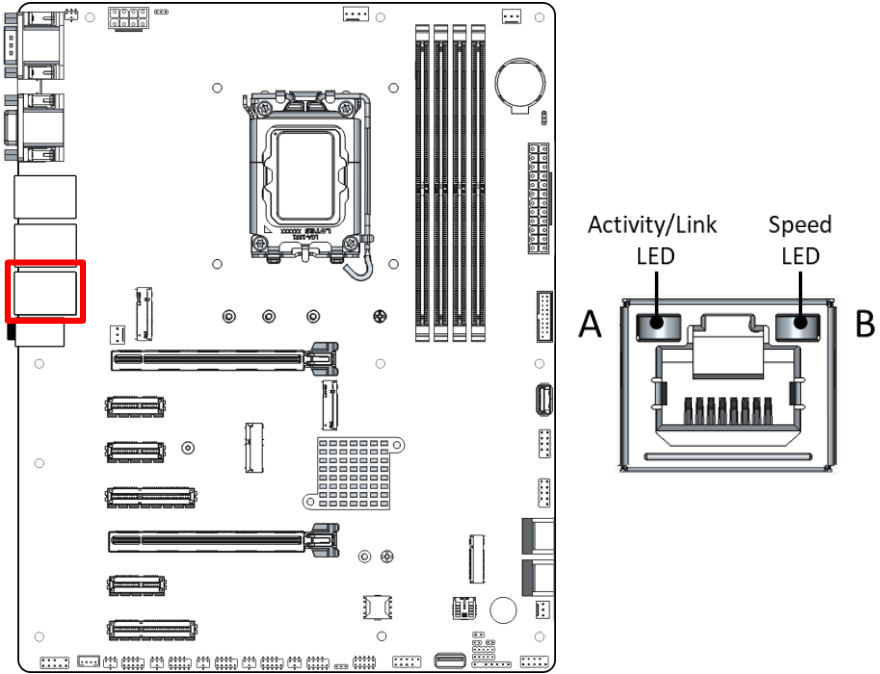

A: Activity/Link LED		B: Speed LED	
Status	Description	Status	Description
Off	No Link	Off	10/100Mbps
Blinking	Data Activity	Orange	1000Mbps
On	Link	Green	2.5Gbps

- 2.5Gbps high-speed transmission rate is only supported over CAT 5e UTP cable.
- Supports 5 V output with up to 900 mA ×2 current.

2.5.4 HDMI 2.1 TMD5 Connectors (HDMI1/HDMI2)



Note: Standard specification.

2.5.5 Display Port (DP1)



Note: Standard specification.

2.5.6 VGA Connector (VGA)

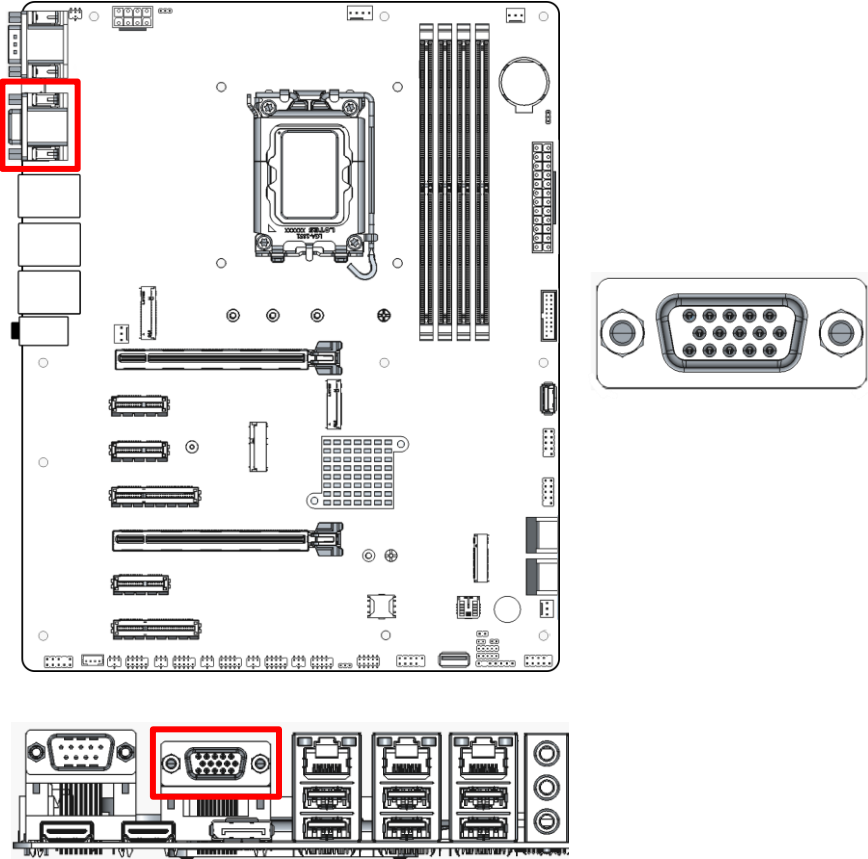

Note: Standard specification.

2.5.7 CPU Fan Connector (CPUFAN1)

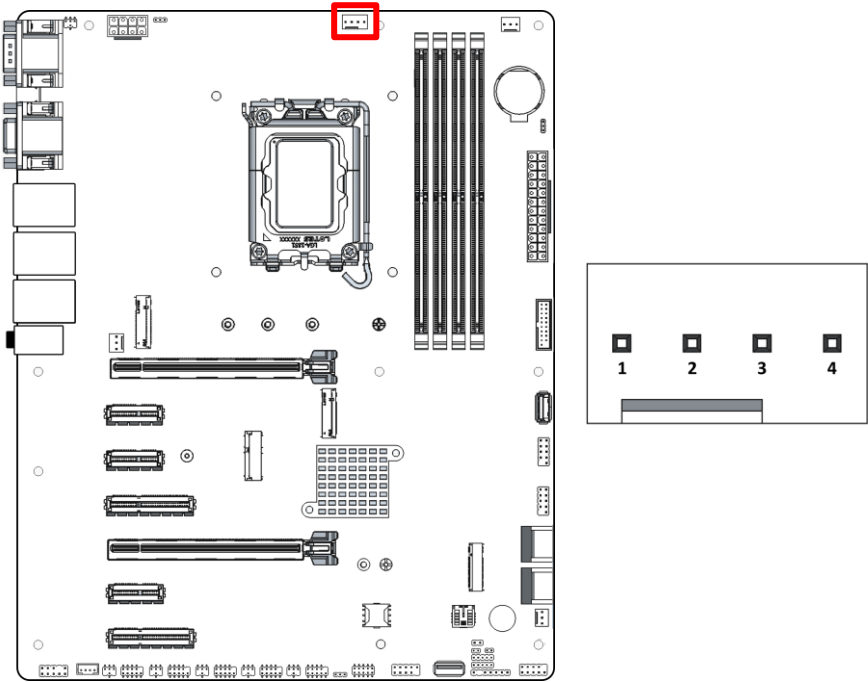

Pin	Signal
1	GND
2	+12V Fan Power
3	Fan Speed
4	Control

- Supplies 12 V with a maximum fan current of 1.5 A.

2.5.8 System Fan Connector (SYSFAN1)

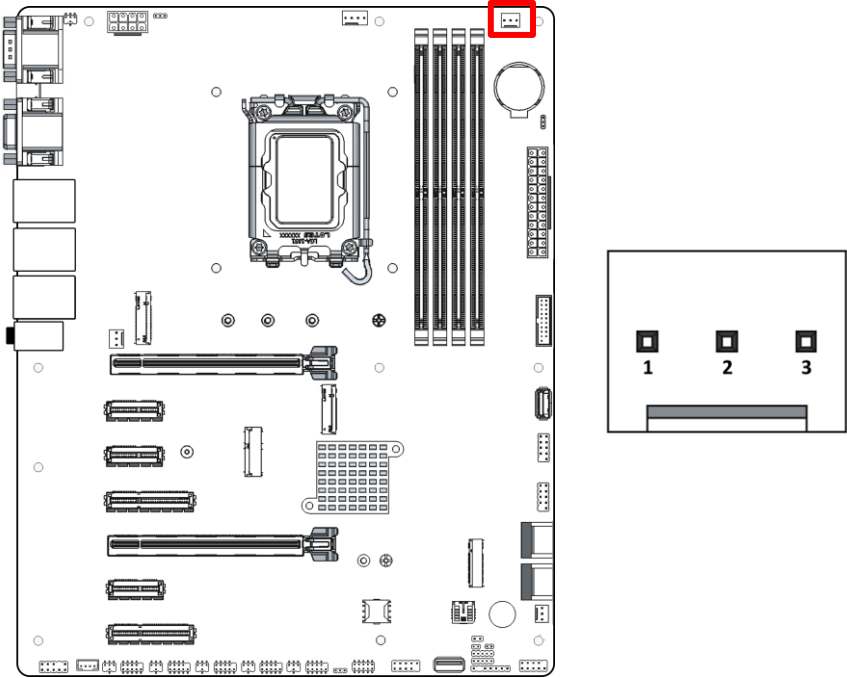

Pin	Signal
1	GND
2	+12V Fan Power
3	Fan Speed

- Supplies 12 V with a maximum fan current of 1.5 A.

2.5.9 System Fan Connector (SYSFAN2)

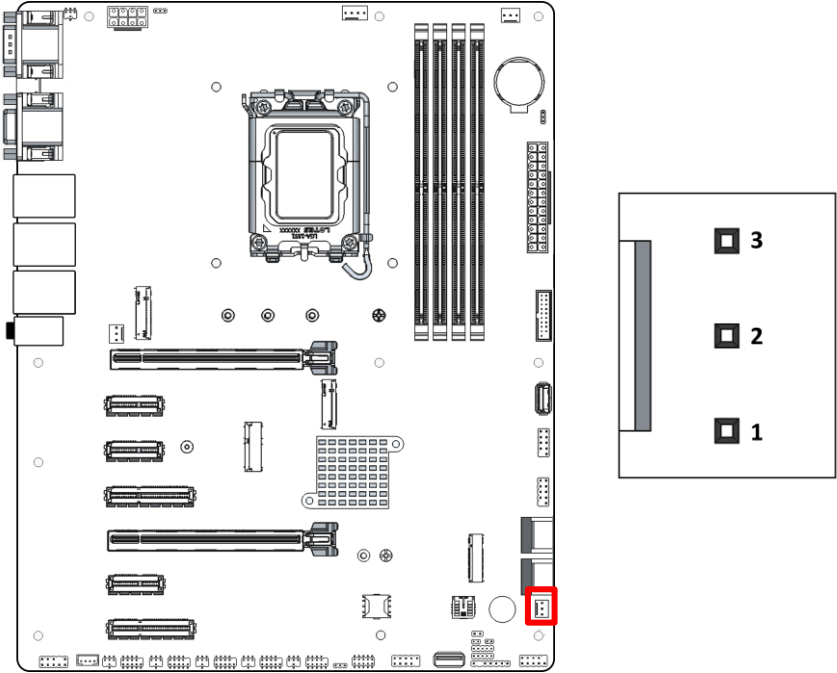

Pin	Signal
1	GND
2	+12V Fan Power
3	Fan Speed

- Supplies 12 V with a maximum fan current of 1.5 A.

2.5.10 M2M1 Fan Connector (M2FAN1)

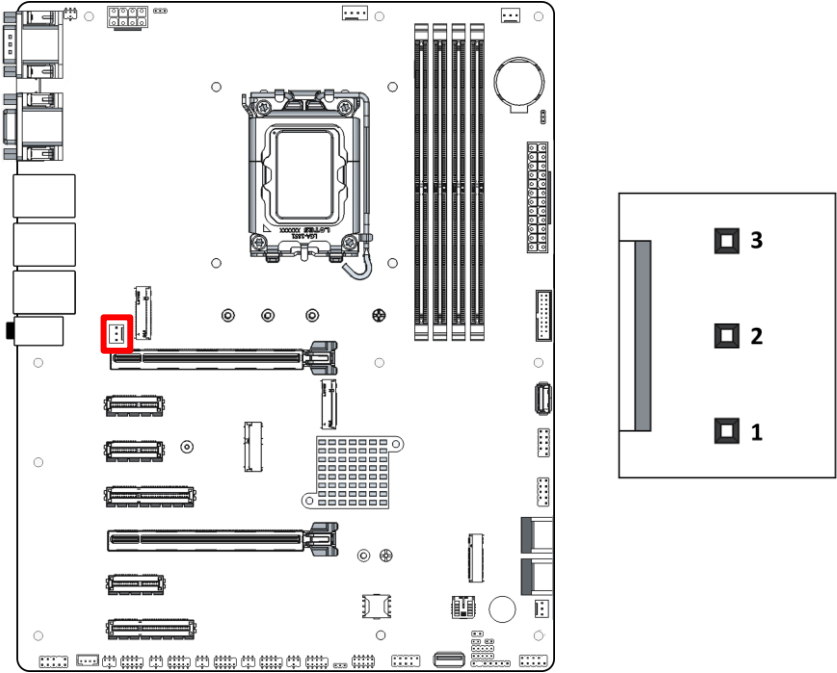

Pin	Signal
1	GND
2	+12V Fan Power
3	NC

- Supplies 12 V with a maximum current of 1 A.

2.5.11 3W Amplifier Wafer (SPEAK_CON1)

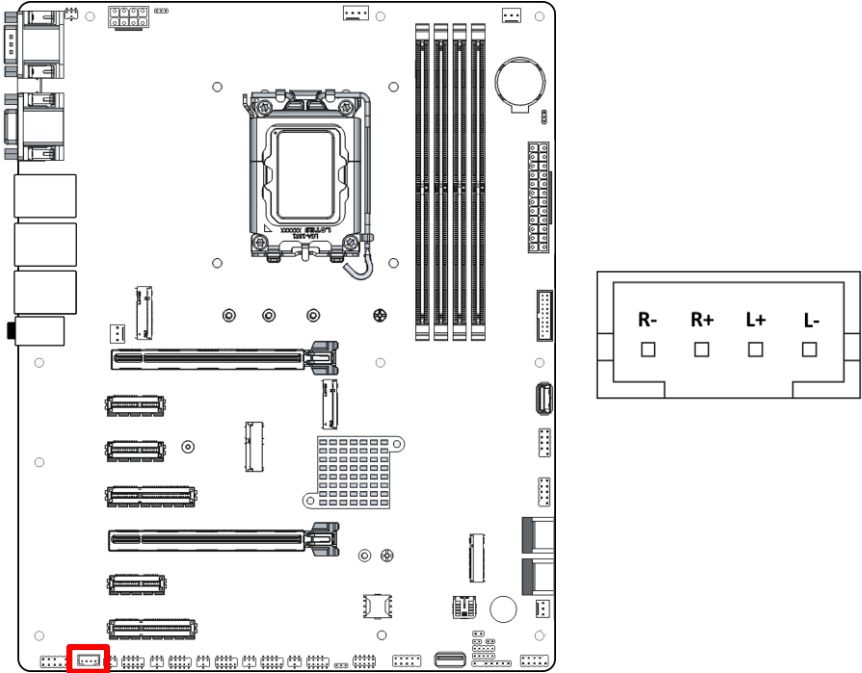

2.5.12 I2C Header (I2C1)

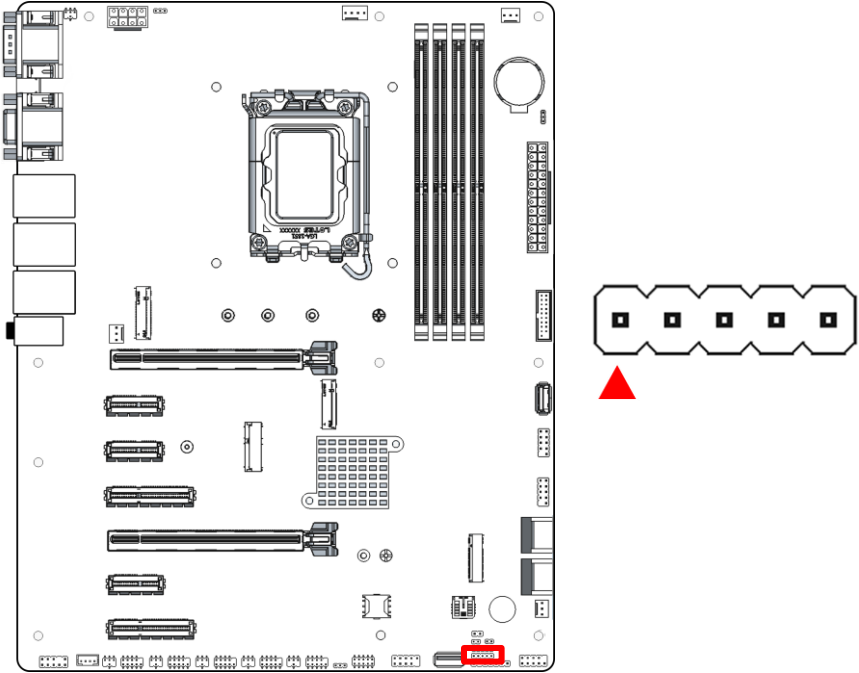

Pin	Signal	Pin	Signal
1	I2C_SCL	2	I2C_SDA
3	-	4	GND
5	3VSB		

- Operates at 3.3 V with up to 500 mA current support.

2.5.13 SMBus Header (SMBUS1)

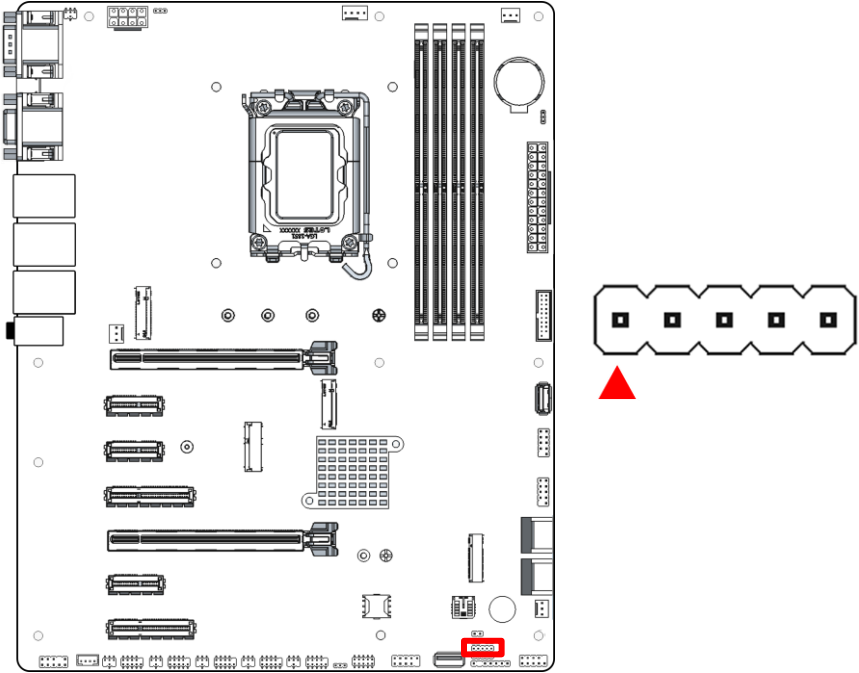

Pin	Signal	Pin	Signal
1	SMBUS_CLK	2	SMBUS_DATA
3	SMBUS_ALERT	4	GND
5	VCC3		

- Operates at 3.3 V with up to 500 mA current support.

2.5.14 USB 3.2 Gen 1 Port Header (FP_USB1)

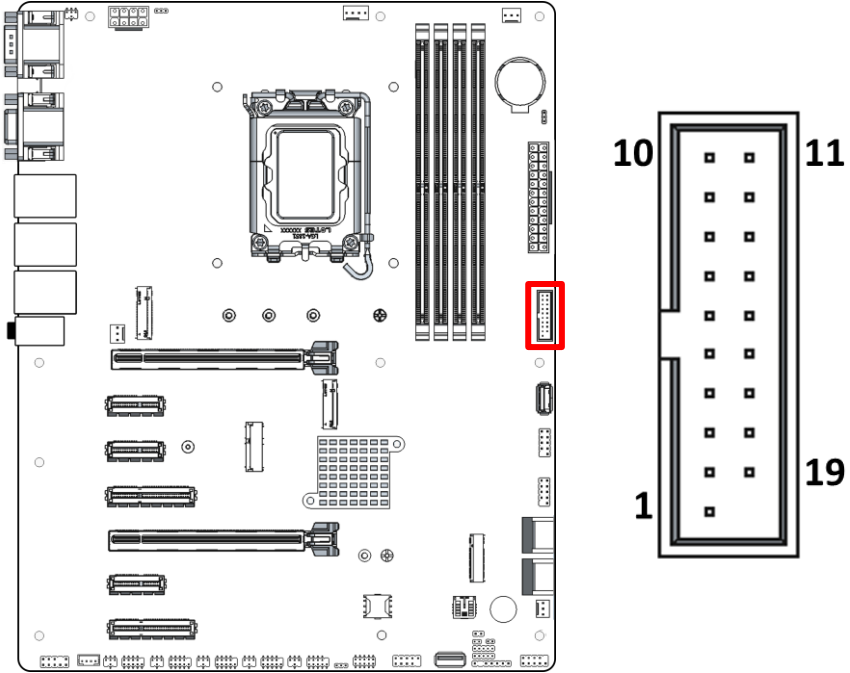

Pin	Signal	Pin	Signal
1	VBUS_5V	2	SSRX1-
3	SSRX1+	4	GND0
5	SSTX1-	6	SSTX1+
7	GND1	8	D-
9	D+	10	NC
11	D2+	12	D2-
13	GND2	14	SSTX2+
15	SSTX2-	16	GND3
17	SSRX2+	18	SSRX2-
19	VBUS_5V		

- Supports 5 V output with up to 900 mA ×2 current.

2.5.15 USB 2.0 Port Header (FP_USB2)

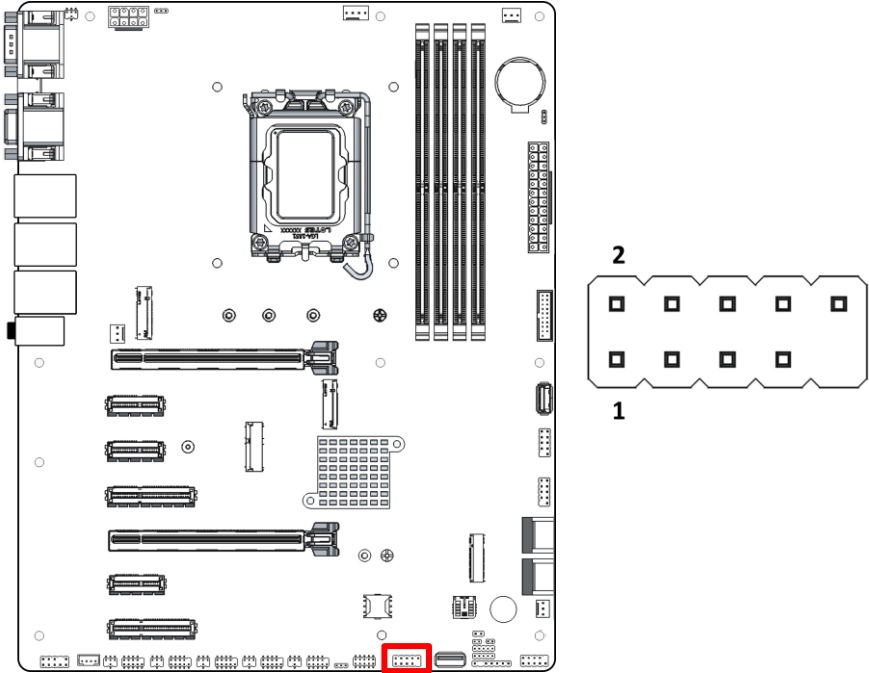

Pin	Signal	Pin	Signal
1	VCC	2	VCC
3	-DATA	4	-DATA
5	+DATA	6	+DATA
7	GND	8	GND
9	NC		

- Supports 5 V output with up to 500 mA ×2 current.

2.5.16 USB 2.0 Port Headers (FP_USB3/FP_USB4)

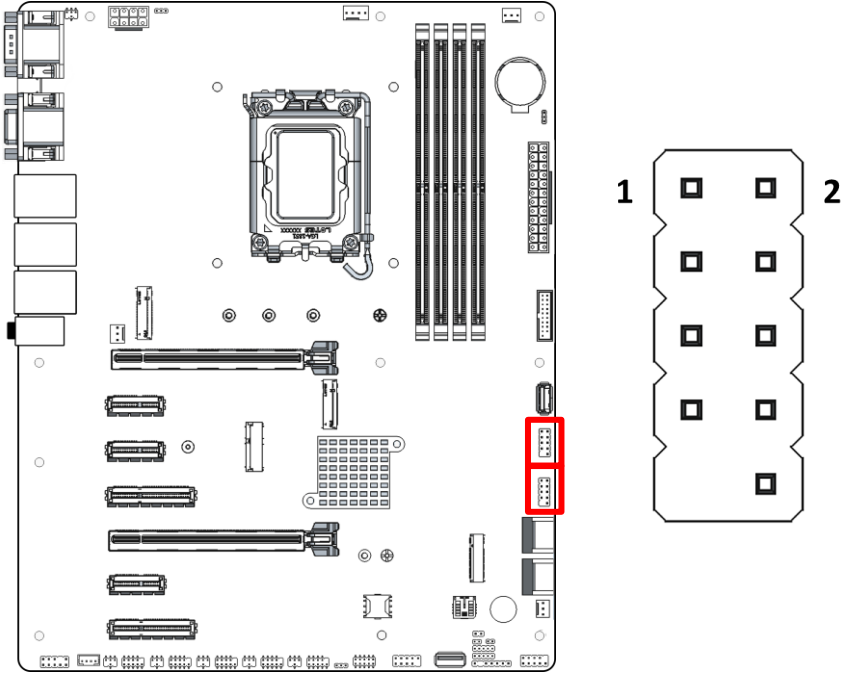

Pin	Signal	Pin	Signal
1	VCC	2	VCC
3	-DATA	4	-DATA
5	+DATA	6	+DATA
7	GND	8	GND
9	NC		

- Supports 5 V output with up to 500 mA ×2 current.

2.5.17 USB 2.0 Vertical Type-A Connectors (USB2/USB3)

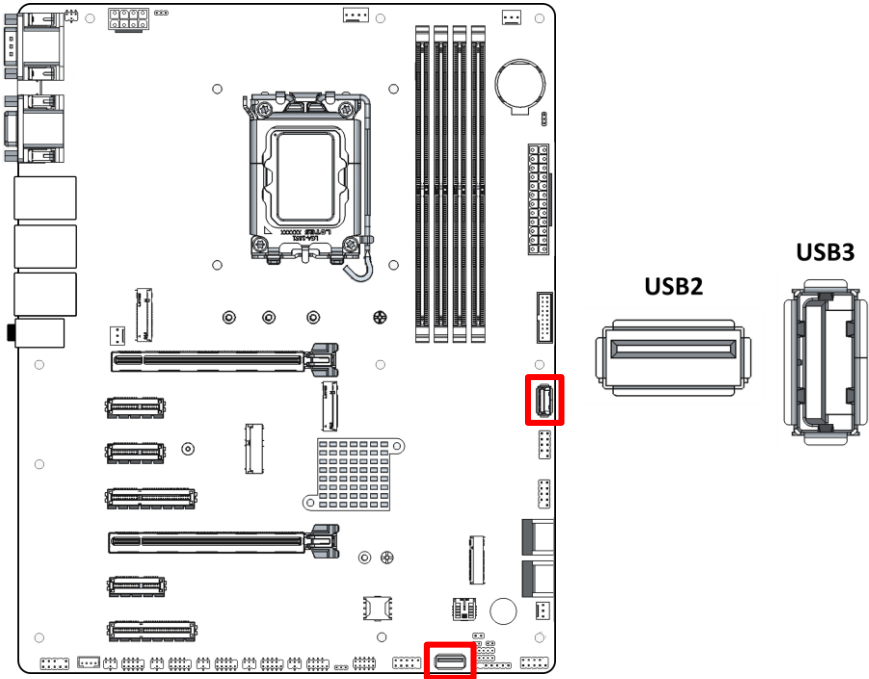

- USB2: Provides 5 V output with a maximum current of 500 mA.
- USB3: Provides 5 V output with a maximum current of 900 mA.

2.5.18 PS/2 Keyboard and Mouse Header (PS2KBMS1)

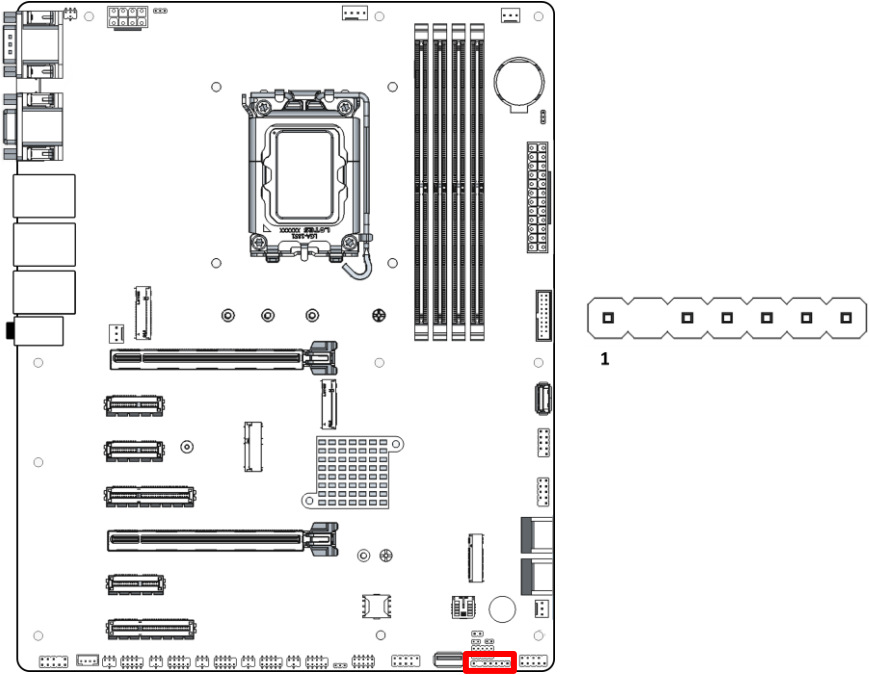

Pin	Signal	Pin	Signal
1	VCC5V	-	-
3	KB_DATA-	4	KB_CLK-
5	GND	6	MS_CLK-
7	MS_DATA		

2.5.19 Front Panel Audio Header (FP_AUDIO1)

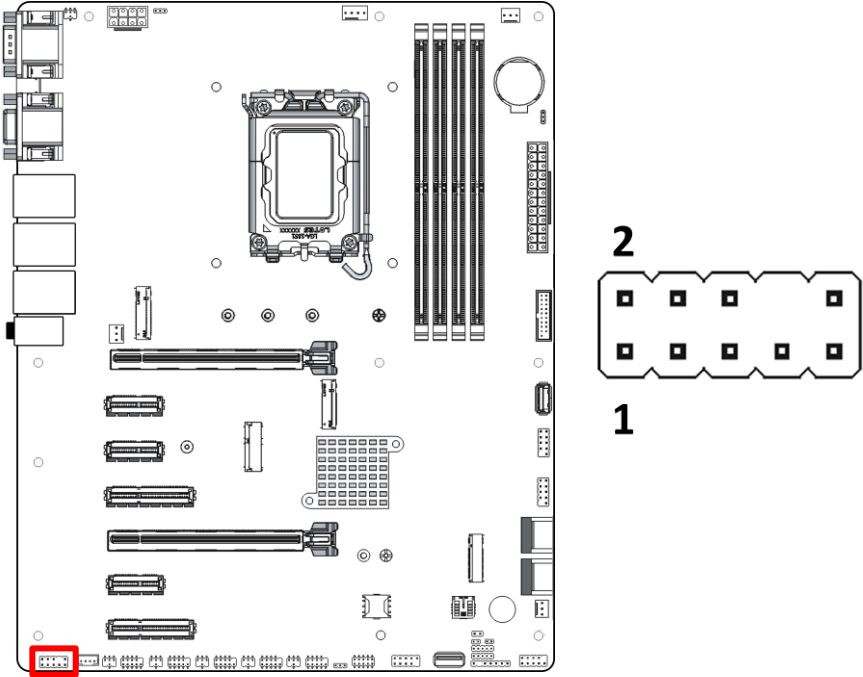

Pin	Signal	Pin	Signal
1	MIC2_L	2	GND
3	MIC2_R	4	AUDIO_JD
5	LINE_OUT_R	6	MIC_JD
7	SENSE	-	-
9	LINE_OUT2_L	10	LINE_OUT_JD

2.5.20 Front Panel Header (FP)

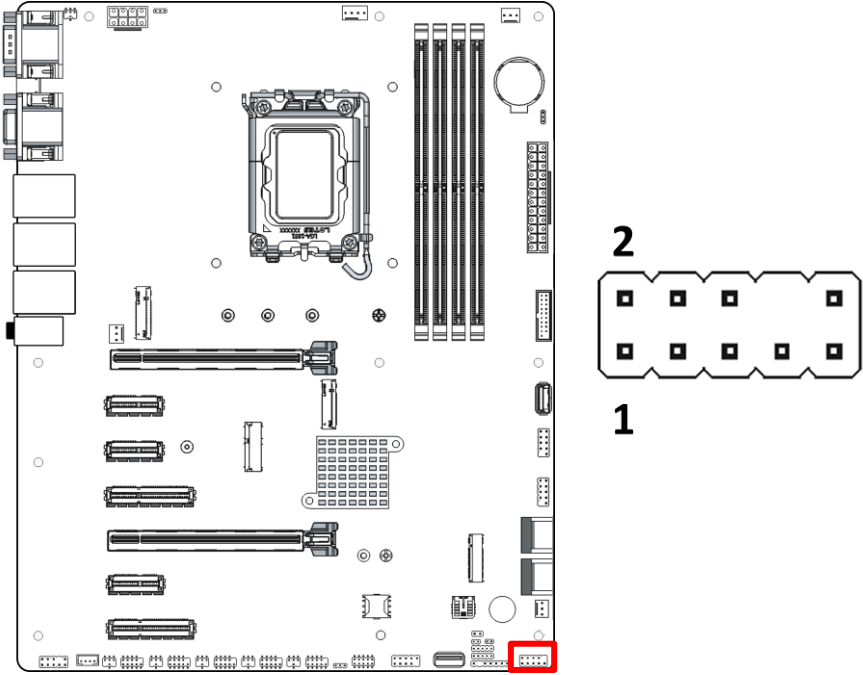

Pin	Signal	Pin	Signal
1	HDDLED+	2	PWRLED+
3	HDDLED-	4	PWRLED-
5	GND	6	PWRBT
7	RSTSW	8	GND
9	VCC	-	-

- Provides 5 V output with a maximum current of 1 A.

2.5.21 SATA Connector (SATA1_2/SATA3_4)

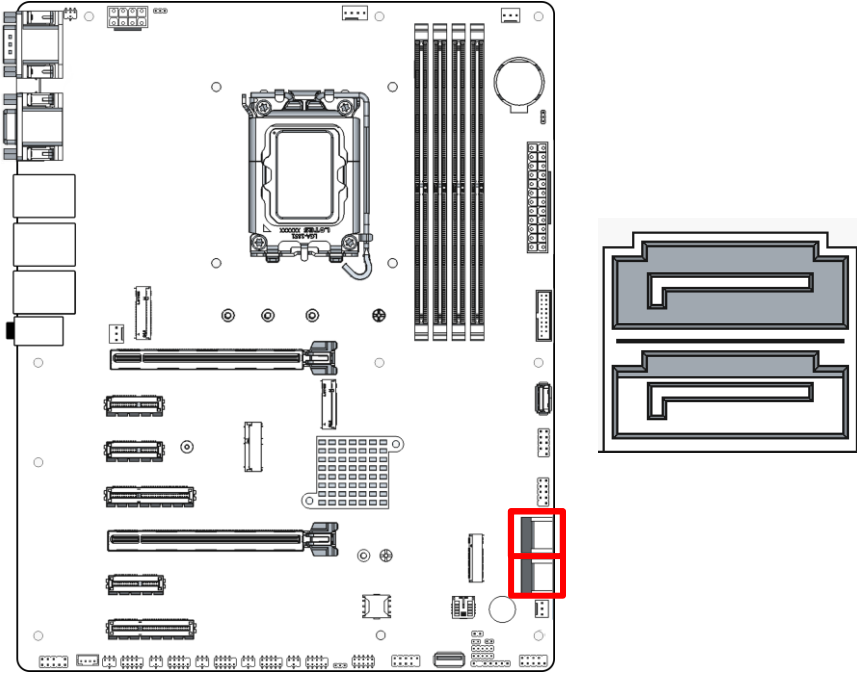

Note: Standard specifications.

2.5.22 Serial Port Connector (COM1)

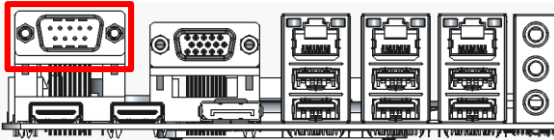
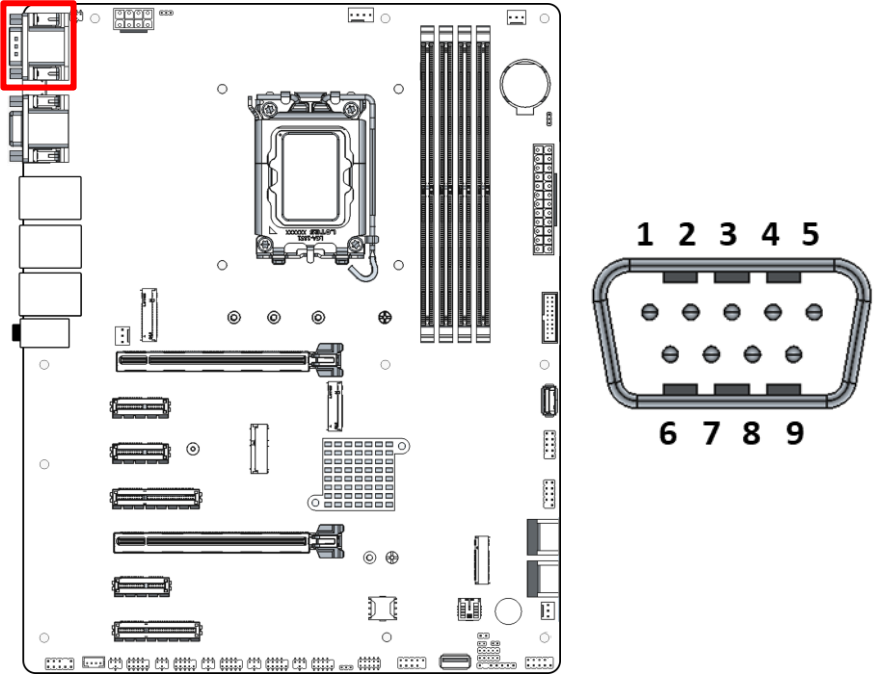

RS-232			
Pin	Signal	Pin	Signal
1	RS232 DCD#	2	RS232 SIN
3	RS232 SOUT	4	RS232 DTR#
5	GND	6	RS232 DSR#
7	RS232 RTS#	8	RS232 CTS#
9	RS232 RI#	-	-

RS-422			
Pin	Signal	Pin	Signal
1	RS422 TX(B)	2	RS422 TX(A)
3	RS422 RX(A)	4	RS422 RX(B)
5	GND	6	-
7	-	8	-
9	-	-	-
RS-485			
Pin	Signal	Pin	Signal
1	RS485 D-(B)	2	RS485 D+(A)
3	-	4	-
5	GND	6	-
7	-	8	-
9	-	-	-

- Supports 5 V / 12 V output with a maximum current of 500 mA.

2.5.23 RS-232 Serial Port Header (COM2 – COM6)

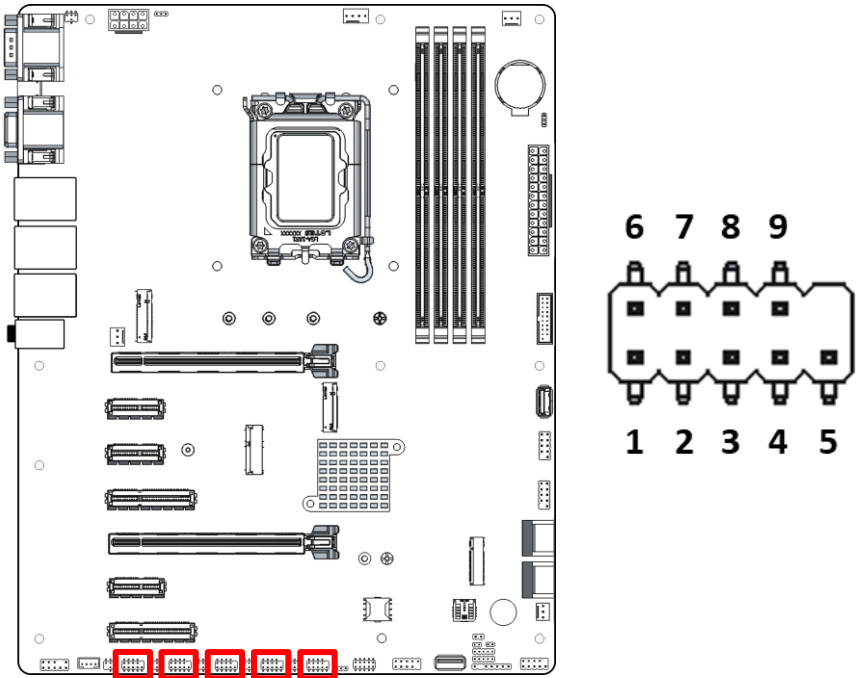

Pin	Signal	Pin	Signal
1	DCD	2	SIN
3	SOUT	4	DTR
5	GND	6	DSR
7	RTS	8	CTS
9	RI	-	-

- Supports 5 V / 12 V output with a maximum current of 500 mA.

2.5.24 GPIO Port Header (GPIO1)

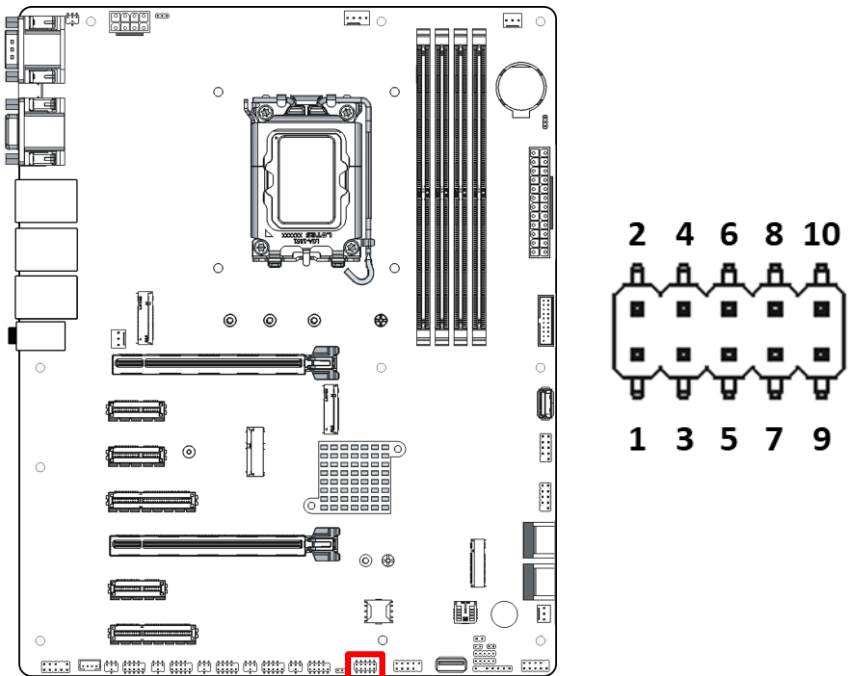

Pin	Signal	Pin	Signal
1	SIO_GPIO80	2	SIO_GPIO81
3	SIO_GPIO82	4	SIO_GPIO83
5	SIO_GPIO84	6	SIO_GPIO85

Pin	Signal	Pin	Signal
7	SIO_GPIO86	8	SIO_GPIO87
9	GND	10	VCC

- Provides 5 V output with a maximum current of 1 A.

2.5.25 Nano SIM Card Socket (SIMCARD1)

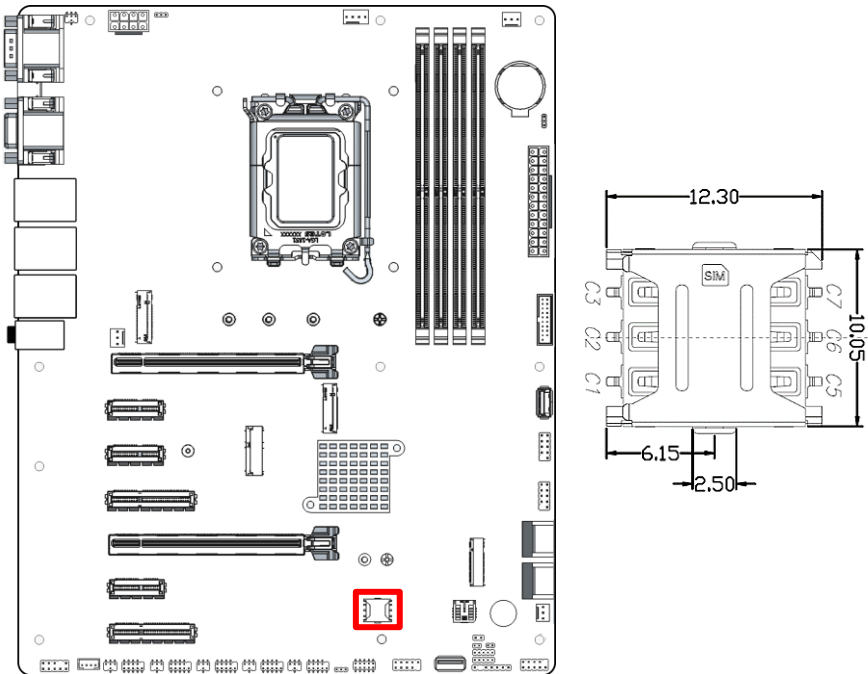

Note: Standard specifications.

2.5.26 M.2 2242/2280/22110 M-Key Slot (M2M1)

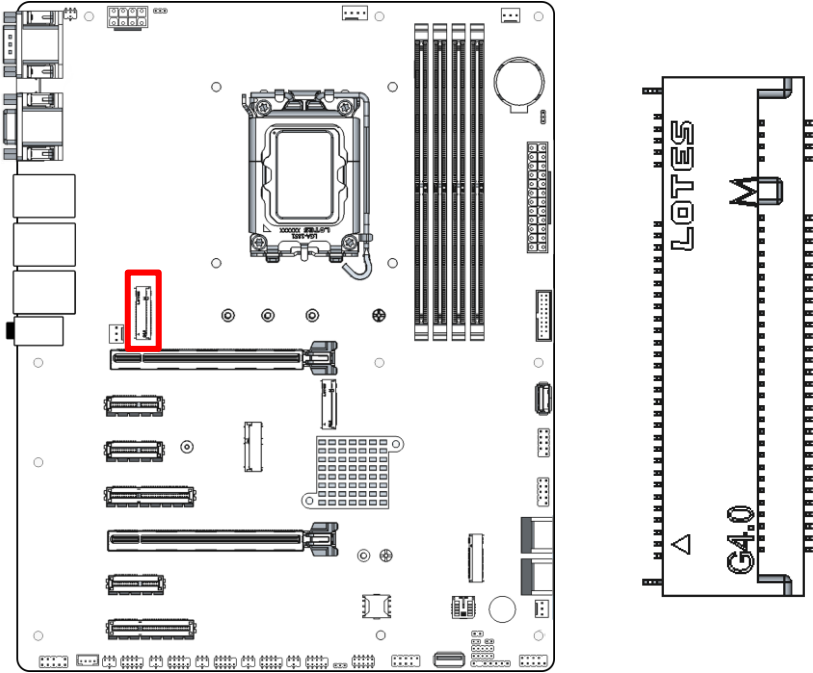

Note: Standard specifications.

2.5.27 M.2 2280 M-Key Slot (M2M2)

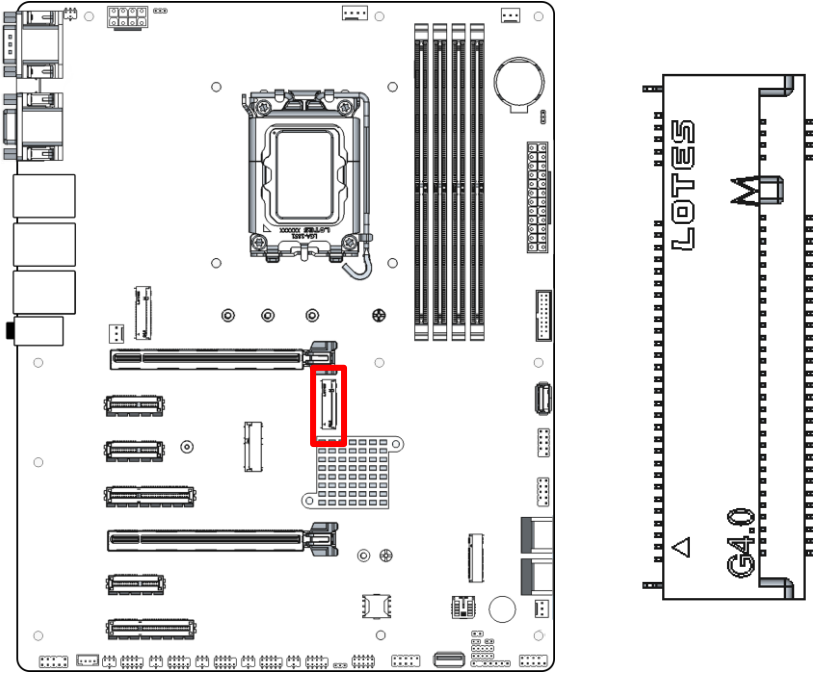

Note: Standard specifications.

2.5.28 M.2 3042/3052 B-Key Slot (M2B1)

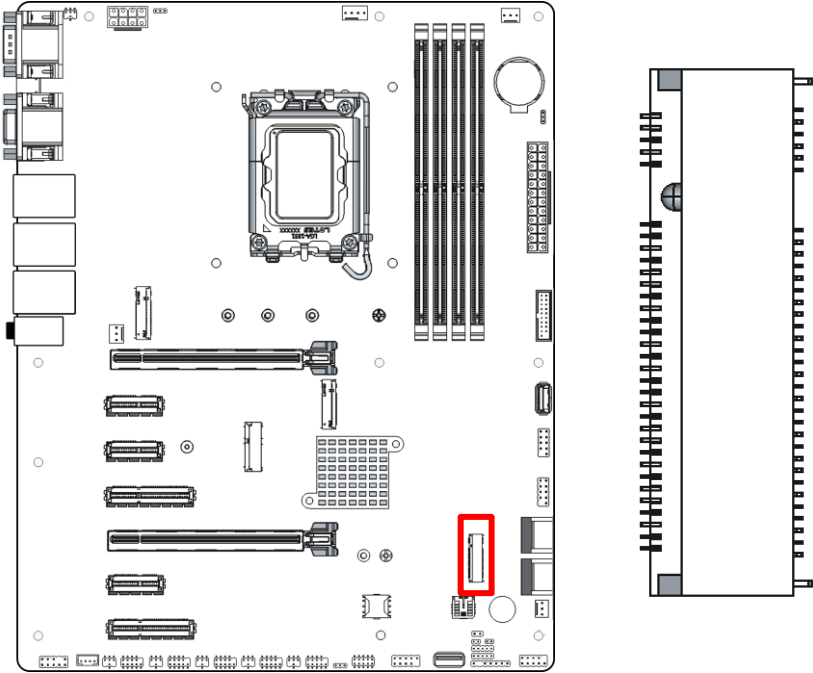

Note: Standard specifications.

2.5.29 M.2 2230 E-Key Slot (M2E1)

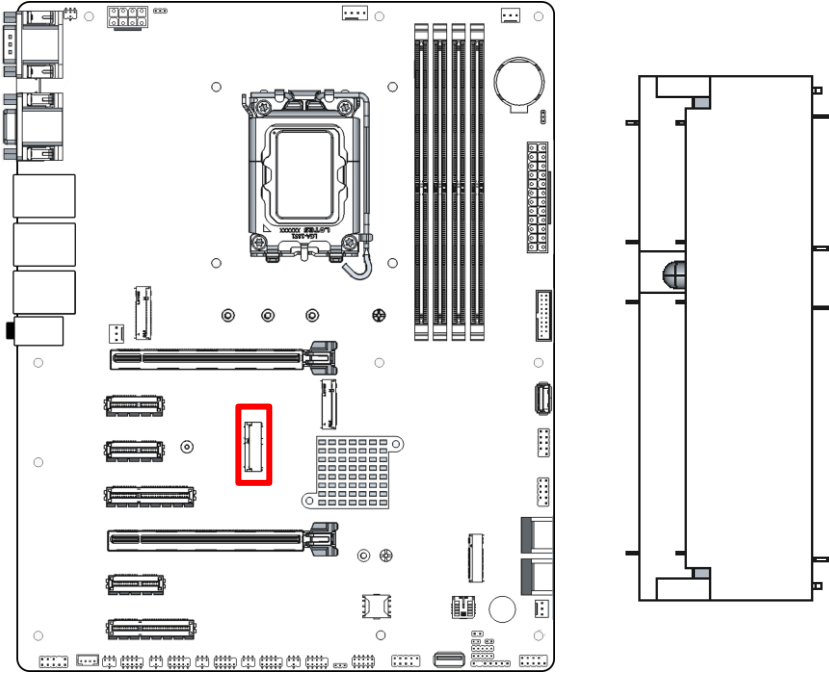

Note: Standard specifications.

2.5.30 DDR5 U-DIMM Sockets (DDR5_A1/A2/B1/B2)

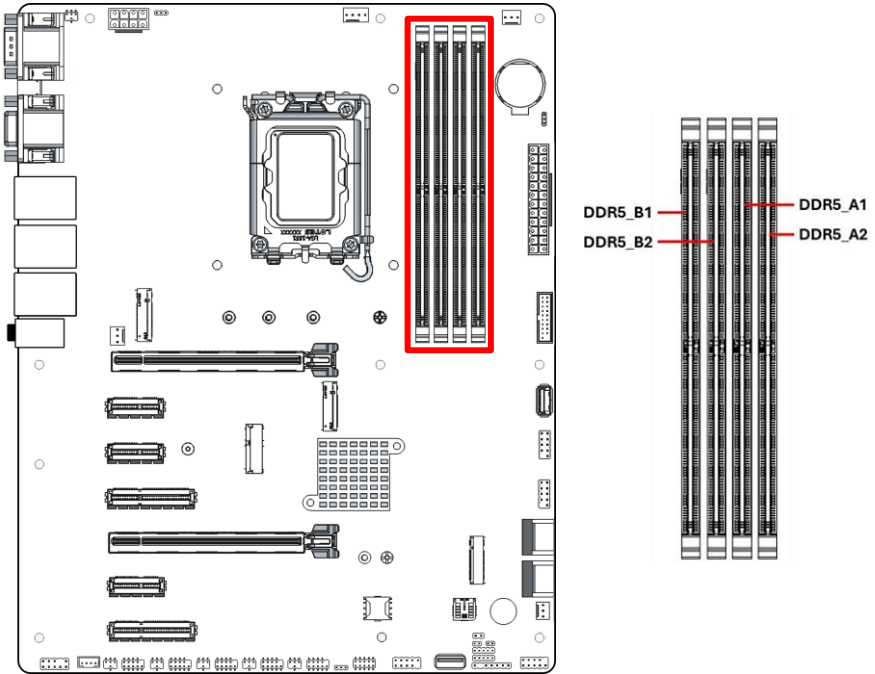

Note:

- Always install memory modules starting with the DDR5_A2 socket.
- Dual-channel operation cannot be enabled when using only one or three memory modules. For dual-channel configuration, modules must be installed in matched pairs, following the right-to-left socket sequence.
- Installing a memory module in the incorrect orientation may cause permanent damage to both the motherboard and the memory module.

Memory module installation recommendation:

Configuration	DDR5_B1	DDR5_B2	DDR5_A1	DDR5_A2
1	--	--	--	install
2	--	install	--	install
4	install	install	install	install

2.5.31 PCIe Gen 5 [x16] Slots (PCIE1/PCIE5)

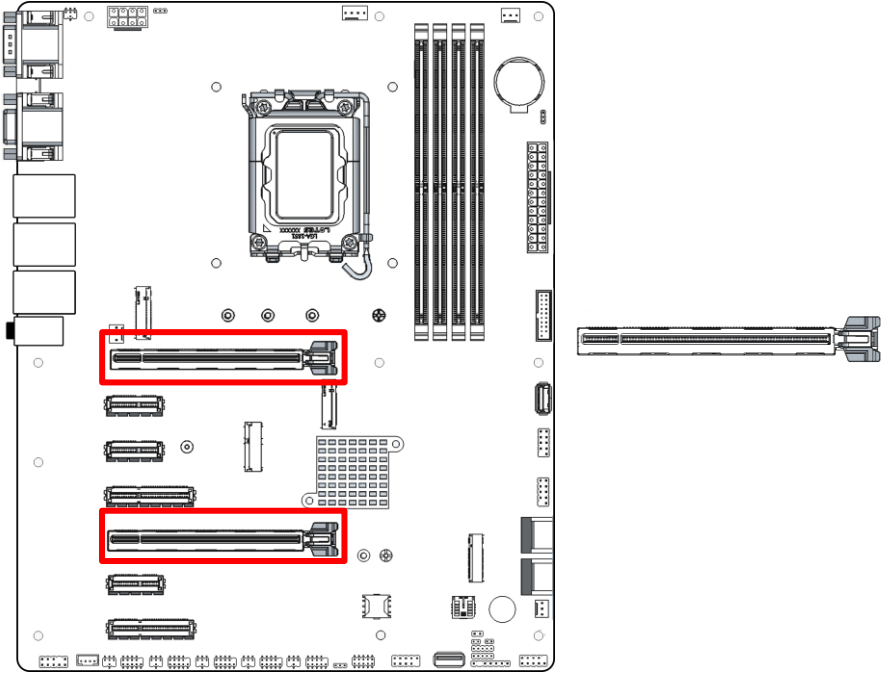

Note: Standard specifications.

2.5.32 PCIe Gen 4 [x1] Slots (PCIE2/PCIE3/PCIE6)

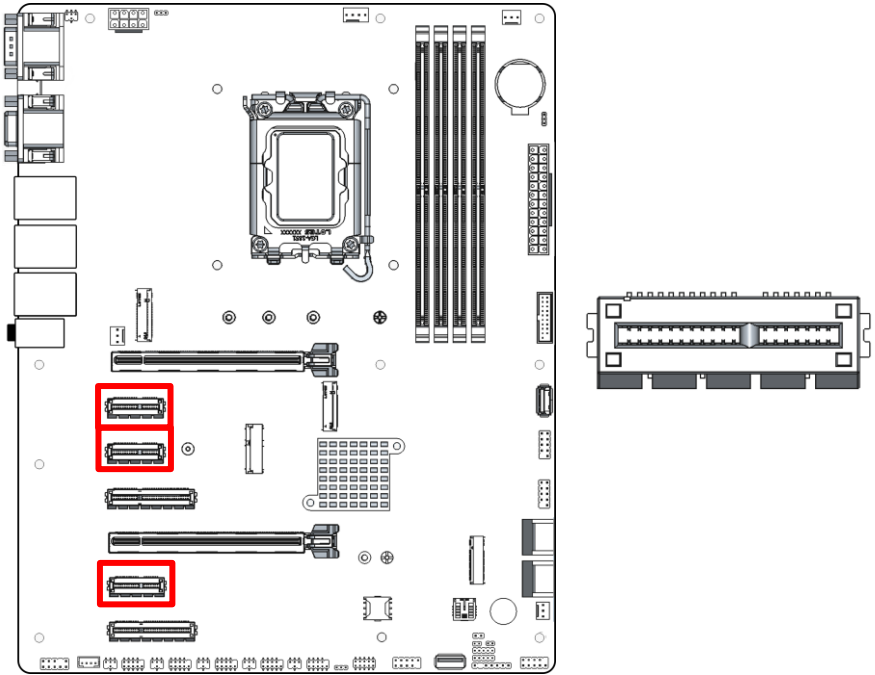

Note: Standard specifications.

2.5.33 PCIe Gen 4 [x4] Slot (PCIE4/PCIE7)

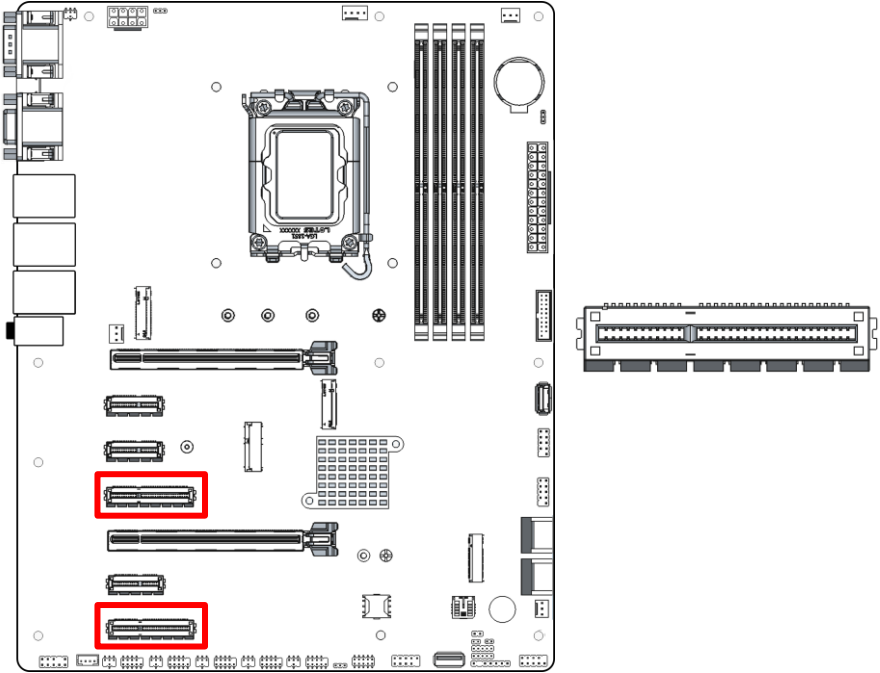

Note: Standard specifications.

2.5.34 Audio Line-In/Line-Out/Mic (AUDIO1)

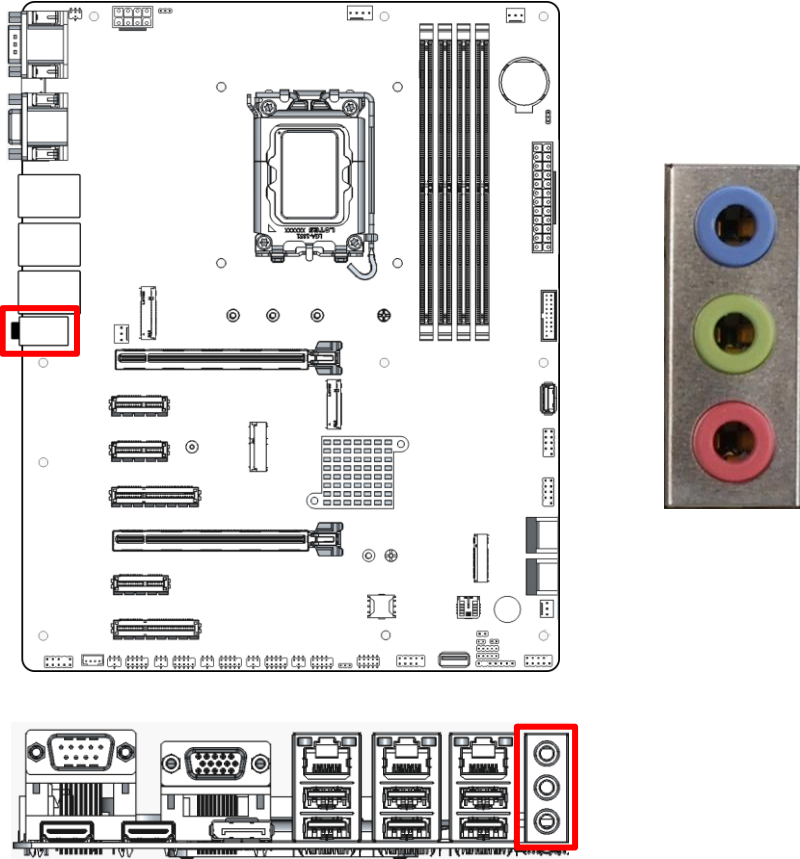

Note: Standard specifications.

2.5.35 24-Pin ATX Power Supply Connector (ATXPWR1)

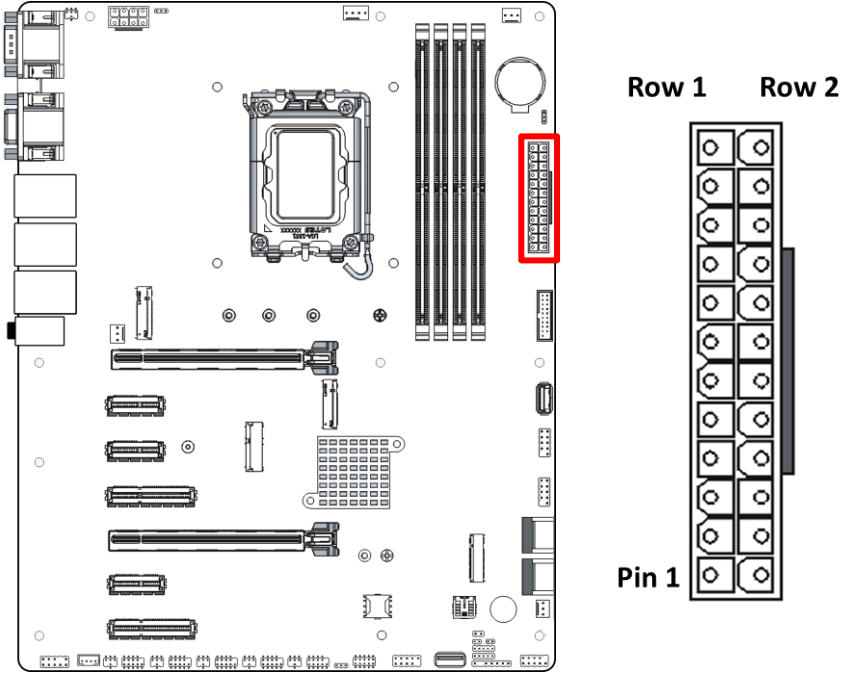

Note: Standard specifications.

2.5.36 8-Pin ATX 12V Power Connector (ATX12V1)

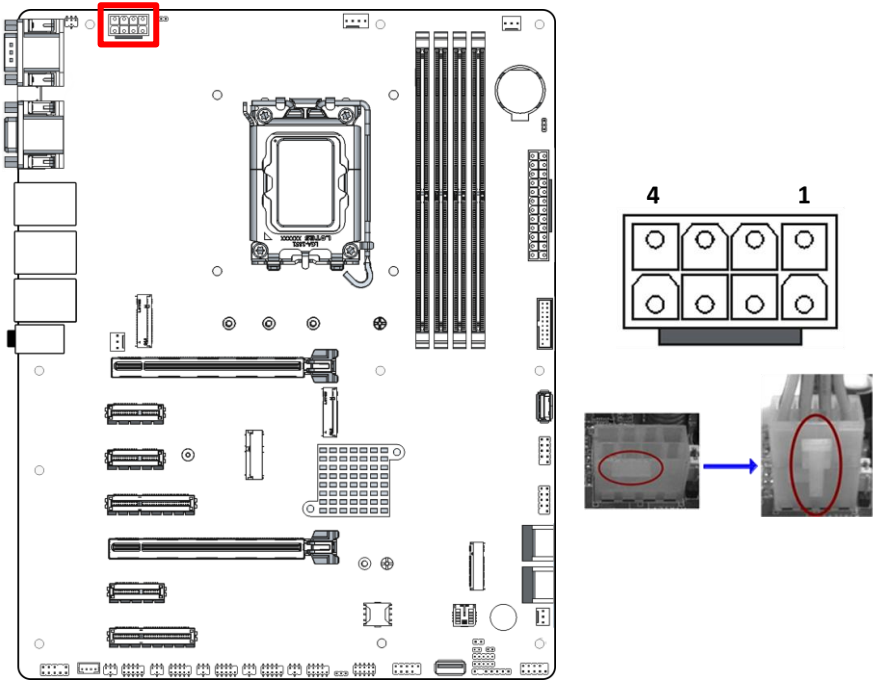

Pin	Signal	Pin	Signal
1	GND	5	+12V
2	GND	6	+12V
3	GND	7	+12V
4	GND	8	+12V

Note: Standard specifications.

Chapter 3

BIOS Setup

3.1 BIOS Setup Program

Use the BIOS Setup program to configure its parameters. The BIOS screens include navigation keys and brief online help to guide you in using the BIOS Setup program.

Power on the computer and press **** immediately to enter the BIOS Setup. If the prompt disappears before you can respond, restart the system and try again by turning the system OFF, then ON, or by pressing the **RESET** button on the chassis. You may also restart the system by pressing **<Ctrl> + <Alt> + <Delete>** simultaneously.

If the keys are not pressed at the correct time and the system fails to boot, an error message will appear and you will be prompted to enter Setup again.



CAUTION! Using the power button, reset button, or the **<Ctrl> + <Alt> + ** keys to reboot a running operating system can cause damage to your data or system. Always shut down the system properly from the operating system.



IMPORTANT:

- The default BIOS settings for this motherboard apply to most working conditions and ensures optimal performance. If the system becomes unstable after changing any BIOS settings, load the default settings to regain system stability. Select the option **Restore Defaults** under the Save & Exit Menu. See section **3.7 Save & Exit**.
 - The BIOS setup screens shown in this section are for reference purposes only, and may not exactly match what you see on your screen.
-

Press to enter Setup; press < F7> to enter pop-up Boot menu

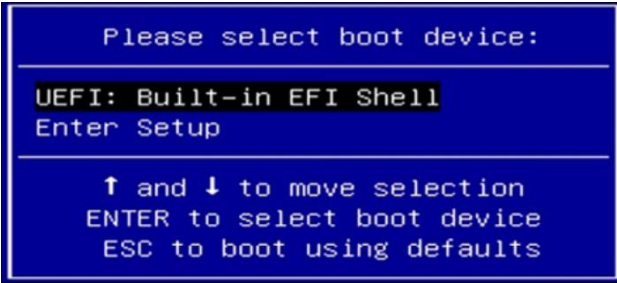

3.2 BIOS Menu Screen

The menu bar on top of the screen has the following main items:

Main - For changing the basic system configuration.

Advanced - For changing the advanced system settings.

Chipset - For viewing and changing chipset settings.

Security - For setting up BIOS security settings.

Boot - For changing the system boot configuration.

Save & Exit - For selecting the exit options and loading default settings.

To select an item on the menu bar, press the right or left arrow key on the keyboard until the desired item is highlighted.

The Main menu provides you an overview of the basic system information, and allows you to set the system date, time, language, and security settings.

System Date [Day MM/DD/YYYY]: Allows you to set the system date.

System Time [HH:MM:SS]: Allows you to set the system time.

3.3 Setup Submenu: Main Menu

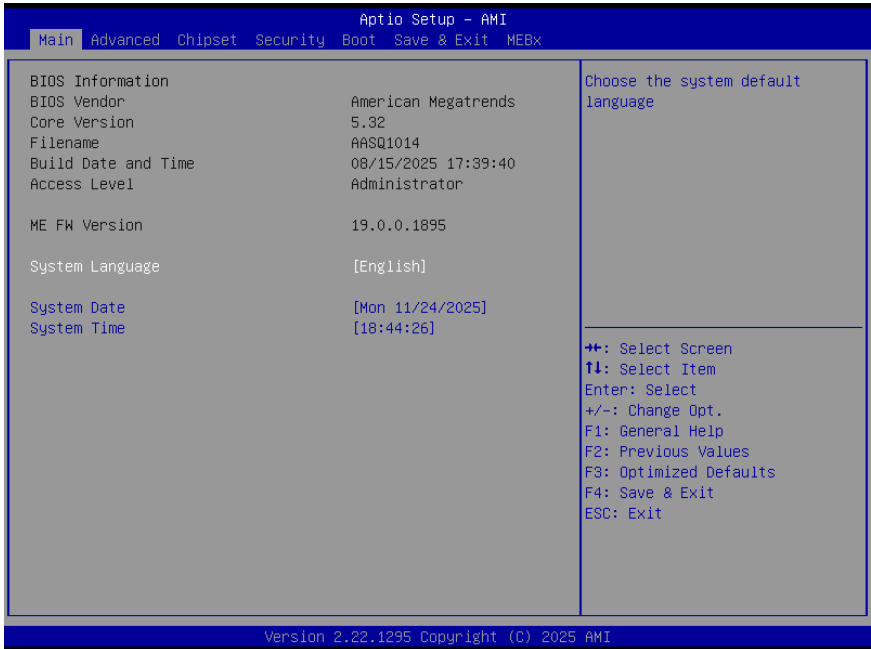

3.4 Setup Submenu: Advanced

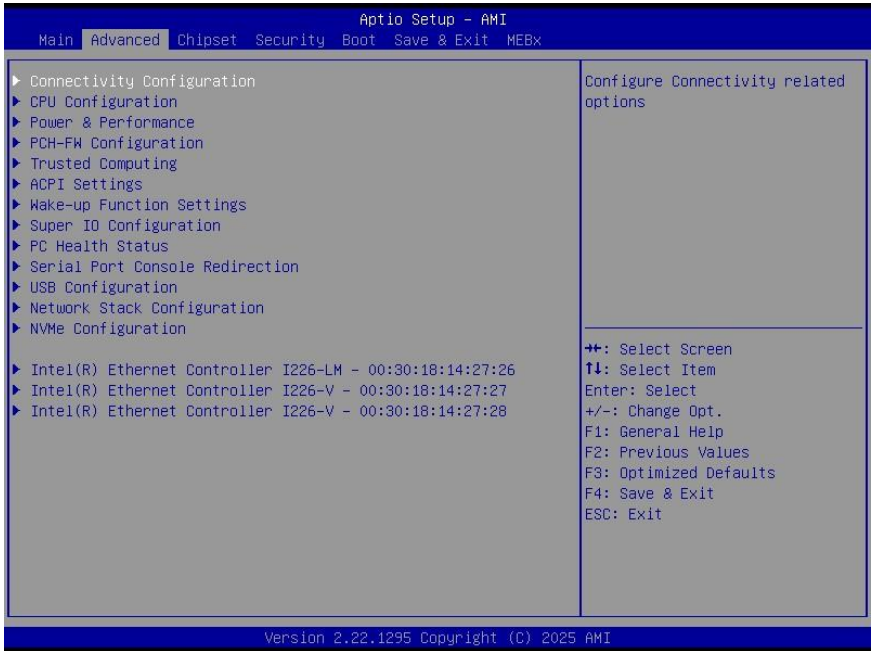

The Advanced menu items allow you to change the settings for the CPU and other system devices.



CAUTION! Be cautious when changing the settings of the Advanced menu items. Incorrect field values can cause the system to malfunction.

3.4.1 CNVi Mode Detection



Options Summary	
CNVi Mode	Auto Detection
	Disabled Integrated
Auto Detection: If a discrete wireless solution is detected, it will be enabled by default. Otherwise, the integrated CNVi solution will be enabled.	
Disabled Integrated: Disables the integrated CNVi solution.	

3.4.2 CPU Configuration



The items in this menu show CPU-related information the BIOS automatically detects.



Important: The items shown in the submenu may be different depending on the type of CPU installed.

Efficient-core Information

Aptio Setup - AMI

Advanced

Efficient-core Information

L1 Data Cache	384 KB
L1 Instruction Cache	768 KB
L2 Cache	12288 KB
L3 Cache	30 MB

⇧⇧: Select Screen
⇧⇧: Select Item
Enter: Select
+/-: Change Opt.
F1: General Help
F2: Previous Values
F3: Optimized Defaults
F4: Save & Exit
ESC: Exit

Version 2.22.1295 Copyright (C) 2025 AMI

Performance-core Information

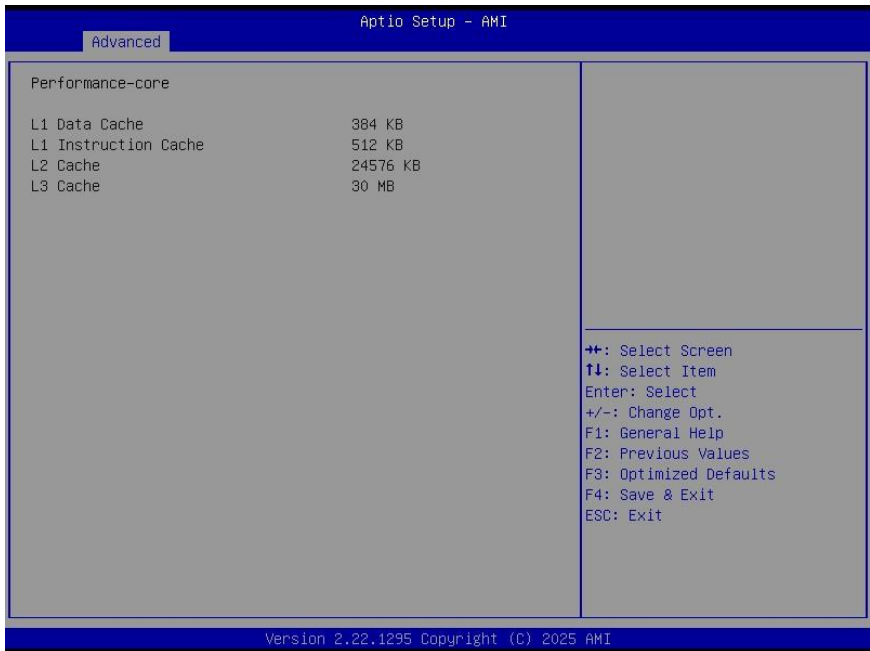

Options Summary	
Boot Performance Mode	Min Non-Turbo Performance
	Max Non-Turbo Performance
	Turbo Performance
Selects the performance state that the BIOS will apply starting from the reset vector.	
Intel® SpeedStep™	Enabled
	Disabled
Enables support for more than two CPU frequency ranges, allowing dynamic adjustment of processor speed.	
Turbo Mode	Enabled
	Disabled
This item allows you to automatically set the CPU cores to run faster than the base operating frequency when it is below the operating power, current and temperature specification limit.	
C States	Enabled
	Disabled
Enables or disables CPU power management. When enabled, the CPU may enter C states when not 100% utilized.	

3.4.3 Power & Performance



3.4.3.1 CPU – Power Management Control

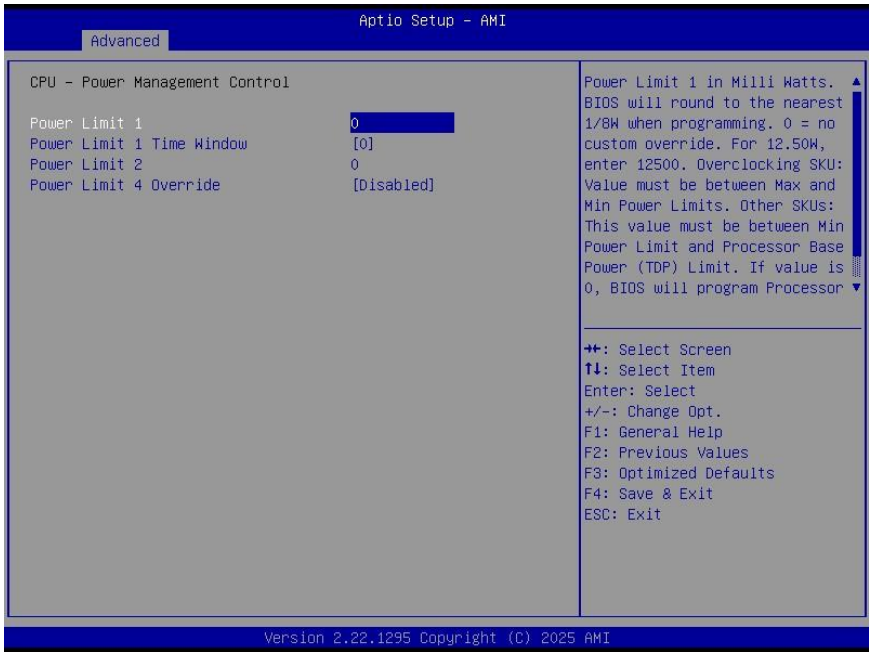

Options Summary

Power Limit 1 | 0

Sets Power Limit 1 in milliWatts. The BIOS rounds to the nearest 1/8 W when programming.

0: No custom override; BIOS will use the Processor Base Power (TDP) value.

Overclocking SKUs: Value must be between the Max and Min Power Limits (PACKAGE_POWER_SKU_MSR).

Other SKUs: Value must be between Min Power Limit and Processor Base Power (TDP). For example, enter 12500 for 12.50 W.

Options Summary	
Power Limit 1 Time Window	0
	1
	2
	3
	4
	5
	6
	7
	8
	9
	10
	12
	14
	16
	20
	24
	28
	32
	40
	48
56	
64	
80	
96	
112	
128	
Sets the Power Limit 1 time window in seconds. Defines the duration for which the Processor Base Power (TDP) should be maintained.	
Power Limit 2	0
Sets Power Limit 2 in milliwatts. BIOS rounds to the nearest 1/8 W when programming.	
0: No custom override. Processor applies control policies so that package power does not exceed this limit.	
For example, enter 12500 for 12.50 W.	
Power Limit 4 Override	Disabled
	Enabled
Enables or disables BIOS override for Power Limit 4.	
Disabled: BIOS leaves default values.	
Enabled: Allows custom Power Limit 4 value.	

Options Summary	
Power Limit 4	0
Sets Power Limit 4 in milliWatts. BIOS rounds to the nearest 1/8 W when programming.	
0: No custom override. Processor applies control policies so that package power does not exceed this limit.	
For example, enter 12500 for 12.50 W.	

3.4.3.2 GT/Media-Power Management Control

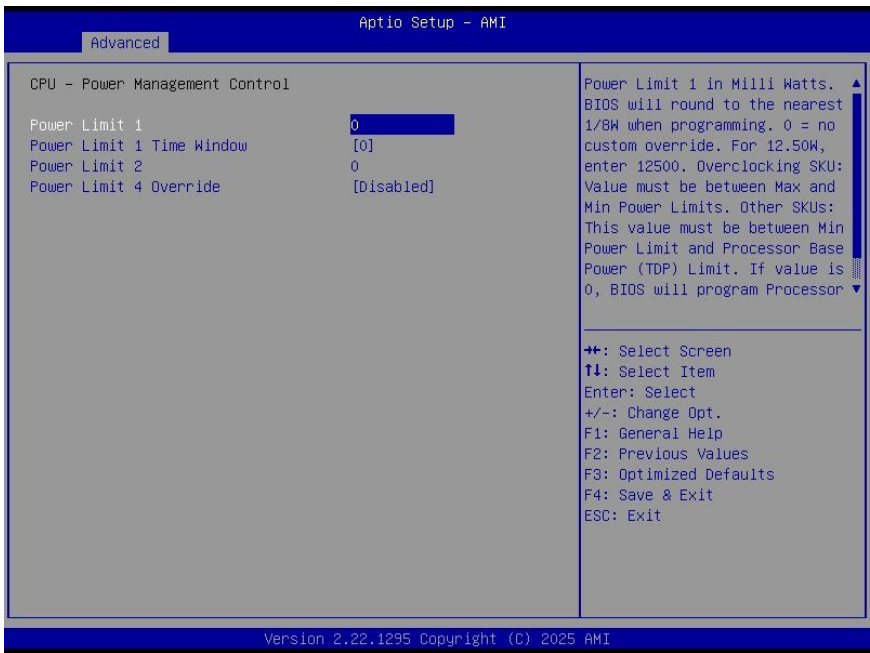

Options Summary	
RC6(Render Standby)	Enabled
	Disabled
Enables or disables render standby support for the GPU.	
RC6(Media Standby)	Enabled
	Disabled
Enables or disables media standby support for the GPU.	

Options Summary

Maximum GT frequency

100Mhz

150Mhz

200Mhz

250Mhz

300Mhz

350Mhz

400Mhz

450Mhz

500Mhz

550Mhz

600Mhz

650Mhz

700Mhz

750Mhz

800Mhz

850Mhz

900Mhz

950Mhz

1000Mhz

1050Mhz

1100Mhz

1150Mhz

1200Mhz

Sets the maximum GT frequency limited by the user.

The range is 100 MHz (RPN) to 1200 MHz (RP0).

Values beyond the supported range will be clipped to the minimum or maximum supported by the SKU.

Disable Turbo GT Frequency

Disabled

Enabled

Enables or disables turbo GT frequency.

Disabled: GT frequency is not limited.

Enabled: Turbo GT frequency is disabled, limiting maximum GPU frequency.

3.4.4 PCH-FW Configuration



Options Summary	
TPM Device Selection	PTT
	dTPM
[PTT]: Enables PTT in SkuMgr., [dTPM]: Disables PTT in SkuMgr.	

3.4.5 Trusted Computing

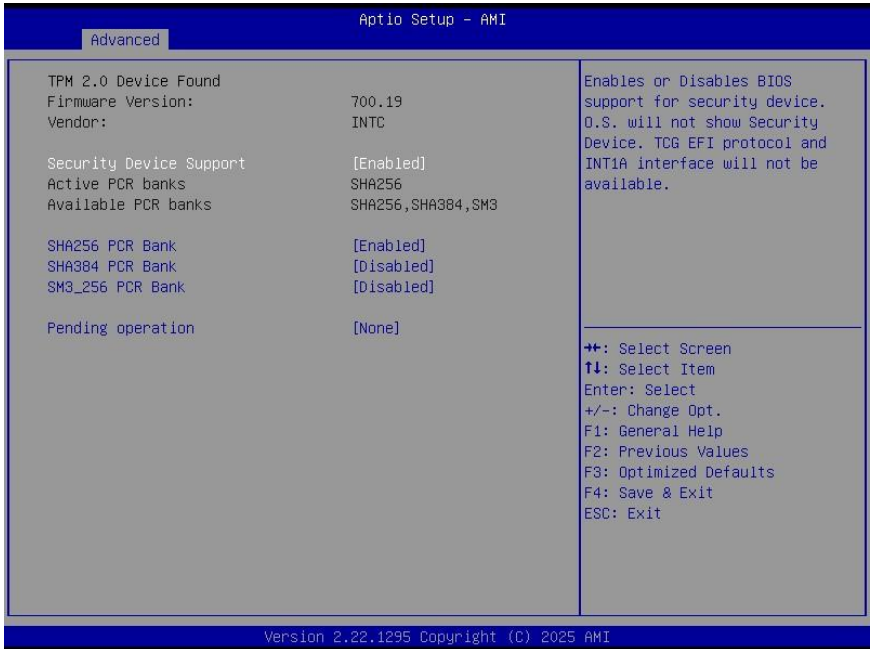

Options Summary	
Security Device Support	Enabled
	Disabled
Allows you to enable or disable BIOS support for security devices.	
SHA256 PCR Bank	Enabled
	Disabled
Enables or disables the SHA256 PCR bank.	
SHA384 PCR Bank	Enabled
	Disabled
Allows you to enable or disable SHA384 PCR Bank.	
SM3_256 PCR Bank	Enabled
	Disabled
Allows you to enable or disable SM3_256 PCR Bank.	
Pending operation	None
	TPM Clear
Schedule an Operation for the Security Device.	
Note: Your Computer will reboot during restart in order to change State of Security Device.	

3.4.6 ACPI Settings

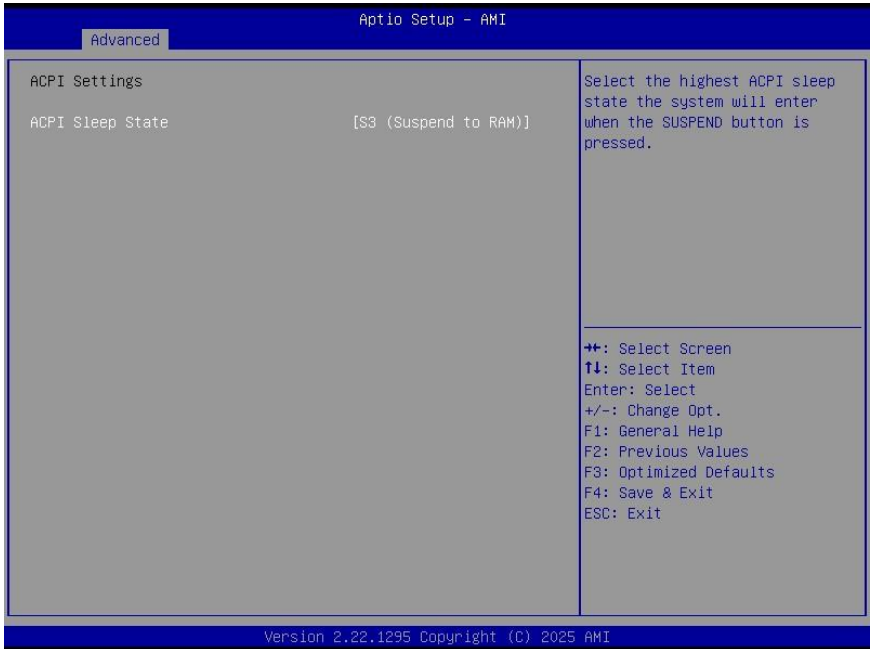

Options Summary	
ACPI Sleep State	Suspend Disabled
	S3 (Suspend to RAM)
Selects the highest ACPI sleep state the system will enter when the suspend button is pressed.	

3.4.7 Wake-up Function Settings

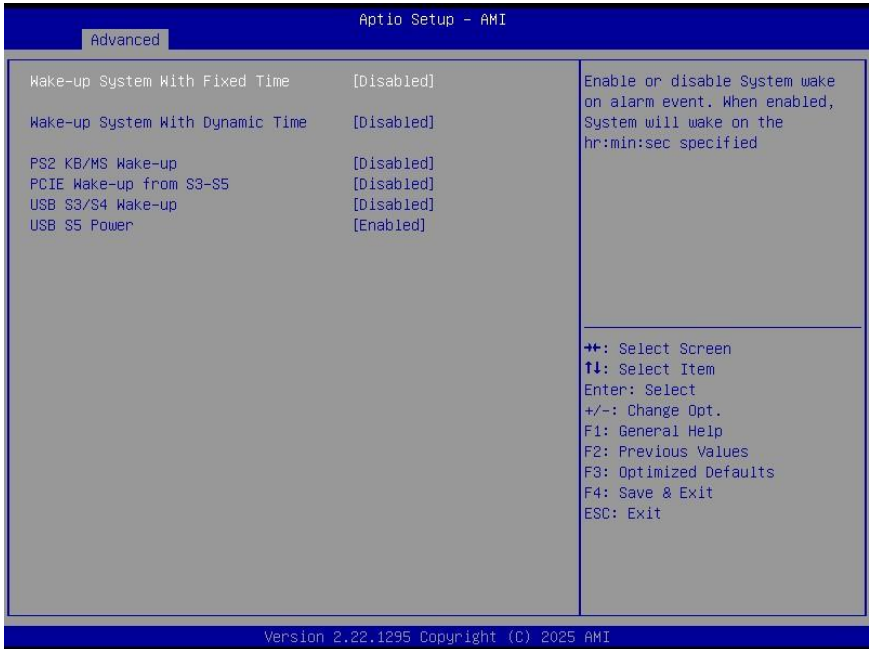

Options Summary	
Wake-up System With Fixed Time	Disabled
	Enabled
<p>Enables or disables system wake-up using an RTC alarm. This option appears only when Wake-up System with Dynamic Time is set to Disabled. When Enabled, the following settings become available:</p> <p>Wake-up Hour</p> <ul style="list-style-type: none"> Range: 0–23 Optimal Default, Failsafe Default: 0 Description: Sets the hour for system wake-up (e.g., 3 = 3 AM, 15 = 3 PM). <p>Wake-up Minute</p> <ul style="list-style-type: none"> Range: 0–59 Optimal Default, Failsafe Default: 0 Description: Sets the minute for system wake-up. <p>Wake-up Second</p> <ul style="list-style-type: none"> Range: 0–59 Optimal Default, Failsafe Default: 0 Description: Sets the second for system wake-up. 	
Wake-up System with Dynamic Time	Disabled
	Enabled

Options Summary

Enables or disables system wake-up using a dynamic RTC alarm. This option appears only when **Wake-up System With Fixed Time** is set to **Disabled**.

- When **Enabled**, the following setting becomes available:

Wake-up Minute Increase

- Range: 1–60 Optimal Default, Failsafe Default: 1

Description: Sets the number of minutes to add to the current time for system wake-up.

PS2 KB/MS Wake-Up

Disabled

Enabled

Enables or disables system wake-up via PS/2 keyboard or mouse from S3/S4/S5 states.

Note: Requires ERP to be disabled for S4/S5 wake-up.

PCIe Wake-up from S3-S5

Disabled

Enabled

Enables or disables system wake-up via PCIe devices from S3, S4, or S5 states.

USB S3/S4 Wake-up

Disabled

Enabled

Enables or disables USB wake-up from S3 or S4 states.

Note: ERP must be disabled for proper functionality.

USB S5 Power

Enabled

Disabled

Enables or disables USB power after system shutdown (S5).

Note: ERP must be disabled for proper functionality.

3.4.8 Super IO Configuration

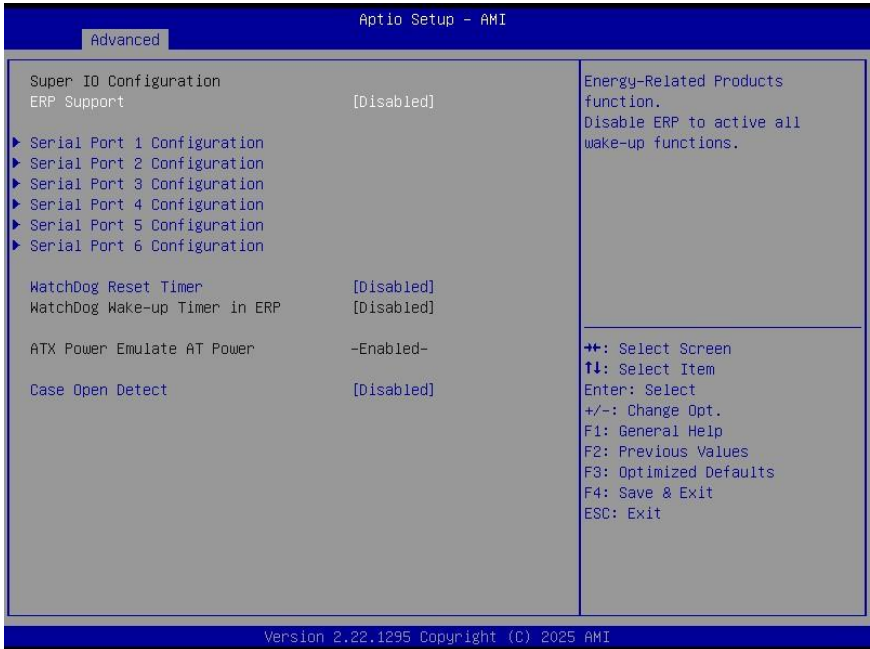

Options Summary	
ERP Support	Disabled
	Enabled
Enables ERP (Energy-Related Products) support.	
Disabled: All wake-up functions are active.	
Enabled: ERP energy-saving mode is active, which may disable some wake-up functions.	

3.4.8.1 Serial Port 1 Configuration

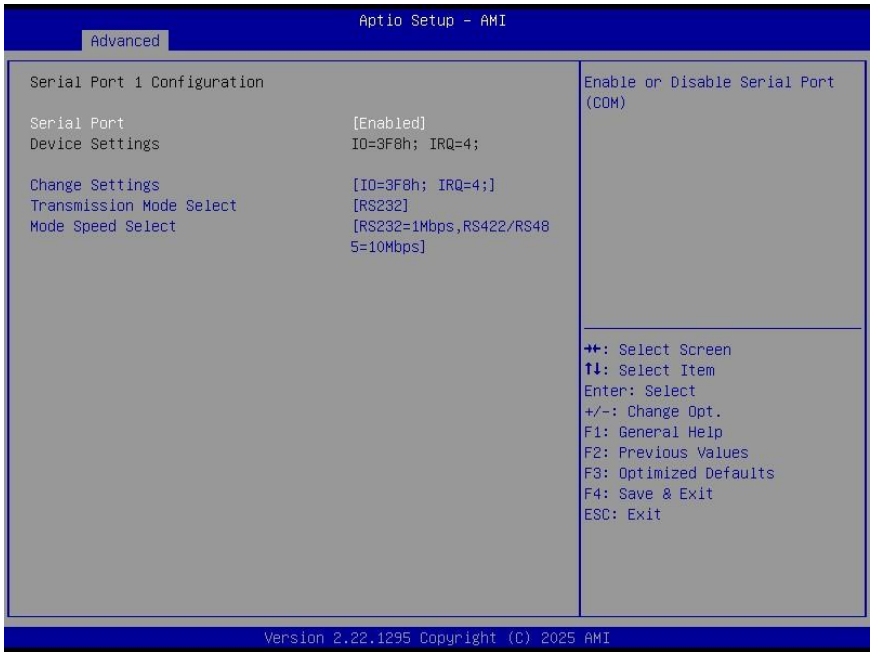

Options Summary	
Serial Port	Enabled Disabled
Enables or disables Serial Port 1.	
Device Settings	IO=3F8h; IRQ=4 IO=2F8h; IRQ=3,4,5,7,10,11 IO=3E8h; IRQ=3,4,5,7,10,11 IO=2E8h; IRQ=3,4,5,7,10,11
Selects I/O address and IRQ for COM1.	
Transmission Mode Select	RS232 RS422 RS485
UART RS232, 422, 485 selection.	
Mode Speed Select	RS232/RS422/RS485 = 250 Kbps RS232=1Mbps, RS422/RS485=10Mbps
Sets the speed for the selected UART transmission mode.	

3.4.8.2 Serial Port 2 Configuration

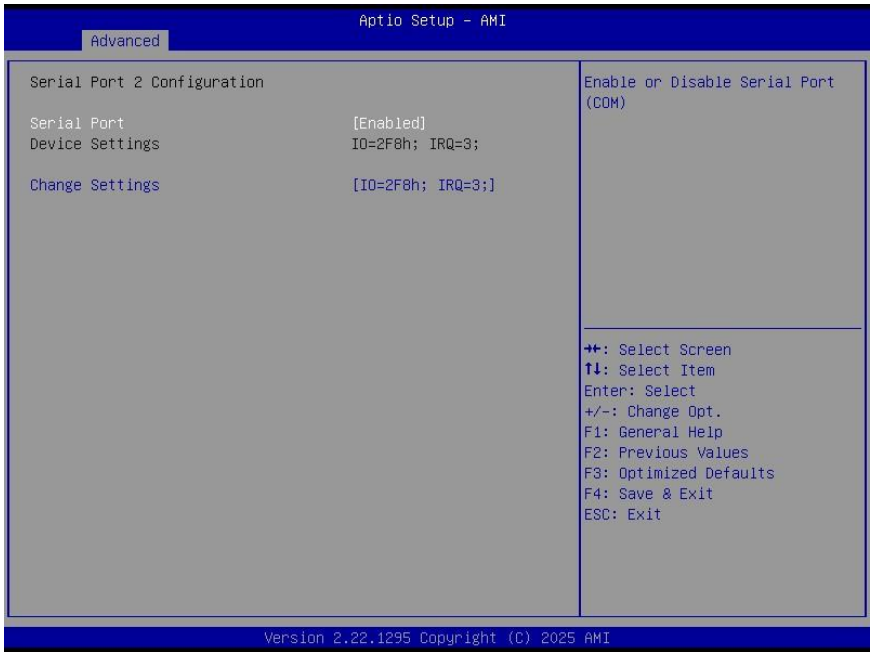

Options Summary	
Serial Port	Enabled
	Disabled
Enables or disables Serial Port 2.	
Device Settings	IO=2F8h; IRQ=3
	IO=3F8h; IRQ=3,4,5,7,10,11
	IO=2F8h; IRQ=3,4,5,7,10,11
	IO=3E8h; IRQ=3,4,5,7,10,11
	IO=2E8h; IRQ=3,4,5,7,10,11
Selects I/O address and IRQ for COM2.	

3.4.8.3 Serial Port 3 Configuration

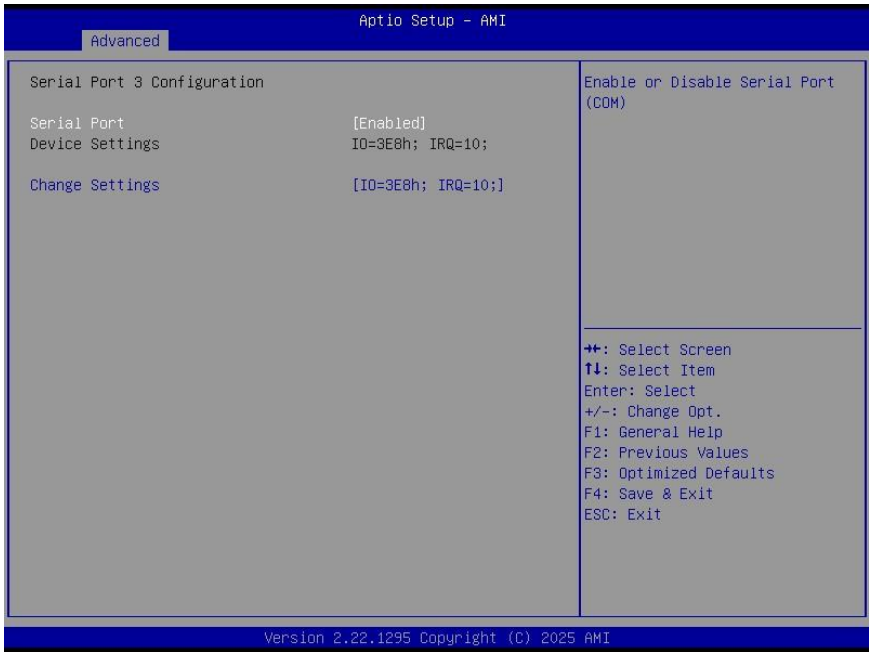

Options Summary	
Serial Port	Enabled
	Disabled
Enables or disables Serial Port 3.	
Device Settings	IO=3F8h; IRQ=10
	IO=3F8h; IRQ=3,4,5,7,10,11
	IO=2F8h; IRQ=3,4,5,7,10,11
	IO=3E8h; IRQ=3,4,5,7,10,11
	IO=2E8h; IRQ=3,4,5,7,10,11
	IO=3E0h; IRQ=3,4,5,7,10,11
	IO=2E0h; IRQ=3,4,5,7,10,11
Selects I/O address and IRQ for COM3.	

3.4.8.4 Serial Port 4 Configuration

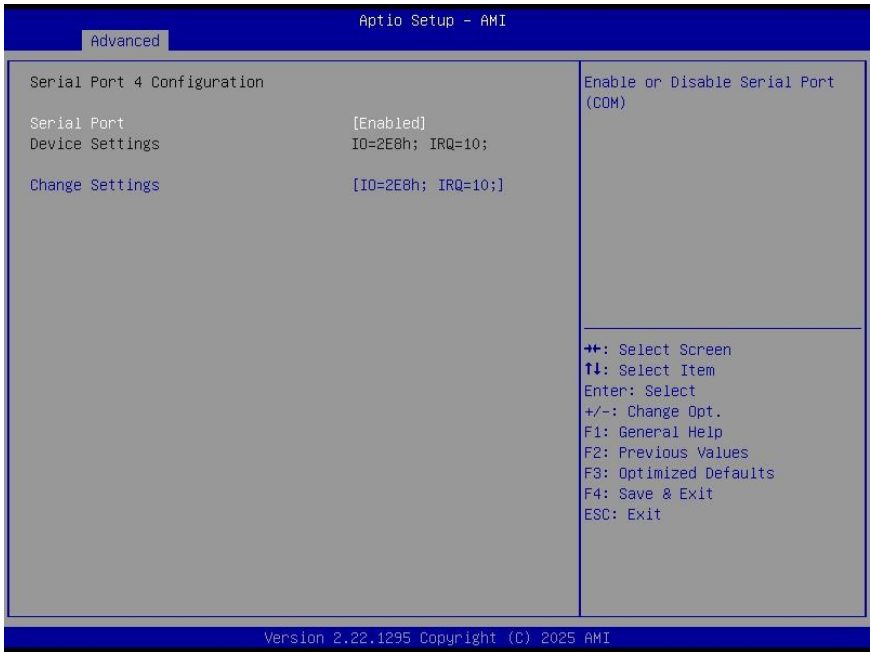

Options Summary	
Serial Port	Enabled
	Disabled
Enables or disables Serial Port 4.	
Device Settings	IO=2E8h; IRQ=10
	IO=3F8h; IRQ=3,4,5,7,10,11
	IO=2F8h; IRQ=3,4,5,7,10,11
	IO=3E8h; IRQ=3,4,5,7,10,11
	IO=2E8h; IRQ=3,4,5,7,10,11
	IO=3E0h; IRQ=3,4,5,7,10,11
	IO=2E0h; IRQ=3,4,5,7,10,11
Selects I/O address and IRQ for COM4.	

3.4.8.5 Serial Port 5 Configuration

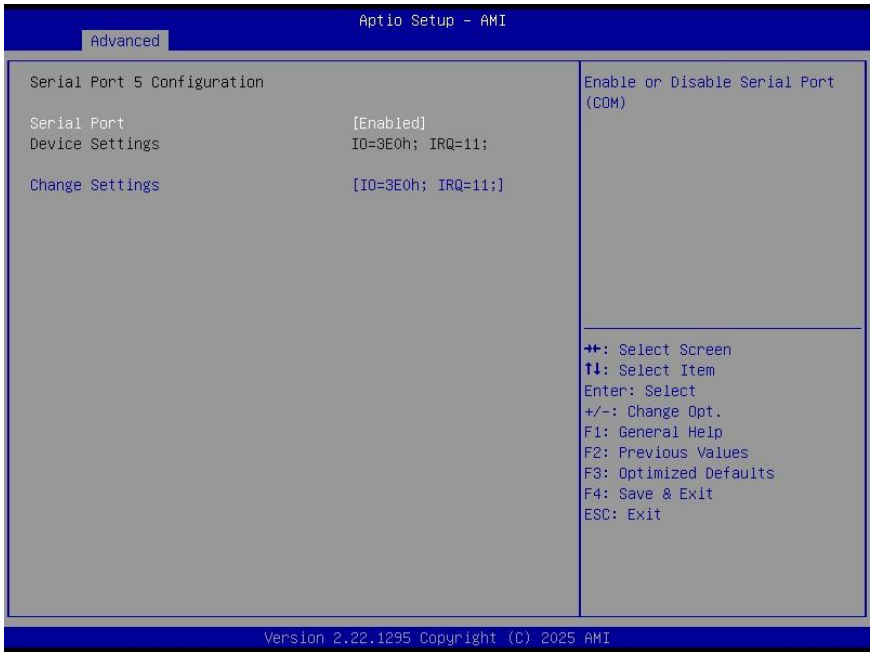

Options Summary	
Serial Port	Enabled
	Disabled
Enables or disables Serial Port 6.	
Device Settings	IO=3E0h; IRQ=11
	IO=3F8h; IRQ=3,4,5,7,10,11
	IO=2F8h; IRQ=3,4,5,7,10,11
	IO=3E8h; IRQ=3,4,5,7,10,11
	IO=2E8h; IRQ=3,4,5,7,10,11
	IO=3E0h; IRQ=3,4,5,7,10,11
	IO=2E0h; IRQ=3,4,5,7,10,11
Selects I/O address and IRQ for COM6.	

3.4.8.6 Serial Port 6 Configuration

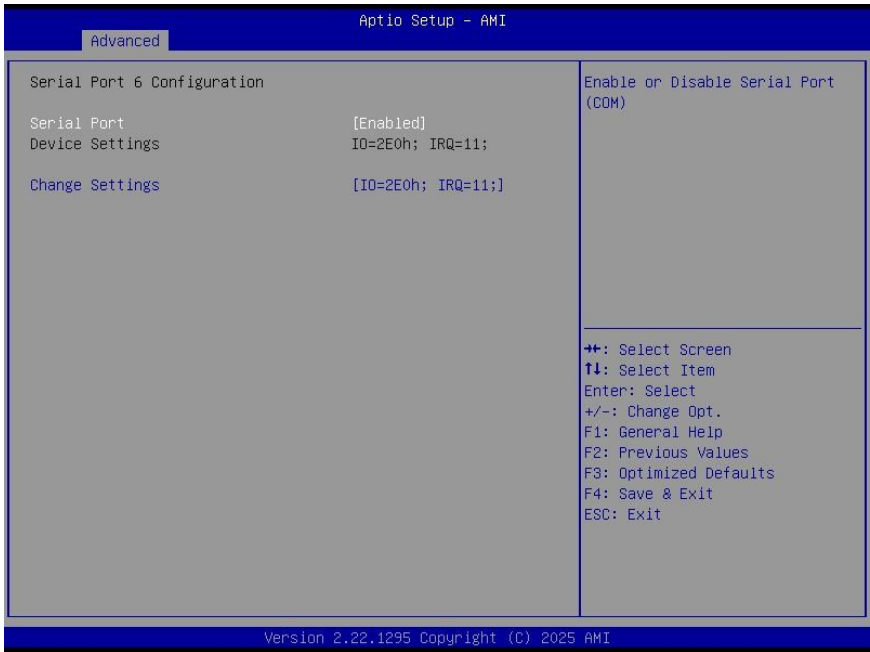

Options Summary	
Serial Port	Enabled
	Disabled
Enables or disables Serial Port 5.	
Device Settings	IO=2E0h; IRQ=11
	IO=3F8h; IRQ=3,4,5,7,10,11
	IO=2F8h; IRQ=3,4,5,7,10,11
	IO=3E8h; IRQ=3,4,5,7,10,11
	IO=3E8h; IRQ=3,4,5,7,10,11
	IO=2E8h; IRQ=3,4,5,7,10,11
	IO=3E0h; IRQ=3,4,5,7,10,11
	IO=2E0h; IRQ=3,4,5,7,10,11
Selects I/O address and IRQ for COM5.	

3.4.9 PC Health Status

The screenshot shows the 'Advanced' tab of the 'Aptio Setup - AMI' BIOS. The 'PC Health Status' section is expanded to show 'SmartFAN Configuration'. The configuration table lists various system metrics and their current values. A legend on the right side of the screen explains the navigation keys used in the BIOS.

Item	Value
CPU Temperature	: +39 C
System Temperature	: +29 C
CPUFAN Speed	: 2495 RPM
SYSFAN1 Speed	: 0 RPM
SYSFAN2 Speed	: 0 RPM
VCCORE	: +0.968 V
VCC	: +4.972 V
+12V	: +12.144 V
VDIMM	: +1.105 V
VCC3V	: +3.328 V
VSB3V	: +3.312 V
VBAT	: +3.056 V

Legend:

- ⇐⇐: Select Screen
- ⇐⇐: Select Item
- Enter: Select
- +/-: Change Opt.
- F1: General Help
- F2: Previous Values
- F3: Optimized Defaults
- F4: Save & Exit
- ESC: Exit

Version 2.22.1295 Copyright (C) 2025 AMI

3.4.10 Smart Fan Configuration

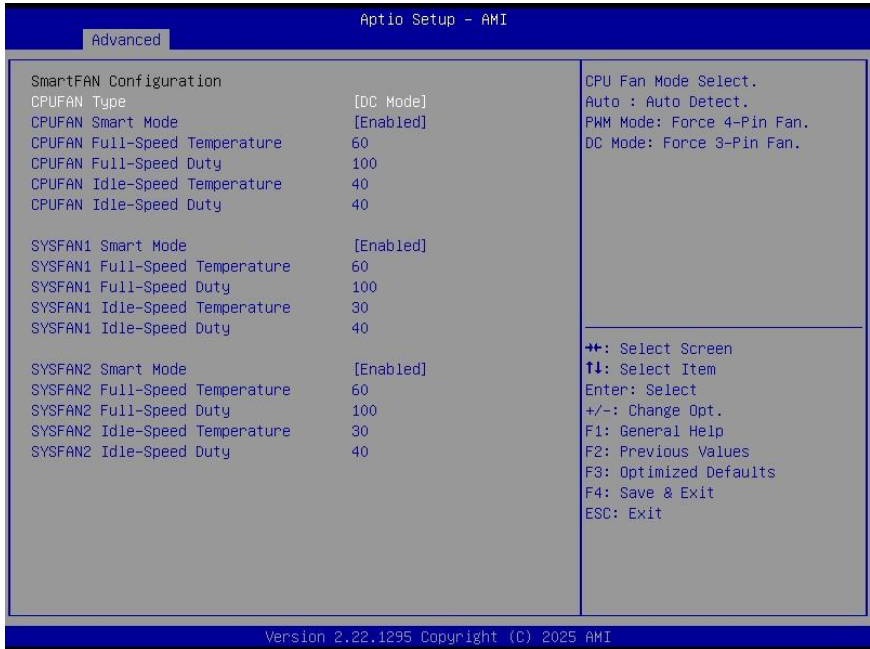

Options Summary	
CPUFAN Type	PWM Mode
	DC Mode
Selects CPU fan mode.	
PWM Mode: Forces 4-pin fan operation.	
DC Mode: Forces 3-pin fan operation.	
CPUFAN1 Smart Mode	Disabled
	Enabled
CPUFAN Full-Speed Temperature	60
CPUFAN Full-Speed Duty	100
Fan will run at full speed when above this pre-set duty.	
CPUFAN Idle-Speed Temperature	40
Fan will run at idle speed when below this pre-set temperature.	
CPUFAN Idle-Speed Duty	40
Fan will run at idle speed when below this pre-set duty.	
SYSFAN1 Smart Mode / SYSFAN2 Smart Mode	Disabled
	Enabled

Options Summary	
SYSFAN1/SYSFAN2 Full-Speed Temperature	60
SYSFAN1/SYSFAN2 Full-Speed Duty	100
Fan will run at full speed when above this pre-set duty.	
CPUFAN Idle-Speed Temperature	30
Fan will run at idle speed when below this pre-set temperature.	
CPUFAN Idle-Speed Duty	40
Fan will run at idle speed when below this pre-set duty.	

3.4.11 Serial Port Console Redirection

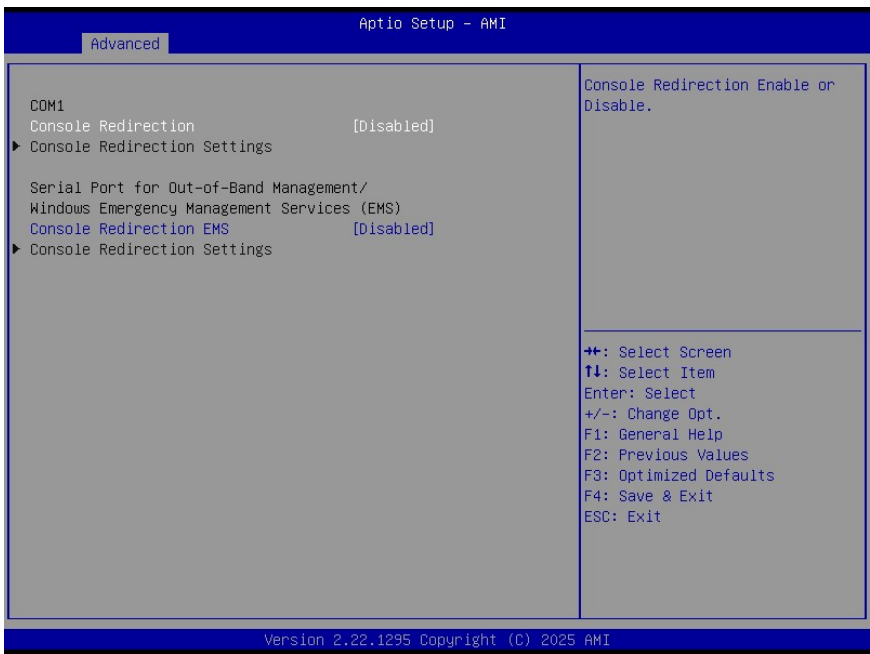

Options Summary	
Console Redirection	Disabled
	Enabled
Enable or Disable Console Redirection. When set to Enabled, additional configuration options become available in the Console Redirection Settings screen.	

3.4.11.1 Console Redirection EMS

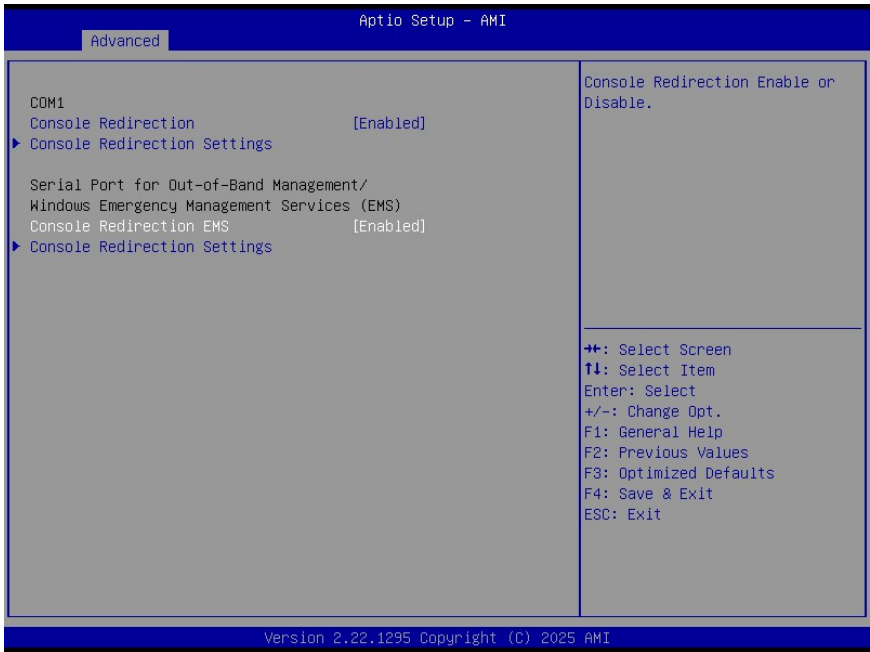

Options Summary	
Console Redirection EMS	Disabled
	Enabled
Enable or Disable Console Redirection EMS. When set to Enabled, additional configuration options become available in the Console Redirection Settings screen.	

3.4.11.2 Console Redirection Settings (Out-of-Band Mgmt Port)

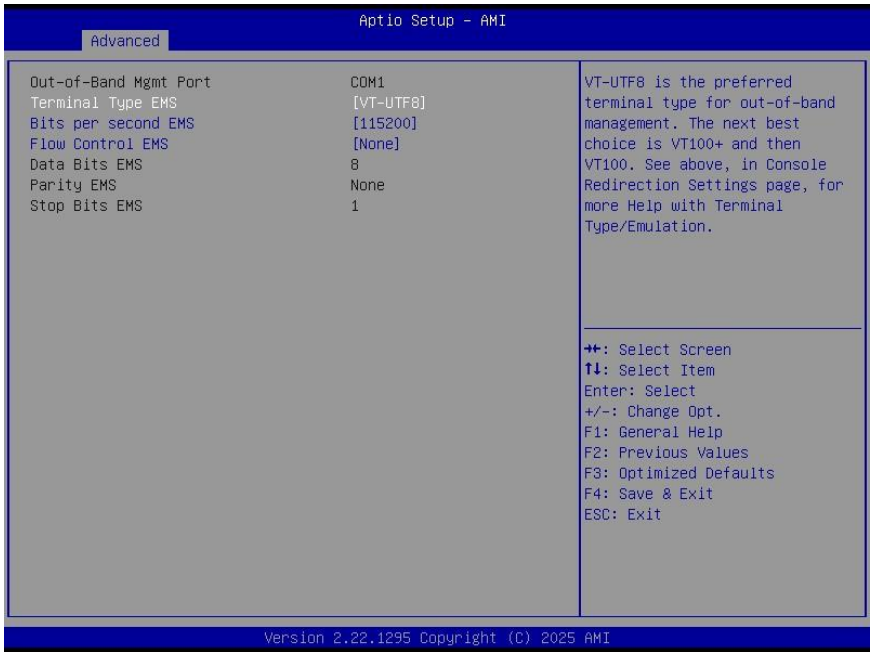

Options Summary	
Terminal Type EMS	VT100
	VT100Plus
	VT-UTF8
	ANSI
Specifies the terminal emulation type used for data exchange between the host computer and the remote system. Both systems must use the same or compatible settings.	
Bits per second EMS	9600
	19200
	38400
	57600
	115200
	230400
	460800
921600	
Use this item to select serial port transmission speed. The speed must be matched on	

Options Summary	
the other side. Long or noisy lines may require lower speeds.	
Data Bits EMS	8
Parity EMS	None
Stop Bits EMS	1

3.4.12 Console Redirection Settings

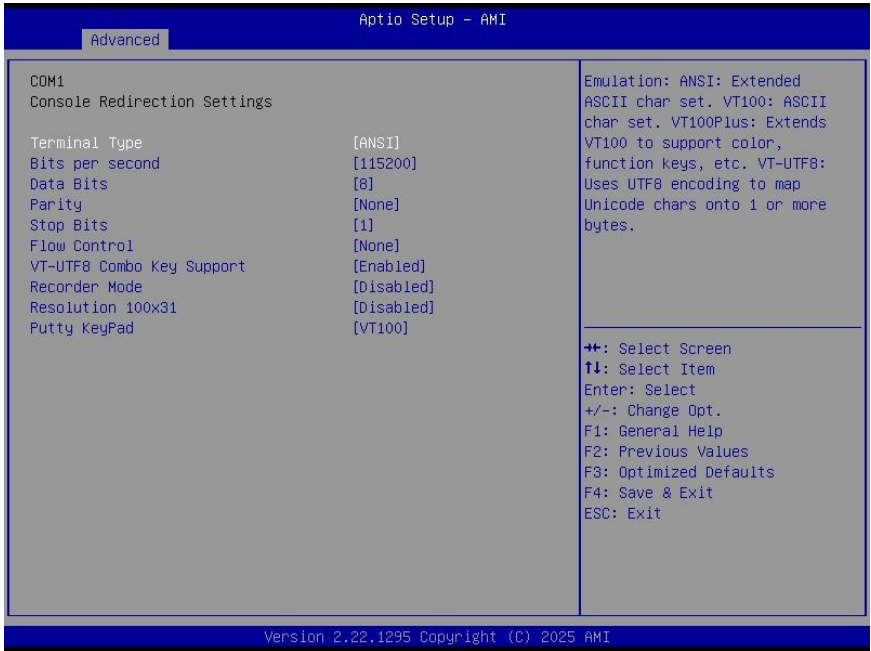

Options Summary	
Terminal Type	ANSI
	VT100
	VT100Plus
	VT-UTF8
<p>Selects the terminal emulation type.</p> <p>ANSI: Extended ASCII character set. VT100: ASCII character set. VT100Plus: Extends VT100 to support color, function keys, and additional features. VT-UTF8: Uses UTF-8 encoding to map Unicode characters to one or more bytes.</p>	

Options Summary	
Bits per second	9600
	19200
	38400
	57600
	115200
	230400
	460800
	921600
Use this item to select serial port transmission speed. The speed must be matched on the other side. Long or noisy lines may require lower speeds.	
Data Bits	7
	8
Parity	None
	Even
	Odd
	Mark
	Space
<p>Selects the parity mode used for serial data transmission to detect transmission errors.</p> <p>None: No parity bit is sent.</p> <p>Even: Parity bit is set to 0 when the number of logical 1s in the data bits is even.</p> <p>Odd: Parity bit is set to 0 when the number of logical 1s in the data bits is odd.</p> <p>Mark: Parity bit is always set to 1.</p> <p>Space: Parity bit is always set to 0.</p> <p>Note: Mark and Space parity do not provide error detection and may be used as an additional data bit.</p>	
Stop Bits	1
	2
<p>Stop bits indicate the end of a serial data packet. (A start bit indicates the beginning). The standard setting is 1 stop bit. Communication with slow devices may require more than 1 stop bit.</p>	
Flow Control	None
	Hardware RTS/CTS
<p>Flow control can prevent data loss from buffer overflow. When sending data, if the receiving buffers are full, a "stop" signal can be sent to stop the data flow. Once the buffers are empty, a "start" signal can be sent to re-start the flow. Hardware flow control uses two wires to send start/stop signals.</p>	
VT-UTF8 Combo Key Support	Disabled
	Enabled
Use this item to enable VT-UTF8 Combination Key Support for ANSI/VT100 terminals.	
Recorder Mode	Disabled
	Enabled

Options Summary	
With this mode enabled only text will be sent. This is to capture Terminal data.	
Resolution 100x31	Disabled
	Enabled
Use this item to enable or disable extended terminal resolution.	
Putty KeyPad	VT100
	LINUX
	XTERMR6
	SCO
	ESCN
	VT400
Use this item to enable or disable extended terminal resolution.	

3.4.13 USB Configuration

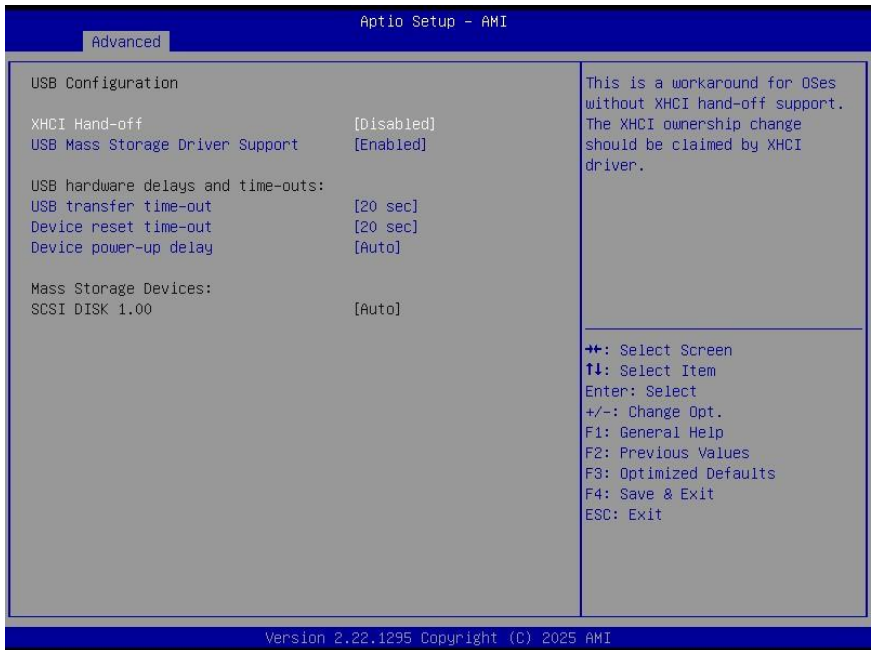

Options Summary	
XHCI Hand-off	Disabled
	Enabled
This is a workaround for OSes without XHCI hand-off support.	

Options Summary	
The XHCI ownership change should be claimed by XHCI driver.	
USB Mass Storage Driver Support	Disabled
	Enabled
Use this item to enable or disable USB Mass storage driver support.	
USB Transfer time-out	1 sec
	5 sec
	10 sec
	20 sec
Use this item to set the time-out value for control, bulk, and interrupt transfers	
Device reset time-out	10 sec
	20 sec
	30 sec
	40 sec
Use this item to set USB mass storage device start unit command time-out.	
Device power-up delay	Auto
	Manual
Use this item to set maximum time the device will take before it properly reports itself to the host controller. 'Auto' uses default value: for a root port it is 100 ms, for a hub port the delay is taken from hub descriptor.	

3.4.14 Network Stack



Options Summary	
Network Stack	Disabled
	Enabled
Enable or disable UEFI Network Stack.	

When **Network Stack** set as **[Enabled]**

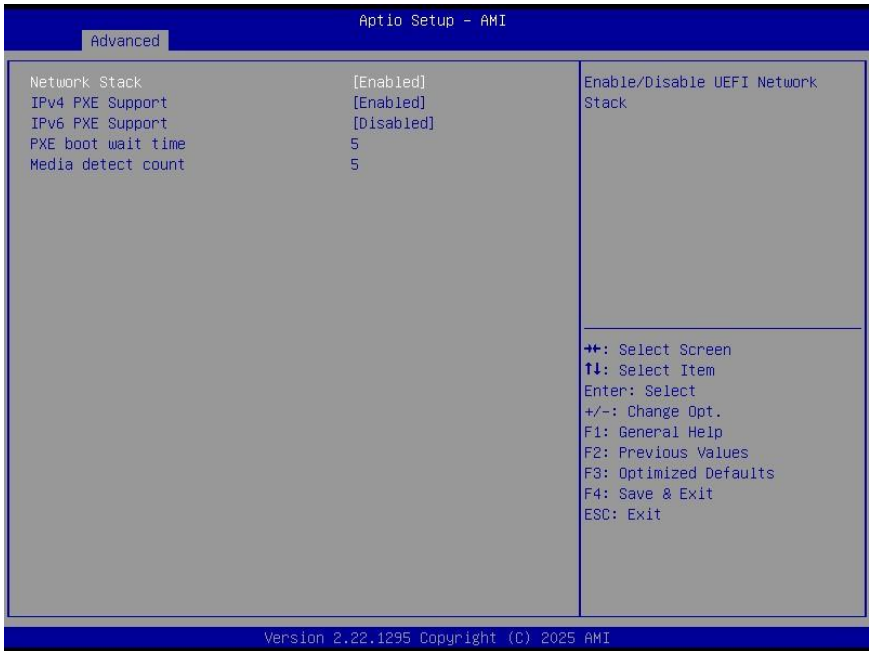

Options Summary	
IPv4 PXE Support	Enabled
	Disabled
Enables or disables IPv4 PXE boot support.	
IPv6 PXE Support	Disabled
	Enabled
Enables or disables IPv6 PXE boot support.	
PXE Boot Wait Time	5
Use either [+] or [-] or numeric keys to set the value. PXE boot wait time. Range: 0–255 seconds	
Media Detect Count	5
Use this item to set number of times presence of media will be checked. Use either [+] or [-] or numeric keys to set the value. Range: 0–255 seconds	

3.4.15 NVMe Configuration



3.4.15.1 Intel (R) Ethernet Controller I226-LM

The screenshot shows the 'Advanced' menu in the Aptio Setup - AMI BIOS. The menu is divided into two columns. The left column lists system information for the Intel(R) 2.5G Ethernet Controller I226-LM, including the driver version (0.10.06), device name, link status (Disconnected), and MAC address (00:30:18:14:27:26). The right column contains a list of navigation and function keys: F4 for Select Screen, F5 for Select Item, Enter for Select, +/- for Change Opt., F1 for General Help, F2 for Previous Values, F3 for Optimized Defaults, F4 for Save & Exit, and ESC for Exit. At the bottom of the screen, the version '2.22.1295' and copyright 'Copyright (C) 2025 AMI' are displayed.

Aptio Setup - AMI	
Advanced	
UEFI Driver	Intel(R) 2.5G Ethernet Controller 0.10.06
Device Name	Intel(R) Ethernet Controller I226-LM
Link Status	[Disconnected]
MAC Address	00:30:18:14:27:26

Navigation and Function Keys:

- ↔: Select Screen
- ⌵: Select Item
- Enter: Select
- +/-: Change Opt.
- F1: General Help
- F2: Previous Values
- F3: Optimized Defaults
- F4: Save & Exit
- ESC: Exit

Version 2.22.1295 Copyright (C) 2025 AMI

3.4.15.2 Intel (R) Ethernet Controller I226-V

The screenshot shows the 'Advanced' menu of the Aptio Setup - AMI BIOS. The settings for the Intel(R) 2.5G Ethernet Controller I226-V are displayed. The link status is [Disconnected]. The MAC address is 00:30:18:14:27:27. A legend of keyboard shortcuts is provided on the right side of the screen.

Aptio Setup - AMI	
Advanced	
UEFI Driver	Intel(R) 2.5G Ethernet Controller 0.10.06
Device Name	Intel(R) Ethernet Controller I226-V
Link Status	[Disconnected]
MAC Address	00:30:18:14:27:27

↔: Select Screen
↑↓: Select Item
Enter: Select
+/-: Change Opt.
F1: General Help
F2: Previous Values
F3: Optimized Defaults
F4: Save & Exit
ESC: Exit

Version 2.22.1295 Copyright (C) 2025 AMI

3.4.15.3 Intel (R) Ethernet Controller I226-V

The screenshot shows the 'Advanced' menu in the Aptio Setup - AMI BIOS. The menu is divided into two columns. The left column lists system information for the Intel(R) 2.5G Ethernet Controller I226-V, including the driver version (0.10.06), device name, link status (Disconnected), and MAC address (00:30:18:14:27:28). The right column contains a list of navigation and function keys: F4 for Select Screen, F5 for Select Item, Enter for Select, +/- for Change Opt., F1 for General Help, F2 for Previous Values, F3 for Optimized Defaults, F4 for Save & Exit, and ESC for Exit. At the bottom of the screen, the version '2.22.1295' and copyright 'Copyright (C) 2025 AMI' are displayed.

Aptio Setup - AMI	
Advanced	
UEFI Driver	Intel(R) 2.5G Ethernet Controller 0.10.06
Device Name	Intel(R) Ethernet Controller I226-V
Link Status	[Disconnected]
MAC Address	00:30:18:14:27:28

Navigation and Function Keys:

- F4: Select Screen
- F5: Select Item
- Enter: Select
- +/-: Change Opt.
- F1: General Help
- F2: Previous Values
- F3: Optimized Defaults
- F4: Save & Exit
- ESC: Exit

Version 2.22.1295 Copyright (C) 2025 AMI

3.5 Setup Submenu: Chipset



The Chipset menu items allow you to change the settings for the chipset.

3.5.1 System Agent (SA) Configuration 1

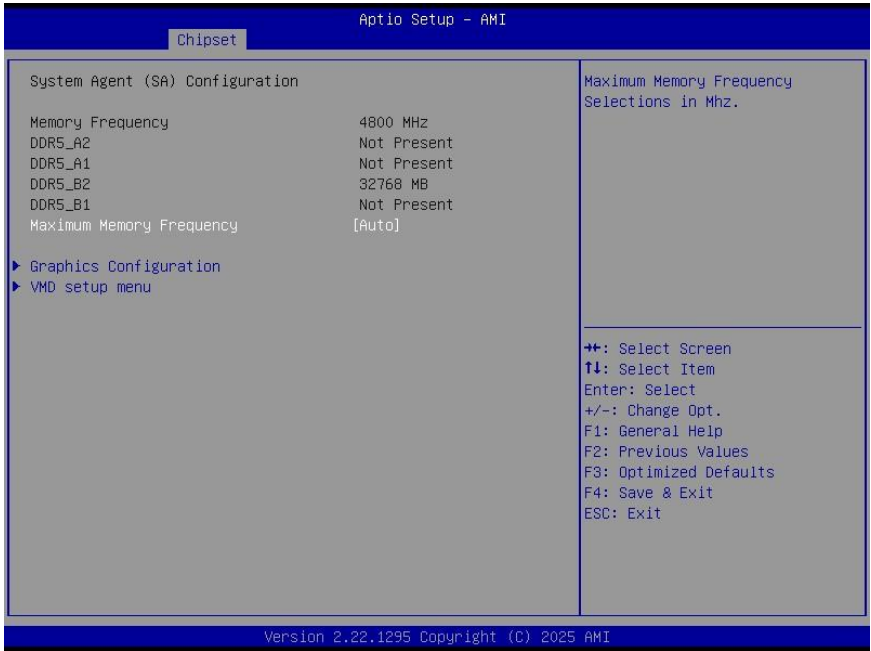

Options Summary	
Maximum Memory Frequency	Auto
Use this item to Maximum Memory Frequency selections in MHz.	
The optional settings are: [Auto]; [4000]; [4400]; [4800]; [5200]; [5600] ; [6000] ; [6400].	

3.5.2 System Agent (SA) Configuration 2

Chipset			Aptio Setup - AMI	
Memory Configuration				Select AUTO set IGD to be Primary Display if no external Graphics Device connected otherwise external Graphics Device detected on first PCIe port will be Primary Display or Select IGBX for IGD to be Primary Display Or Select HG for Hybrid Gfx. ++: Select Screen T↓: Select Item Enter: Select +/-: Change Opt. F1: General Help F2: Previous Values F3: Optimized Defaults F4: Save & Exit ESC: Exit
Memory Frequency	4800 MHz			
Total Memory	16384 MB			
MC 0 Ch 0 DIMM 0	Not Populated / Disabled			
MC 0 Ch 1 DIMM 0	Populated & Enabled			
Size	16384 MB (DDR5)			
Number of Ranks	1			
Manufacturer	Unknown			
Primary Display	[Auto]			
PCIEX16 Gen Speed	[Auto]			
CH7513	[Disabled]			
Version 2.22.1297 Copyright (C) 2025 AMI				

Options Summary	
Primary Display	Auto
	HDMI
	DisplayPort
	LVDS/eDP
Allows selection of the primary display device.	

3.5.3 Graphics Configuration

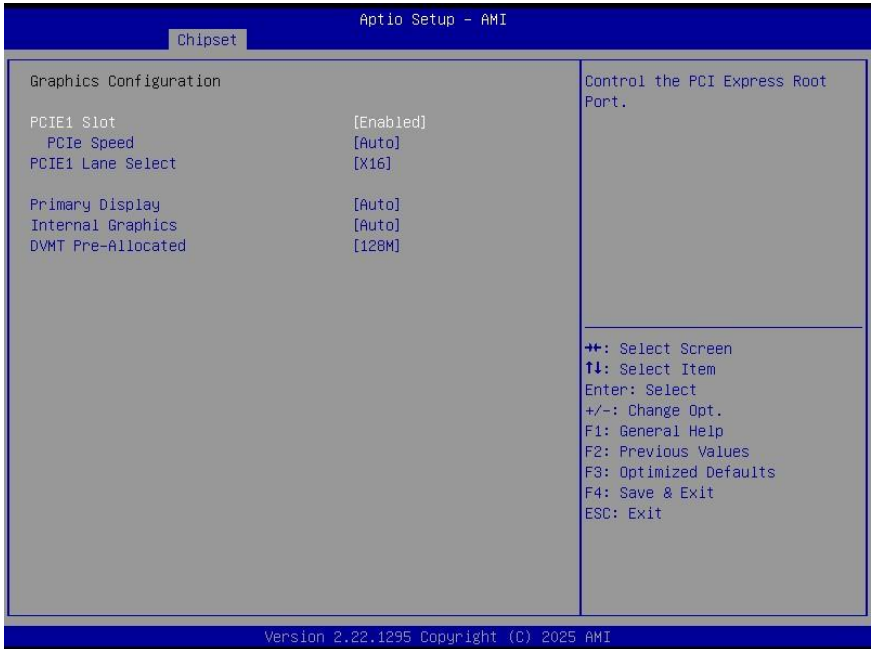

Options Summary	
PCIE1 Slot	Enabled
	Disabled
Use this item to control the PCI Express root port.	
PCIE1 Speed	Auto
	Gen1
	Gen2
	Gen3
	Gen4
PCIE1 Slot Lane Select	X16
	X8/X8
Primary Display	Auto
	IGFX
Use this item to select which graphics device should be primary display.	
DVMT Pre-Allocated	32M
	64M
	96M

Options Summary

128M

Use this item to select DVMT 5.0 Pre-Allocated (Fixed) graphics memory size used by the internal graphics device.

3.5.4 VMD Setup Menu

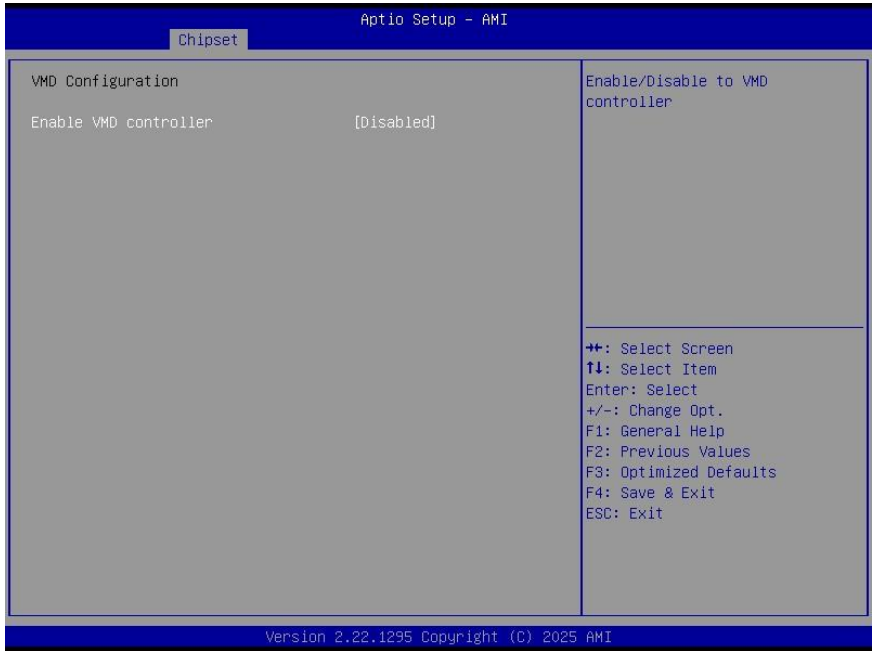

Options Summary

Enable VMD controller

Disabled

Enabled

Use this item to enable/disable to VMD controller.

Aptio Setup - AMI

Chipset

<p>VMD Configuration</p> <p>Enable VMD controller [Enabled]</p> <p>Enable VMD Global Mapping [Enabled]</p> <p>Map PCH SATA Controller Under VMD [Enabled]</p>	<p>Enable/Disable to VMD Global Mapping</p> <hr/> <p> ++: Select Screen ↑↓: Select Item Enter: Select +/-: Change Opt. F1: General Help F2: Previous Values F3: Optimized Defaults F4: Save & Exit ESC: Exit </p>
---	---

Version 2.22.1295 Copyright (C) 2025 AMI

Options Summary	
Enable VMD Global Mapping	Disabled
	Enabled
Use this item to enable/disable to VMD global mapping.	
Map this Root Port under VMD	Disabled
	Enabled
Use this item to Map/Un-Map this root port to VMD.	

3.5.5 PCH-IO Configuration



3.5.5.1 SATA Controller(s)

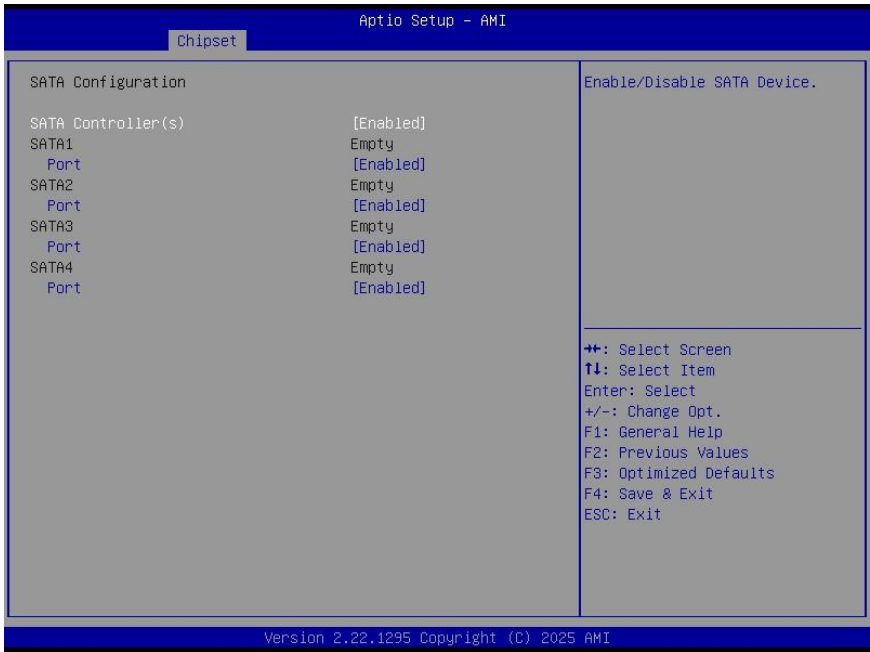

Options Summary	
SATA1	Enabled
	Disabled
Enable/Disable SATA Port.	
SATA2	Enabled
	Disabled
Enable/Disable SATA Port.	
SATA3	Enabled
	Disabled
Enable/Disable SATA Port.	
SATA4	Enabled
	Disabled
Enable/Disable SATA Port.	
HD Audio	Enabled
	Disabled
HD-Audio Device Control: Disabled – HDA is unconditionally disabled.	

Options Summary

Enabled – HDA is unconditionally enabled.

System State After Power Failure

Always On

Always Off

Former State

Use this item to specify what state to go to when power is re-applied after a power failure (G3 state).

3.6 Setup Submenu: Security



Administrator Password

If you have set an administrator password, we recommend that you enter the administrator password for accessing the system. Otherwise, you might be able to see or change only selected fields in the BIOS setup program.

To set an administrator password:

If there is no password present on system, please press [Enter] to create new administrator password. If password is present on system, please press [Enter] to verify old password then to clear/change password. Press again to confirm the new administrator password.

To change an administrator password:

- 1 Select the **Administrator Password** item and press <Enter>.
- 2 From the **Enter Current Password** box, key in the current password, then press <Enter>.

- 3 From the **Create New Password** box, key in a new password, then press **<Enter>**
- 4 Confirm the password when prompted.

To clear the administrator password, follow the same steps as in changing an administrator password, but press **<Enter>** when prompted to create/confirm the password. After you clear the password, the **Administrator Password** item on top of the screen shows **Not Installed**.

User Password

If you have set a user password, you must enter the user password for accessing the system. The **User Password** item on top of the screen shows the default **Not Installed**. After you set a password, this item shows **Installed**.

To set a user password:

- 1 Select the **User Password** item and press **<Enter>**.
- 2 From the **Create New Password** box, key in a password, then press **<Enter>**.
- 3 Confirm the password when prompted.

To change a user password:

- 1 Select the **User Password** item and press **<Enter>**.
- 2 From the **Enter Current Password** box, key in the current password, then press **<Enter>**.
- 3 From the **Create New Password** box, key in a new password, then press **<Enter>**
- 4 Confirm the password when prompted.

To clear the user password, follow the same steps as in changing a user password, but press **<Enter>** when prompted to create/confirm the password. After you clear the password, the **User Password** item on top of the screen shows **Not Installed**.

3.6.1 Secure Boot

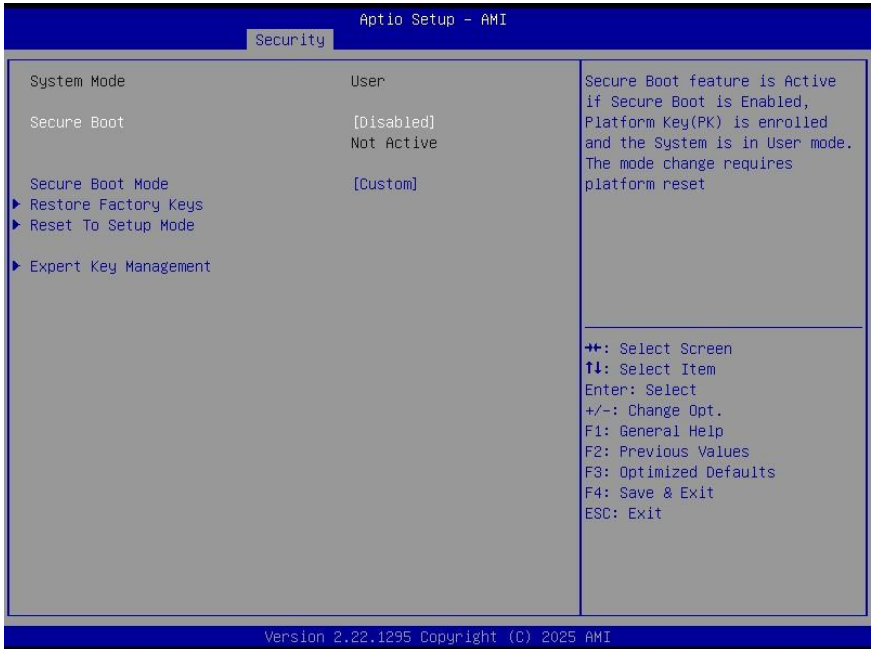

Options Summary	
Secure Boot	Disabled
	Enabled
Secure Boot feature is Active if Secure Boot is Enabled, Platform Key (PK) is enrolled and the System is in User mode. The mode change requires platform reset	
Secure Boot Status	Not Active
	Active
Displays the current Secure Boot state.	
Secure Boot Mode	Custom
	Standard
Secure Boot mode options: Standard or Custom. In Custom mode, Secure Boot Policy variables can be configured by a physically present user without full authentication	
Restore Factory Keys	Yes
	No
Use this item to force system to User Mode, to install factory default Secure Boot key databases.	

Options Summary

Reset to Setup Mode

Yes

No

Delete all Secure Boot key databases from NVRAM

3.6.2 Key Management

The screenshot shows the 'Security' menu in the Aptio Setup - AMI utility. The 'Factory Key Provision' option is currently set to '[Enabled]'. Below this, there are several expandable options: 'Restore Factory Keys', 'Reset To Setup Mode', 'Enroll Efi Image', and 'Export Secure Boot variables'. A table lists the 'Secure Boot variable' details, including 'Platform Key (PK)', 'Key Exchange Keys (KEK)', 'Authorized Signatures (db)', 'Forbidden Signatures(dbx)', 'Authorized TimeStamps(dbt)', and 'OsRecovery Signatures(dbr)'. The table columns are 'Size', 'Keys', and 'Key Source'. To the right of the table, there is a text box explaining that the factory default Secure Boot keys will be installed after a platform reset while the system is in Setup mode. At the bottom right, a list of navigation keys is provided: ++ for Select Screen, F1 for Select Item, Enter for Select, +/- for Change Opt., F1 for General Help, F2 for Previous Values, F3 for Optimized Defaults, F4 for Save & Exit, and ESC for Exit. The version number 'Version 2.22.1295 Copyright (C) 2025 AMI' is displayed at the bottom of the screen.

Secure Boot variable	Size	Keys	Key Source
▶ Platform Key (PK)	876	1	Factory
▶ Key Exchange Keys (KEK)	3066	2	Factory
▶ Authorized Signatures (db)	7009	5	Factory
▶ Forbidden Signatures(dbx)	17836	371	Factory
▶ Authorized TimeStamps(dbt)	0	0	No Keys
▶ OsRecovery Signatures(dbr)	0	0	No Keys

Options Summary

Factory Key Provision

Enabled

Disabled

Allows you to enable or disable factory key provisioning for Secure Boot.

3.6.3 Restore Factory Keys

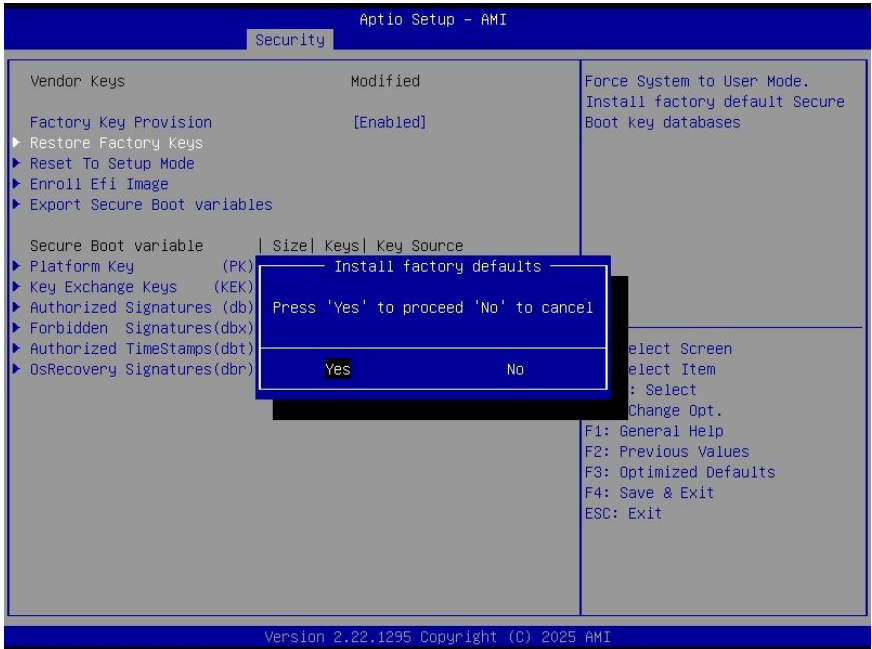

Options Summary	
Install factory defaults	Yes
	No
Force System to User Mode. Install factory default Secure Boot key databases.	

3.6.4 Reset To Setup Mode

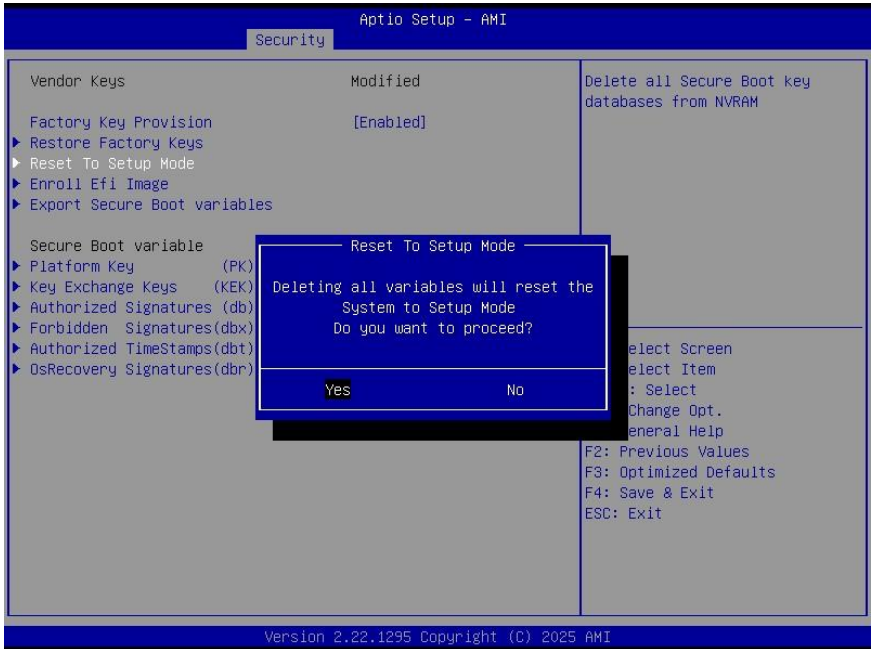

Options Summary	
Install factory defaults	Yes
	No
Delete all Secure Boot key databases from NVRAM.	

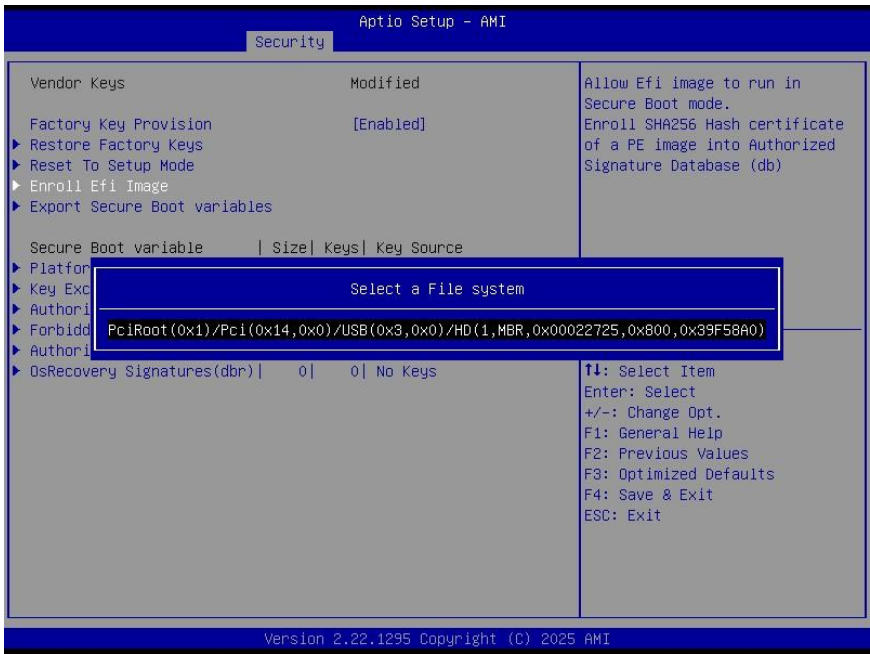

Options Summary

Enroll EFI Image

Allow Efi image to run in Secure Boot mode.

Enroll SHA256 Hash certificate of a PE image into Authorized Signature Database (db)

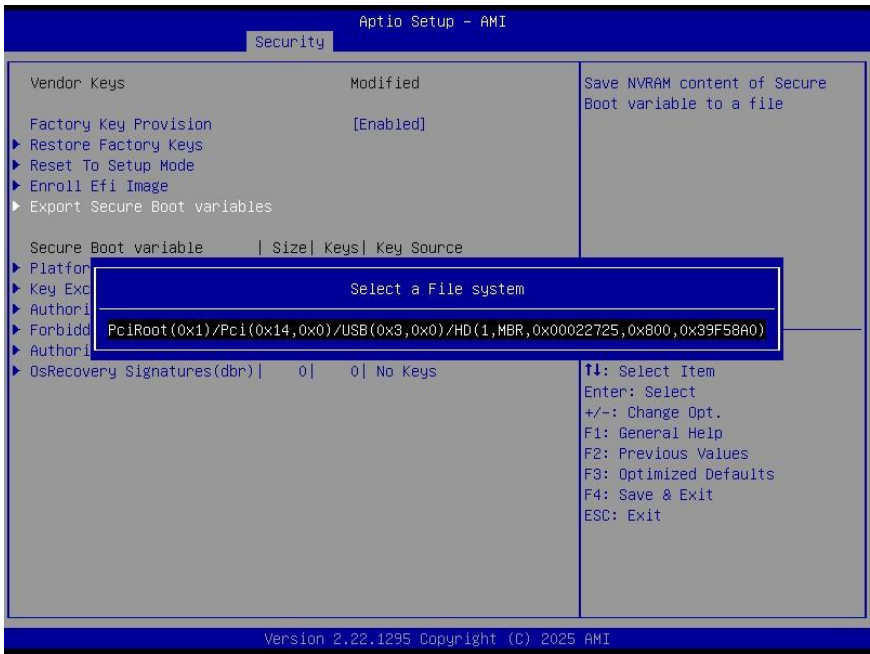

Options Summary

Export Secure Boot Variables

Save NVRAM content of Secure Boot variable to a file.

3.6.5 Platform Key (PK)

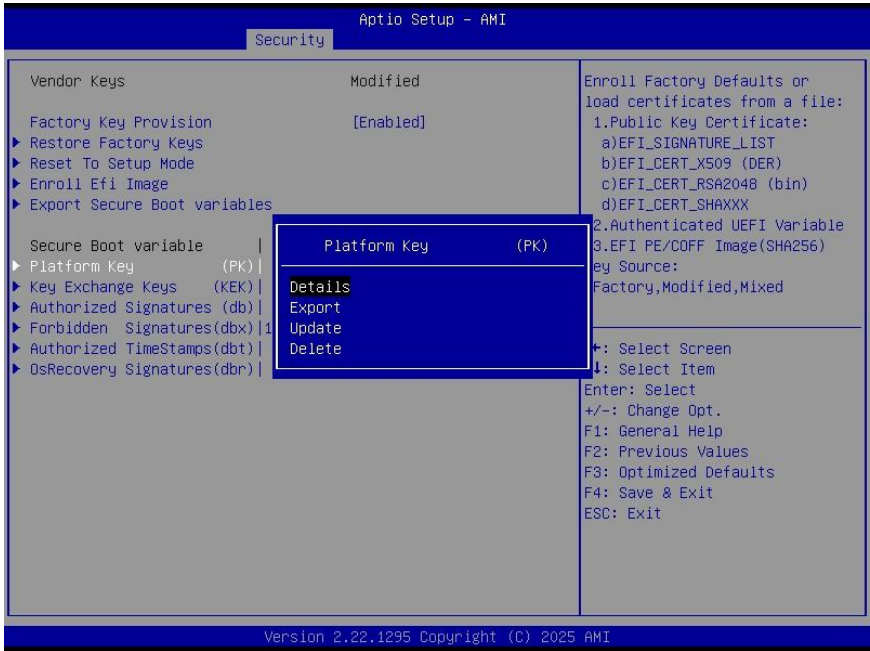

Options Summary	
Platform Key (PK)	Details
	Export
	Update
	Delete
Enroll Factory Defaults or load certificates from a file: 1. Public Key Certificate: a) EFI_SIGNATURE_LIST b) EFI_CERT_X509 (DER) c) EFI_CERT_RSA2048 (bin) d) EFI_CERT_SHAXXX 2. Authenticated UEFI Variable 3. EFI PE/COFF Image (SHA256) Key Source: Factory, Modified, Mixed	

3.6.6 Key Exchange Keys

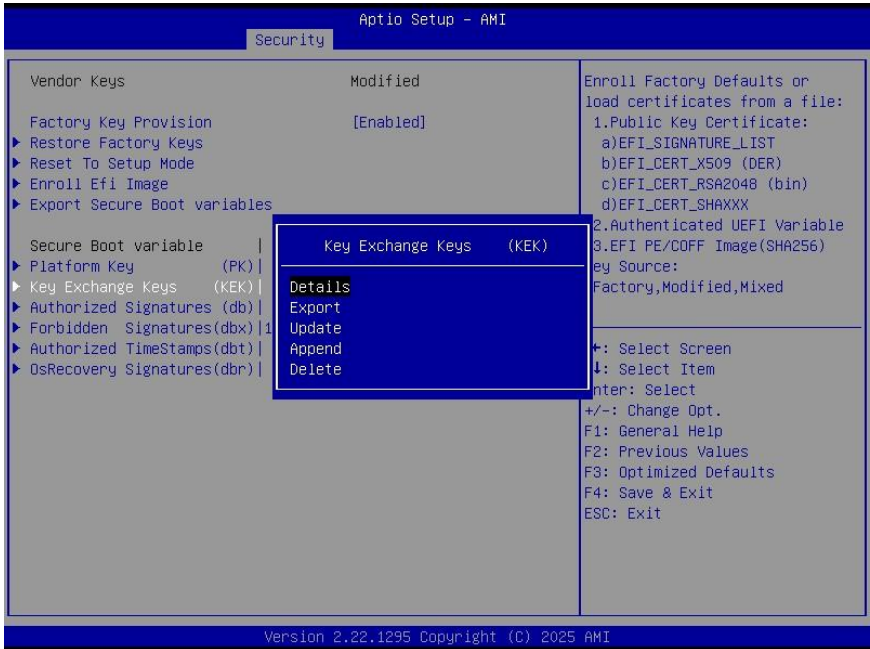

Options Summary	
Key Exchange Keys (KEK)	Details
	Export
	Update
	Append
	Delete
Enroll Factory Defaults or load certificates from a file: 1. Public Key Certificate: a) EFI_SIGNATURE_LIST b) EFI_CERT_X509 (DER) c) EFI_CERT_RSA2048 (bin) d) EFI_CERT_SHAXXX 2. Authenticated UEFI Variable 3.EFI PE/COFF Image (SHA256) Key Source: Factory, Modified, Mixed	

3.6.7 Authorized Signatures

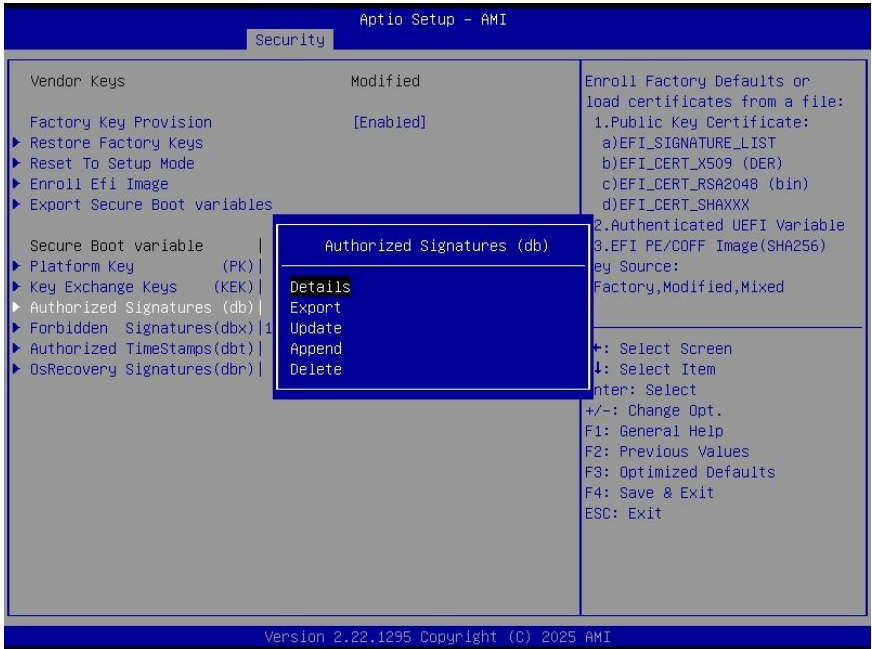

Options Summary	
Authorized Signatures (db)	Details
	Export
	Update
	Append
	Delete
Enroll Factory Defaults or load certificates from a file: 1. Public Key Certificate: a) EFI_SIGNATURE_LIST b) EFI_CERT_X509 (DER) c) EFI_CERT_RSA2048 (bin) d) EFI_CERT_SHAXXX 2. Authenticated UEFI Variable 3. EFI PE/COFF Image (SHA256) Key Source: Factory, Modified, Mixed	

3.6.8 Forbidden Signatures

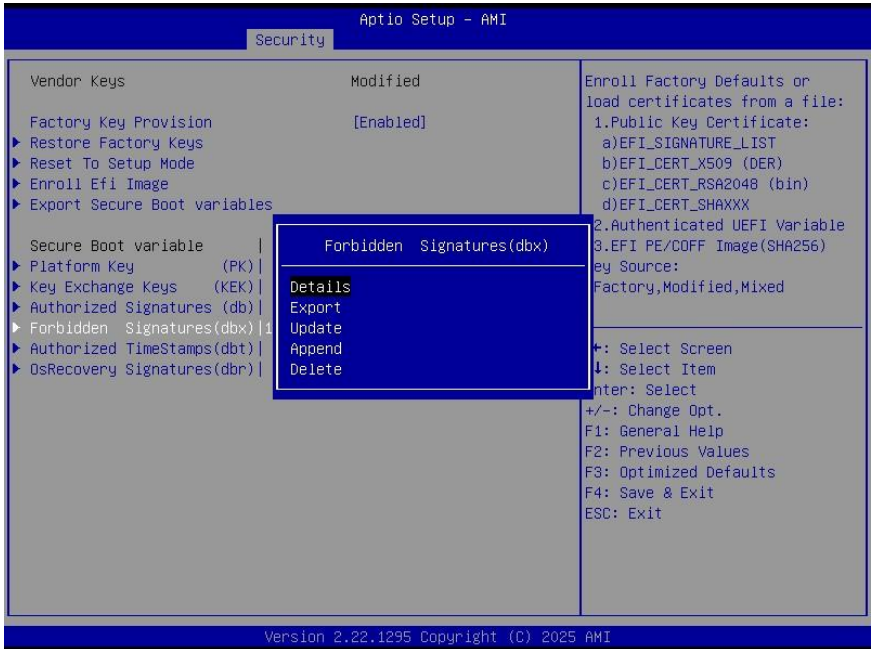

Options Summary	
Forbidden Signatures (dbx)	Details
	Export
	Update
	Append
	Delete
Enroll Factory Defaults or load certificates from a file: 1. Public Key Certificate: a) EFI_SIGNATURE_LIST b) EFI_CERT_X509 (DER) c) EFI_CERT_RSA2048 (bin) d) EFI_CERT_SHAXXX 2. Authenticated UEFI Variable 3. EFI PE/COFF Image (SHA256) Key Source: Factory, Modified, Mixed	

3.6.9 Authorized TimeStamps

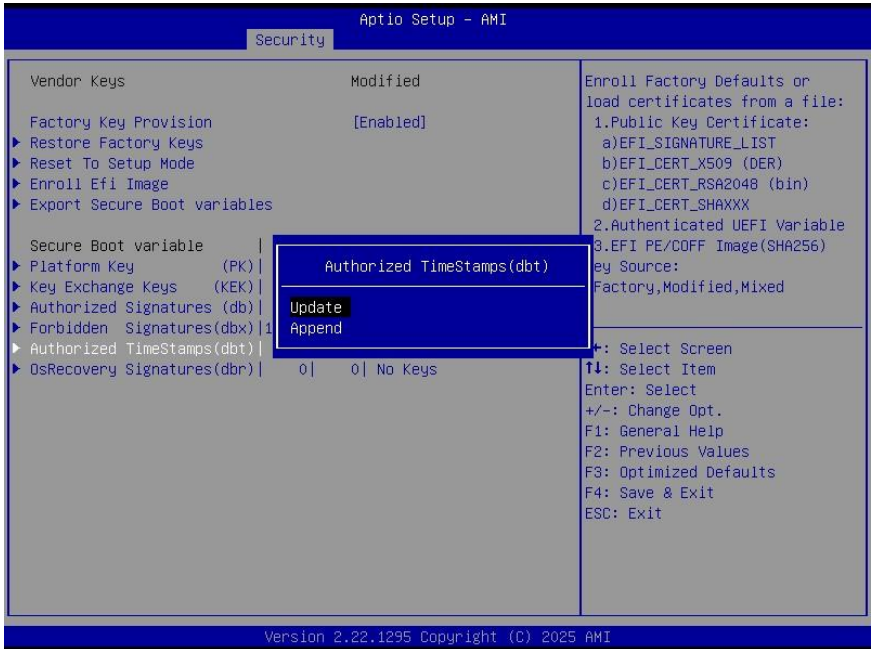

Options Summary	
Authorized TimeStamps (dbt)	Update
	Append
<p>Enroll Factory Defaults or load certificates from a file:</p> <p>1. Public Key Certificate:</p> <p>a) EFI_SIGNATURE_LIST</p> <p>b) EFI_CERT_X509 (DER)</p> <p>c) EFI_CERT_RSA2048 (bin)</p> <p>d) EFI_CERT_SHAXXX</p> <p>2. Authenticated UEFI Variable</p> <p>3. EFI PE/COFF Image (SHA256)</p> <p>Key Source: Factory, Modified, Mixed</p>	

3.6.10 OsRecovery Signatures

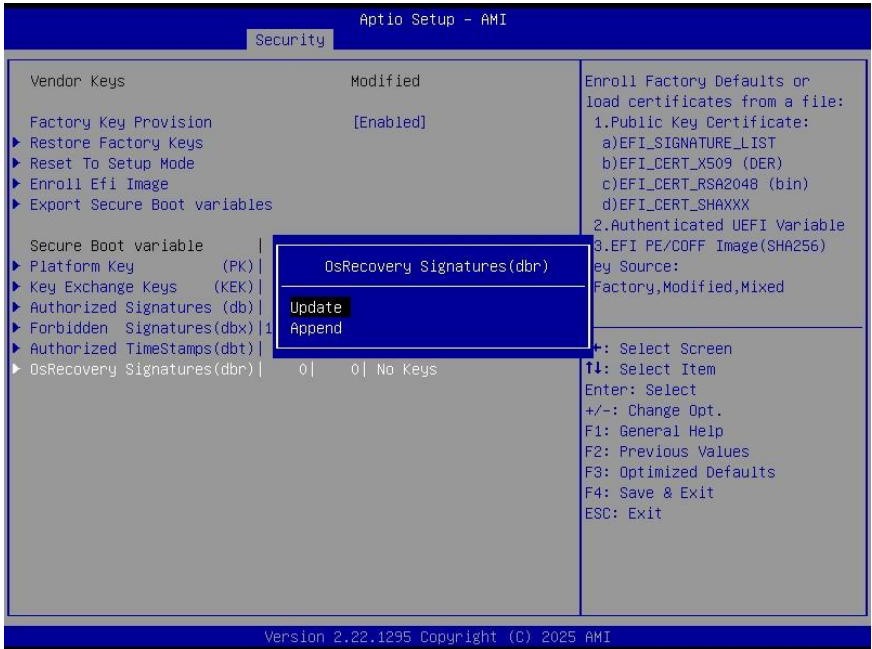

Options Summary	
OsRecovery Signatures (dbr)	Update
	Append
Enroll Factory Defaults or load certificates from a file: 1. Public Key Certificate: a) EFI_SIGNATURE_LIST b) EFI_CERT_X509 (DER) c) EFI_CERT_RSA2048 (bin) d) EFI_CERT_SHAXXX 2. Authenticated UEFI Variable 3. EFI PE/COFF Image (SHA256) Key Source: Factory, Modified, Mixed	

3.7 Setup Submenu: Boot

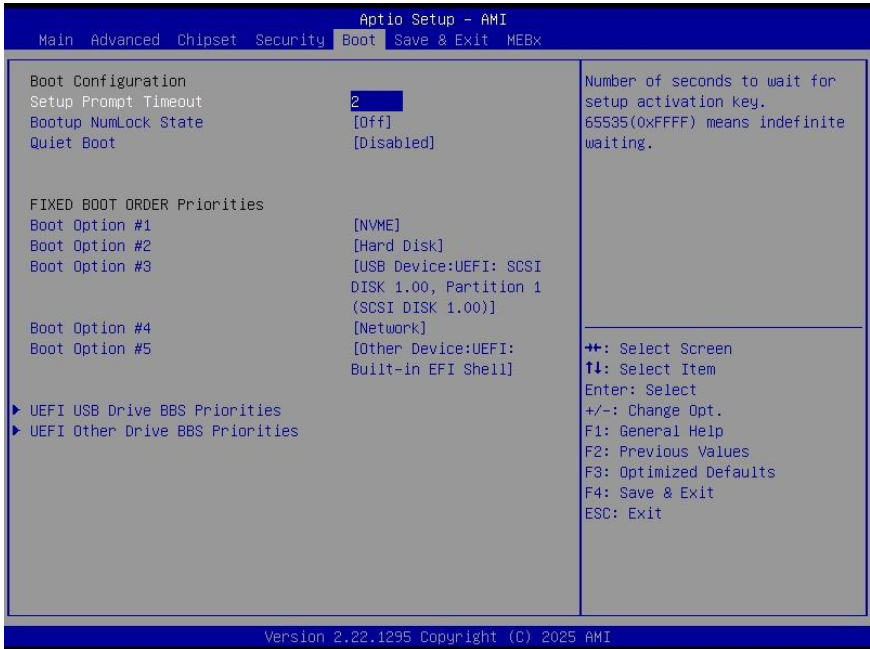

Options Summary	
Setup Prompt Timeout	2
Use this item to set number of seconds to wait for setup activation key. 65535 (0xFFFF) means indefinite waiting.	
Quiet Boot	Disabled
	Enabled
Enables/disables Quiet Boot option.	
FIXED BOOT ORDER Priorities	
Sets the system boot order.	

3.7.1 BBS Priorities

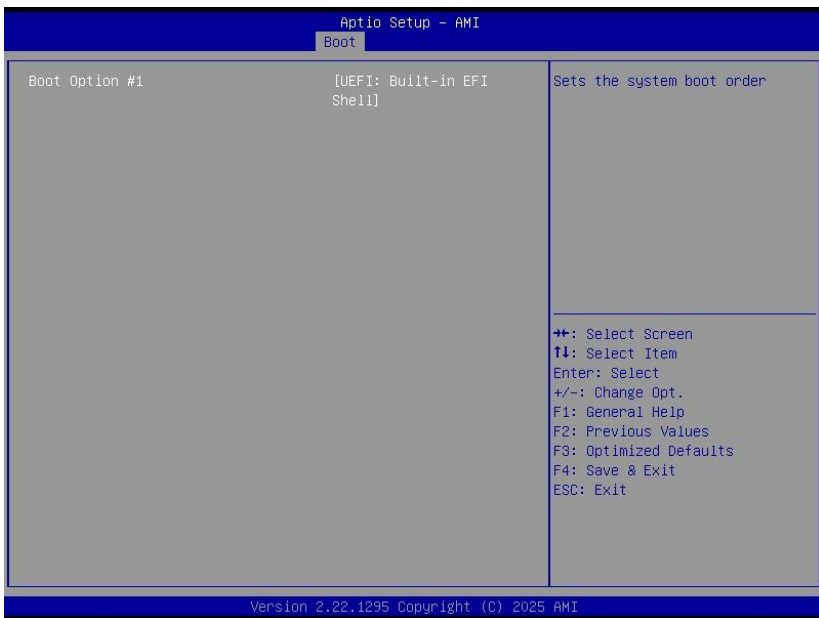
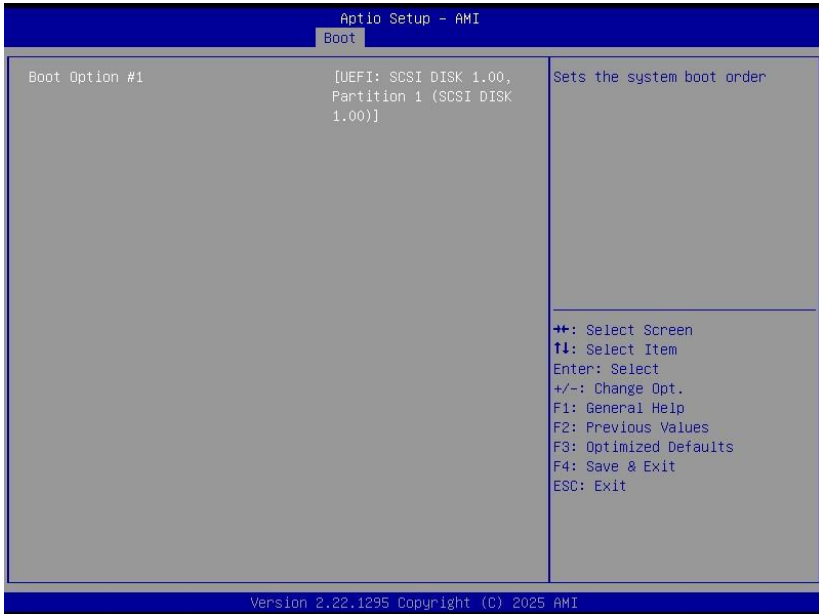

3.8 Setup Submenu: Save & Exit

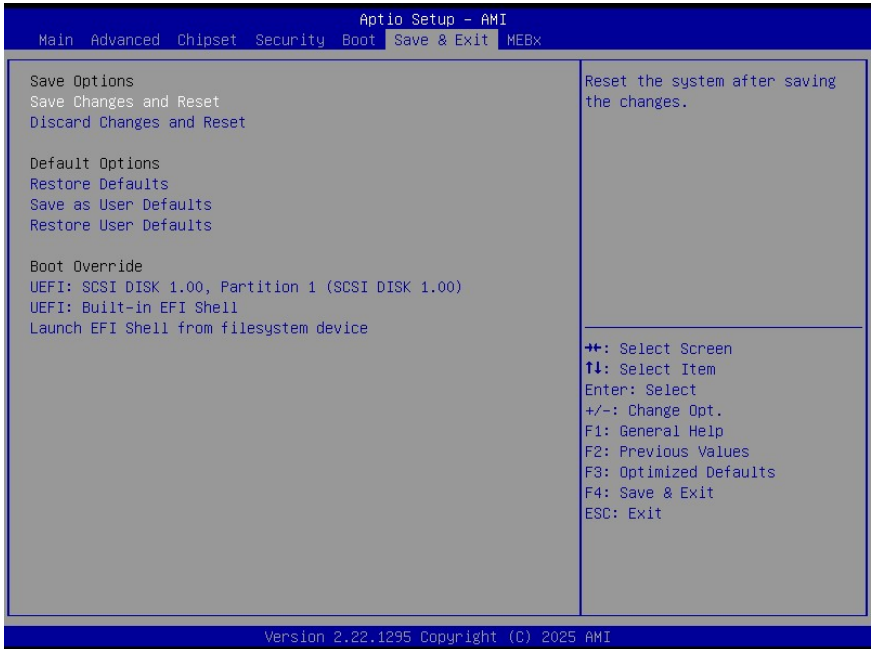

3.9 Setup Submenu: MEBx



The MEBx menu items allow you to view and change MEBx configurations.

Appendix

Notices

FCC Statement

Warning!



This device complies with Part 15 FCC Rules. Operation is subject to the following two conditions: (1) this device may not cause harmful interference, and (2) this device must accept any interference received including interference that may cause undesired operation.

Caution:

There is a danger of explosion if the battery is incorrectly replaced. Replace only with the same or equivalent type recommended by the manufacturer. Dispose of used batteries according to the manufacturer's instructions and your local government's recycling or disposal directives.

Attention:

Il y a un risque d'explosion si la batterie est remplacée de façon incorrecte. Ne la remplacer qu'avec le même modèle ou équivalent recommandé par le constructeur. Recycler les batteries usées en accord avec les instructions du fabricant et les directives gouvernementales de recyclage.

China RoHS Requirements (CN)

产品中有毒有害物质或元素名称及含量

AAEON 主板/子板/背板

QO4-381 Rev.A2

部件名称	有毒有害物质或元素					
	铅 (Pb)	汞 (Hg)	镉 (Cd)	六价铬 (Cr(VI))	多溴联苯 (PBB)	多溴二苯醚 (PBDE)
印刷电路板 及其电子组件	×	○	○	○	○	○
外部信号 连接器及线材	×	○	○	○	○	○
<p>本表格依据 SJ/T 11364 的规定编制。</p> <p>○：表示该有毒有害物质在该部件所有均质材料中的含量均在GB/T 26572标准规定的限量要求以下。</p> <p>×：表示该有害物质的某一均质材料超出了GB/T 26572的限量要求，然而该部件仍符合欧盟指令2011/65/EU 的规范。</p> <p>环保使用期限(EFUP (Environmental Friendly Use Period))：10年</p> <p>备注：此产品所标示之环保使用期限，系指在一般正常使用状况下。</p>						

China RoHS Requirements (EN)

Name and content of hazardous substances in product

AAEON Main Board/Daughter Board/Backplane

QO4-381 Rev.A2

Part Name	Hazardous Substances					
	铅 (Pb)	汞 (Hg)	镉 (Cd)	六价铬 (Cr(VI))	多溴联苯 (PBB)	多溴二苯 醚(PBDE)
PCB Assemblies	×	○	○	○	○	○
Connector and Cable	×	○	○	○	○	○

The table is prepared in accordance with the provisions of SJ/T 11364.

○: Indicates that said hazardous substance contained in all of the homogenous materials for this product is below the limit requirement of GB/T 26572.

×: Indicates that said hazardous substance contained in at least one of the homogenous materials used for this part is above the limit requirement of GB/T 26572. But this product still be compliance with 2011/65/EU Directive (allowed with 2011/65/EU Annex III of RoHS exemption with number 6(c),7(a),7(c)-1).

EFUP (Environment Friendly Use Period) value: 10 years

Notes: This product defined period of use is under normal condition.