

# ASDM-S-KBU

---

Smart Display Module

User's Manual 1<sup>st</sup> Ed

## Copyright Notice

---

This document is copyrighted, 2019. All rights are reserved. The original manufacturer reserves the right to make improvements to the products described in this manual at any time without notice.

No part of this manual may be reproduced, copied, translated, or transmitted in any form or by any means without the prior written permission of the original manufacturer. Information provided in this manual is intended to be accurate and reliable. However, the original manufacturer assumes no responsibility for its use, or for any infringements upon the rights of third parties that may result from its use.

The material in this document is for product information only and is subject to change without notice. While reasonable efforts have been made in the preparation of this document to assure its accuracy, AAEON assumes no liabilities resulting from errors or omissions in this document, or from the use of the information contained herein.

AAEON reserves the right to make changes in the product design without notice to its users.

## Acknowledgement

---

All other products' name or trademarks are properties of their respective owners.

- Microsoft Windows is a registered trademark of Microsoft Corp.
- Intel, Pentium, Celeron, and Xeon are registered trademarks of Intel Corporation
- Core, Atom are trademarks of Intel Corporation
- ITE is a trademark of Integrated Technology Express, Inc.
- IBM, PC/AT, PS/2, and VGA are trademarks of International Business Machines Corporation.

All other product names or trademarks are properties of their respective owners. No ownership is implied or assumed for products, names or trademarks not herein listed by the publisher of this document.

## Packing List

---

Before setting up your product, please make sure the following items have been shipped:

Item	Quantity
● ASDM-S-KBU	1

If any of these items are missing or damaged, please contact your distributor or sales representative immediately.

## About this Document

---

This User's Manual contains all the essential information, such as detailed descriptions and explanations on the product's hardware and software features (if any), its specifications, dimensions, jumper/connector settings/definitions, and driver installation instructions (if any), to facilitate users in setting up their product.

Users may refer to the product page at [AAEON.com](http://AAEON.com) for the latest version of this document.

## Safety Precautions

---

Please read the following safety instructions carefully. It is advised that you keep this manual for future references

1. All cautions and warnings on the device should be noted.
2. Make sure the power source matches the power rating of the device.
3. Position the power cord so that people cannot step on it. Do not place anything over the power cord.
4. Always completely disconnect the power before working on the system's hardware.
5. No connections should be made when the system is powered as a sudden rush of power may damage sensitive electronic components.
6. If the device is not to be used for a long time, disconnect it from the power supply to avoid damage by transient over-voltage.
7. Always disconnect this device from any AC supply before cleaning.
8. While cleaning, use a damp cloth instead of liquid or spray detergents.
9. Make sure the device is installed near a power outlet and is easily accessible.
10. Keep this device away from humidity.
11. Place the device on a solid surface during installation to prevent falls
12. Do not cover the openings on the device to ensure optimal heat dissipation.
13. Watch out for high temperatures when the system is running.
14. Do not touch the heat sink or heat spreader when the system is running
15. Never pour any liquid into the openings. This could cause fire or electric shock.
16. As most electronic components are sensitive to static electrical charge, be sure to ground yourself to prevent static charge when installing the internal components. Use a grounding wrist strap and contain all electronic components in any static-shielded containers.

17. If any of the following situations arises, please the contact our service personnel:
  - i. Damaged power cord or plug
  - ii. Liquid intrusion to the device
  - iii. Exposure to moisture
  - iv. Device is not working as expected or in a manner as described in this manual
  - v. The device is dropped or damaged
  - vi. Any obvious signs of damage displayed on the device
18. **DO NOT LEAVE THIS DEVICE IN AN UNCONTROLLED ENVIRONMENT WITH TEMPERATURES BEYOND THE DEVICE'S PERMITTED STORAGE TEMPERATURES (SEE CHAPTER 1) TO PREVENT DAMAGE.**

### **Warning!**



This device complies with Part 15 FCC Rules. Operation is subject to the following two conditions: (1) this device may not cause harmful interference, and (2) this device must accept any interference received including interference that may cause undesired operation.

### **Caution:**

*There is a danger of explosion if the battery is incorrectly replaced. Replace only with the same or equivalent type recommended by the manufacturer. Dispose of used batteries according to the manufacturer's instructions and your local government's recycling or disposal directives.*

### **Attention:**

*Il y a un risque d'explosion si la batterie est remplacée de façon incorrecte. Ne la remplacer qu'avec le même modèle ou équivalent recommandé par le constructeur. Recycler les batteries usées en accord avec les instructions du fabricant et les directives gouvernementales de recyclage.*



## China RoHS Requirements (CN)

产品中有毒有害物质或元素名称及含量

AAEON Main Board/ Daughter Board/ Backplane

部件名称	有毒有害物质或元素					
	铅 (Pb)	汞 (Hg)	镉 (Cd)	六价铬 (Cr(VI))	多溴联苯 (PBB)	多溴二苯醚 (PBDE)
印刷电路板 及其电子组件	×	○	○	○	○	○
外部信号 连接器及线材	×	○	○	○	○	○
<p>○：表示该有毒有害物质在该部件所有均质材料中的含量均在 SJ/T 11363-2006 标准规定的限量要求以下。</p> <p>X：表示该有毒有害物质至少在该部件的某一均质材料中的含量超出 SJ/T 11363-2006 标准规定的限量要求。</p> <p>备注：此产品所标示之环保使用期限，系指在一般正常使用状况下。</p>						

## China RoHS Requirement (EN)

Poisonous or Hazardous Substances or Elements in Products

AAEON Main Board/ Daughter Board/ Backplane

Component	Poisonous or Hazardous Substances or Elements					
	Lead (Pb)	Mercury (Hg)	Cadmium (Cd)	Hexavalent Chromium (Cr(VI))	Polybrominated Biphenyls (PBB)	Polybrominated Diphenyl Ethers (PBDE)
PCB & Other Components	X	○	○	○	○	○
Wires & Connectors for External Connections	X	○	○	○	○	○
<p>O: The quantity of poisonous or hazardous substances or elements found in each of the component's parts is below the SJ/T 11363-2006-stipulated requirement.</p> <p>X: The quantity of poisonous or hazardous substances or elements found in at least one of the component's parts is beyond the SJ/T 11363-2006-stipulated requirement.</p> <p><b>Note:</b> The Environment Friendly Use Period as labeled on this product is applicable under normal usage only</p>						

## Table of Contents

---

<b>Chapter 1 - Product Specifications</b> .....	<b>1</b>
1.1 Specifications .....	2
<b>Chapter 2 – Hardware Information</b> .....	<b>4</b>
2.1 Dimensions .....	5
2.1.1 Module dimensions.....	5
2.1.2 With IO bracket.....	7
2.1.3 With Thermal Option .....	8
2.2 Jumpers and Connectors.....	9
2.3 List of Connectors.....	10
2.3.1 LAN (RJ-45) Port (CN2) .....	11
2.3.2 M.2 Key-E Slot (2230) (CN3).....	12
2.3.3 USB 3.0 Ports (CN4) .....	15
2.3.4 SPI Debug Port (CN8).....	16
2.3.5 Battery (CN29).....	16
2.3.6 LPC Port (CN31).....	17
2.3.7 CPU FAN (FAN) .....	18
2.3.8 SDM Gold Finger (GF1) .....	18
2.5 Function Block.....	23
2.6 Electrical Specifications for I/O Ports.....	23
<b>Chapter 3 - AMI BIOS Setup</b> .....	<b>24</b>
3.1 System Test and Initialization .....	25
3.2 AMI BIOS Setup .....	26
3.3 Setup submenu: Main .....	27
3.4 Setup submenu: Advanced .....	28
3.4.1 Advanced: CPU Configuration.....	29
3.4.2 Advanced: USB Configuration .....	30

3.4.3	Advanced: On-Module Features .....	31
3.4.4	Advanced: SIO Configuration .....	32
3.4.4.1	SIO Configuration: Serial Port Configuration .....	33
3.4.5	Advanced: SerialIO Configuration.....	34
3.4.6	Advanced: Power Management .....	35
3.4.7	Advanced: On-Module H/W Monitor .....	36
3.4.7.1	On-Module H/W Monitor: Fan 1 Mode Configuration.....	37
3.4.8	Advanced: Trusted Computing .....	40
3.4.9	Advanced: Firmware Update Configuration .....	42
3.4.10	Advanced: SCS Configuration.....	43
3.5	Setup submenu: Chipset.....	44
3.5.1	Chipset: System Agent (SA) Configuration .....	45
3.5.1.1	SA: Graphics Configuration .....	46
3.5.2	Chipset: PCH-IO Configuration .....	47
3.6	Setup submenu: Security .....	49
3.6.1	Security: Secure Boot .....	50
3.6.1.1	Secure Boot: Key Management .....	51
3.7	Setup submenu: Boot.....	54
3.7.1	Boot: BBS Priorities .....	55
3.8	Setup submenu: Save & Exit .....	56
<b>Chapter 4 – Drivers Installation.....</b>		<b>57</b>
4.1	Driver Download and Installation.....	58
<b>Appendix A - Watchdog Timer Programming.....</b>		<b>60</b>
A.1	Watchdog Timer Initial Program .....	61
<b>Appendix B - I/O Information .....</b>		<b>66</b>
B.1	I/O Address Map .....	67
B.2	Memory Address Map .....	68
B.3	IRQ Mapping Chart.....	69

Appendix C – Mating Connectors and Cables..... 70

    C.1 List of Mating Connectors and Cables.....71

# Chapter 1

---

Product Specifications

## 1.1 Specifications

---

### System

Form Factor	Intel® SDM-S Module
CPU	7th Generation Intel® Core™ i7-7600U/ i5-7300U/ i3-7100U/ Celeron® 3965U SoC
CPU Frequency	Up to 3.9 Ghz
Chipset	7th Generation Intel® Core™ i7-7600U/ i5-7300U/ i3-7100U/ Celeron® 3965U SoC
Memory Type	Onboard DDR4
Max. Memory Capacity	Up to 8GB
BIOS	AMI BIOS
Wake On LAN	Yes
Watchdog Timer	255 Levels
Power Requirement	12V DC from the Docking Board through the Edge Connector
Power Supply Type	AT/ATX
Power Consumption (Typical)	Intel® Core™ i7-7600U, DDR4 4G, 64G eMMC, 2.4A @ 12V
Dimension (L x W x H)	100mm x 60mm x 20mm
Operating Temperature	0~55 degree
Storage Temperature	-40°F ~ 176°F (-40°C ~ 80°C)

## System

Operating Humidity	0% ~ 90% relative humidity, non-condensing
MTBF (Hours)	TBD
Certification	CE/FCC

## Display

Controller	7th Generation Intel® Core™ i7-7600U/ i5-7300U/ i3-7100U/ Celeron® 3965U SoC
Video Output	1x HDMI 1.4 (through Edge connector) 1x DP1.2 (through Edge connector)
Audio	Through HDMI DP by edge connector

## I/O

Ethernet	Intel I211, RJ45 x 1
USB Port	USB 3.0 x 2
Storage	eMMC 32/64/128G
Expansion Slot	M.2 2230 (E-Key)



# Chapter 2

---

## Hardware Information

## 2.1 Dimensions

### 2.1.1 Module dimensions

#### Component Side

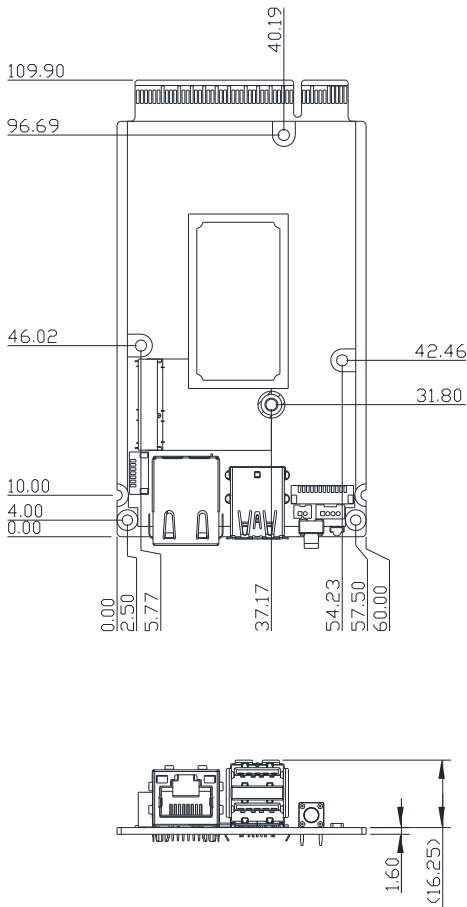

### Solder Side

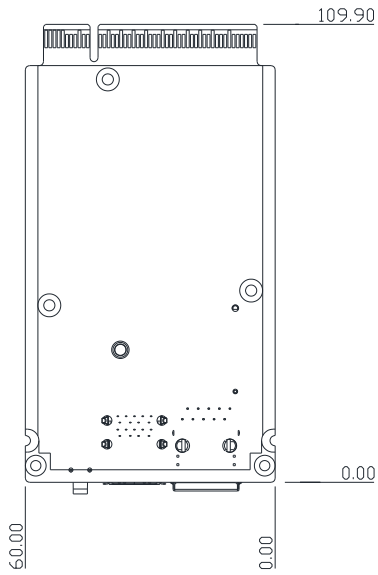

## 2.1.2 With IO bracket

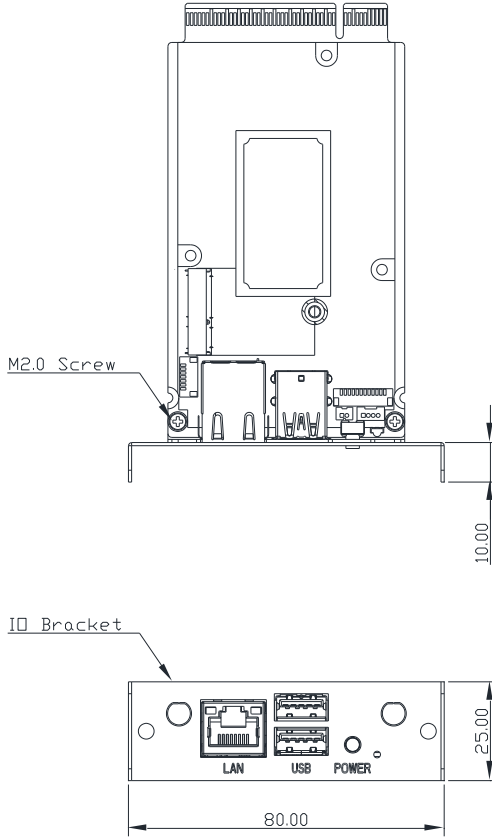

## 2.1.3 With Thermal Option

Thermal Option  
ASDM-S-KBU-FAN01

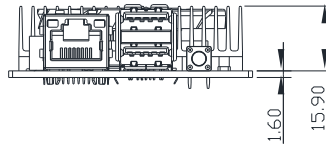
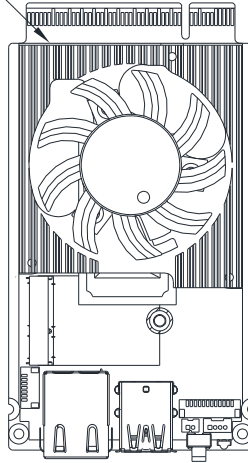

## 2.2 Jumpers and Connectors

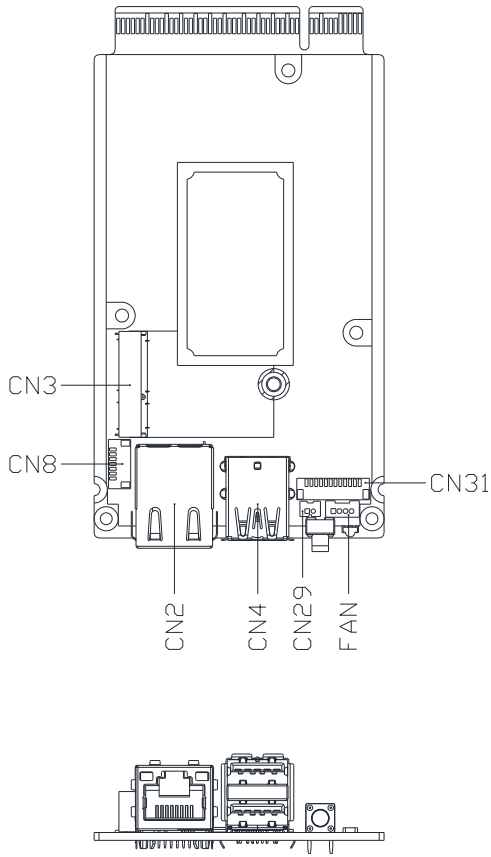

## 2.3 List of Connectors

---

The ASDM-S-KBU features a number of connectors and switches allowing for configuration and connection with external devices such as hard disk drives or a keyboard.

Label	Function
CN2	LAN (RJ-45) Port
CN3	M.2 Key-E Slot (2230)
CN4	USB 3.0 Ports
CN8	SPI Debug Port
CN29	Battery
CN31	LPC Port
FAN	CPU FAN
GF1	SDM Gold finger
SW2	Power Button

### 2.3.1 LAN (RJ-45) Port (CN2)

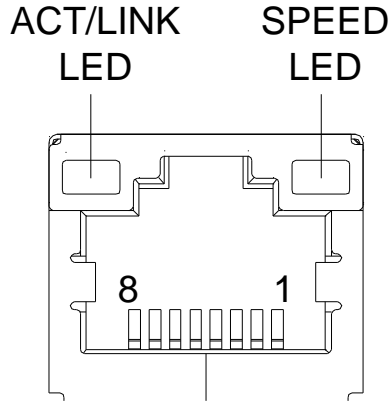

Pin	Pin Name	Signal Type	Signal Level
1	MDI0+	DIFF	
2	MDI0-	DIFF	
3	MDI1+	DIFF	
4	MDI2+	DIFF	
5	MDI2-	DIFF	
6	MDI1-	DIFF	
7	MDI3+	DIFF	
8	MDI3-	DIFF	



### 2.3.2 M.2 Key-E Slot (2230) (CN3)

Pin	Pin Name	Signal Type	Signal Level
1	GND	GND	
2	+3.3VSB	PWR	+3.3V
3	USB_D+	DIFF	
4	+3.3VSB	PWR	+3.3V
5	USB_D-	DIFF	
6	NC		
7	GND	GND	
8	NC		
9	NC		
10	NC		
11	NC		
12	NC		
13	NC		
14	NC		
15	NC		
16	NC		
17	NC		
18	NC		
19	NC		
20	NC		
21	NC		
22	NC		
23	NC		
32	NC		
33	GND	GND	

Pin	Pin Name	Signal Type	Signal Level
34	NC		
35	PCIE_TX+	DIFF	
36	NC		
37	PCIE_TX-	DIFF	
38	NC		
39	GND	GND	
40	NC		
41	PCIE_RX+	DIFF	
42	NC		
43	PCIE_RX-	DIFF	
44	NC		
45	GND	GND	
46	NC		
47	PCIE_REF_CLK+	DIFF	
48	NC		
49	PCIE_REF_CLK-	DIFF	
50	NC		
51	GND	GND	
52	PCIE_RST#	OUT	+3.3V
53	PCIE_CLK_REQ#	IN	+3.3V
54	W_DISABLE2#	OUT	+3.3V
55	PCIE_WAKE#	IN	+3.3V
56	W_DISABLE1#	OUT	+3.3V
57	GND	GND	
58	NC		
59	NC		
60	NC		

Pin	Pin Name	Signal Type	Signal Level
61	NC		
62	NC		
63	GND	GND	
64	NC		
65	NC		
66	+3.3VSB	PWR	+3.3V
67	NC		
68	NC		
69	GND	GND	
70	NC		
71	NC		
72	+3.3VSB	PWR	+3.3V
73	NC		
74	+3.3VSB	PWR	+3.3V
75	GND	GND	

### 2.3.3 USB 3.0 Ports (CN4)

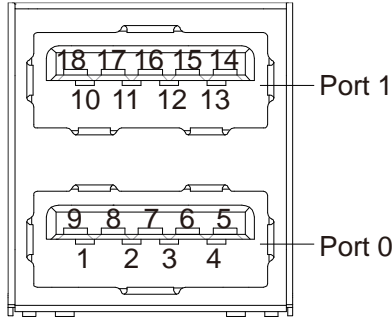

Pin	Pin Name	Signal Type	Signal Level
1	+5VSB	PWR	+5V
2	USB0_D-	DIFF	
3	USB0_D+	DIFF	
4	GND	GND	
5	USB0_SSRX-	DIFF	
6	USB0_SSRX+	DIFF	
7	GND	GND	
8	USB0_SSTX-	DIFF	
9	USB0_SSTX+	DIFF	
10	+5VSB	PWR	+5V
11	USB1_D-	DIFF	
12	USB1_D+	DIFF	
13	GND	GND	
14	USB1_SSRX-	DIFF	
15	USB1_SSRX+	DIFF	
16	GND	GND	
17	USB1_SSTX-	DIFF	
18	USB1_SSTX+	DIFF	

### 2.3.4 SPI Debug Port (CN8)

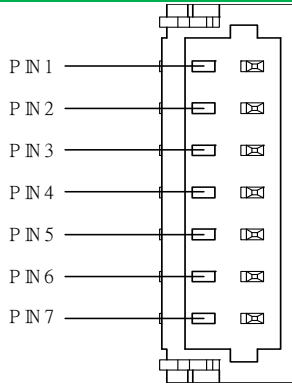

Pin	Pin Name	Signal Type	Signal Level
1	SPI_MISO	OUT	
2	GND	GND	
3	SPI_CLK	IN	
4	+3.3VSB	PWR	+3.3V
5	SPI_MOSI	IN	
6	SPI_CS	IN	
7	NC		

### 2.3.5 Battery (CN29)

Pin	Pin Name	Signal Type	Signal Level
1	+3.3V	PWR	+3.3V
2	GND	GND	

### 2.3.6 LPC Port (CN31)

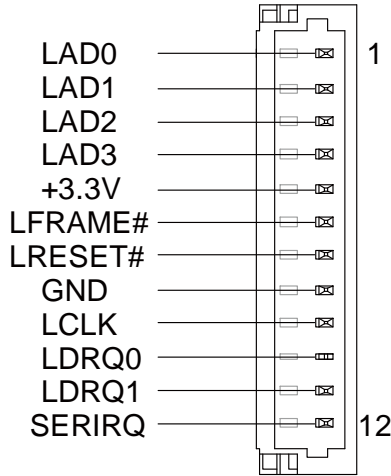

Pin	Pin Name	Signal Type	Signal Level
1	LAD0	I/O	+3.3V
2	LAD1	I/O	+3.3V
3	LAD2	I/O	+3.3V
4	LAD3	I/O	+3.3V
5	+3.3V	PWR	+3.3V
6	LFRAME#	IN	
7	LRESET#	OUT	+3.3V
8	GND	GND	
9	LCLK	OUT	
10	N.C		
11	N.C		
12	N.C		

### 2.3.7 CPU FAN (FAN)

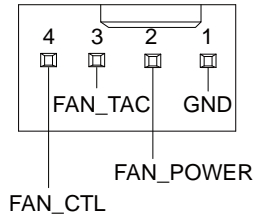

Pin	Pin Name	Signal Type	Signal Level
1	GND	GND	
2	FAN_POWER	PWR	+12V
3	FAN_TAC	IN	
4	FAN_CTL	OUT	

### 2.3.8 SDM Gold Finger (GF1)

Pin	Pin Name	Signal Type	Signal Level
A1	+12V	PWR	+12V
A2	+12V	PWR	+12V
A3	+12V	PWR	+12V
A4	GND	GND	
A5	GND	GND	
A6	PWRGD#	OUT	+3.3V
A7	SLP_S4	OUT	+3.3V
A8	SDM_DET#	OUT	
A9	NC		
A10	I2C0_SDA	I/O	+3.3V
A11	I2C0_SCL	OUT	+3.3V

Pin	Pin Name	Signal Type	Signal Level
A12	GSPI_CLK	OUT	+3.3V
A13	GSPI_CS0#	OUT	+3.3V
A14	GND	GND	
A15	PCIE_TX+	DIFF	
A16	PCIE_TX-	DIFF	
A17	GND	GND	
A18	PCIE_RX+	DIFF	
A19	PCIE_RX-	DIFF	
A20	GND	GND	
A21	PCIE_REF_CLK+	DIFF	
A22	PCIE_REF_CLK-	DIFF	
A23	GND	GND	
A24	PCIE_WAKE#	IN	+3.3V
A25	PCIE_CLK_REQ#	IN	+3.3V
A26	PCIE_RST#	OUT	+3.3V
A27	GND	GND	
A28	TMDS_CLK-	DIFF	
A29	TMDS_CLK+	DIFF	
A30	GND	GND	
A31	TMDS0-	DIFF	
A32	TMDS0+	DIFF	
A33	GND	GND	
A34	TMDS1-	DIFF	
A35	TMDS1+	DIFF	
A36	GND	GND	
A37	TMDS2-	DIFF	
A38	TMDS2+	DIFF	



Pin	Pin Name	Signal Type	Signal Level
A39	GND	GND	
A40	DDC_DATA	I/O	+3.3V
A41	DDC_CLK	OUT	+3.3V
A42	TMDS_HPD	IN	
A43	GND	GND	
A44	NC		
A45	NC		
A46	NC		
A47	NC		
A48	NC		
A49	NC		
B1	+12V	PWR	+12V
B2	+12V	PWR	+12V
B3	+3VSB	PWR	+3.3V
B4	GND	GND	
B5	GND	GND	
B6	PWRBTN#	IN	
B7	RESET#	IN	
B8	SYSFAN#	IN	
B9	GND	GND	
B10	I2C1_SDA	I/O	+3.3V
B11	I2C1_SCL	OUT	+3.3V
B12	GSPI_MOSI	OUT	+3.3V
B13	GSPI_MISO	IN	+3.3V
B14	GND	GND	
B15	UART_TXD	OUT	+3.3V
B16	UART_RXD	IN	+3.3V

Pin	Pin Name	Signal Type	Signal Level
B17	GND	GND	
B18	USB2_SSTX+	DIFF	
B19	USB2_SSTX-	DIFF	
B20	GND	GND	
B21	USB2_SSRX+	DIFF	
B22	USB2_SSRX-	DIFF	
B23	GND	GND	
B24	USB_D+	DIFF	
B25	USB_D-	DIFF	
B26	GND	GND	
B27	USB_OC#	IN	
B28	GND	GND	
B29	DP3-	DIFF	
B30	DP3+	DIFF	
B31	GND	GND	
B32	DP2-	DIFF	
B33	DP2+	DIFF	
B34	GND	GND	
B35	DP1-	DIFF	
B36	DP1+	DIFF	
B37	GND	GND	
B38	DP0-	DIFF	
B39	DP0+	DIFF	
B40	GND	GND	
B41	DP_AUX-	DIFF	
B42	DP_AUX+	DIFF	
B43	DP_HPD	IN	

Pin	Pin Name	Signal Type	Signal Level
B44	GND	GND	
B45	NC		
B46	NC		
B47	NC		
B48	NC		
B49	NC		

## 2.5 Function Block

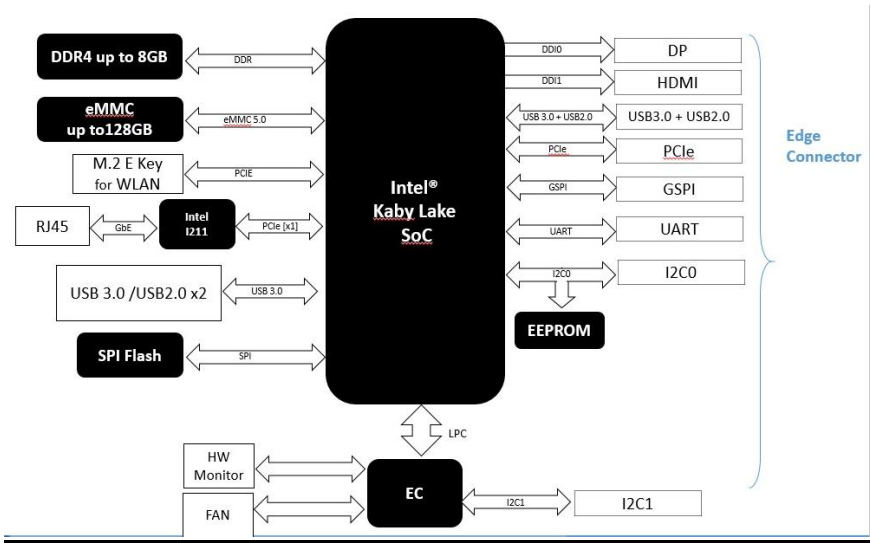

## 2.6 Electrical Specifications for I/O Ports

I/O	Reference	Signal	Output
M.2 Key-E (2230)	CN3	+3.3VSB	+3.3V/2A
USB 3.0 Ports	CN4	+5VSB	+5V/1A (per channel)
LPC Port	CN31	+3.3V	+3.3V/0.5A
CPU FAN	FAN	+12V	+12V/0.5A

# Chapter 3

---

## AMI BIOS Setup

## 3.1 System Test and Initialization

---

The ASDM-S-KBU module uses certain routines to perform testing and initialization during the boot up sequence. If an error, fatal or non-fatal, is encountered, the module will output a few short beeps or display an error message. The module can usually continue the boot up sequence with non-fatal errors.

The system configuration verification routines check the current system configuration against the values stored in the CMOS memory and BIOS NVRAM. If a system configuration is not found or an error is detected, the module will load the default configuration and reboot automatically.

There are three situations in which you will need to setup system configuration:

1. You are starting your system for the first time
2. You have changed the hardware attached to your system
3. The CMOS memory has lost power and the configuration information has been erased.

The ASDM-S-KBU CMOS memory has an integral lithium battery backup for data retention. However, you will need to replace the battery unit when it runs down.

## 3.2 AMI BIOS Setup

---

The AMI BIOS ROM has a pre-installed Setup program that allows users to modify basic system configurations. These configurations are stored in the battery-backed CMOS RAM and BIOS NVRAM so the information is retained when power is turned off.

To enter BIOS Setup, press <Del> or <F2> immediately while your computer is powering up.

The following BIOS menus and their functions are listed below.

**Main** – Date and time can be set here. Press <Tab> to switch between elements

**Advanced** – Enable/ disable boot option for legacy network devices

**Chipset** – For hosting bridge parameters

**Security** – The setup administrator password can be set here

**Boot** – Enable/ disable Quiet Boot option

**Save & Exit** – Save your changes and exit the program

### 3.3 Setup submenu: Main

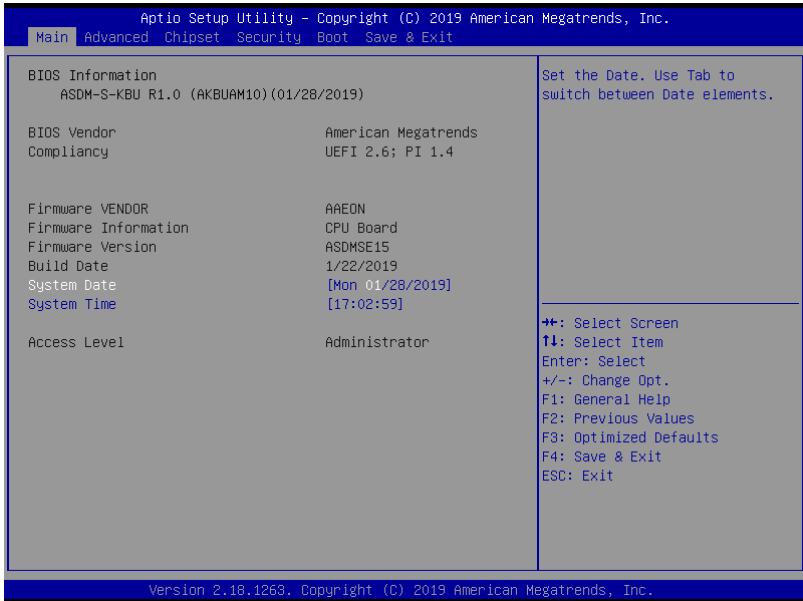



### 3.4 Setup submenu: Advanced

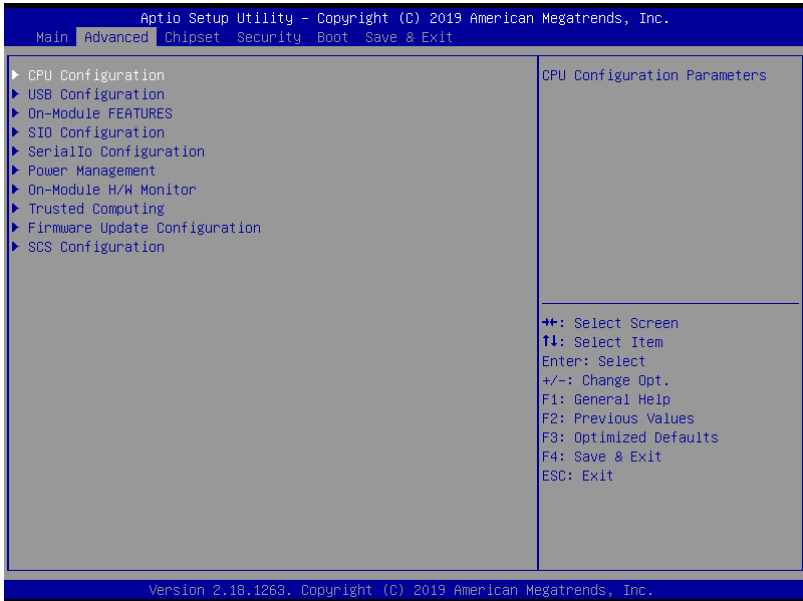

### 3.4.1 Advanced: CPU Configuration



Options Summary		
Hyper-Threading	Disabled	
	Enabled	Optimal Default, Failsafe Default
Enabled for Windows XP and Linux (OS optimized for Hyper-Threading Technology) and Disabled for other OS (OS not optimized for Hyper-Threading Technology).		
Intel (VMX) Virtualization Technology	Disabled	
	Enabled	Optimal Default, Failsafe Default
When enabled, a VMM can utilize the additional hardware capabilities provided by Vanderpool Technology.		
Intel® SpeedStep™	Disabled	
	Enabled	Optimal Default, Failsafe Default
Allows more than two frequency ranges to be supported.		

### 3.4.2 Advanced: USB Configuration

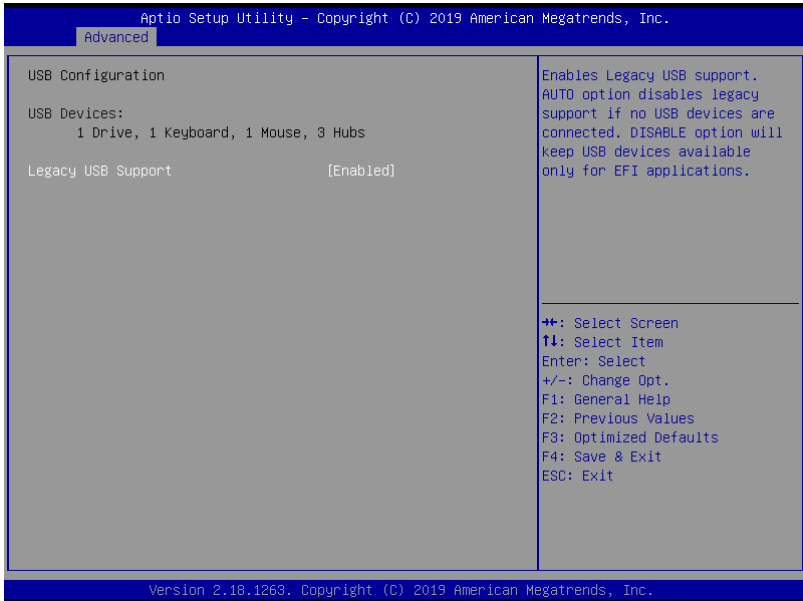

Options Summary		
Legacy USB Support	Enabled	Optimal Default, Failsafe Default
	Disabled	
	Auto	
Enables Legacy USB Support. AUTO option disables legacy support if no USB devices are connected. DISABLE option will keep USB device available only for EFI applications.		

### 3.4.3 Advanced: On-Module Features

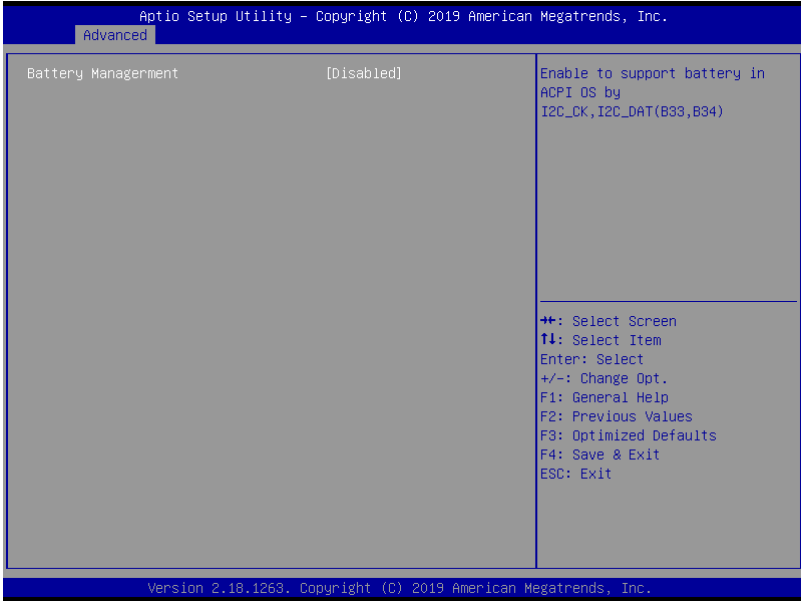

Options Summary		
Battery Management	Disabled	Optimal Default, Failsafe Default
	One Battery	
Enable to support battery in ACPI OS by I2C_CK,I2C_DAT(B33,B34)		

### 3.4.4 Advanced: SIO Configuration

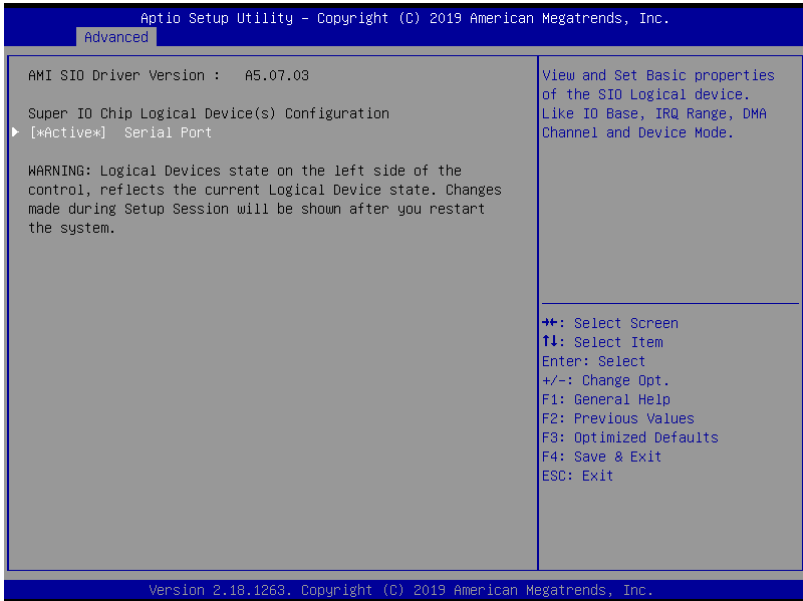

### 3.4.4.1 SIO Configuration: Serial Port Configuration

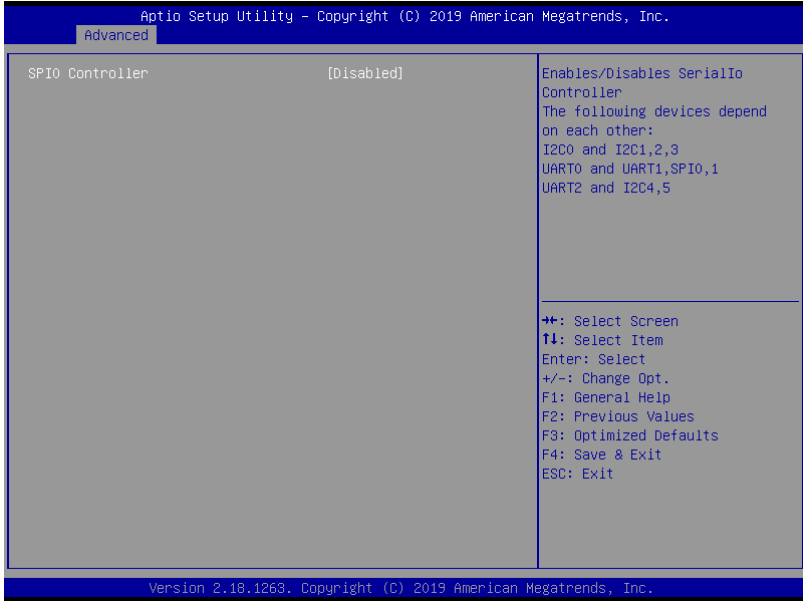

Options Summary		
Use This Device	Disable	
	Enable	Optimal Default, Failsafe Default
Enable or Disable this Logical Device.		
Possible:	Use Automatic Settings	Optimal Default, Failsafe Default
	IO=2D8; IRQ=11; DMA;	
	IO=2C8; IRQ=11; DMA;	
Allows the user to change the device resource settings. New settings will be reflected on this setup page after system restarts.		

### 3.4.5 Advanced: SerialIO Configuration

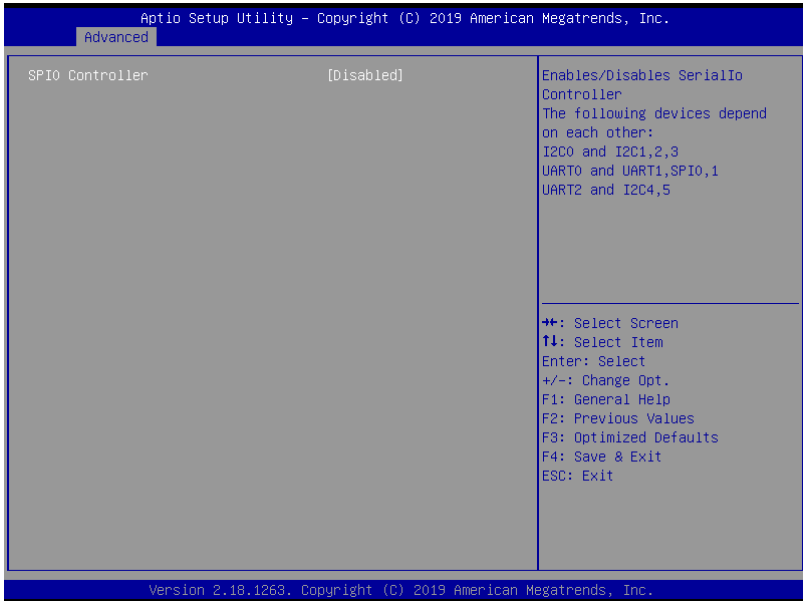

Options Summary		
SPI0 Controller	Disabled	Optimal Default, Failsafe Default
	Enabled	
Enables/Disables SerialIo Controller The following devices depend on each other: I2C0 and I2C1,2,3 UART0 and UART1,SPI0,1 UART2 and I2C4,5		

### 3.4.6 Advanced: Power Management

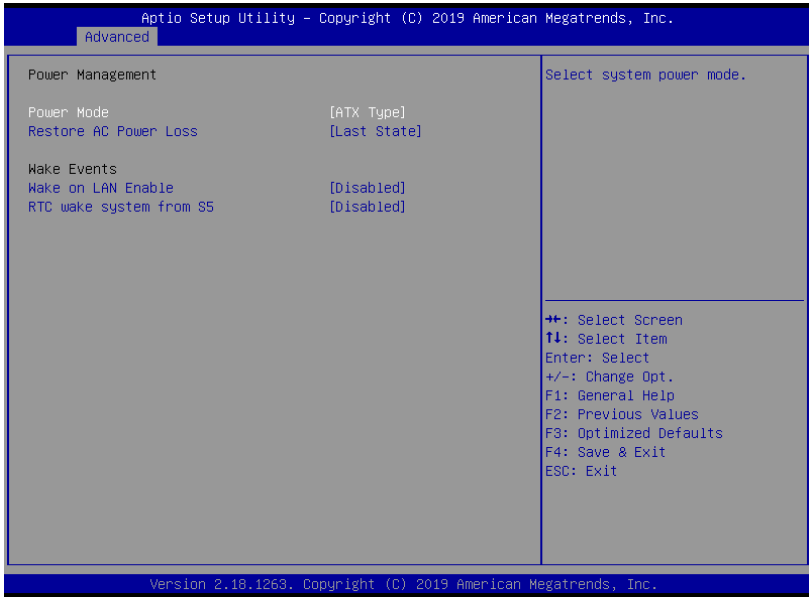

Options Summary		
Power Mode	ATX Type	Optimal Default, Failsafe Default
	AT Type	
Select system power mode.		
Restore AC Power Loss	Last State	Optimal Default, Failsafe Default
	Always On	
	Always Off	
Wake on LAN Enable	Enabled	
	Disabled	Optimal Default, Failsafe Default
Enabled/ Disabled integrated LAN to wake the system.		
RTC wake system from S5	Disabled	Optimal Default, Failsafe Default
	Fixed Time	
Fixed Time: System will wake on the hr::min::sec specified.		
Dynamic time: System will wake on the current time + Increase minute(s)		



### 3.4.7 Advanced: On-Module H/W Monitor

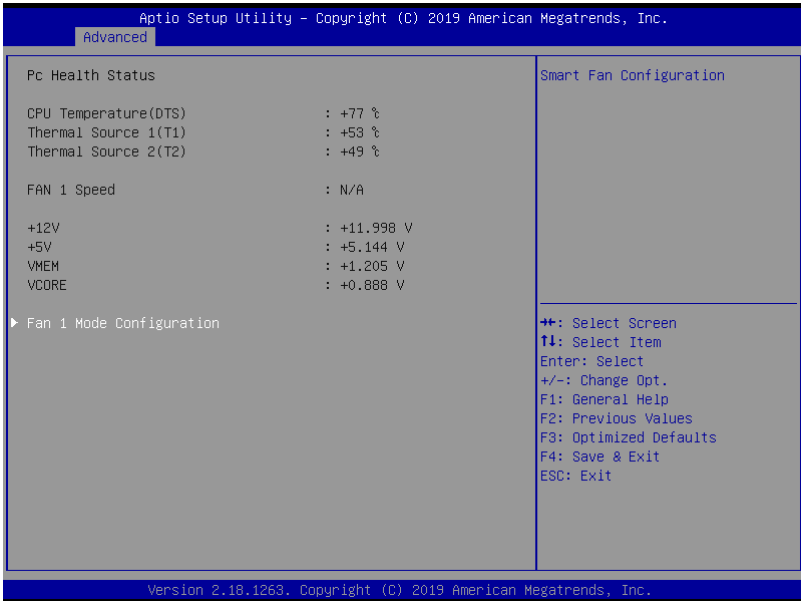

### 3.4.7.1 On-Module H/W Monitor: Fan 1 Mode Configuration

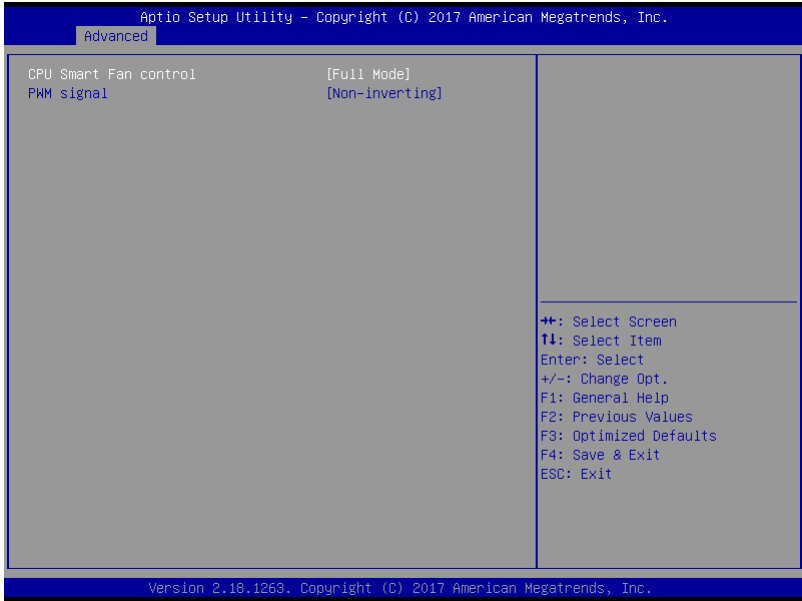

Options Summary		
CPU Smart Fan Mode	Full Mode	Optimal Default, Failsafe Default
	Manual Mode by PWM	
	Auto Mode by PWM	
Smart Fan Mode Select		
PWM signal	Non-inverting	Optimal Default, Failsafe Default
	Inverting	
Select output PWM of inverting or non-uninverting signal		

## CPU Smart Fan Mode: Manual Mode by PWM

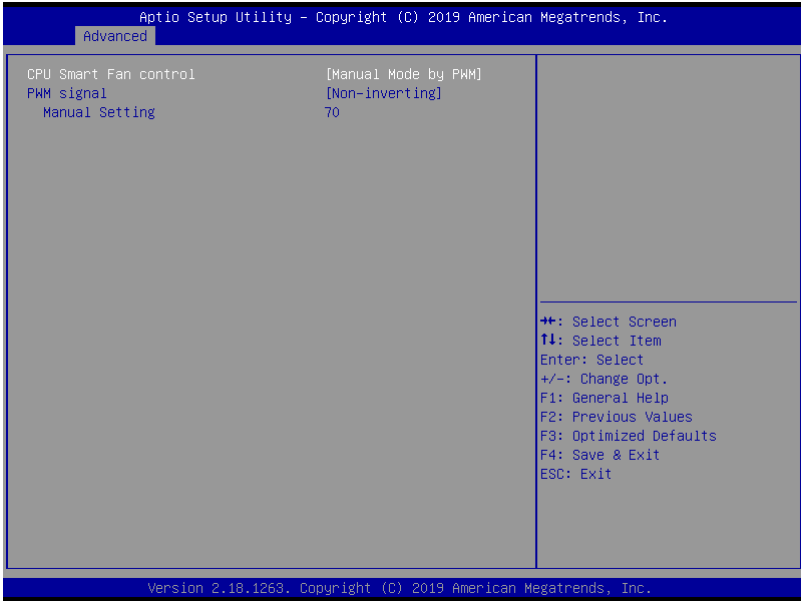

## Options Summary

Manual Setting	70	Optimal Default, Failsafe Default
----------------	----	-----------------------------------

Set Fan at fixed Duty-Cycle Min=. Max=100 Please input Dec number:

## CPU Smart Fan Mode: Auto Mode by PWM

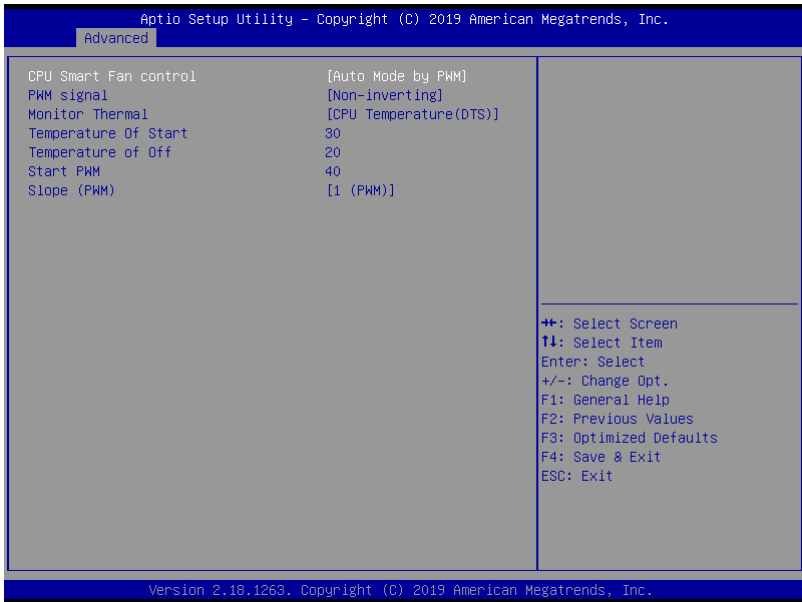

Options Summary		
Monitor Thermal	CPU Temperature(DTS)	Optimal Default, Failsafe Default
	Thermal Source 1(T1)	
	Thermal Source 2(T2)	
Select monitor thermal source		
Temperature of Start	30	Optimal Default, Failsafe Default
Temperature Of Start		
Temperature Of Off	20	Optimal Default, Failsafe Default
Temperature Of Off		
Start PWM	40	Optimal Default, Failsafe Default
Start PWM		
Slope (PWM)	0 (PWM)	
	1 (PWM)	Optimal Default, Failsafe Default
	2 (PWM)	
	4 (PWM)	
	8 (PWM)	
	16 (PWM)	
	32 (PWM)	
	64 (PWM)	
Slope (PWM)		

### 3.4.8 Advanced: Trusted Computing

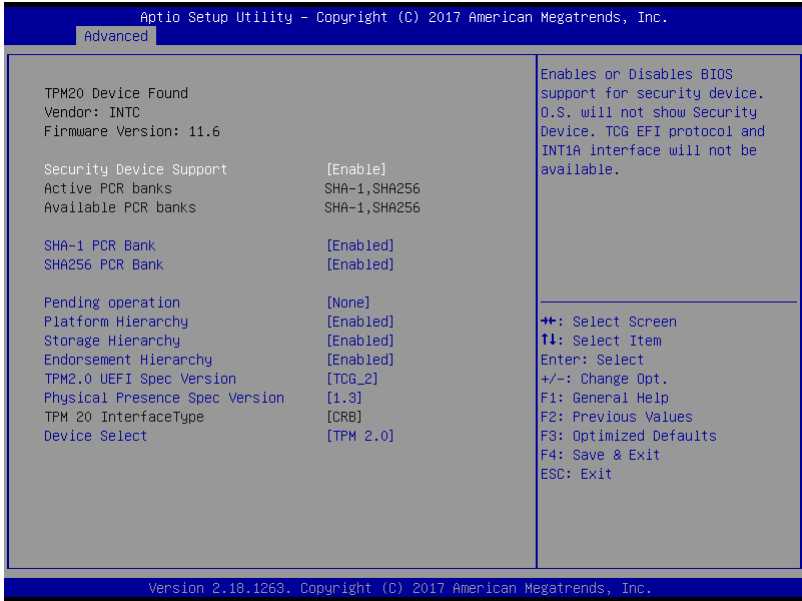

Options Summary		
Security Device Support	Disable	
	Enable	Optimal Default, Failsafe Default
Enables or Disables BIOS support for security device. O.S. will not show Security Device. TCG EFI protocol and INT1A interface will not be available.		
SHA-1 PCR Bank	Disable	
	Enable	Optimal Default, Failsafe Default
Enable or Disable SHA-1 PCR Bank		
SHA256 PCR Bank	Disable	
	Enable	Optimal Default, Failsafe Default
Enable or Disable SHA256 PCR Bank		
Pending operation	None	Optimal Default, Failsafe Default
	TPM Clear	
Schedule an Operation for the Security Device. NOTE: Your Computer will reboot during restart in order to change state of Security Device.		

Options Summary		
<b>Platform Hierarchy</b>	Disable	
	Enable	Optimal Default, Failsafe Default
Enable or Disable Platform Hierarchy		
<b>Storage Hierarchy</b>	Disable	
	Enable	Optimal Default, Failsafe Default
Enable or Disable Storage Hierarchy		
<b>Endorsement Hierarchy</b>	Disable	
	Enable	Optimal Default, Failsafe Default
Enable or Disable Endorsement Hierarchy		
<b>TPM2.0 UEFI Spec Version</b>	TCG_2	Optimal Default, Failsafe Default
	TCG_1_2	
Select the TCG2 Spec Version Support, TCG_1_2: the Compatible mode for Win8/Win10, TCG_2: Support new TCG2 protocol and event format for Win10 or later		
<b>Physical Presence Spec Version</b>	1.2	
	1.3	Optimal Default, Failsafe Default
Select to Tell O.S. to support PPI Spec Version 1.2 or 1.3. Note some HCK tests might not support 1.3.		
<b>Device Select</b>	TPM 2.0	Optimal Default, Failsafe Default
TPM 1.2 will restrict support to TPM 1.2 device, TPM 2.0 will restrict support to TPM 2.0 devices, Auto will support both with the default set to TPM 2.0 devices if not found, TPM 1.2 device will be enumerated.		

### 3.4.9 Advanced: Firmware Update Configuration



Options Summary		
Me FW Image	Disable	Optimal Default, Failsafe Default
Re-Flash	Enable	
Enable/ Disable Me FW Image Re-Flash functinn.		

### 3.4.10 Advanced: SCS Configuration

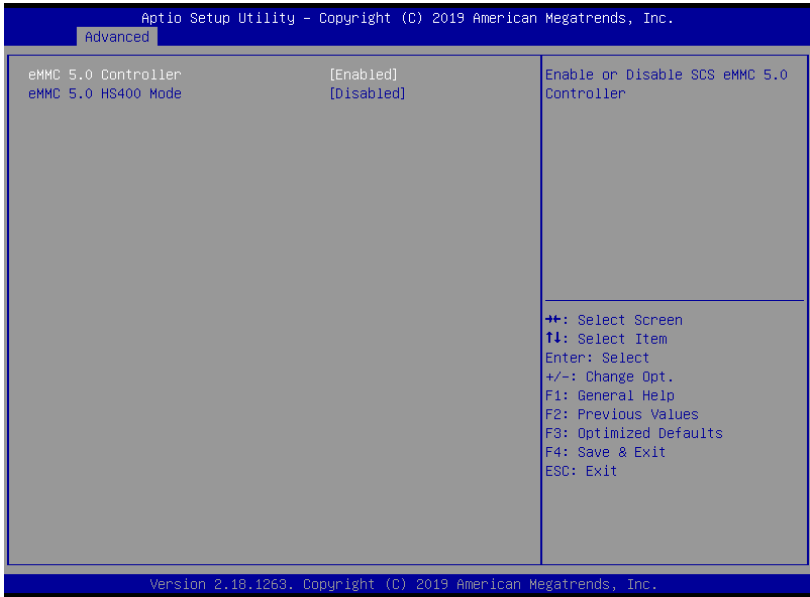

Options Summary		
Emmc 5.0 Controller	Disable	
	Enable	Optimal Default, Failsafe Default
Enable or Disable Emmc 5.0 Controller		
Emmc 5.0 HS400 Mode	Disable	Optimal Default, Failsafe Default
	Enable	
Enable or Disable Emmc 5.0 HS400 Mode		



### 3.5 Setup submenu: Chipset

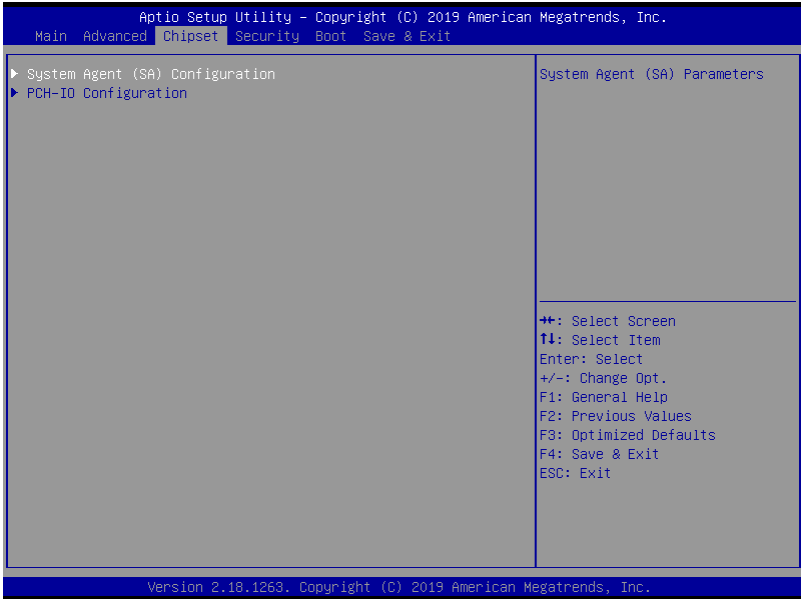

### 3.5.1 Chipset: System Agent (SA) Configuration

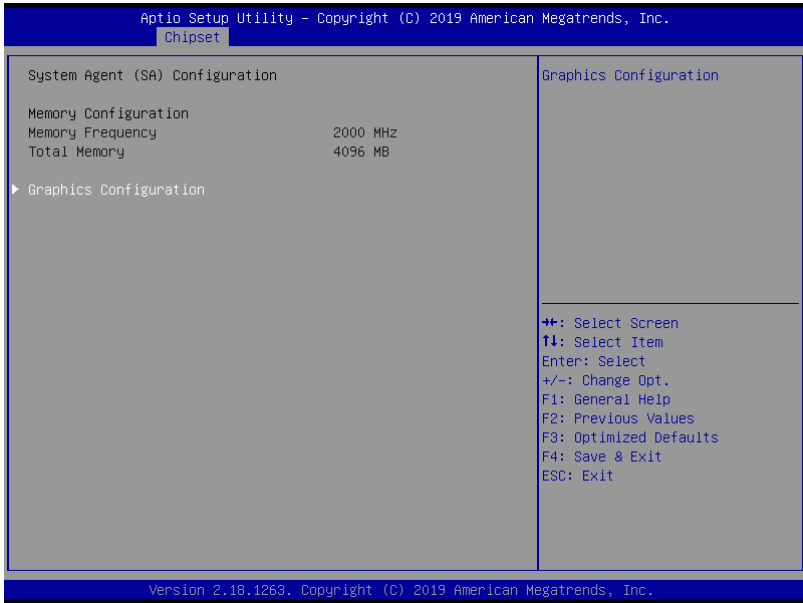

### 3.5.1.1 SA: Graphics Configuration

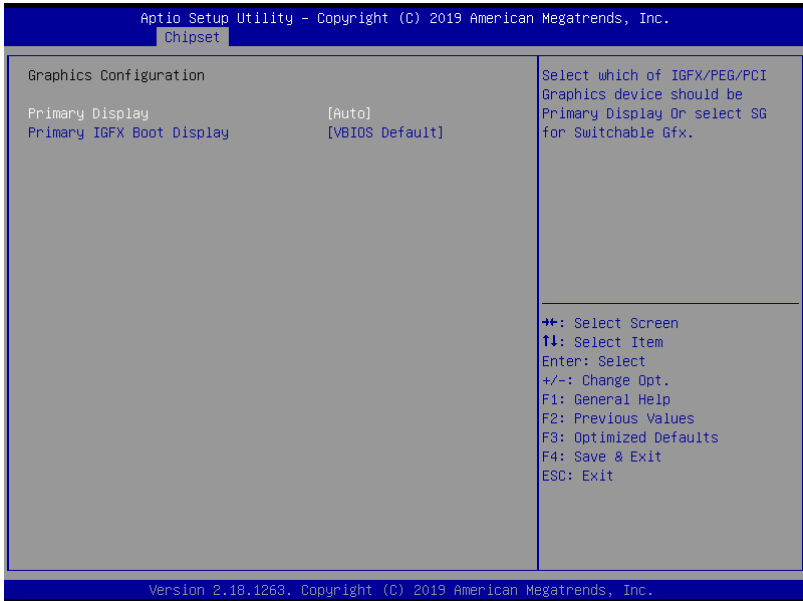

Options Summary		
Primary Display	Auto	Optimal Default, Failsafe Default
	IGFX	
	PEG	
Select which of IGFX/PEG/PCI Graphics device should be Primary Display Or select SG for Switchable Gfx.		
Primary IGFX Boot Display	VBIOS Default	Optimal Default, Failsafe Default
	Display Port	
	HDMI Port	
Select the Video Device which will be activated during POST. This has no effect if external graphics present. Secondary boot display selection will appear based on your selection. VGA modes will be supported only on primary display		

### 3.5.2 Chipset: PCH-IO Configuration

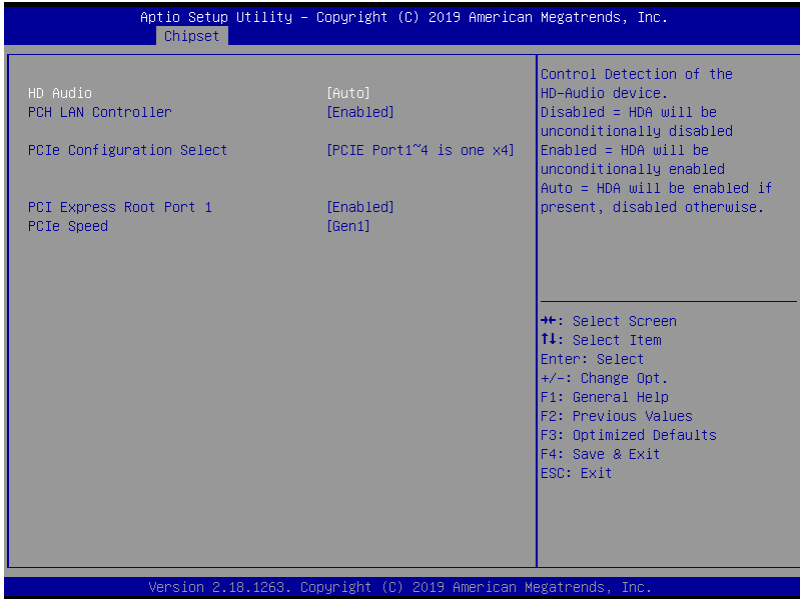

Options Summary		
HD Audio	Disabled	
	Enabled	
	Auto	Optimal Default, Failsafe Default
Control Detection of the HD-Audio device. Disabled = HDA will be unconditionally disabled Enabled = HDA will be unconditionally enabled Auto = HDA will be enabled if present, disabled otherwise.		
PCH LAN Controller	Enabled	Optimal Default, Failsafe Default
	Disabled	
Enable/Disable onboard NIC.		
PCIe Configuration Select	PCIe Port1~4 are four x1	
	PCIe Port1~4 is one x4	Optimal Default, Failsafe Default
PCIe Port1~4 Selection		
PCI Express Root Port 1	Disabled	
	Enabled	Optimal Default, Failsafe Default
Control the PCI Express Root Port.		

**Options Summary**

PCIe Speed	Auto	
	Gen1	Optimal Default, Failsafe Default
	Gen2	
	Gen3	
Comfigure PCIe Speed		

## 3.6 Setup submenu: Security

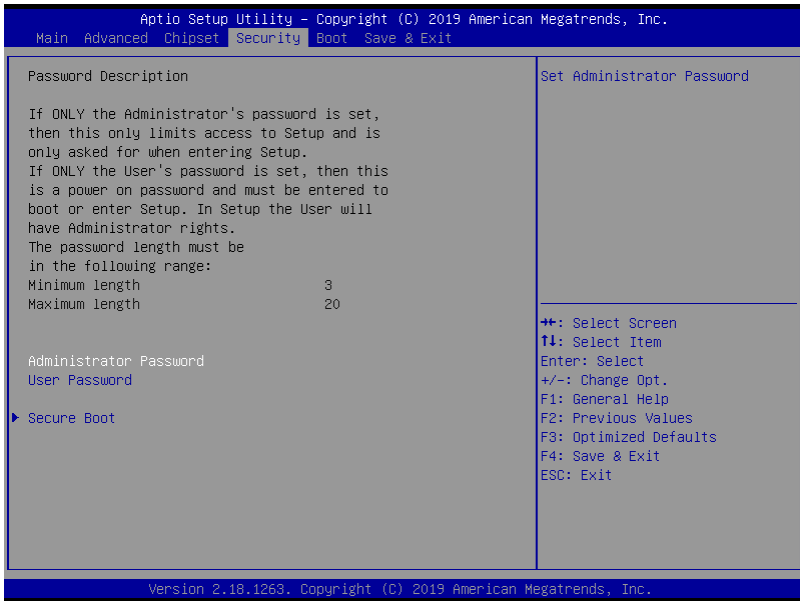

### Change User/Administrator Password

You can set an Administrator Password or User Password. An Administrator Password must be set before you can set a User Password. The password will be required during boot up, or when the user enters the Setup utility. A User Password does not provide access to many of the features in the Setup utility.

Select the password you wish to set, and press Enter. In the dialog box, enter your password (must be between 3 and 20 letters or numbers). Press Enter and retype your password to confirm. Press Enter again to set the password.

### Removing the Password

Select the password you want to remove and enter the current password. At the next dialog box press Enter to disable password protection.

### 3.6.1 Security: Secure Boot

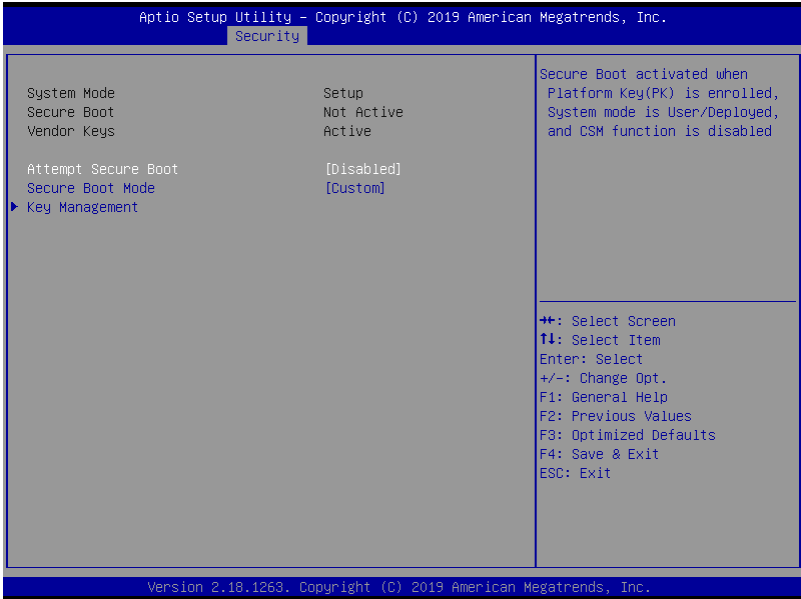

Options Summary		
<b>Attempt Secure Boot</b>	Disabled	Optimal Default, Failsafe Default
	Enabled	
Secure Boot activated when Platform Key(PK) is enrolled, System mode is User/Deployed, and CSM function is disabled		
<b>Secure Boot Mode</b>	Standard	
	Custom	Optimal Default, Failsafe Default
Secure Boot Mode selector: Standard/Custom. In Custom mode Secure Boot Variables can be configured without authentication		

### 3.6.1.1 Secure Boot: Key Management

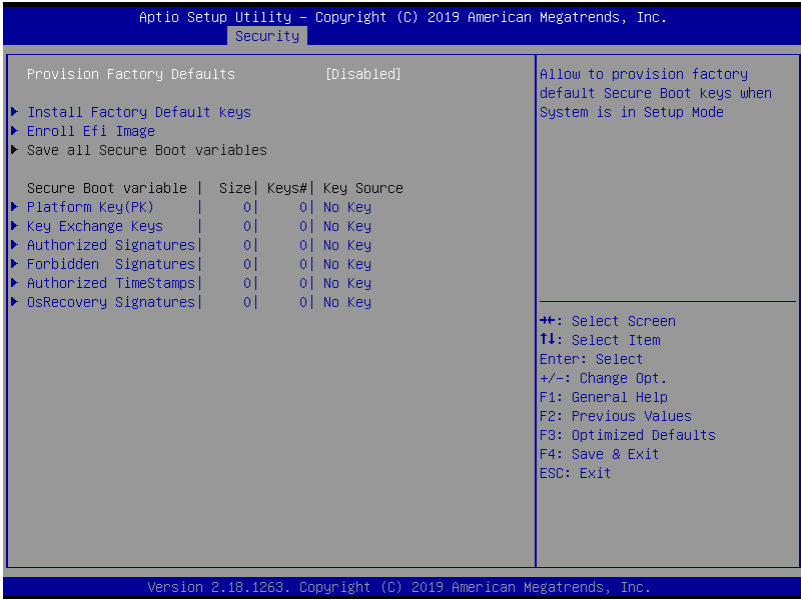

Options Summary		
Provision Factory Defaults	Disabled	Optimal Default, Failsafe Default
	Enabled	
Allow to provision factory default Secure Boot keys when System is in setup Mode		
Install Factory Default keys		
Force System to User Mode - install all Factory Default keys		
Enroll Efi Image		
Allow the image to run in Secure Boot mode.		
Enroll SHA256 hash of the binary into Authorized Signature Database (db)		

Table Continues on Next Page



## Options Summary

### Platform Key(PK)

Enroll Factory Defaults or load certificates from a file:

- 1.Public Key Certificate in:
  - a)EFI\_SIGNATURE\_LIST
  - b)EFI\_CERT\_X509 (DER encoded)
  - c)EFI\_CERT\_RSA2048 (bin)
  - d)EFI\_CERT\_SHA256,384,512
- 2.Authenticated UEFI Variable
- 3.EFI PE/COFF Image(SHA256)

#### Key Source:

Default, External, Mixed, Test

### Key Exchange Keys

Enroll Factory Defaults or load certificates from a file:

- 1.Public Key Certificate in:
  - a)EFI\_SIGNATURE\_LIST
  - b)EFI\_CERT\_X509 (DER encoded)
  - c)EFI\_CERT\_RSA2048 (bin)
  - d)EFI\_CERT\_SHA256,384,512
- 2.Authenticated UEFI Variable
- 3.EFI PE/COFF Image(SHA256)

#### Key Source:

Default, External, Mixed, Test

### Authorized Signatures

Enroll Factory Defaults or load certificates from a file:

- 1.Public Key Certificate in:
  - a)EFI\_SIGNATURE\_LIST
  - b)EFI\_CERT\_X509 (DER encoded)
  - c)EFI\_CERT\_RSA2048 (bin)
  - d)EFI\_CERT\_SHA256,384,512
- 2.Authenticated UEFI Variable
- 3.EFI PE/COFF Image(SHA256)

#### Key Source:

Default, External, Mixed, Test

*Table Continues on Next Page*

## Options Summary

### Forbidden Signatures

Enroll Factory Defaults or load certificates from a file:

- 1.Public Key Certificate in:
  - a)EFI\_SIGNATURE\_LIST
  - b)EFI\_CERT\_X509 (DER encoded)
  - c)EFI\_CERT\_RSA2048 (bin)
  - d)EFI\_CERT\_SHA256,384,512
- 2.Authenticated UEFI Variable
- 3.EFI PE/COFF Image(SHA256)

#### Key Source:

Default, External, Mixed, Test

### Authorized TimeStamps

Enroll Factory Defaults or load certificates from a file:

- 1.Public Key Certificate in:
  - a)EFI\_SIGNATURE\_LIST
  - b)EFI\_CERT\_X509 (DER encoded)
  - c)EFI\_CERT\_RSA2048 (bin)
  - d)EFI\_CERT\_SHA256,384,512
- 2.Authenticated UEFI Variable
- 3.EFI PE/COFF Image(SHA256)

#### Key Source:

Default, External, Mixed, Test

### OsRecovery Signatures

Enroll Factory Defaults or load certificates from a file:

- 1.Public Key Certificate in:
  - a)EFI\_SIGNATURE\_LIST
  - b)EFI\_CERT\_X509 (DER encoded)
  - c)EFI\_CERT\_RSA2048 (bin)
  - d)EFI\_CERT\_SHA256,384,512
- 2.Authenticated UEFI Variable
- 3.EFI PE/COFF Image(SHA256)

#### Key Source:

Default, External, Mixed, Test

### 3.7 Setup submenu: Boot

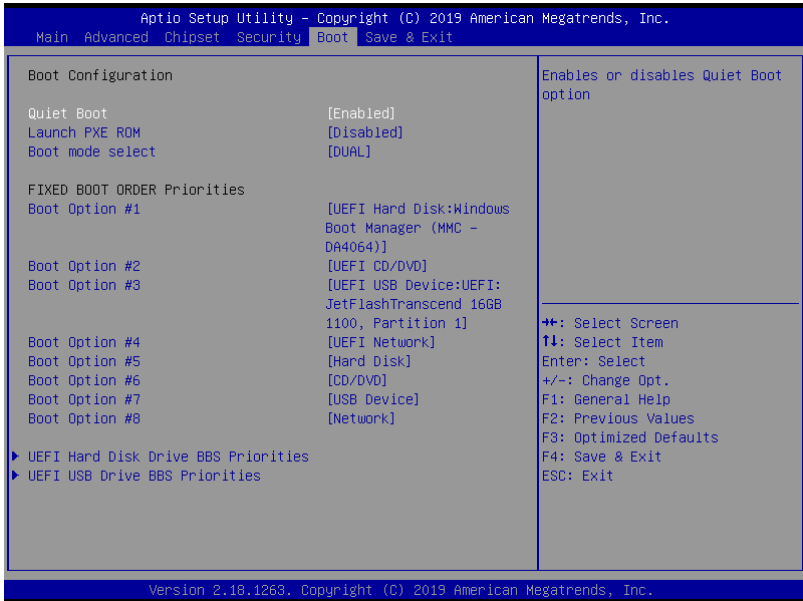

Options Summary		
Quiet Boot	Disabled	Optimal Default, Failsafe Default
	Enabled	
Enable/Disable showing boot logo.		
Launch PXE OpROM	Do not launch	Optimal Default, Failsafe Default
	UEFI	
	UEFI and Legacy	
Controls the execution of UEFI and Legacy PXE OpRom		
BIOS MODE	LEGACY	Optimal Default, Failsafe Default
	UEFI only	
	UEFI and Legacy	
Select using BIOS mode		

### 3.7.1 Boot: BBS Priorities

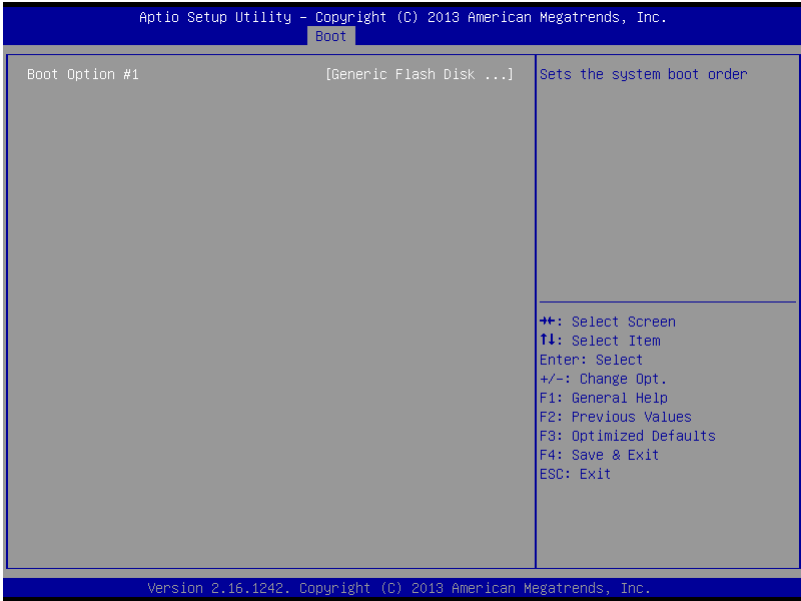

### 3.8 Setup submenu: Save & Exit

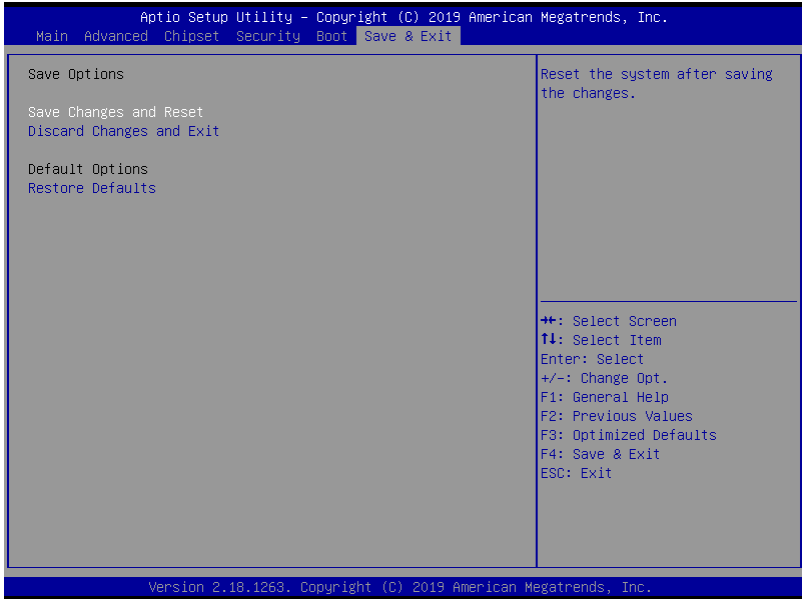

# Chapter 4

---

## Drivers Installation

## 4.1 Driver Download and Installation

---

Drivers for the ASDM-S-KBU can be downloaded from the product page on the AAEON website by following this link:

<https://www.aaeon.com/en/p/smart-display-modules-asdm-s-kbu>

Download the driver(s) you need and follow the steps below to install them.

### Step 1 – Install Chipset Drivers

1. Open the **Step 1 - CHIPSET** folder
2. Open the **SetupChipset.exe** file in the folder
3. Follow the instructions
4. Drivers will be installed automatically

### Step 2 – Install Graphics Drivers (Windows 10 only)

1. Open the **Step 2 - Graphic** folder
2. Open the **Setup.exe** file in the folder
3. Follow the instructions
4. Drivers will be installed automatically

### Step 3 – Install LAN Drivers

1. Open the **Step 3 - LAN** folder and select your OS
2. Open the **.exe** or **.tar** file in the folder
3. Follow the instructions
4. Drivers will be installed automatically

#### Step 4 – Install Audio Drivers (Windows Only)

1. Open the **Step 4 - Audio** folder
2. Open the **.exe** file in the folder
3. Follow the instructions
4. Drivers will be installed automatically

#### Step 5 – Install ME Drivers

1. Open the **Step 5 - ME** folder
2. Open the **SetupME.exe** file in the folder
3. Follow the instructions
4. Drivers will be installed automatically

#### Step 6 – Install Serial IO Drivers (Windows 10 Only)

1. Open the **Step 6 – Serial IO** folder
2. Open the **SetupSerialIO.exe** file in the folder
3. Follow the instructions
4. Drivers will be installed automatically



# Appendix A

---

## Watchdog Timer Programming

## A.1 Watchdog Timer Initial Program

**Table 1 : Embedded BRAM relative register table**

	Default Value	Note
Index	0x284(Note1)	BRAM Index Register
Data	0x285(Note2)	BRAM Data Register
Logical Device Number	0xA8(Note3)	Watch dog Logical Device Number
Function and Device Number	0x00(Note4)	Watch dog Function/Device Number

**Table 2 : Watchdog relative register table**

	Option Register	BitNum	Value	Note
Timer Counter	0x00(Note5)		(Note10)	Time of watchdog timer (0~255)
Counting Unit	0x01(Note6)	0(Note7)	0(Note11)	Select time unit. 0: second 1: minute
Watchdog RST pulse width	0x01(Note8)	[3:2](Note9)	0(Note12)	0: 20ms 1: 60ms 2: 100ms 3: 250ms

```
*****
// Embedded BRAM relative definition (Please reference to Table 1)
#define byte EcBRAMIndex //This parameter is represented from Note1
#define byte EcBRAMData //This parameter is represented from Note2
#define byte BRAMLDRReg //This parameter is represented from Note3
#define byte BRAMFnDataReg //This parameter is represented from Note4
#define void EcBRAMWriteByte(byte Offset, byte Value);
#define byte EcBRAMReadByte(byte Offset);
#define void IOWriteByte(byte Offset, byte Value);
#define byte IOReadByte(byte Offset);
// Watch Dog relative definition (Please reference to Table 2)
#define byte TimerReg //This parameter is represented from Note5
#define byte TimerVal // This parameter is represented from Note10
#define byte UnitReg //This parameter is represented from Note6
#define byte UnitBit //This parameter is represented from Note7
#define byte UnitVal //This parameter is represented from Note11
#define byte RSTReg //This parameter is represented from Note8
#define byte RSTBit //This parameter is represented from Note9
#define byte RSTVal //This parameter is represented from Note12
*****
```

```
*****
VOID Main(){
    // Procedure : AaeonWDTConfig
    // (byte)Timer : Time of WDT timer.(0x00~0xFF)
    // (boolean)Unit : Select time unit(0: second, 1: minute).
    AaeonWDTConfig();

    // Procedure : AaeonWDTEnable
    // This procedure will enable the WDT counting.
    AaeonWDTEnable();
}
*****
```

```
*****
// Procedure : AaeonWDTEnable
VOID AaeonWDTEnable 0{
    WDTEnableDisable(1);
}

// Procedure : AaeonWDTConfig
VOID AaeonWDTConfig 0{
    // Disable WDT counting
    WDTEnableDisable(0);
    // WDT relative parameter setting
    WDTParameterSetting();
}

VOID WDTEnableDisable(byte Value){
    ECBRAMWriteByte(TimerReg , Value);
}

VOID WDTParameterSetting0(){
    Byte TempByte;

    // Watchdog Timer counter setting
    ECBRAMWriteByte(TimerReg , TimerVal);
    // WDT counting unit setting
    TempByte = ECBRAMReadByte(UnitReg);
    TempByte |= (UnitVal << UnitBit);
    ECBRAMWriteByte(UnitReg , TempByte);
    // WDT RST pulse width setting
    TempByte = ECBRAMReadByte(RSTReg);
    TempByte |= (RSTVal << RSTBit);
    ECBRAMWriteByte(RSTReg , TempByte);
}
*****
```

```

*****
VOID  ECBRAMWriteByte(byte OPReg, byte OPBit, byte Value){
    IOWriteByte(EcBRAMIndex, 0x10);
    IOWriteByte(EcBRAMData, BRAMLDNReg);
    IOWriteByte(EcBRAMIndex, 0x11);
    IOWriteByte(EcBRAMData, BRAMFnDataReg);

    IOWriteByte(EcBRAMIndex, 0x13 + OPReg);
    IOWriteByte(EcBRAMData, Value);

    IOWriteByte(EcBRAMIndex, 0x12);
    IOWriteByte(EcBRAMData, 0x30);          //Write start
}

Byte  ECBRAMReadByte(byte OPReg){
    IOWriteByte(EcBRAMIndex, 0x10);
    IOWriteByte(EcBRAMData, BRAMLDNReg);
    IOWriteByte(EcBRAMIndex, 0x11);
    IOWriteByte(EcBRAMData, BRAMFnDataReg);

    IOWriteByte(EcBRAMIndex, 0x12);
    IOWriteByte(EcBRAMData, 0x10);          //Read start

    IOWriteByte(EcBRAMIndex, 0x13 + OPReg);
    Return      IOReadByte(EcBRAMData, Value);
}
*****

```

# Appendix B

---

I/O Information

# B.1 I/O Address Map

The screenshot displays the Windows Device Manager window for a device named 'DESKTOP-JTF4Q00'. The 'Input/output (IO)' section is expanded, showing a list of hardware resources with their corresponding I/O address ranges. The list includes:





























- PCI Express Root Complex
- Multiple Programmable interrupt controllers
- Motherboard resources
- System timer
- Microsoft ACPI-Compliant Embedded Controller
- System CMOS/real time clock
- Multiple Communications Port (COM9) devices
- Intel(R) HD Graphics 620
- Mobile 6th/7th Generation Intel(R) Processor Family I/O PCI Express Root Port #3 - 9D12
- Standard SATA AHCI Controller



## B.2 Memory Address Map

▼	Memory
	[00000000A0000 - 000000000BFFFF] Intel(R) HD Graphics 620
	[00000000A0000 - 000000000BFFFF] PCI Express Root Complex
	[000000009000000 - 00000000DFFFFFFF] PCI Express Root Complex
	[00000000C000000 - 00000000CFFFFFFF] Intel(R) HD Graphics 620
	[00000000DE00000 - 00000000DEFFFFFF] Intel(R) HD Graphics 620
	[00000000DF00000 - 00000000DF01FFFF] Intel(R) I211 Gigabit Network Connection
	[00000000DF00000 - 00000000DF0FFFFF] Mobile 6th/7th Generation Intel(R) Processor Family I/O PCI Express Root Port #3 - 9D12
	[00000000DF20000 - 00000000DF23FFFF] Intel(R) I211 Gigabit Network Connection
	[00000000DF110000 - 00000000DF11FFFF] Intel(R) USB 3.0 eXtensible Host Controller - 1.0 (Microsoft)
	[00000000DF128000 - 00000000DF129FFF] Standard SATA AHCI Controller
	[00000000DF12A000 - 00000000DF12A0FF] Mobile 6th/7th Generation Intel(R) Processor Family I/O SMBUS - 9D23
	[00000000DF12B000 - 00000000DF12BFFF] Intel SD Host Controller
	[00000000DF12D000 - 00000000DF12D7FF] Standard SATA AHCI Controller
	[00000000DF12E000 - 00000000DF12E0FF] Standard SATA AHCI Controller
	[00000000DF130000 - 00000000DF130FFF] Mobile 6th/7th Generation Intel(R) Processor Family I/O Thermal subsystem - 9D31
	[00000000DFFE0000 - 00000000DFFFFFFF] Motherboard resources
	[00000000DE000000 - 00000000EFFFFFFF] Motherboard resources
	[00000000FD000000 - 00000000FDABFFFF] Motherboard resources
	[00000000FD000000 - 00000000FE7FFFFFFF] PCI Express Root Complex
	[00000000FDAC0000 - 00000000FDACFFFF] Motherboard resources
	[00000000FDAD0000 - 00000000FDADFFFF] Motherboard resources
	[00000000FDAE0000 - 00000000FDAEFFFF] Motherboard resources
	[00000000FDAF0000 - 00000000FDAFFFFF] Motherboard resources
	[00000000FDB00000 - 00000000FDBFFFFF] Motherboard resources
	[00000000FE000000 - 00000000FE01FFFF] Motherboard resources
	[00000000FE028000 - 00000000FE028FFF] Motherboard resources
	[00000000FE029000 - 00000000FE029FFF] Motherboard resources
	[00000000FE030000 - 00000000FE033FFF] High Definition Audio Controller
	[00000000FE035000 - 00000000FE035FFF] Intel(R) Serial IO UART Host Controller - 9D27
	[00000000FE036000 - 00000000FE03BFFF] Motherboard resources
	[00000000FE03C000 - 00000000FE03CFFF] Intel(R) Management Engine Interface
	[00000000FE03C000 - 00000000FE03CFFF] Intel(R) Management Engine Interface
	[00000000FE03D000 - 00000000FE3FFFFFFF] Motherboard resources
	[00000000FE400000 - 00000000FE40FFFF] High Definition Audio Controller
	[00000000FE410000 - 00000000FE7FFFFFFF] Motherboard resources
	[00000000FED00000 - 00000000FED003FF] High precision event timer
	[00000000FED10000 - 00000000FED17FFF] Motherboard resources
	[00000000FED18000 - 00000000FED18FFF] Motherboard resources
	[00000000FED19000 - 00000000FED19FFF] Motherboard resources
	[00000000FED20000 - 00000000FED3FFFF] Motherboard resources
	[00000000FED40000 - 00000000FED44FFF] Trusted Platform Module 2.0
	[00000000FED45000 - 00000000FED8FFFF] Motherboard resources
	[00000000FED90000 - 00000000FED93FFF] Motherboard resources
	[00000000FEE00000 - 00000000FEEFFFFFFF] Motherboard resources
	[00000000FF000000 - 00000000FFFFFFFF] Legacy device
	[00000000FF000000 - 00000000FFFFFFFF] Motherboard resources

## B.3 IRQ Mapping Chart

▼		<b>Interrupt request (IRQ)</b>	
		(ISA) 0x00000000 (00)	System timer
		(ISA) 0x00000008 (08)	System CMOS/real time clock
		(ISA) 0x0000000B (11)	Communications Port (COM9)
		(ISA) 0x0000000E (14)	Motherboard resources
		(ISA) 0x00000036 (54)	Microsoft ACPI-Compliant System
		(ISA) 0x00000037 (55)	Microsoft ACPI-Compliant System
		(ISA) 0x00000038 (56)	Microsoft ACPI-Compliant System
		(ISA) 0x00000039 (57)	Microsoft ACPI-Compliant System
		(ISA) 0x0000003A (58)	Microsoft ACPI-Compliant System
		(ISA) 0x000001FB (507)	Microsoft ACPI-Compliant System
		(ISA) 0x000001FC (508)	Microsoft ACPI-Compliant System
		(ISA) 0x000001FD (509)	Microsoft ACPI-Compliant System
		(ISA) 0x000001FE (510)	Microsoft ACPI-Compliant System
		(ISA) 0x000001FF (511)	Microsoft ACPI-Compliant System
		(PCI) 0x0000000B (11)	Mobile 6th/7th Generation Intel(R) Processor Family I/O Thermal subsystem - 9D31
		(PCI) 0x00000008 (11)	Mobile 6th/7th Generation Intel(R) Processor Family I/O SMBUS - 9D23
		(PCI) 0x00000010 (16)	High Definition Audio Controller
		(PCI) 0x00000014 (20)	Intel(R) Serial IO UART Host Controller - 9D27
		(PCI) 0x00000015 (21)	Intel SD Host Controller
		(PCI) 0xFFFFFFF6 (-10)	Intel(R) Management Engine Interface
		(PCI) 0xFFFFFFF7 (-9)	Intel(R) HD Graphics 620
		(PCI) 0xFFFFFFF8 (-8)	Intel(R) USB 3.0 eXtensible Host Controller - 1.0 (Microsoft)
		(PCI) 0xFFFFFFF9 (-7)	Intel(R) I211 Gigabit Network Connection
		(PCI) 0xFFFFFFFA (-6)	Intel(R) I211 Gigabit Network Connection
		(PCI) 0xFFFFFFF8 (-5)	Intel(R) I211 Gigabit Network Connection
		(PCI) 0xFFFFFFF8 (-4)	Intel(R) I211 Gigabit Network Connection
		(PCI) 0xFFFFFFF8 (-3)	Standard SATA AHCI Controller
		(PCI) 0xFFFFFFF8 (-2)	Mobile 6th/7th Generation Intel(R) Processor Family I/O PCI Express Root Port #3 - 9D12

# Appendix C

---

## Mating Connectors and Cables

## C.1 List of Mating Connectors and Cables

---

The table notes mating connectors and available cables.

Connector Label	Function	Mating Connector		Available Cable	Cable P/N
		Vendor	Model No		
<b>CN29</b>	External RTC Connector	Molex	51021-0200	Battery Cable	1750113019
<b>FAN</b>	CPU Fan Connector	Molex	51021-0400	N/A	N/A