

USER'S MANUAL

AMB-513 Series

*Flat Panel Industrial
panel PCs*

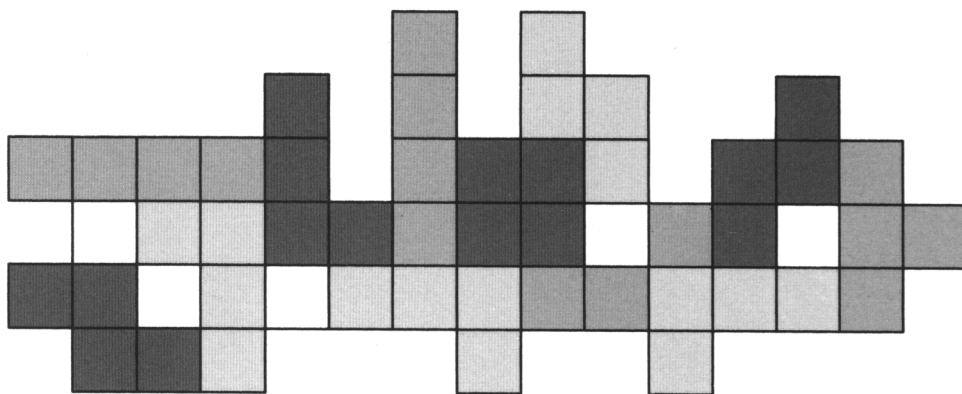

Table of Contents

About This Manual	1
Chapter 1 Overview	2
1.1 General	2
1.2 Features	3
1.3 Specification	4
1.4 Dimensions	6
Chapter 2 System Setup	7
2.1 General	7
2.2 Open The top Cover	8
2.3 Install the PC/104 LCD/CRT control module	9
2.4 Install Add-On Cards	10
2.5 Install The Disk Drives	11
2.6 The Keyboard (option)	12
2.7 Panel Mounting	13
Chapter 3 Maintenance	14
3.1 General	14
3.2 Passive Backplane	15
3.3 Power Supply	16
3.4 Cooling Fan	17
Appendix A Power Supply Specification	18
Appendix B Exploded Diagram	20

About This Manual

The manual is made to help you understand how to set up and use the AMB-513 series industrial panel PCs. It is divided into three chapters and two appendixes. Chapter one gives you an overview of the workstations. Chapter two tells you how they are basically constructed and what procedures you should take for system setup or upgrading. Chapter three tells you how to maintain them. Appendix A gives detailed specifications of power supply used in them. Appendix B gives a picture of exploded diagram on them.

But before we come to all that the first thing you should do when you receive your unit is check if it is the right version you ordered. The series has four versions respectively named as: AMB-513M, AMB-513C, AMB-513E, AMB-513T (please refer to the display selection table in section 1.3 for details). Then you should also check if the package contains the following items. You should contact your dealer immediately if any of them is missing or damaged:

- * One AMB-513 industrial panel PC with flat panel display
- * One flat panel/CRT display control piggyback module
- * One power cord
- * One accessory box
- * One user's manual

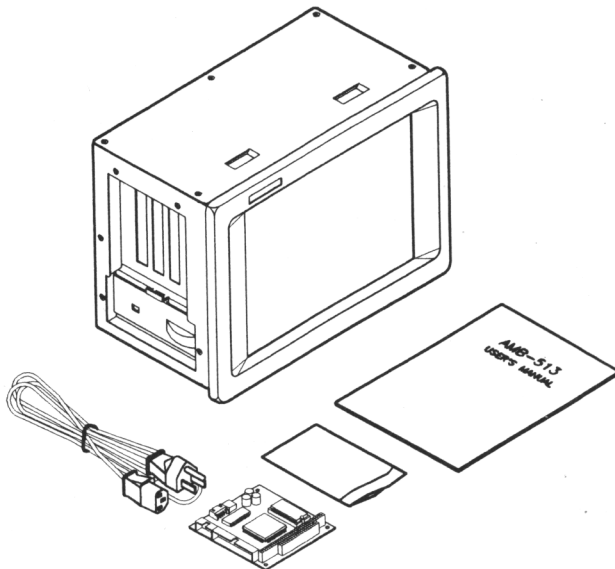

Chapter 1 Overview

1.1 General

The AMB-513 series industrial panel PCs are IBM PC/AT compatible computers specially designed to meet all the requirements for an industrial man-machine interface. They come equipped with one of the following flat panel displays: 10.4" color TFT LCD, color D_STN LCD, EL, or 9.4" B/W LCD; an ISA-bus 4-slot passive backplane; a universal 65W switching power supply (refer to the selection table for other options); a PC/104-bus flat panel/CRT display control piggyback module; one disk drive housing (for one 3.5" FDD and one 3.5" HDD). All of them are enclosed with a heavy-duty steel chassis and a plastic front panel which meet the NEMA 4/12 industrial and environmental protection standards.

You can also add a touchscreen (option) to the panel PCs. That allows you to control functions and processes simply by touching the figures shown on the screen.

A 20-function keypad (option) is also available for you to choose if you want to have a user's interface added to the panel PCs (refer to section 2.6 for details).

1.2 Features

- * Heavy-duty steel chassis, NEMA 4/12 plastic front panel
- * 10.4" color TFT LCD, color D_STN LCD, EL, or 9.4" B/W LCD
- * Analog resistive touchscreen (option)
- * ISA-bus 4-slot passive backplane
- * Universal 65W switching power supply (or other options)
- * PC/104-bus flat panel/CRT display control piggyback module
- * A 20-function keypad (option)
- * One disk drive housing: for one 3.5" FDD and one 3.5" HDD
- * One 27 CFM cooling fan
- * Hold-down clamp for keeping add-on cards from vibration
- * Panel mounting

1.3 Specification

* General

Construction: heavy-duty steel chassis, NEMA 4/12 plastic front panel

Disk Drive housing: for one 3.5" FDD and one 3.5" HDD

Cooling system: one 27 CFM fan

Dimensions: 301mm(W)x216mm(H)x151mm(D)

Weight: 6 kgs

* Display

(refer to the selection table)

* Power supply

(refer to the selection table and appendix A)

* Passive backplane

4-slot ISA-bus passive backplane:

4-layer PCB with ground/power-plane for reduction in noise and power supply impedance.

LED power indicators for +5V, -5V, +12V, -12V.

* Environmental

Operating temperature: 0°C to 45°C

Storage temperature: -20°C to 60°C

Relative humidity: 5 to 95%, non-condensing

Altitude: 10,000 ft (3000 meters)

Vibration: 5 to 17 Hz, 0.1" double-amplitude displacement

17 to 500 Hz, 1.5 G peak to peak

Shock: 10 G peak acceleration (11 msec. duration)

Safety: meets UL/CSA/TUV

EMI: meets FCC/VDE Class A

*** Display Selection Table**

Item	Mono_DD	Color D_STN	Color TFT	EL VGA
Diagonal	9.4"	10.4"	10.4"	10.4"
Display area	196(H) x147.6(V)	214.2(H) x164.4(V)	211.2(H) x158.4(V)	211.1(H) x158.3(V)
Resolution	640 x 480	640 x 480	640 x 480	640 x 480
Color or Gray scale	16 gray scales	16 colors	256 colors	4 gray scales

** AMB-513M: with Mono_DD

AMB-513C: with Color D_STN

AMB-513T: with Color TFT

AMB-513E: with EL

(When you opt for a touchscreen, the above version names will be attached with a T, AMB-513TT as an example)

*** Touchscreen (option)**

(refer to the touchscreen user's guide which will be included in the package if you opt for a touchscreen)

*** Power Supply Selection Table**

Model	Input voltage	Max. Output Current			
		+5V	+12V	-5V	-12V
Universal/65W	90-260VAC	4A	3A	0.3A	0.3A
24VDC/65W	19V-30VDC	6A	2A	0.3A	0.5A
12VDC/65W	8.5V-16VDC	6A	2A	0.3A	0.5A

1.4 Dimensions

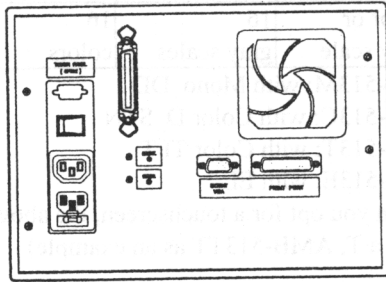
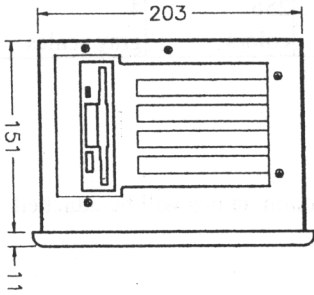

REAR VIEW

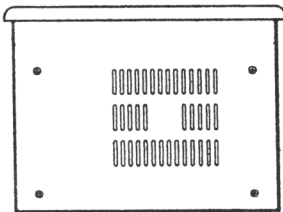
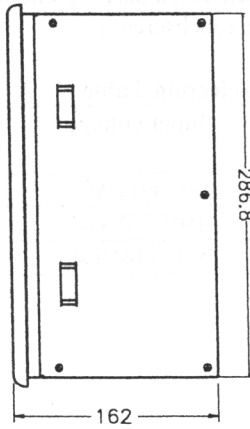
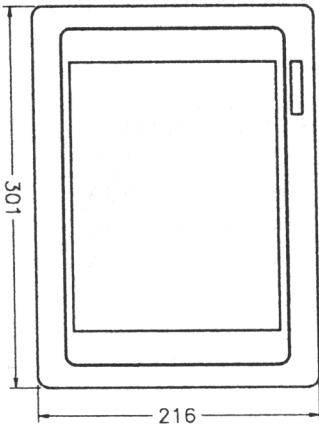

Chapter 2 System Setup

2.1 General

The AMB-513 panel PCs are very easy to set up for operation, all you have to do is open their top and bottom covers to install your CPU card, display control module, hard disk drive and other I/O cards required by your application, and you are ready to mount them onto a panel control and start operating. You can be assured of that because we have set them up and tested them at our factory before they were shipped.

But before you come to that you should first make sure that: ***you haven't plugged in any power and if you have you should now switch them off and unplug them. Also remember that each time you want to open the panel PCs again for either upgrading or maintenance you have to switch all the power off and unplug them.***

2.2 Open the top cover

The top cover is fastened to the chassis with six screws, you need only to unfasten them to open the cover.

Once opened you will see a rubber band fixed on the inner side of the cover, which is to hold down all the add-on cards you may install inside.

2.3 Install the PC/104 LCD/CRT control module

The panel PCs come with a PC/104 LCD/CRT display control module, which should be piggybacked onto your CPU card first before the latter is installed. Do remember to add the two screws (which always come when you purchase a CPU card) in a way as shown on the figure below to secure the module to the CPU card.

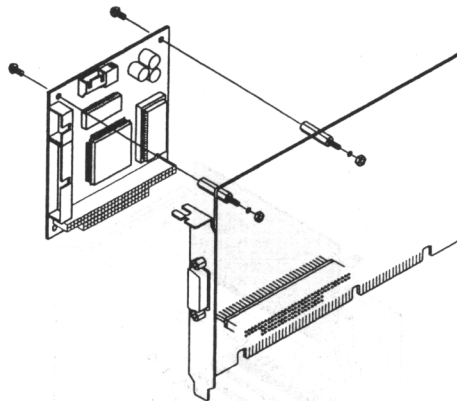

2.4 Install add-on cards

There are 4 slots on the passive backplane, but for the sake of saving them you should basically install an all-in-one SBC and the flat-panel/CRT display control module which comes with the panel PCs before taking up any of other I/O cards.

Steps for installing are:

1. Take up a card and slide it slowly into a slot until its bracket goes well down a groove on the securing panel.
2. Match the screw hole on the bracket with the one on the groove and drive a screw tight through.

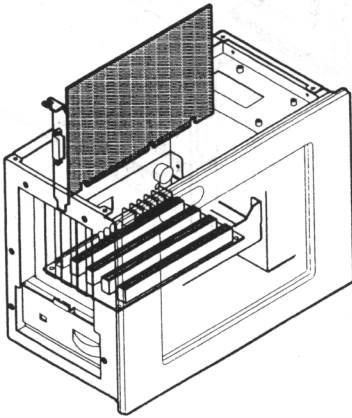

2.5 Install the disk drives

There are one disk drive housing equipped in the panel PCs. It is for you to install one 3.5" FDD and one HDD. You need to take it out to install. To do that you need to put the panel PCs upside down, open the bottom cover by unfastening the five screws on it. Then unfasten the two screws which secure the housing to the chassis and it can be taken out.

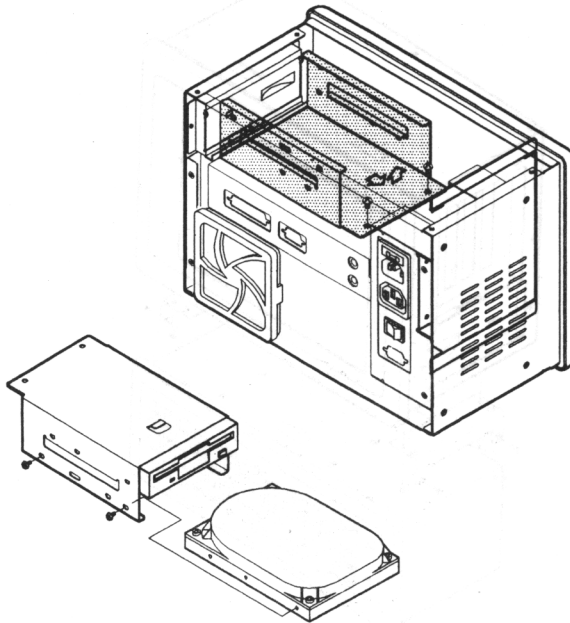

2.6 The keypad (option)

2.2 Install the disk drive

In section 1.1 we said you can add a user's interface to the panel PCs, and there is one we have developed for your option. Hereof we tell you how to set it up. The keypad comes with two brackets, on which you can see two pairs of screws each with different heads, round and countersunk. Drive first the round-headed pair into the two holes you can see on the bottom of the chassis, then set the chassis with the secured bracket on the keypad, and drive the other pair of screws into the two holes you can see on its both sides.

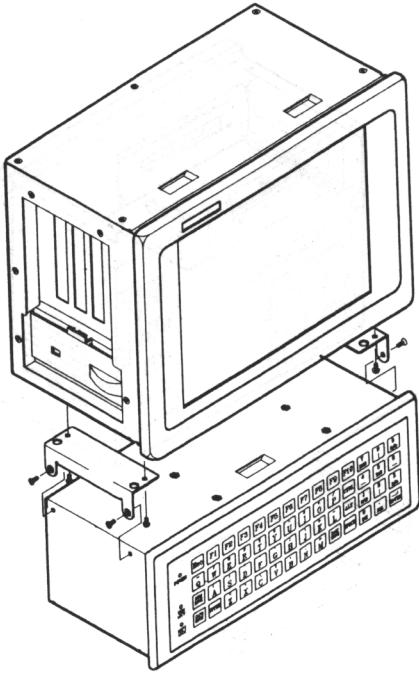

2.7 Panel mounting

Now you have set up the panel PCs and you are ready to mount it onto a panel control. Hereof we give you the dimensions of the aperture you should make on the panel control. To mount them in the aperture first, then put the four securing kits you can find in the accessory box into the four slots on the chassis. Then drive the four screws on the kits tight through against the panel control.

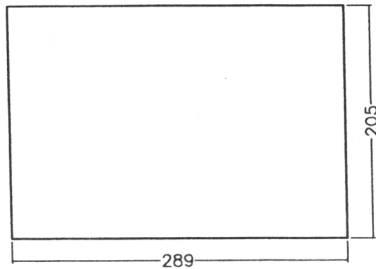
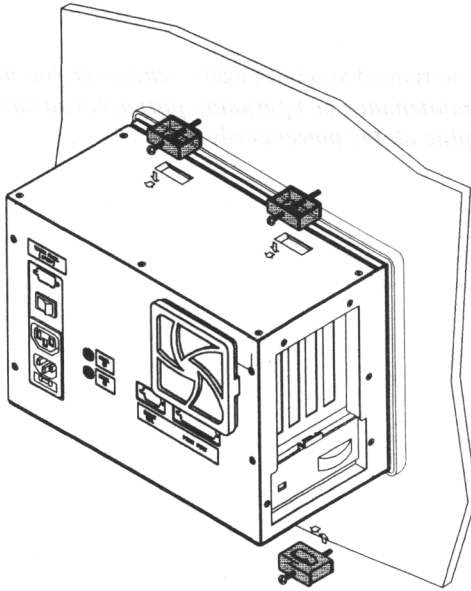

Chapter 3 Maintenance

3.1 General

Now you have known how to set up the panel PCs for operation, hereafter we shall tell you how to maintain them during the operation. There are other essential parts which we haven't mentioned of so far but you will need to know them sooner or later during the operation for the purpose of either maintenance or upgrading. In the following sections they will be introduced to you one by one, and after you have gone through all them you will know almost all the essential parts in the panel PCs, as well as how to take each of them down and put back.

But hereof we would like to remind you once again: ***whenever you need to take down a part for either maintenance or upgrading purpose, you should switch off all the power and unplug all the power cords first.***

3.2 Passive backplane

As we said in section 1.1 the panel PCs come with an ISA-bus 4-slot passive backplane. In case that you need to take it down for the purpose of either maintenance or upgrading, here are the steps you should follow:

1. Remove all the add-on cards and connecting cords on it
2. Unfasten the 4 screws which fasten it to the bracket below.



3.3 Power supply

A universal 65W switching power supply is provided in the panel PCs (for other options please refer to appendix A). It is placed in the lower right corner of the chassis, fastened with two screws from outside. So you need only to unfasten the two screws to take it out for the purpose of either maintenance or upgrading.

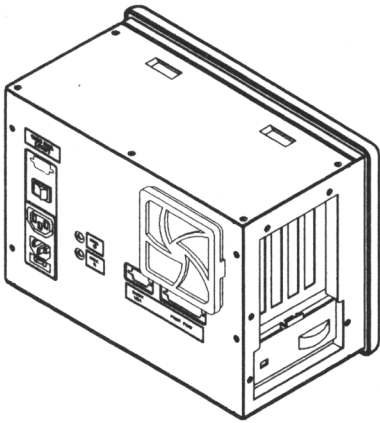

FOR INPUT AC POWER

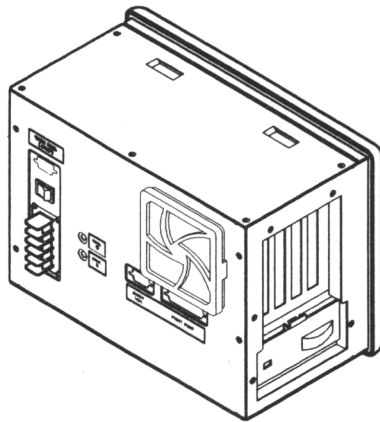

FOR INPUT DC POWER

3.4 Cooling fan

To keep the inside of the chassis cool, a 27 CFM fan is installed on the right side of the chassis in a niche, with four screws fastening it from outside. To take it out you need only to unfasten the four screws. The filter is placed separately on the lower left corner on the chassis' back, behind a plastic cover. So you need only to take off the cover to reach the filter. You are advised to clean and replace the filter from time to time, and the frequency will depend on how susceptibility to pollution you will expose the panel PCs to.

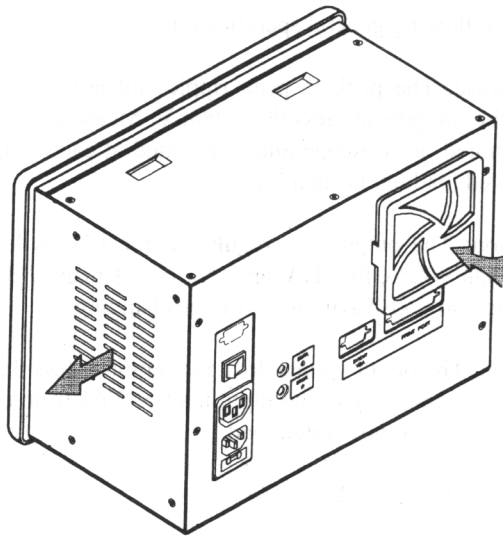

Appendix A

Power supply specification

Power supply constitutes an essential part of the panel PCs, so we make this section to let you know more about the power supply used in them. It is a universal 65W AC switching power supply (default), and it has the following industrial features:

- * 85-265 VAC input
- * 47-63Hz and 440Hz input frequency
- * 100% equipped "NIPPON CHEMI-CON" super high reliability aluminum electrolytic capacitors
- * 60KHz switching frequency control IC inside
- * 0-60C operation temperature
- * High reliability "ball bearing" cooling fan
- * High precision and stable DC outputs for long term operation

It also has the following general specifications:

Ripple and Noise: The peak to peak ripple and noise for +12V is less than 50mV. The other outputs are less than 100mV. Measurement is done by 15Mhz band width limited oscilloscope and terminated at each output with a 0.47 uF capacitor at rated loading, normal line.

Line Regulation: The output line regulation for +5V is less than +/-1%, for +12V is less than +/-2%, for -12V and -5V is less than +/-3% while measuring at rated loading and +/-10% of input voltage changing.

Load regulation: The output voltage load regulation is less than the values in the following table by changing each output load +/-40% from 60% rated load, and keep all other outputs at 60% rated load.

Output # +5V: +/-3%	+12V: +/-3%
-5V: +/-5%	-12V: +/-5%

Hold-up Time: Hold-up time is 16ms typical by measuring from the last AC line changing pulse to the point that +5V drop down to +4.75V

Power Good Signal: When power is turned on, the power-good signal will go high for 100ms to 500ms after all output DC voltages are within regulation limits.

Output Protection: The built-in over voltage protection circuit will shut down the outputs to prevent damaging external circuits. The trip point of crowbar circuit is around 5.9V to 7.0V. The power supply will go into hiccup mode against short circuit or over load conditions, and will auto-recover while faulty conditions are removed.

Efficiency: The efficiency is higher than 73% by measuring at nominal line and rated load.

Safety: Designed to meet the following standards

UL 1950 D3

TUV EN60 950

CSA 22.2 No. 234

EMI: Designed to meet the FCC docket 20780 curve "B"

AC Connectors:

AC Inlet: Molex 5277-02A or equivalent

DC Connectors: Molex 5273-07 A or equivalent

Operating Temperature: 0 to 55C

Storage Temperature: -20C to 85C

Appendix B Exploded diagram

