

AMB-2427/2457/

2450 Series

12.1/15" TFT Flat-panel

Industrial Workstation

Packing List

Before you set up the AMB-24xx Serial workstation, make sure that the following items have been included in your package, and that this manual is in good condition. If anything is missing or damaged, contact your dealer immediately.

- An AMB-2427/2457/2450 Industrial workstation
- An AMB-2427/2457/2450 User's manual Disk
- A MBC-6210 CPU card
- A MBC- 6210 User's manual
- Four MBC-6210 driver disks
- Accessory bag
- A power cord
- Screw bag with screws
- With Touch Screen Option
 - Penmount User's manual
 - Four Penmount Driver disks

Safety & Warranty

1. Read these safety instructions carefully.
2. Keep this user's manual for later reference.
3. Disconnect this equipment from any AC outlet before cleaning. Do not use liquid or spray detergents for cleaning. Use a damp cloth.
4. For pluggable equipment, the power outlet must be installed near the equipment and must be easily accessible.
5. Keep this equipment away from humidity.
6. Put this equipment on a reliable surface during installation. Dropping it or letting it fall could cause damage.
7. The openings on the enclosure are for air convection. Protect the equipment from overheating. **DO NOT COVER THE OPENINGS.**
8. Make sure the voltage of the power source is correct before connecting the equipment to the power outlet.
9. Position the power cord so that people cannot step on it. Do not place anything over the power cord.
10. All cautions and warnings on the equipment should be noted.
11. If the equipment is not used for a long time, disconnect it from the power source to avoid damage by transient over-voltage.
12. Never pour any liquid into an opening. This could cause fire or electrical shock.
13. Never open the equipment. For safety reasons, only qualified service personnel should open the equipment.
14. If any of the following situations arises, get the equipment checked by service personnel:
 - a. The power cord or plug is damaged.
 - b. Liquid has penetrated into the equipment.
 - c. The equipment has been exposed to moisture.
 - d. The equipment does not work well, or you cannot get it to work according to the user's manual.
 - e. The equipment has been dropped and damaged.
 - f. The equipment has obvious signs of breakage.
15. **DO NOT LEAVE THIS EQUIPMENT IN AN UNCONTROLLED ENVIRONMENT WHERE THE STORAGE TEMPERATURE IS**

BELOW -20° C (-4° F) OR ABOVE 60° C (140° F). IT MAY DAMAGE THE EQUIPMENT.

FCC Safety

This device complies with Part 15 FCC Rules. Operation is subject to the following two conditions: (1) this device may not cause harmful interference, and (2) this device must accept any interference received including interference that may cause undesired operation.

Warning!



Contents

Packing List	2
Safety & Warranty.....	3
FCC Safety.....	4
General Information	6
Introduction.....	7
Specifications	10
Basic Operations	14
Dimension.....	16
Rack Mounting.....	18
Hardware Installation.....	19
Exploded Diagram	20
Passive Back plane.....	22
Install CD-ROM , Hard Disk Drives and Floppy Disk Drive	24
Power Supply Replacement	28
Cooling Fan replacement	29
CPU Card Installation.....	31
VGA Jumper setting.....	34
Power Supply Specification	35
Power Supply Specification	36

Chapter

1

**General
Information**

Introduction

Astech designed the AMB-2427/2457/2450 specifically for the factory floor and other harsh industrial environments. This 19" rack/panel-mount workstation offers full state-of-the-art industrial computing technology packaged within one compact unit. It includes a 12.1" SVGA/15" XGA color TFT LCD monitor, 7/10-slot passive backplane, 250-watt power supply, 3½" floppy disk drive, slim CD-ROM and 3½" HDD, front PS/2 keyboard connectors and a sealed front panel that conforms to NEMA 4 and IP56 specifications. All of these features are housed in a rugged workstation chassis, which provides protection from dust, vibration and moisture.

The Modular System Design makes AMB-24xx series could open front with a key lock, CD-ROM & FDD is secure in it. Front panel is removable when install. This makes LCD and control box as two system increasing the reliability

12.1" SVGA color TFT LCD

- Luminance High brightness 250cd/m²
- High-resolution display 800 x 600
- Long Backlight Life time 25,000 Hrs

15" XGA color TFT LCD

- Luminance High brightness 250cd/m²
- High-resolution display 1024 x 768
- Long Backlight Life time 25,000 Hrs

59-key sealed-membrane operating keypad

You can enter numerical data using the workstation's convenient 59-key sealed-membrane operating keypad. The keypad has excellent tactile response. You can also attach an external keyboard through a connector

on the front panel.

Finger Mouse

Finger mouse is a standard function at AMB-24xx series. It's a standard PC compatible mouse and make this workstation have full function assist you to control everything with this workstation.

Front-accessible control panel

You can easily access the workstation's controls from the front of the unit via a sturdy protective door. Controls include switches for power. The front panel also holds a 3½" 1.44MB FDD and a CD ROM. The aluminum door protects the controls from the environment outside. The door has a waterproof foam-rubber seal and captive hand screw to hold it closed. In addition, the door offers protection against accidental operation of the unit's controls.

Key Lock

This design like a key make front panel open and closed also could secure Power switch, CD-ROM and FDD. It also could lock it with a key

Brightness Control and LCD on/off switch

This function could control the LCD brightness and could turn off the LCD backlight to save the life time. The brightness control to increasing or decreasing the LCD brighten.

Passive backplane

The AMB-24xx series offers two types of passive backplane, the 3PCI, 1 ISA/PCI, 3 ISA. They allow you to run your industrial applications from a variety of full-featured CPU cards.

The back planes are formed from four-layer PCBs with ground and power planes to reduce noise and power-supply impedance. They have LED

power indicators for +5 V, +12 V, -5 V and -12 V.

Specifications

General

- **Construction:** Painted metal steel chassis & aluminum alloy
- **Disk drive housing:** One 3½ " FDD, one slim CD-ROM
& one 3½ " HDD
- **Cooling system:** One 64 CFM fan
- **Dimensions:**
 - (W x H x D) 483 x 355 x 225mm (AMB-2450)
 - (W x H x D) 483 x 355 x 236mm (AMB-2457)
 - (W x H x D) 483 x 310 x 236mm (AMB-2427)
- **Gross Weight:** 18Kg (AMB-2427/2457)
20.5Kg (AMB-2450)

LCD display

Model	AMB-2457/2450	AMB-2427
Display type	TFT color LCD	TFT color LCD
Size (diagonal)	15"	12.1"
Number of Pixels	1024(W) x 768(H)	800(W) x 600(H)
Dot size (mm x mm)	0.313(W) x 0.329(H)	0.3075(W) x 0.3075
Contrast ratio	300	250
View angle (Horizontal)	160°	120°
View angle (Vertical)	160°	100°
Luminance (cd/m²)	250	250
Operating Temperature	0 ~ 50 °C	0 ~ 50 °C
Backlight Life-time (Hrs)	25,000	25,000

Front panel

- **Keypads:** One with 59 operating keys, one with 24 function keys
- **Keyboard connector:** PS/2 connector with dust-protection cover on front panel

If you would like to connect external keyboard or mouse, please notice:

The PS/2 connector on front panel of AMB-2450 series support external keyboard only

The PS/2 connector at CPU card's bracket support PS/2 mouse only, because the signals are connected to membrane keypad/PS2 ports at front panel

- **Brightness control:** LCD backlight on/off, brighten increasing/decreasing
- **Key Lock:** Lock, front door open /closed
- **Finger Mouse:** Function as mouse and have right and left bottom

Passive backplane

- **4 PCI, 2 ISA/PCI, 4 ISA slot passive backplane (AMB-2427/2457)**
- **3PCI, 1 ISA/PCI, 3ISA slot passive backplane (AMB-2450)**

Power supply

AC input 250 W (standard offer)

- **Input voltage:**
90 ~ 265 V AC @ 47 ~ 63 Hz, switching
- **Output voltage:**
+5 V @ 24 A; +12 V @ 12 A; -5 V @ 1 A; -12 V @ 1 A
- **MTBF** >120000Hrs per MIL – Handbook 217F
- **Safety:** UL/CUL/TUV approved

24 V DC input 250 W (optional)

- **Input voltage:** 19 ~ 32 VDC

- **Output voltage:**
+5 V @ 25 A; +12 V @ 10 A; -5 V @ 1 A; -12 V @ 1 A
- **MTBF:** >150000Hrs per MIL – Handbook 217F
- **Safety:** meet UL/CSA/TUV

Touchscreen (Optional)

- Type: Analog resistive
- Resolution 1024 x 1024
- RS-232 Interface
- Support 8 wire touchscreen
- Visible Light Transmission: > 68% @ 550nm
Reflection: > 25% @ 550nm
- Provide DOS, Windows 95/98 & Windows NT/2000 Driver.

Environmental specifications

- **Operating temperature:** 0 ~ 50 ° C (32 ~ 122 ° F)
- **storage temperature:** -20 ° to 60 ° C
- **Relative humidity:** 5 ~ 95% @40 ° C, non-condensing
- **Vibration:**
5 ~ 17 Hz, 0.1" double-amplitude displacement
17 ~ 500 Hz, 1.5 G peak to peak

Basic Operations

All the operations of your works can be down from panel. You can enter any kind of data by using the two sealed membrane keypads: one with 59 data keys and the other with 24 function keys or connect external keyboard for fast data key in. Finger mouse could support the quick mouse course moving. Make the control of workstation much easy. Furthermore, opening the front door you can use 3.5" FDD & CD-ROM to read/write data and secure the data and information with the lock.

1. Front Panel Function

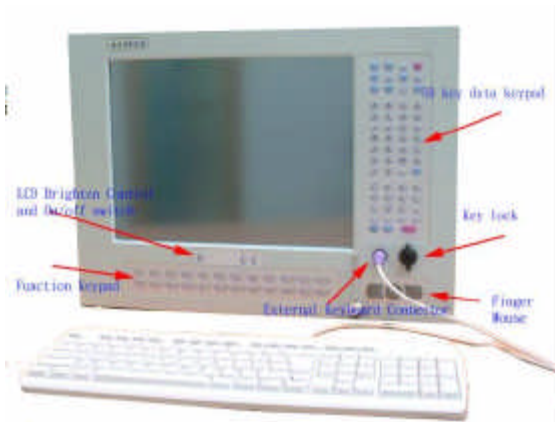

2. Open front Panel function



3. Front Panel real side



Dimension

AMB-2427series

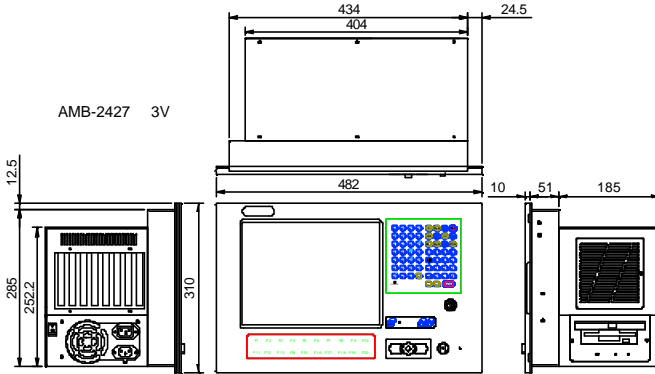

AMB-2457series

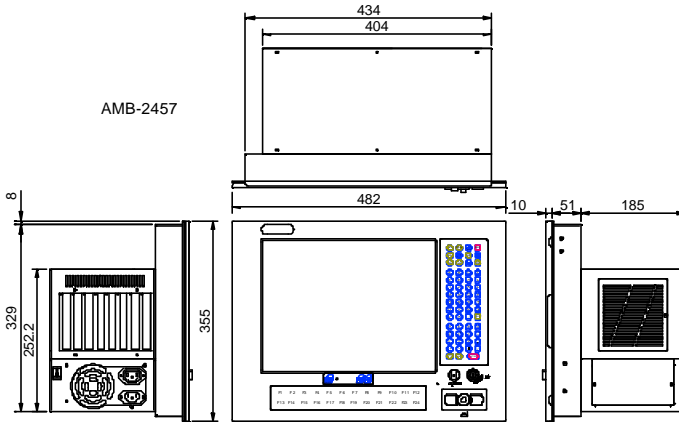

AMB-2450series

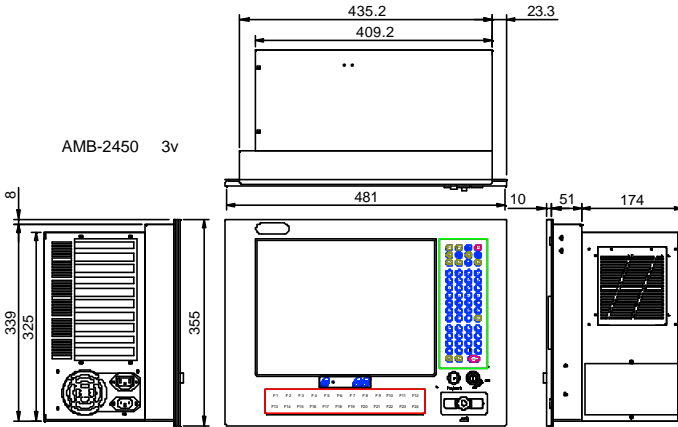

Rack Mounting

The AMB-24xx series can be mounted in a 19" rack. Ensure that all additional equipment has been installed correctly and that the cabling has been reattached. (See Fig.)

1. Turn on the front panel
2. Take off the transfer cable
3. Move up the front panel
4. Separate the front panel with control box
5. Remove the screw covers on the front panel. Attach the case to the rack using screws on both sides.

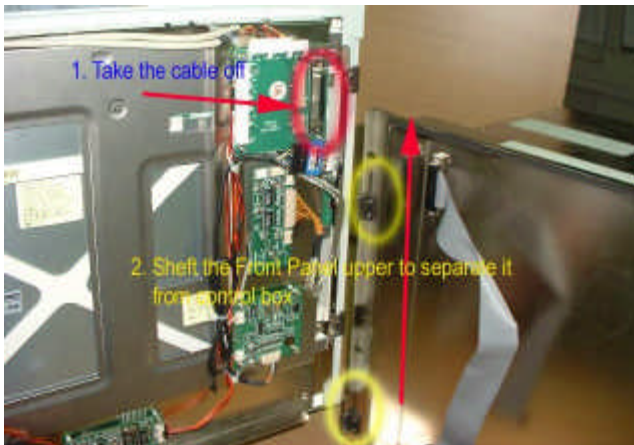

Chapter

2

**Hardware
Installation**

AMB-2457series

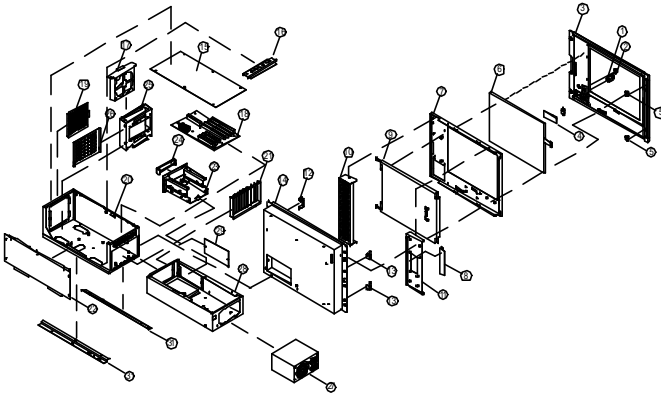

AMB-2450series

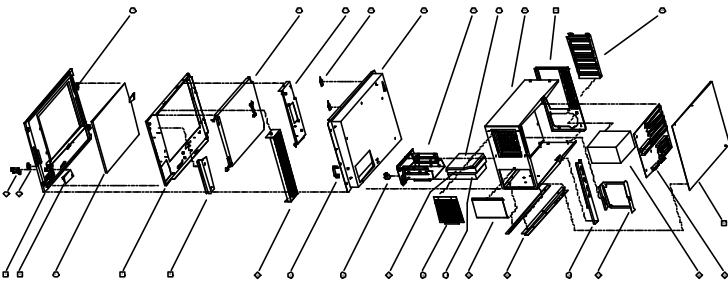

Passive Back plane

As we said in section 1.2 the workstation each come with an ISA/PCI bus 7 and 10 slots passive backplane. For the purpose of either maintenance or upgrading please follow the steps to take the backplane off.

1. Remove all the add-on cards and connecting cords on it.
2. Unfasten the screws, which was fastened behind the bracket.

7 slots passive back plane

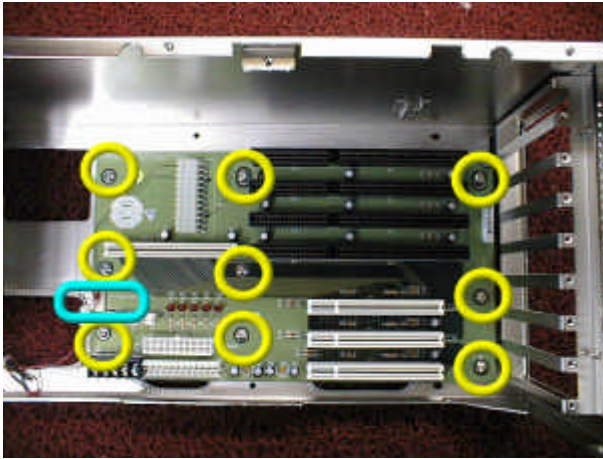

10 slots passive back plane

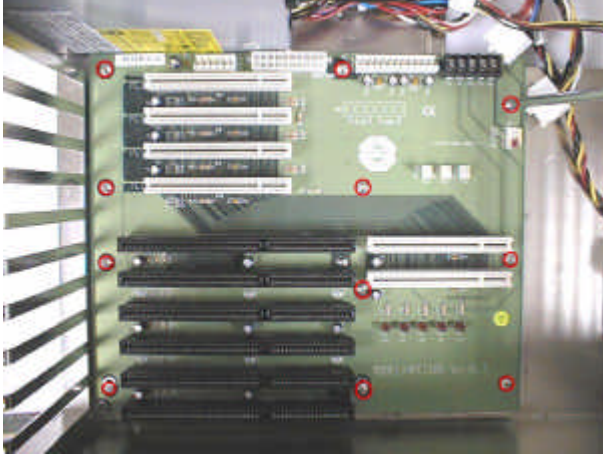

Install CD-ROM , Hard Disk Drives and Floppy Disk Drive

Every disk drive bay has a disk driver holder, which fastened to its bay with screw on the both sides. From the rear view there are three bays for installing disk drive, on the bottom is for a 3.5" HDD then middle for a 3.5" FDD, top of the disk driver holder is for a slim CD-ROM. To install disk drives, you should follow the steps:

1. Install HDD, FDD & CD-ROM in each bay

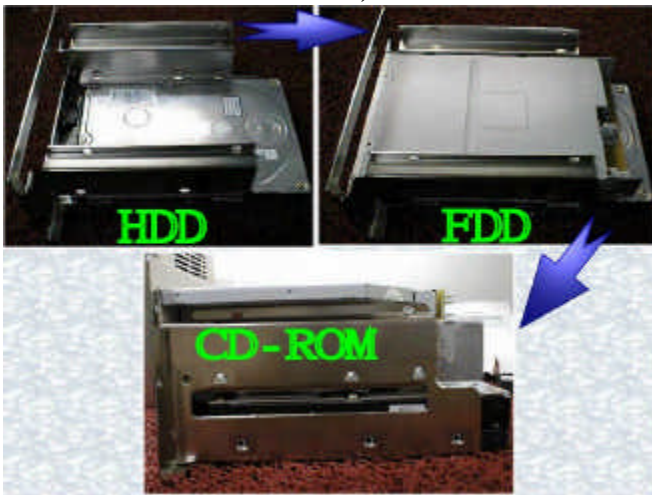

2. fastened to its bay with screw on the both sides



3. Install HDD Cable



4. Install FDD Cable



5. Install CD-ROM Cable



6. Install in Chassis



7. Fasten in chassis with two screws



Power Supply Replacement

A universal 250W switching power supply is provided in the Workstation (for other options please refer to Appendix B). Ten screws shown in the following figure fix it. Unfasten the six screws and pull it out and then you can start either maintenance or upgrading work.



Cooling Fan replacement

A 64 CFM fan is installed with in a housing to keep the working temperature inside of the chassis. You are expected to clean and replace the filter in it form time to time and for that you don't need to strip the housing and take the whole unit off. There is a small handle standing out from the housing, unfasten the single screw and pull it out by hand. The filter is coming out.

1. Two screws to fasten/loose fan

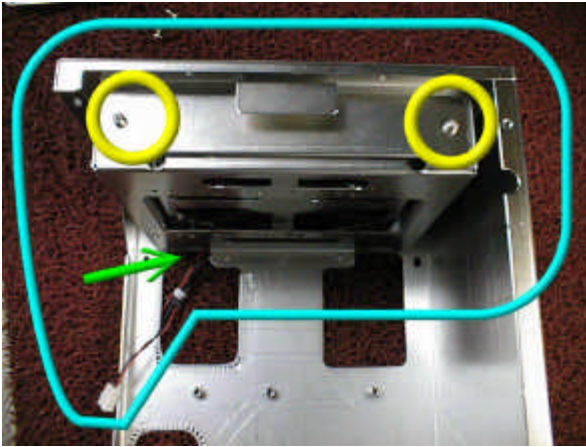

2. One screw to fasten / loose fan cover



3. Install / replace fan filter

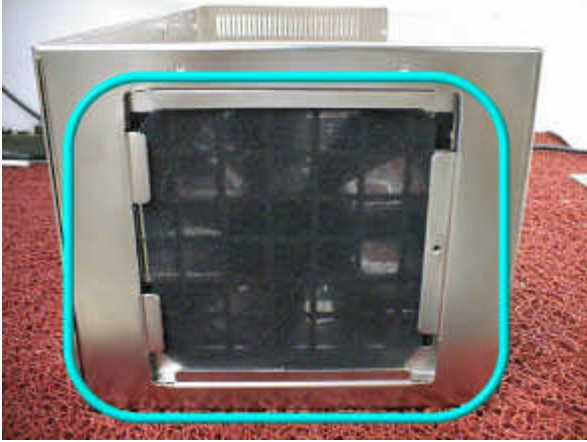

CPU Card Installation

Signal transfer between CPU card and front panel via a transfer board. The signal include Keyboard, mouse, VGA and touchscreen. It will show how to connect them in the below photo.

TB-908D Transfer Board install (1)

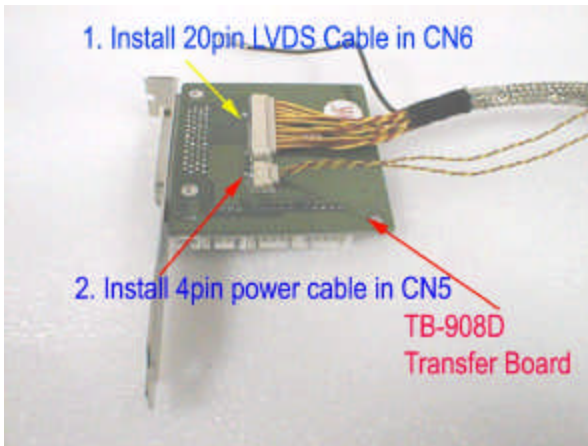

TB-908D Transfer Board install (2)

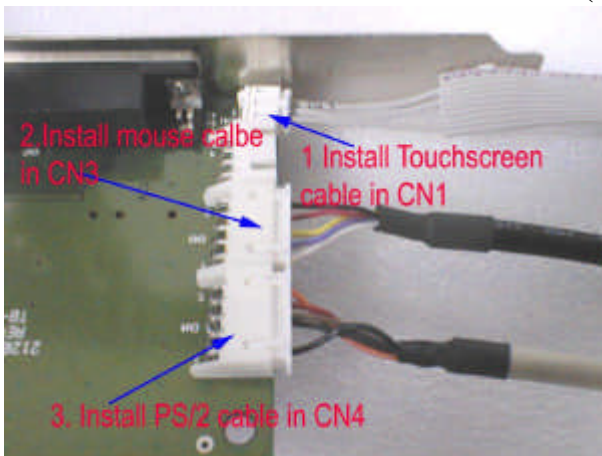

From TB-908D to CPU card (1)

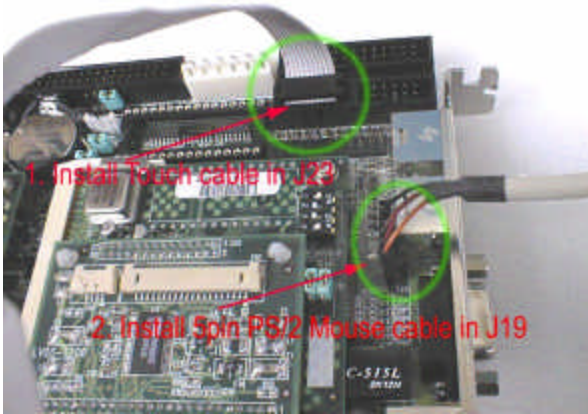

From TB-908D to CPU card (2)



From TB-908D to CPU card (3)



VGA Jumper setting

15" LCD Panel Jumper setting on DV69K

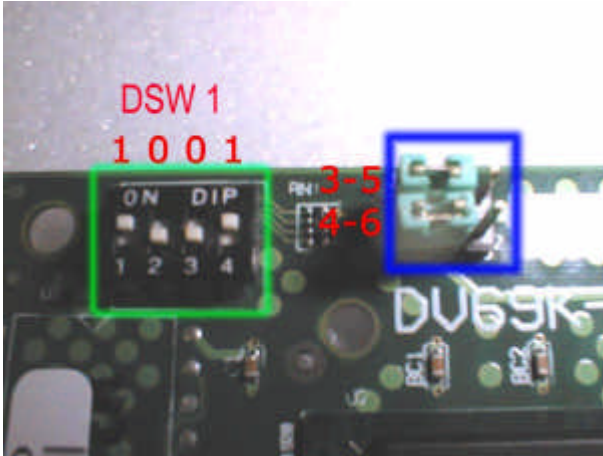

12.1" LCD Panel Jumper setting on DV69K

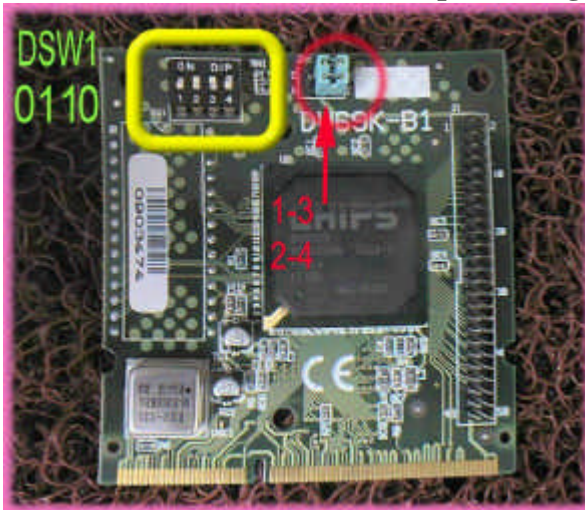

Appendix

A

Power Supply Specification

Power Supply Specification

Power supply constitutes an essential part of the panel PCs, so we make this section to let you know more about the power supply used in them. It is a universal 250W AC switching power supply (default).

Industrial Features:

- 85-265VAC input voltage
- 47-63Hz and 440Hz input frequency
- Equipped “NIPPON CHEMI-CON” super high reliability aluminum electrolytic capacitors
- 60KHz switching frequency control IC inside 55 °C operating temperature
- High reliability “Ball Bearing” cooling fan
- High precision and stable DC outputs for long term operation

General Specifications:

Ripple and Noise: The peak-to-peak ripple and noise for +12V is less than 140mV. The other outputs are less than 1% of each output voltage at rated load. Measurement is done by 15MHz-band width limited oscilloscope and terminated at each output with a 47 uF capacitor.

Line Regulation: The output line regulation for +12V is less than +/-2%, for other outputs are less than +/-1% while measuring at rated load and +/-10% of input voltage changing.

Load regulation: The output voltage load regulation is less than the values in the following table by changing each output load +/-40% from 60% rated load, and keep all other outputs at 60% rated load.

Output # +5V: +/-3% +12V: +/-5%

-5V: +/-1% -12V: +/-1%

Hold-up Time: Hold-up Time is 16ms typical by measuring from the last AC line changing pulse to the point that +5V drop down to +4.75V

Output Protection: The built-in over voltage protection circuit will shut down the outputs to prevent damaging external circuits. The trip point of crowbar circuit is around 5.9V to 7.0V. The power supply will go into hiccup mode against short circuit or over load conditions, and will auto-recovery while faulty conditions are removed.

Efficiency: The efficiency is higher than 73% by measuring at normal line and rated load.

Safety: Designed to meet the following standards

UL 478, 1012, 1950 D3

TUV EN60 950

CSA 22.2 No. 234

EMI: Designed to meet the following standards

UL 1950 D3

TUV EN60 950

CSA 22.2 No.234

Operating Temperature: 0 to 55

Storage Temperature: -40 to 75

Selection Table

Input/Output spec. at 40

Model	Input voltage	Max. Output Current			
		+5V	+12V	-5V	-12V
Universal 250W	85-265VAC	24A	10A	0.5A	0.7A
-48VDC 250W	-40 to -65VDC	25A	8A	1A	2A
24VDC 250W	18 – 30VDC	25A	6A	1A	2A
12VDC 160W	8.5 – 16VDC	20A	4A	0.5A	0.5A