

**AMB-2021-E / 2051-E**

Modular System Industrial  
Panel PC

## Copyright Notice

---

This document is copyrighted, 2003. All rights are reserved. The original manufacturer reserves the right to make improvements to the products described in this manual at any time without notice.

No part of this manual may be reproduced, copied, translated, or transmitted in any form or by any means without the prior written permission of the original manufacturer. Information provided in this manual is intended to be accurate and reliable. However, the original manufacturer assumes no responsibility for its use, nor for any infringements upon the rights of third parties, which may result from its use.

The material in this document is for product information only and is subject to change without notice. While reasonable efforts have been made in the preparation of this document to assure its accuracy, AAEON, assumes no liabilities resulting from errors or omissions in this document, or from the use of the information contained herein.

AAEON reserves the right to make changes in the product design without notice to its users.

## Acknowledgments

---

Award is a registered trademark of Award Software International, Inc.

C&T is a trademark of Chips and Technologies, Inc.

IBM, PC/AT, PS/2 are trademarks of International Business Machines Corporation.

Intel® and Pentium® are registered trademarks of Intel® Corporation.

Microsoft Windows is a registered trademark of Microsoft Corporation.

Winbond is a registered trademark of Winbond Electronics Corporation.

All other product names or trademarks are properties of their respective owners.

## Packing List

---

Before installing your Panel PC, please check if the package contains the following items.

AMB-2021HT(T)-E/ AMB-2051HT(T)-E series Panel PC  
CD-ROM

For User's Manual, Drivers and Utilities

Accessory:

- Metal cover for LCD connector
- CD-ROM and Floppy drive's cover
- Power cable for HDD & FDD
- Power connector 2P 5mm (power connector)
- 50-pin Cable (1M) (option)
- Power cord (1.8 M)
- Wire cable for external power
- Mounting kits and screw bag
- Waterproof sponge (option)
- Adjustment panel extended line (option)

If any of these items are missing or damaged, you should contact your distributor or sales representative immediately.

## Safety & Warranty

---

1. Read these safety instructions carefully.
2. Keep this user's manual for later reference.
3. Disconnect this equipment from any AC outlet before cleaning. Do not use liquid or spray detergents for cleaning. Use a damp cloth.
4. For pluggable equipment, the power outlet must be installed near the equipment and must be easily accessible.
5. Keep this equipment away from humidity.
6. Put this equipment on a reliable surface during installation. Dropping it or letting it fall could cause damage.
7. The openings on the enclosure are for air convection. Protect the equipment from overheating. **DO NOT COVER THE OPENINGS.**
8. Make sure the voltage of the power source is correct before connecting the equipment to the power outlet.
9. Position the power cord so that people cannot step on it. Do not place anything over the power cord.
10. All cautions and warnings on the equipment should be noted.
11. If the equipment is not used for a long time, disconnect it from the power source to avoid damage by transient over-voltage.
12. Never pour any liquid into an opening. This could cause fire or electrical shock.
13. Never open the equipment. For safety reasons, only qualified service personnel should open the equipment.
14. If any of the following situations arises, get the equipment checked by service personnel:
  - a. The power cord or plug is damaged.
  - b. Liquid has penetrated into the equipment.
  - c. The equipment has been exposed to moisture.
  - d. The equipment does not work well, or you cannot get it to work according to the users manual.
  - e. The equipment has been dropped and damaged.
  - f. The equipment has obvious signs of breakage.

15. DO NOT LEAVE THIS EQUIPMENT IN AN UNCONTROLLED ENVIRONMENT WHERE THE STORAGE TEMPERATURE IS BELOW  $-20^{\circ}\text{C}$  ( $-4^{\circ}\text{F}$ ) OR ABOVE  $60^{\circ}\text{C}$  ( $140^{\circ}\text{F}$ ). IT MAY DAMAGE THE EQUIPMENT.

These products are with CE and FCC certification.

## FCC Safety

---

*Warning!*



**This device complies with Part 15 FCC Rules. Operation is subject to the following two conditions: (1) this device may not cause harmful interference, and (2) this device must accept any interference received including interference that may cause undesired operation.**



# Contents

|                                    |           |
|------------------------------------|-----------|
| Copyright Notice .....             | 2         |
| Acknowledgments .....              | 3         |
| Packing List .....                 | 4         |
| Safety & Warranty .....            | 5         |
| <b>General Information .....</b>   | <b>9</b>  |
| Introduction.....                  | 10        |
| Specifications.....                | 11        |
| Touchscreen (Optional).....        | 14        |
| LCD Specifications.....            | 14        |
| Dimensions.....                    | 15        |
| Panel Mounting.....                | 16        |
| <b>Jumper Settings.....</b>        | <b>18</b> |
| Safety precautions.....            | 19        |
| Jumpers on the E17BM.....          | 20        |
| Jumper Locations on the E17BM..... | 21        |
| <b>BIOS Settings .....</b>         | <b>24</b> |
| Main Menu .....                    | 25        |
| Standard CMOS Setup.....           | 26        |
| BIOS Features Setup .....          | 29        |
| Chipset Features Setup.....        | 32        |
| Power Management Setup .....       | 34        |
| PNP/PCI Configuration .....        | 37        |
| Integrated Peripherals.....        | 39        |
| Supervisor / User Password .....   | 42        |
| Save & Exit Setup .....            | 44        |
| Exit Without Saving .....          | 45        |
| <b>Appendix.....</b>               | <b>46</b> |
| LCD Panel Configuration .....      | 47        |



Chapter

1

**General  
Information**

## Introduction

---

The AMB-2021HT(T)-E/AMB-2051HT(T)-E series modular system panel PCs, is the PC-base industrial computer that specially designed to keep normal operation under harsh environment, which meet the entire requirement as an industrial human machine interface (HMI).

It is a full-function PC-base system with a 12.1" SVGA (800 x 600), 15.1" XGA (1024 x 768) color TFT hi-brightness, long-life time LCD display, and compact with different control modules. The compact dimensions are ideal for automation applications when the installation space is critical.

These PCs are characterized by their space saving, there is one free slot for PCI/ ISA. AMB-2021HT(T)-E/AMB-2051HT(T)-E is heavy-duty steel chassis and optional aluminum front panel, which meets the toughest industrial and environmental standards. All the controls and connectors are placed on the rear panel; you can connect the panel PCs to other devices via them.

## Specifications

---

### General

- **Construction:** Heavy-duty steel chassis
- **Disk drive housing:**  
3.5"HDD and Slim CD-ROM  
or 2.5"HDD, Slim CD-ROM & Slim FDD
- **Dimensions (AMB-2021-E):** 350(W) x 275(H) x 128mm(D)
- **Gross Weight:** 12Kg
- **OS support (AMB-2021-E1~E6):** MS DOS, Windows 98/SE, Windows NT4.0, Windows 2000  
**(AMB-2021-E7~E13):** MS DOS, Windows 98/SE, Windows NT4.0, Windows 2000, Windows XP  
**(AMB-2051-E):** MS DOS, Windows 98/SE, Windows NT4.0, Windows 2000
- **Dimensions (AMB-2051-E):** 428(W) x 320(H) x 129mm(D)
- **Gross Weight:** 12.5Kg

### Environmental

- **Operating temperature:** 0 to 45
- **Vibration:** Random Non-operation 2G 5~500Hz
- **Shock:** 15G-peak acceleration (11-msec. duration)
- **EMC:** FCC/CE Class A

## Features

AMB-2021HT(T)-E (12.1" open frame LCD+ACS-2301 Control Box)

AMB-2051HT(T)-E (15" open frame LCD+ACS-2301 Control Box)

- 12.1"SVGA/15" XGA color TFT LCD display
- Open frame architecture with heavy-duty steel chassis
- Front panel with frame is IP65 certified
- Supports Socket 370 CPU up to Pentium III 1.0GHz
- Adjustment-panel on the rear panel
- 16-bit stereo digital audio
- Disk Drive Space for CD-ROM, FDD and HDD
- DiskOnChip Flash disk socket
- One free expansion slot for ISA or PCI
- Resistive Touch Screen (optional)
- Aluminum front bezel (optional)
- Rotatable mounting mechanism (optional)(For AMB-2021HT(T)-E only)

## Features of E17BM Single Board Computer

---

- Intel 440BX AGPset
- Intel Pentium III and Celeron CPU support, up to Pentium III 1.0 GHz (FSB 66/100HGz)
- CHIPS 69000 VGA chipset
- ESS Solo-1 (ES1938S) PCI audio chip
- Realtek RTL8139B 10/100Mbps Ethernet controller
- Four COM ports (One is reserved for touchscreen)
- Hardware monitoring, DiskOnChip support, Watchdog timer

## Specifications

- **Construction:** Heavy-duty steel chassis & open frame front panel.
- **CPU:** Supports Socket 370 based Intel® Pentium® III and Celeron® CPU; up to Pentium® III 1.0GHz (FSB 66/100MHz)
- **Memory:** Supports up to 256MB
- **Display:** 12.1" SVGA (800 x 600) / 15" XGA (1024 x 768) TFT color LCD
- **LCD/CRT controller:**  
C&T 69000 VGA controller with 2MB embedded SDRAM. CRT & LCD panel support
- **Network (LAN):**  
Realtek RTL8139B 10/100 Base-T Ethernet controller
- **I/O ports:**  
4 serial ports: 3 x RS-232, 1 x RS-232/422/485 (one is reserved for touchscreen)  
1 parallel port (supports ECP/EPP)  
1 PS/2 keyboard interface  
1 PS/2 mouse interface
- **Disk Drive Housing:**  
3.5" HDD & Slim-size CD-ROM or  
2.5" HDD, Slim-size CD-ROM and slim-size FDD  
(2 types of housing are not compatible)
- **USB connector:** Dual USB ports
- **Mounting:** Panel mount and Rear mount or Wall mount (Control Box only, optional)  
For AMB-2021 series only: Handle mount
- **Expansion slots:** 1 ISA or 1 PCI slot
- **Power supply:** Universal 70W switching power supply

## Power Supply Selection Table

| Mode                 | Input voltage |
|----------------------|---------------|
| Universal/70W        | 85-270VAC     |
| 24VDC/70W (optional) | 10-30VDC      |

## Touchscreen (Optional)

- **Type:** 8-wire, analog resistive
- **Resolution:** Continuous (1024 x 1024)
- **Light transmission:**  
>75%
- **Controller:** RS-232 interface

## LCD Specifications

| Model                               | AMB-2051HT(T)-E     | AMB-2021HT(T)-E       |
|-------------------------------------|---------------------|-----------------------|
| <b>Display type</b>                 | TFT color LCD       | TFT color LCD         |
| <b>Size (diagonal)</b>              | 15"                 | 12.1"                 |
| <b>Number of Pixels</b>             | 1024(W) x 768(H)    | 800(W) x 600(H)       |
| <b>Dot size (mm x mm)</b>           | 0.313(W) x 0.329(H) | 0.3075(W) x 0.3075(H) |
| <b>View angle (Horizontal)</b>      | 160°                | 120°                  |
| <b>View angle (Vertical)</b>        | 160°                | 90°                   |
| <b>Luminance (cd/m<sup>2</sup>)</b> | 250 (TYP)           | 250 (TYP)             |
| <b>Operating Temperature</b>        | 0 ~ 45 °C           | 0 ~ 45 °C             |
| <b>Backlight Life-time (Hrs)</b>    | 50,000              | 50,000                |

## Dimensions

### AMB-2021-E

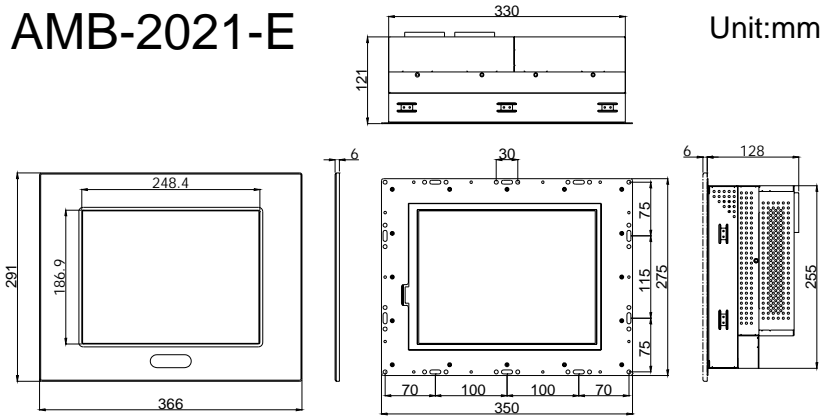

Front Bezel Size

Chassis Cutout Size:333\*258 mm  
LCD Cutout Size:248.4\*186.9 mm

### AMB-2051-E

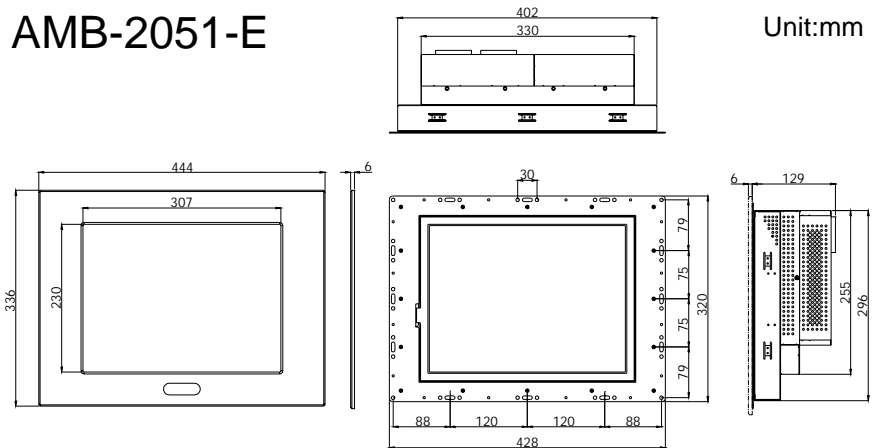

Front Bezel Size

Chassis Cutout Size:405\*299mm  
LCD Cutout Size:307\*230mm

## Panel Mounting

These display panels can be placed on a shelf or table, or mounted onto the wall. To mount them onto the wall, you need the mounting brackets, which you will find in the accessory box. Follows the steps described below:

1. Slide the display panel onto the wall.
2. Tighten the brackets until the display panel is firmly secured to the wall.

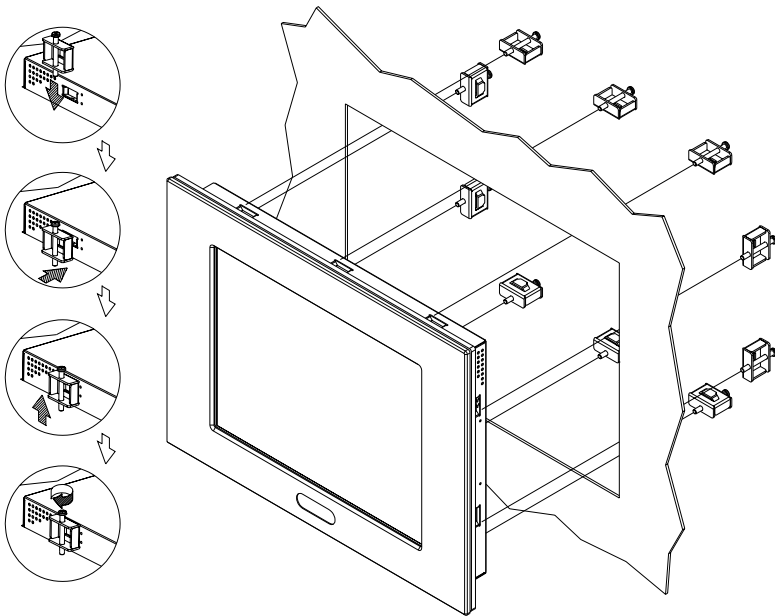



### Waterproof Sponge Position

Inside sponge:

- Tear off the protection paper on the self-adhesive side of the inside sponge.
- Stick the sponge on the recessed area of the Aluminum bezel or customer's own bezel.

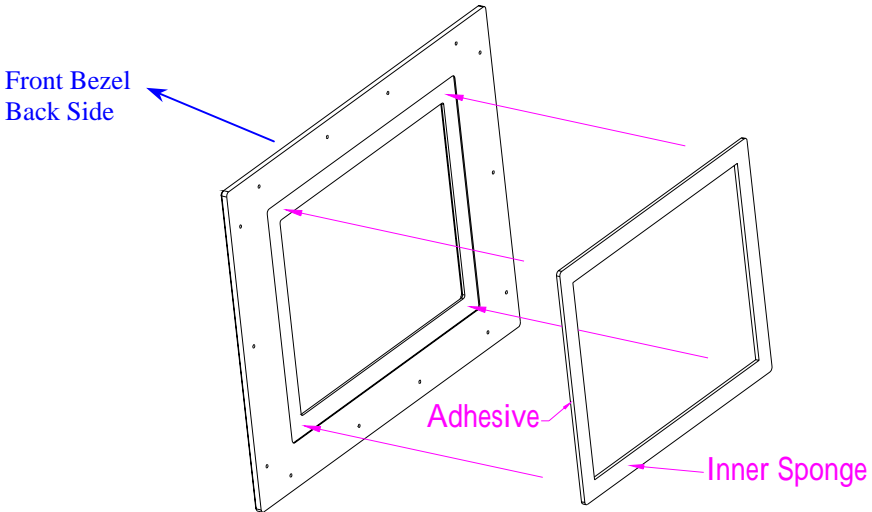

### Outer sponge :

Press to close the outer sponge to the edge of the Panel PC.

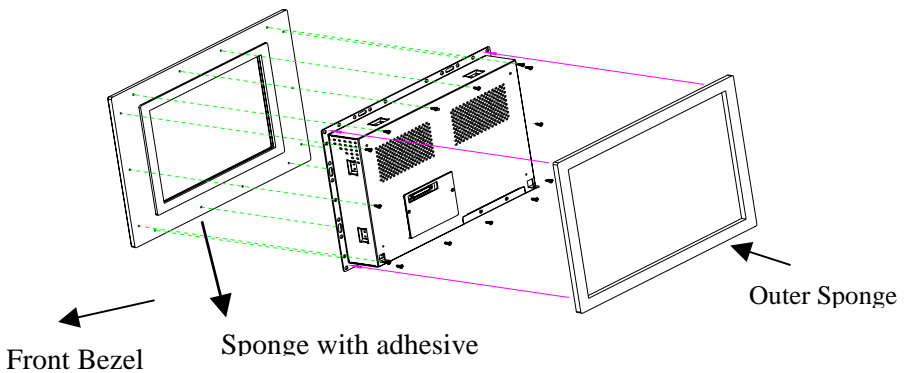

## Chapter

## 2

**Jumper  
Settings**

This chapter provides information on how to use the jumpers on the EI7BM in order to set up a workable system.

## Safety precautions

---

### **Warning!**

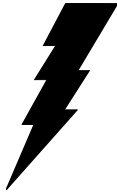

*Always completely disconnect the power cord from your chassis whenever you are working on it. Do not make connections while the power is on because sensitive electronic components can be damaged by the sudden rush of power. Only experienced electronics personnel should open the PC chassis.*

### **Caution!**



*Always ground yourself to remove any static charge before touching the CPU card. Modern electronic devices are very sensitive to static electric charges. Use a grounding wrist strap at all times. Place all electronic components on a static-dissipative surface or in a static-shielded bag when they are not in the chassis.*

## Jumpers on the E17BM

---

The jumpers on E17BM allow you to configure your system to your applications. The following table lists the jumper functions on the board.

### Jumper Locations on the E17BM

**JP5: DiskOnChip BIOS Expansion Address Select**

**JP6: Clear CMOS Content**

**JP7: External Battery Connector**

**J11: RS232/422/485 (COM2) Selection**

**Remarks:** The following conventions are used in this section:

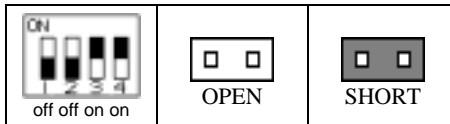

## Jumper Locations on the E17BM

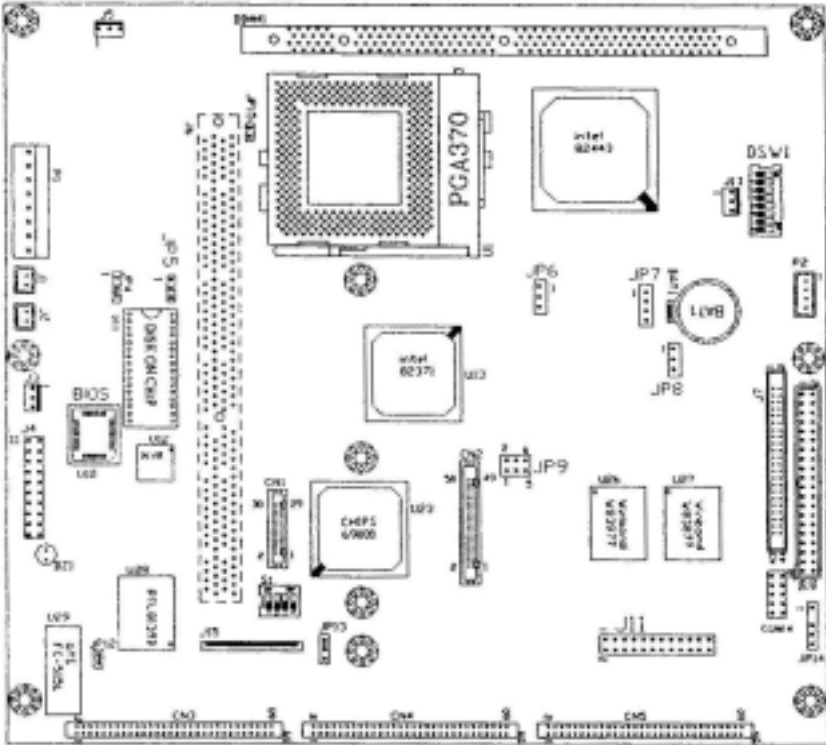

### Switch and Jumpers:



JP5: DiskOnChip BIOS Expansion Address Select

JP6: Clear CMOS Content



JP7: External Battery Connector

J11: RS232/422/485 (COM2) Selection

## JP5: DiskOnChip BIOS Expansion Address Select

| JP5   | Address               |
|---|-----------------------|
|  | D0000-D7FFF           |
|  | D8000-DFFFF (Default) |

## JP6: Clear CMOS Content

| JP6   | Setting                 | Function           |
|---|-------------------------|--------------------|
|  | Pin 2-3<br>Short/Closed | Clear CMOS Content |
|  | Pin 1-2<br>Short/Closed | Normal Operation   |

Following steps to clear CMOS data.

1. Disconnect the AC power cord.
2. Short JP6 (1-2) and wait for 3 seconds.
3. Short JP6- (2-3) and replace the AC power cord.
4. Turn on the system.

## JP7: External Battery Connector

You can connect an external battery by setting JP7 to maintain the information stored in the CMOS RAM in case of the built-in battery malfunctions.

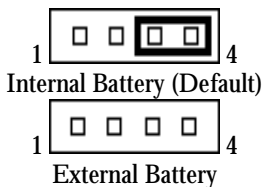

| Pin # | Signal Name |
|-------|-------------|
| 1     | Vcc         |
| 2     | N.C.        |
| 3     | Battery GND |
| 4     | Ground      |

## J11: RS232/422/485 (COM2) Selection

COM1 is reserved for RS-232.

COM2 is selectable for RS-232, RS-422 and RS-485.

The following table describes the connector's jumper settings.

| COM2 Function               | RS-232  | RS-422  | RS-485   |
|-----------------------------|---|---|--|
| Jumper Setting (pin closed) | all jumpers open  | 1-2<br>3-4<br>5-6<br>7-8<br>11-12<br>15-16<br>17-18<br>19-20<br>23-24   | 1-2<br>3-4<br>5-6<br>7-8<br>9-10<br>11-12<br>13-14<br>15-16<br>17-18<br>19-20<br>21-22   |
| Jumper Illustration         | <p>Diagram showing 12 jumper positions for RS-232. Each position consists of two adjacent pins. All boxes are empty, indicating all jumpers are open.</p> | <p>Diagram showing 12 jumper positions for RS-422. The boxes for pairs (1,2), (3,4), (5,6), (7,8), (11,12), (15,16), (17,18), (19,20), and (23,24) are shaded, indicating they are closed. All other boxes are empty.</p> | <p>Diagram showing 12 jumper positions for RS-485. The boxes for pairs (1,2), (3,4), (5,6), (7,8), (9,10), (11,12), (13,14), (15,16), (17,18), (19,20), and (21,22) are shaded, indicating they are closed. All other boxes are empty.</p> |

## Chapter

## 3

**BIOS  
Settings**

This chapter describes the different settings available in the Award BIOS that comes with the EI7BM embedded board. The topics covered in this chapter are as follows:



## Main Menu

---

Once you enter the Award BIOS CMOS Setup Utility, the Main Menu will appear on the screen. The Main Menu allows you to select from several setup functions and two exit choices. Use the arrow keys to select among the items and press <Enter> to accept and enter the sub-menu.



The section below the setup items of the Main Menu displays the control keys for this menu. At the bottom of the Main Menu just below the control keys section, there is another section that displays information about the currently highlighted item in the list.

**NOTE:** *If your computer cannot boot after making and saving system changes with Setup, the Award BIOS supports an override to the CMOS settings that resets your system to its default.*

*We strongly recommend that you avoid making any changes to the chipset defaults. These defaults have been carefully chosen by both Award and your system manufacturer to provide the absolute maximum performance and reliability.*

## Standard CMOS Setup

“Standard CMOS Setup” choice allows you to record some basic hardware configurations in your computer system and set the system clock and error handling. If the Embedded Little Board is already installed in a working system, you will not need to select this option. You will need to run the Standard CMOS option, however, if you change your system hardware configurations, the onboard battery fails, or the configuration stored in the CMOS memory was lost or damaged.



At the bottom of the menu are the control keys for use on this menu. If you need any help in each item field, you can press the <F1> key. It will display the relevant information to help you. The memory display at the lower right-hand side of the menu is read-only. It will adjust automatically according to the memory changed. The following describes each item of this menu.

### Date

The date format is:

**Day:** Sun to Sat  
**Month:** 1 to 12  
**Date:** 1 to 31  
**Year:** 1994 to 2009

To set the date, highlight the “Date” field and use the PageUp/ PageDown or +/- keys to set the current time.

### Time

The time format is: **Hour: 00 to 23**  
**Minute: 00 to 59**  
**Second: 00 to 59**

To set the time, highlight the “Time” field and use the <PgUp>/ <PgDn> or +/- keys to set the current time.

### Primary HDDs / Secondary HDDs

The onboard PCI IDE connectors provide Primary and Secondary channels for connecting up to four IDE hard disks or other IDE devices. Each channel can support up to two hard disks; the first is the “Master” and the second is the “Slave”.

To enter the specifications for a hard disk drive, you must select first a “Type”. There are 45 predefined types and 4 user definable types are for Enhanced IDE BIOS. Type 1 to 49 is predefined. Type “User” is user-definable. For the Primary Master/Slave as well as Secondary Master/Slave, you can select “Auto” under the TYPE and MODE fields. This will enable auto detection of your IDE drives and CD-ROM drive during POST.

Press <PgUp>/<PgDn> to select a numbered hard disk type or type the number and press the <Enter> key. The hard disk will not work properly if you enter incorrect information for this field. If your hard disk drive type is not matched or listed, you can use Type User to define your own drive type manually. If you select Type User, related information is asked to be entered to the following items.

|                                 |  |
|---------------------------------|--|
| <b>CYLS:</b>                    | Number of cylinders                                    |
| <b>HEAD:</b>                    | Number of read/write heads                             |
| <b>PRECOMP:</b>                 | Write precompensation                                  |
| <b>LANDZ:</b>                   | Landing zone   |
| <b>SECTOR:</b>                  | Number of sectors                                      |
| <b>SIZE:</b>                    | Automatically adjust according to the configuration    |
| <b>MODE (for IDE HDD only):</b> | Auto   |
|                                 | Normal (HD < 528MB)                                    |
|                                 | Large (for MS-DOS only)                                |
|                                 | LBA (HD > 528MB and supports Logical Block Addressing) |

**NOTE:** The specifications of your drive must match with the drive table. If your hard disk drive type is not matched or listed, you can use Type User to define your own drive type manually.

**Video**

This field selects the type of video display card installed in your system. You can choose the following video display cards:

|         |  |
|---------|--|
| EGA/VGA | For EGA, VGA, SEGA, SVGA or ZIF monitor adapters.(default)         |
| CGA 40  | Power up in 40 column mode.  |
| CGA 80  | Power up in 80 column mode.  |
| MONO    | For Hercules or MDA, includes high resolution monochrome adapters. |

**Halt On**

This field determines whether or not the system will halt if an error is detected during power up.

|                   |   |
|-------------------|---|
| No errors         | The system boot will not be halted for any error that may be detected.                              |
| All errors        | Whenever the BIOS detects a non-fatal error, the system will be halted and you will be prompted.    |
| All, But Keyboard | The system boot will not be halted for a keyboard error; it will stop for all other errors.         |
| All, But Diskette | The system boot will not be halted for a disk error; it will stop for all other errors.             |
| All, But Disk/Key | The system boot will not be halted for a keyboard or disk error; it will stop for all other errors. |

## BIOS Features Setup

This section allows you to configure and improve your system and allows you to set up some system features according to your preference.



### Virus Warning

This item protects the boot sector and partition table of your hard disk against accidental modifications. If an attempt is made, the BIOS will halt the system and display a warning message. If this occurs, you can either allow the operation to continue or run an anti-virus program to locate and remove the problem. The choice: Enabled, **Disabled** (Default).

**NOTE:** Many disk diagnostic programs, which attempt to access the boot sector table, can cause the virus warning. If you will run such a program, disable the Virus Warning feature.

### CPU Internal Cache / External Cache

These items allow you to enable (speed up memory access) or disable the cache function. The choice: **Enabled** (Default), Disabled.

### CPU L2 Cache ECC Checking

This item allows you to enable/disable CPU L2 Cache ECC checking. The choice: Enable, **Disabled** (Default).

### Quick Power On Self Test

This choice speeds up the Power On Self Test (POST) after you power up the system. If it is set to **Enabled**, BIOS will skip some items. By default, this choice is **Enabled**.

### Boot Sequence

This field determines the drive that the system searches first for an operating system. The options are:

|             |            |            |
|-------------|------------|------------|
| A, C, SCSI  | D, A, SCSI | SCSI, C, A |
| C, A, SCSI  | E, A, SCSI | C only     |
| C, CDROM, A | F, A, SCSI | LS120, C   |
| CDROM, C, A | SCSI, A, C |            |

The default value is ***C,CD-ROM, A.***

### Swap Floppy Drive

This item allows you to determine whether or not to enable the swap Floppy Drive. When enabled, the BIOS swap floppy drive assignments so that Drive A becomes Drive B, and Drive B become Drive A. By default, this field is set to ***Disabled.***

### Boot Up Floppy Seek

When enabled, the BIOS will seek whether or not the floppy drive installed has 40 or 80 tracks. 360K type has 40 tracks while 760K, 1.2M and 1.44M all have 80 tracks. By default, this field is set to ***Enabled.***

### Boot Up NumLock Status

This allows you to activate the NumLock function after you power up the system. By default, the system boots up with ***NumLock On.***

### Gate A20 Option

This field allows you to select how Gate A20 is worked. The Gate A20 is a device used to address memory above 1 MB. By default, this field is set to ***Fast.***

### Typematic Rate Setting

When disabled, continually holding down a key on your keyboard will generate only one instance. When enabled, you can set the two typematic controls listed next. By default, this field is set to ***Enabled.***

### Typematic Rate (Chars/Sec)

When the typematic rate is enabled, the system registers repeated keystrokes speeds. You can select speed range from 6 to 30 characters per second. By default, this item is set to ***30.***

**Typematic Delay (Msec)**

When the typematic rate is enabled, this item allows you to set the time interval for displaying the first and second characters. By default, this item is set to *250msec*.

**Security Option**

This field allows you to limit access to the System and Setup. The default value is *Setup*. When you select *System*, the system prompts for the User Password every time you boot up. When you select *Setup*, the system always boots up and prompts for the Supervisor Password only when the Setup utility is called up.

**PCI/VGA Palette Snoop**

Some display cards that are non-standard VGA may not show colors properly. This field allows you to set whether or not MPEG ISA/VESA VGA Cards can work with PCI/VGA. When this field is enabled, a PCI/VGA can work with an MPEG ISA/VESA VGA card. When this field is disabled, a PCI/VGA cannot work with an MPEG ISA/VESA card. The default value is *Disabled*.

**OS Select for DRAM > 64MB**

This option allows the system to access greater than 64MB of DRAM memory when used with OS/2 that depends on certain BIOS calls to access memory. The default setting is *NON-OS/2*

**Report No FDD For WIN 95**

This option allows Windows 95 to share with other peripherals IRQ6, which is assigned to a floppy disk drive if the drive does not exist. The default value is *Yes*.

**Video BIOS Shadow**

This item allows you to change the Video BIOS location from ROM to RAM. Video Shadow will increase the video speed. By default, this field is set to *Enabled*.

**C8000 - CBFFF Shadow/ DC000 - DFFFF Shadow**

Shadowing a ROM reduces the memory available between 640KB to 1024KB. These fields determine whether or not optional ROM will be copied to RAM. By default, this field is set to *Disabled*.

## Chipset Features Setup

This menu controls the configuration of the embedded board chipset.



### SDRAM RAS-to-CAS Delay

This field lets you insert a timing delay between the CAS and RAS strobe signals, used when DRAM is written to, read from, or refreshed. *Fast* gives faster performance; and *Slow* gives more stable performance. This field applies only when synchronous DRAM is installed in the system.

The choice: 2 (default), 3.

### SDRAM RAS Precharge Time

If an insufficient number of cycles is allowed for the RAS to accumulate its charge before DRAM refresh, the refresh may be incomplete and the DRAM may fail to retain data. *Fast* gives faster performance; and *Slow* gives more stable performance. This field applies only when synchronous DRAM is installed in the system. The choice: 2 (default), 3.

### SDRAM CAS latency Time



When synchronous DRAM is installed, the number of clock cycles of CAS latency depends on the DRAM timing. The choice: 2 (default), 3.

### **SDRAM Precharge Control**

When Enabled, all CPU cycles to SDRAM result in an All Banks Precharge Command on the SDRAM interface. The default setting is ***Enabled***.

### **DRAM Data Integrity Mode**

Select Parity or ECC (error-correcting code), according to the type of installed DRAM. The choice: ECC, Non-ECC (default).

### **System BIOS Cacheable**

Selecting Enabled allows caching of the system BIOS ROM at F0000h-FFFFFh, resulting in better system performance. However, if any program writes to this memory area, a system error may result. The choice: Enable (default), Disabled.

## Power Management Setup

The Power Management Setup allows you to save energy of your system effectively. It will shut down the hard disk and turn off video display after a period of inactivity.



### ACPI function

This item allows you to enable/disable the Advanced Configuration and Power Management (ACPI). The choice: Enable (default), Disable.

### Power Management

This field allows you to select the type of power saving management modes. There are four selections for Power Management.

- |             |  |
|-------------|--|
| Disable     | No power management. (Default)   |
| Min. Saving | Minimum power management.  |
| Max. Saving | Maximum power management. Only available for SL CPU.   |
| User Define | Each of the ranges are from 1 min. to 1hr. Except for HDD Power Down which ranges from 1 min. to 15 min. |

### PM Control by APM

If Advanced Power Management (APM) is installed on your system, selecting Yes gives better power savings. The choice: Yes (default), No.

### Video off Method

This determines the manner in which the monitor is blanked.

**Video off After**

|                          |  |
|--------------------------|--|
| V/H SYNC+Blank (default) | This selection will cause the system to turn off the vertical and horizontal synchronization ports and write blanks to the video buffer. |
| Blank Screen             | This option only writes blanks to the video buffer.  |
| DPMS                     | Initial display power management signaling.  |

As the system moves from lesser to greater power-saving modes, select the mode in which you want the monitor to blank. The choice: NA, Suspend, Standby (default), Doze.

**MODEM Use IRQ**

Name the interrupt request (IRQ) line assigned to the modem (if any) on your system. Activity of the selected IRQ always awakens the system. The choice: NA, 3 (default), 4, 5, 7, 9, 10, 11.

**Doze Mode**

When enabled, and after the set time of system inactivity, the CPU clock will run at a slower speed while all other devices operate at full speed. The choice: Disable (default), 1 Min, 2 Min, 4 Min, 8 Min, 12 Min, 20 Min, 30 Min, 40 Min, 1 Hour.

**Standby Mode**

After the selected period of system inactivity, the fixed disk drive and the video shut off while all other devices still operate at full speed. The choice: Disable (default), 1 Min, 2 Min, 4 Min, 8 Min, 12 Min, 20 Min, 30 Min, 40 Min, 1 Hour.

**Suspend Mode**

When enabled, and after the set time of system inactivity, all devices except the CPU will be shut off. The choice: Disable (default), 1 Min, 2 Min, 4 Min, 8 Min, 12 Min, 20 Min, 30 Min, 40 Min, 1 Hour.

**HDD Power Down**

When enabled, and after the set time of system inactivity, the hard disk drive will be powered down while all other devices remain active. The choice: Disable (default), 1 to 15 Min.

**Throttle Duty Cycle**

When the system enters Doze mode, the CPU clock runs only part of the time. You may select the percent of time that the clock runs. The choice: 12.5%, 25.0%, 37.5%, 50.0%, 62.5% (default), 75.0%.

**PCI/VGA ACT-Monitor**

When Enabled, any video activity restarts the global timer for standby mode. The default value is Disabled.

### Soft-off by PWR-BTTN

When Enabled, turning the system off with the on/off button places the system in a very low-power-usage state, with only enough circuitry receiving power to detect power button activity or [Resume by Ring activity](#).

|                       |  |
|-----------------------|--|
| Instant-Off (default) | This option follows the conventional manner systems perform when power is turned OFF. Instant-Off is a soft power OFF sequence requiring only the switching of the power supply button to OFF.   |
| Delay 4 Sec.          | Upon turning OFF system from the power switch, this option will delay the complete system power OFF sequence by approximately 4 seconds. Within this delay period, system will temporarily enter into Suspend Mode enabling you to restart system at once. |

### PowerOn by Ring

An input signal on the serial Ring Indicator (RI) line (in other words, an incoming call on the modem) awakens the system from a soft off state. The choice: Enabled, Disabled (default).

### Resume by Alarm

When Enabled, you can set the date and time at which the RTC (real-time clock) alarm awakens the system from Suspend mode. The choice: Enable, Disable (default).

### IRQ 8 Break Suspend

You can Enable or Disable monitoring of IRQ8 (the Real Time Clock) so it does not awaken the system from Suspend mode. The choice: Enabled, Disabled (default).

### Reload Global Timer Events

When Enabled, an event occurring on each device listed below restarts the global time for Standby mode.

|                   |                                |
|-------------------|--------------------------------|
| IRQ3-7, 9-15, NMI | The default value is Disabled. |
| Primary IDE 0     | The default value is Disabled. |
| Primary IDE 1     | The default value is Disabled. |
| Secondary IDE 0   | The default value is Disabled. |
| Secondary IDE 1   | The default value is Disabled. |
| Floppy Disk       | The default value is Disabled. |
| Serial Port       | The default value is Enabled.  |
| Parallel Port     | The default value is Disabled. |

## PNP/PCI Configuration

---

This option configures the PCI bus system. All PCI bus systems on the system use INT#, thus all installed PCI cards must be set to this value.



### PNP OS Installed

This field allows you to specify if the operating system installed in your system is plug and play aware. The default value is Yes.

**NOTE:** Operating systems such as DOS, OS/2, and Windows 3.x do not use PnP.

### Resources Controlled by

This PnP BIOS can configure all of the boot and compatible devices automatically. However, this capability needs you to use a PnP operating system such as Windows 95 and Windows 98. The default value is **Auto**.

### Reset Configuration Data

This field allows you to determine whether or not to reset the configuration data. The default value is **Disabled**.



## Integrated Peripherals

This option allows you to determine the configuration of the integrated peripherals including hard disk drives USB, serial and parallel ports.



### IDE HDD Block Mode

This field allows your hard disk controller to use the fast block mode to transfer data to and from your hard disk drive. The default setting is Enabled.

### IDE Primary/Secondary Master/Slave PIO

The four IDE PIO (Programmed Input/Output) fields let you set a PIO mode (0-4) for each of the four IDE devices that the onboard IDE interface supports. Modes 0 through 4 provide successively increased performance. In Auto mode, the system automatically determines the best mode for each device.

### IDE Primary/Secondary Master/Slave UDMA

UDMA (Ultra DMA) is a DMA data transfer protocol that utilizes ATA commands and the ATA bus to allow DMA commands to transfer data at a maximum burst rate of 33 MB/s. When you select Auto in the four IDE UDMA fields (for each of up to four IDE devices that the internal PCI IDE interface supports), the system automatically determines the optimal data transfer rate for each IDE device. The options are Auto (default) and Disabled.

**On-Chip Primary/Secondary PCI IDE**

The integrated peripheral controller contains an IDE interface with support for two IDE channels. Select Enabled to activate each channel separately. The choice is Enabled (default) and Disabled.

**USB Keyboard Support**

Select Enabled if your system contains a Universal Serial Bus (USB) controller and you have a USB keyboard. The choice is Enabled and Disabled (default).

**KBC Input Clock**

The default setting for the keyboard controller input clock is *12 MHz*.

**Onboard FDC Controller**

Select Enabled if your system has a floppy disk controller (FDC) installed on the system board and you wish to use it. If you install an add-in FDC or the system has no floppy drive, select Disabled in this field. The choice is Enabled (default) and Disabled.

**Onboard Serial/Parallel Port**

These fields allow you to select the onboard serial/parallel port and its address. The default values for these ports are: 3BC/IRQ7, 378H/IRQ7 (default), 278/IRQ5 and Disabled.

**Parallel Port Mode**

Select an operating mode for the onboard parallel (printer) port. Select Normal, Compatible, or SPP unless you are certain your hardware and software both support one of the other available modes. The choice is SPP, EPP, ECP, ECP+EPP (default).

**ECP Mode Use DMA**

Select a DMA channel for the port. The choice is 1, 3 (default).

**EPP Mode Select**

Select EPP port type 1.7 or 1.9. The default setting is 1.9.

**PWRON After PWR-Fail**

The choice is on (default), Former-Sts, off.

**Onboard Serial Port**

Select a logical COM port name and matching address for the first and second serial ports. Select an address and corresponding interrupt for the



first and second serial ports. The choice is Auto, Disable, 3F8/IRQ4, 2F8/IRQ3, 3E8/IRQ4, 2E8/IRQ3.

Onboard Serial Port 1 default setting is 3F8/IRQ4.

Onboard Serial Port 1 default setting is 2F8/IRQ3.

Onboard Serial Port 1 default setting is 3E8H.

Onboard Serial Port 1 default setting is 2E8H.

#### **UART Mode Select**

The choice is Normal (default), IrDA, ASKIR.

#### **UART2 Duplex Mode**

In an infrared port mode, this field appears. Full-duplex mode permits simultaneous two-direction transmission. Half-duplex mode permits transmission in one direction only at a time. Select the value required by the IR device connected to the IR port. The choice is Half (default), Full.

#### **RXD, TXD Active**

The choice is Hi,Lo (default), Lo,Hi, Lo,Lo, Hi,Hi.

#### **IR Transmission delay**

Full-duplex mode permits simultaneous two-direction transmission.

Half-duplex mode permits transmission in one direction only at a time. If no infrared port is present in the system, select Disabled. The default setting is Enabled.

## Supervisor / User Password

These two options set the system password. *Supervisor Password* sets a password that will be used to protect the system and Setup utility. *User Password* sets a password that will be used exclusively on the system. To specify a password, highlight the type you want and press <Enter>. The **Enter Password:** message prompts on the screen. Type the password, up to eight characters in length, and press <Enter>. The system confirms your password by asking you to type it again. After setting a password, the screen automatically returns to the main screen.

To disable a password, just press the <Enter> key when you are prompted to enter the password. A message will confirm the password to be disabled. Once the password is disabled, the system will boot and you can enter Setup freely.



### IDE HDD Auto Detection

This option detects the parameters of an IDE hard disk drive, and automatically enters them into the Standard CMOS Setup screen.



Up to four IDE drives can be detected, with parameters for each appearing in sequence inside a box. To accept the displayed entries, press the Y key; to skip to the next drive, press the N key. If you accept the values, the parameters will appear listed beside the drive letter on the screen.

## Save & Exit Setup

This allows you to determine whether or not to accept the modifications. Typing “Y” quits the setup utility and saves all changes into the CMOS memory. Typing “N” brings you back to Setup utility.



## Exit Without Saving



Press <Exit> on this item asks for confirmation:

Quit Without Saving (Y/N)?

This allows you to exit Setup without storing in CMOS any change. The previous selections remain in effect. This exits the Setup utility and restarts your computer.

Chapter

4

**Appendix**

## LCD Panel Configuration

Only for AMB-2051HT/HTT series, AMB-2053HT/HTT series, AMB-2021HTT-C1, AMB-2021HTT-C1, AMB-2023HT-C1 and AMB-2023HTT-C3 products.

If you want to use the 50-Pin cable for external panel, please set the CMOS option like this:

In Standard CMOS Setup



If your panel doesn't work with external, please set the CMOS option like this:

In Standard CMOS Setup



Select **AMB-2212 External** in the panel option

If your panel doesn't work with external, please set the CMOS option like this:



In Standard CMOS Setup

|   |   |
|---|---|
| AMB-2021HT-C1,<br>AMB-2021HTT-C1,<br>AMB-2023HT-C1,<br>AMB-2023HTT-C3 | Select <b>AMB-2212 Internal</b> in the panel option |
| AMB-2051HT/HTT series<br>AMB-2053HT/HTT series                        | Select <b>AMB-2215 Internal</b> in the panel option |

