

AEC-6625

Fanless Embedded Controller

Intel® Core™ i7/i5/Celeron® Processor

Gigabit Ethernet, 6 USB, 4 COM

1 VGA, 1 DVI-D

Copyright Notice

This document is copyrighted, 2014. All rights are reserved. The original manufacturer reserves the right to make improvements to the products described in this manual at any time without notice.

No part of this manual may be reproduced, copied, translated, or transmitted in any form or by any means without the prior written permission of the original manufacturer. Information provided in this manual is intended to be accurate and reliable. However, the original manufacturer assumes no responsibility for its use, or for any infringements upon the rights of third parties that may result from its use.

The material in this document is for product information only and is subject to change without notice. While reasonable efforts have been made in the preparation of this document to assure its accuracy, AAEON assumes no liabilities resulting from errors or omissions in this document, or from the use of the information contained herein.

AAEON reserves the right to make changes in the product design without notice to its users.

Acknowledgments

All other products' name or trademarks are properties of their respective owners.

- Award is a trademark of Award Software International, Inc.
- CompactFlash™ is a trademark of the Compact Flash Association.
- Microsoft Windows® is a registered trademark of Microsoft Corp.
- Intel®, Core™ are trademarks of Intel Corporation.
- PC/AT, PS/2, and VGA are trademarks of International Business Machines Corporation.

All other product names or trademarks are properties of their respective owners.

Packing List

Before you begin operating your PC, please make sure that the following materials are enclosed:

- 1 AEC-6625 Embedded Controller
- 2 Wallmount Brackets
- 1 Screw Package
- 1 RAM Thermal Pad (60mm x 25mm x 3mm)
- 1 DVD-ROM for manual (in PDF format) and drivers

If any of these items should be missing or damaged, please contact your distributor or sales representative immediately.

Safety & Warranty

1. Read these safety instructions carefully.
2. Keep this user's manual for later reference.
3. Disconnect this equipment from any AC outlet before cleaning. Do not use liquid or spray detergents for cleaning. Use a damp cloth.
4. For pluggable equipment, the power outlet must be installed near the equipment and must be easily accessible.
5. Keep this equipment away from humidity.
6. Put this equipment on a firm surface during installation. Dropping it or letting it fall could cause damage.
7. The openings on the enclosure are for air convection. Protect the equipment from overheating. **DO NOT COVER THE OPENINGS.**
8. Make sure the voltage of the power source is correct before connecting the equipment to the power outlet.
9. Position the power cord so that people cannot step on it. Do not place anything over the power cord.
10. All cautions and warnings on the equipment should be noted.
11. If the equipment is not used for a long time, disconnect it from the power source to avoid damage by transient over-voltage.
12. Never pour any liquid into an opening. This could cause fire or electrical shock.
13. Never open the equipment. For safety reasons, only qualified service personnel should open the equipment.
14. If any of the following situations arises, get the equipment checked by service personnel:
 - a. The power cord or plug is damaged.
 - b. Liquid has penetrated into the equipment.
 - c. The equipment has been exposed to moisture.

- d. The equipment does not work well, or you cannot get it to work according to the user's manual.
 - e. The equipment has been dropped and damaged.
 - f. The equipment has obvious signs of breakage.
15. DO NOT LEAVE THIS EQUIPMENT IN AN ENVIRONMENT WHERE THE STORAGE TEMPERATURE IS BELOW -20°C (-4°F) OR ABOVE 70°C (158°F). IT MAY DAMAGE THE EQUIPMENT.

FCC

Warning!



This device complies with Part 15 FCC Rules. Operation is subject to the following two conditions: (1) this device may not cause harmful interference, and (2) this device must accept any interference received including interference that may cause undesired operation.

Caution:

There is a danger of explosion if the battery is incorrectly replaced. Replace only with the same or equivalent type recommended by the manufacturer. Dispose of used batteries according to the manufacturer's instructions and your local government's recycling or disposal directives.

China RoHS Requirements
产品中有毒有害物质或元素名称及含量
AAEON Boxer/ Industrial System

部件名称	有毒有害物质或元素					
	铅 (Pb)	汞 (Hg)	镉 (Cd)	六价铬 (Cr(VI))	多溴联苯 (PBB)	多溴二苯醚 (PBDE)
印刷电路板 及其电子组件	×	○	○	○	○	○
外部信号 连接器及线材	×	○	○	○	○	○
外壳	×	○	○	○	○	○
中央处理器 与内存	×	○	○	○	○	○
硬盘	×	○	○	○	○	○
电源	×	○	○	○	○	○

O: 表示该有毒有害物质在该部件所有均质材料中的含量均在 SJ/T 11363-2006 标准规定的限量要求以下。

X: 表示该有毒有害物质至少在该部件的某一均质材料中的含量超出 SJ/T 11363-2006 标准规定的限量要求。

备注:
 一、此产品所标示之环保使用期限，系指在一般正常使用状况下。
 二、上述部件物质中央处理器、内存、硬盘、电源为选购品。

Contents

Chapter 1 General Information

1.1 Introduction.....	1-2
1.2 Features	1-3
1.3 Specifications	1-4

Chapter 2 Hardware Installation

2.1 Dimension and I/O of AEC-6625.....	2-2
2.2 Location of Connectors and Jumpers of the Main Board	2-6
2.3 List of Jumpers	2-8
2.4 List of Connectors	2-8
2.5 RS-232/422/485 Serial Port Connector (COM 2).....	2-10
2.6 CompactFlash™ Card Installation	2-11
2.7 Hard Disk Drive (HDD) Installation.....	2-12
2.8 Memory Card Installation	2-18
2.9 Wallmount Kit Installation	2-20

Chapter 3 Award BIOS Setup

3.1 System Test and Initialization.	3-2
3.2 Award BIOS Setup	3-3

Chapter 4 Driver Installation

4.1 Installation	4-3
------------------------	-----

Appendix A Programming The Watchdog Timer

A.1 ProgrammingA-2
A.2 ITE8781 Watchdog Timer Initial ProgramA-6

Appendix B RAID & AHCI Settings

B.1 Setting RAIDB-2
B.2 Setting AHCIB-12

Contents

Chapter 1 General Information

1.1 Introduction.....	1-2
1.2 Features	1-3
1.3 Specifications	1-4

Chapter 2 Hardware Installation

2.1 Dimension and I/O of AEC-6625.....	2-2
2.2 Location of Connectors and Jumpers of the Main Board	2-6
2.3 List of Jumpers	2-8
2.4 List of Connectors	2-8
2.5 RS-232/422/485 Serial Port Connector (COM 2).....	2-10
2.6 CompactFlash™ Card Installation	2-11
2.7 Hard Disk Drive (HDD) Installation.....	2-12
2.8 Memory Card Installation	2-18
2.9 Wallmount Kit Installation.....	2-20

Chapter 3 Award BIOS Setup

3.1 System Test and Initialization.	3-2
3.2 Award BIOS Setup	3-3

Chapter 4 Driver Installation

4.1 Installation	4-3
------------------------	-----

Appendix A Programming The Watchdog Timer

A.1 Programming	A-2
A.2 ITE8781 Watchdog Timer Initial Program	A-6

Appendix B RAID & AHCI Settings

B.1 Setting RAID	B-2
B.2 Setting AHCI	B-12

Chapter

1

**General
Information**

1.1 Introduction

The newest Boxer series AEC-6625 has been introduced by AAeon and it utilizes Intel® P4500 1.86 GHz processor. This condensed Embedded Controller is a fanless controller with the latest Intel® processor and chipset. The cutting-edge technology has been equipped to the AEC-6625 to satisfy the versatile demands of Factory Automation, Vehicle and Marine.

The AEC-6625 offers low power consumption system that while operating in ambient with airflow temperatures ranging from -20° to 60°C. The AEC-6625 is a standalone high performance controller designed for long-life operation and with high reliability. It can replace traditional methods and become the mainstream controller for the multimedia entertainment market. If you are looking for a multifunctional embedded controller, the AEC-6625 is your best choice to fit into your vital applications.

1.2 Features

- Intel® QM57 Chipset
- Supports DVI-D x 1, VGA x 1
- Up To COM x 4
- Up To USB x 6
- Fanless Operation
- Gigabit Ethernet x 2
- SATA Hard Disk Drive Bay
- ATX/ACPI Power Mode
- PCI-104 Expansion (Optional)

1.3 Specifications

CPU		Intel® P4500 1.86 GHz
Chipset		Intel® QM57
System Memory		204-pin DDR3 SODIMM x 1, Max. 4 GB
Display Interface	VGA	D-Sub 15 x 1, shared system memory up to 512 MB
	DVI	DVI-D x 1
	Others	—
Storage Device	SSD	CompactFlash™ Slot
	HDD	2.5" SATA Slim Hard Disk Drive Bay x 1 (TF-AEC-6625-A3M-1010); Optional Dual 2.5" Slim Hard Disk Drive Kit; Optional 2.5" Slim Hard Disk Drive + Slim DVD-ROM Kit
Network	LAN	Gigabit Ethernet, RJ-45 x 2
	Wireless	—
Front I/O	USB Host	USB2.0 x 2 (TF-AEC-6625-A2M/A3M-1010)
	LAN	—
	Serial Port	—
	DIO	—
	Audio	—
	KB/MS	—
	Others	Power Switch x 1, Reset Button x 1, Power inlet x 1
Rear I/O	USB Host	USB2.0 x 4

	LAN	RJ-45 x 2
	Serial Port	RS-232/422/485 x 1 (COM 2), RS-232 x 1 (TF-AEC-6625-A1M-1010); RS-232 x 3 (TF-AEC-6625-A2M/A3M-1010)
	DIO	—
	Audio	Line-in/ Line-out x 1
	KB/MS	—
	Others	DVI x 1, VGA x 1
Expansion	PCIe [x1]	—
	PCI	—
	Mini Card	1
	Mini PCI	—
	Others	PCI-104 x 1 (TF-AEC-6625-A3M-1010 only)
Indicator	Front	Power LED x 1, HDD LED x 1
	Rear	—
Power Requirement		DC-in 9~30V
Power Consumption		Intel® P4500, 1.25A @ 30V
System Cooling		Passive Cooling
Mounting		Wallmount
Operating Temperature		Ambient with Airflow: -4°F ~140°F (-20°C~60°C) No Airflow -4°F ~122°F (-20°C~50°C)
Storage Temperature		-4°F ~158°F (-20°C~70°C)

Anti-Vibration		5 g rms/5~500 Hz/ random operation (CFD); 1 g rms/5~500 Hz/ random operation (HDD)
Anti-Shock		50 G peak acceleration (11 msec, duration)-CFD 20 G peak acceleration (11 msec, duration)-HDD
MTBF		—
Certification	EMC	CE/FCC Class A
	Safety	—
Dimension		8.35" (W) x 2.52" (H) x 6.22" (D) (212mm x 64mm x 158mm)
Gross Weight		10.34 lb (4.7 kg)
Note		Windows [®] XP Embedded, Windows [®] XP, Windows [®] 7 support

Chapter

2

Hardware Installation

2.1 Dimension and I/O of AEC-6625

AEC-6625-A1/A2

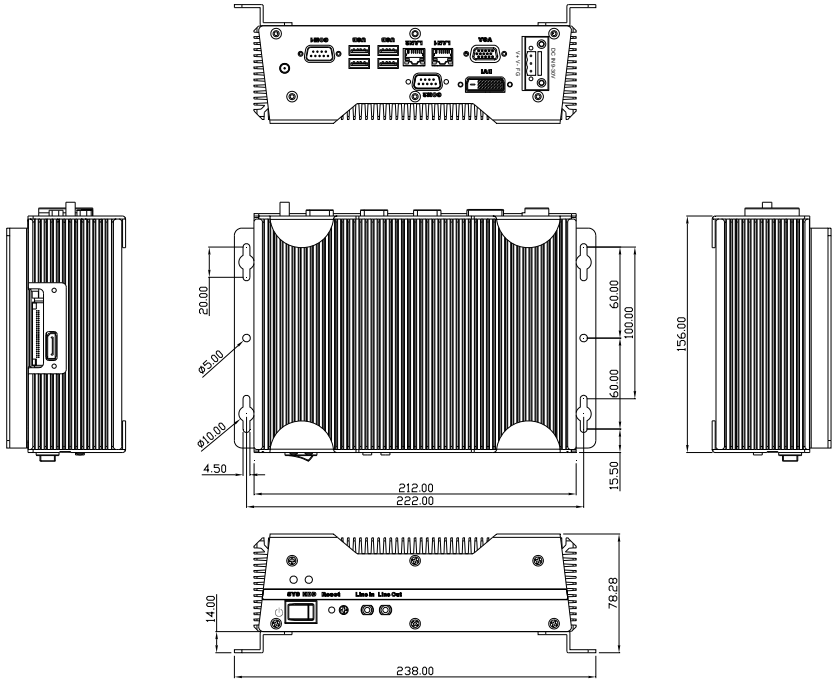

Connector of AEC-6625-A1 (Front)

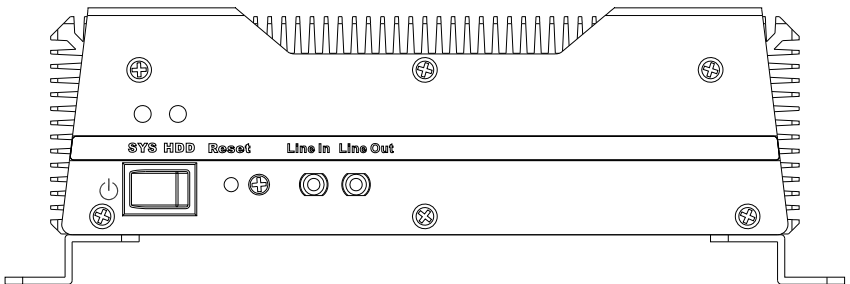

Connector of AEC-6625-A1 (Rear)

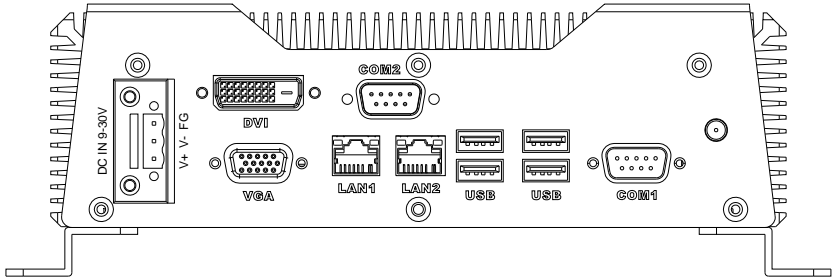

Connector of AEC-6625-A2 (Front)

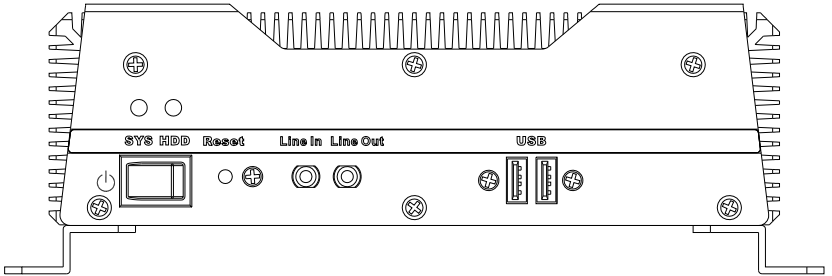

Connector of AEC-6625-A2 (Rear)

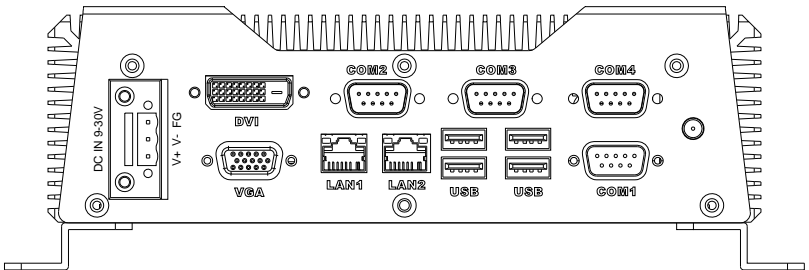

AEC-6625-A3

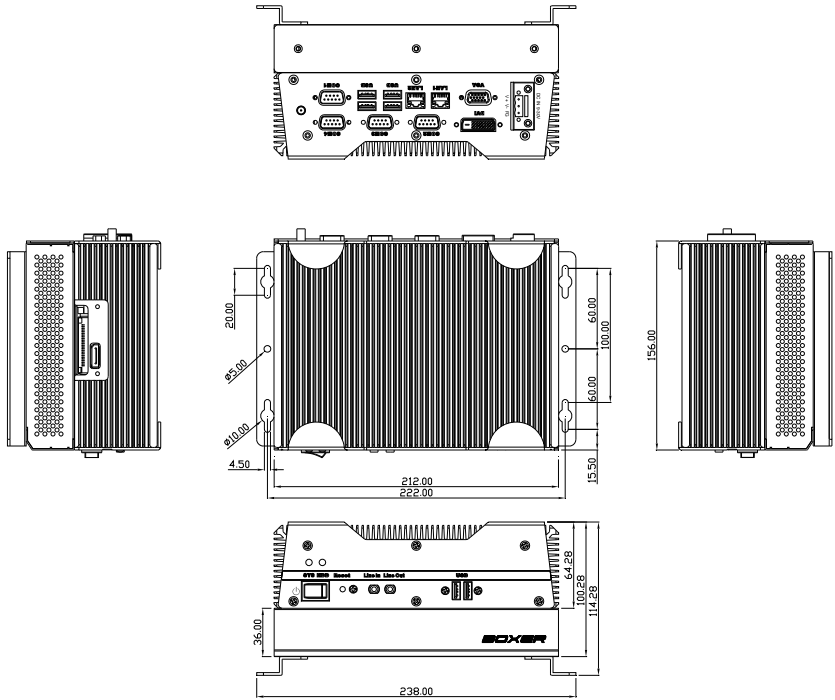

Connectors of AEC-6625-A3 (Front)

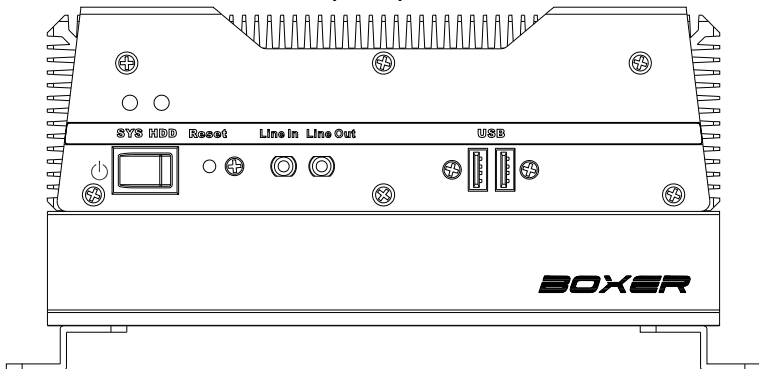

Connectors of AEC-6625-A3 (Rear)

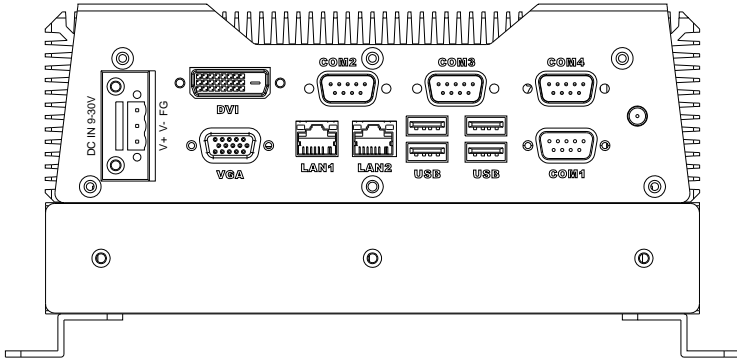

2.2 Connectors and Jumpers of The Main Board

Component Side

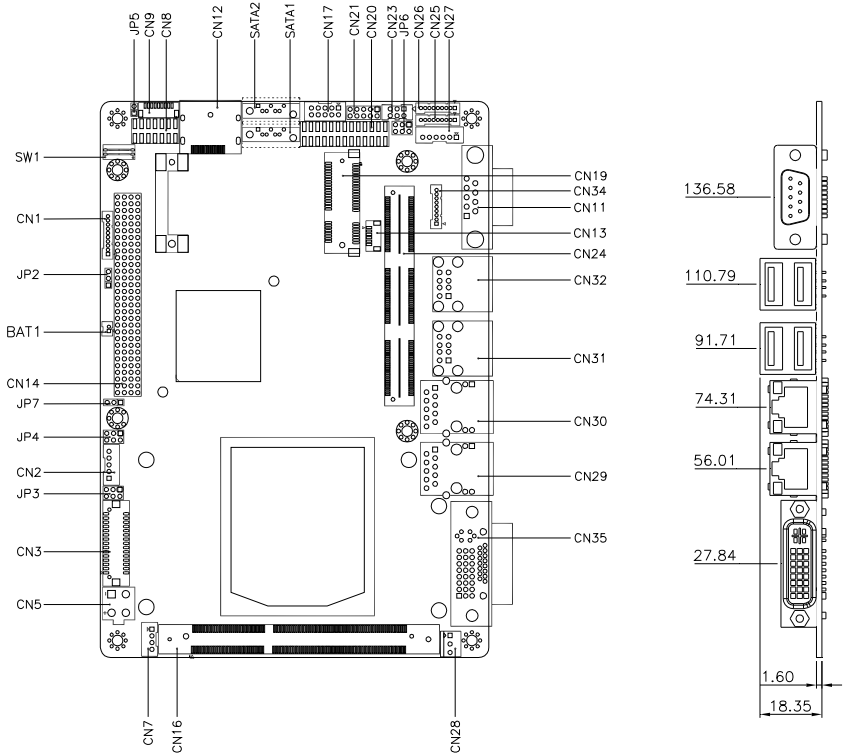

Solder Side

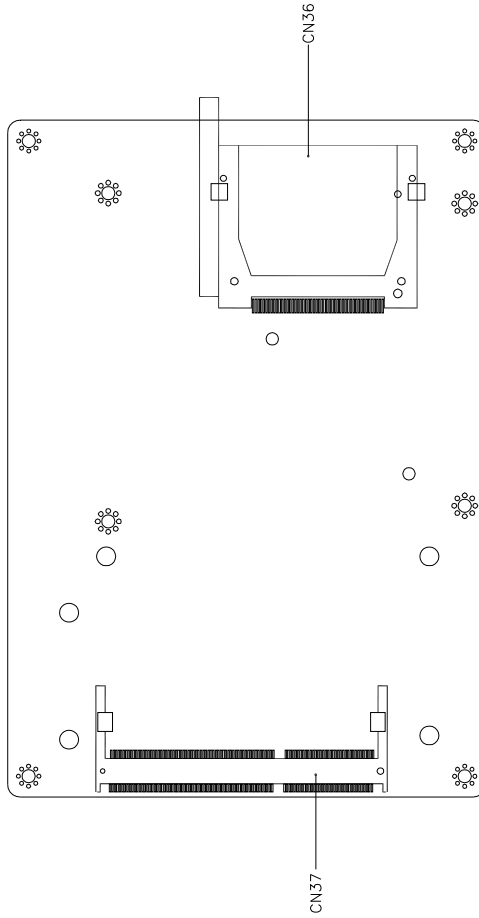

2.3 List of Jumpers

The board has a number of jumpers that allow you to configure your system to suit your application.

The table below shows the function of each of the board's jumpers:

Label	Function
JP2	PCI-104 I/O Voltage Selection
JP3-1	LCD Inverter/Backlight Voltage Selection
JP3-2	LVDS LCD Voltage Selection
JP4-1	Clear CMOS
JP4-2	Clear ME ROM
JP5	Touch Screen 4/5/8-wire Mode Selection
JP6	COM2 RI/+5V/+12V Selection
SW1	AT/ATX Power Mode Selection

2.4 List of Connectors

The board has a number of connectors that allow you to configure your system to suit your application. The table below shows the function of each board's connectors:

Label	Function
CN1	Front Panel Connector
CN2	LCD Inverter/Backlight Connector
CN3	Dual Channel LVDS LCD Connector
CN5	+12V DC Power Input Connector
CN7	+5V/+12V Power Output Connector
CN8	Audio Connector

CN9	Touch Panel Connector
CN11	RS-232 Serial Port 1 Connector
CN12	Display Port Connector
CN13	UIM Connector
CN14	PCI-104 Connector
CN16,CN37	DDR3 SODIMM Slot
CN17,CN31,CN32	USB Connector
CN19	PCI Express Mini Card Connector
CN20	LPT Port Connector
CN21	Digital I/O Connector
CN23	PS2 Keyboard/Mouse Connector
CN24	PCIe/104 Connector
CN25	RS-232 Serial Port 4 Connector
CN26	RS-232 Serial Port 3 Connector
CN27	External SMBUS and PS_ON# Connector
CN28	Fan Connector
CN29, CN30	10/100/1000Base-TX Ethernet Connector
CN34	RS-232/422/485 Serial Port 2 Connector
CN35	DVI-I Connector
CN36	CompactFlash™ Slot

2.5 RS-232/422/485 Serial Port Connector (COM 2)

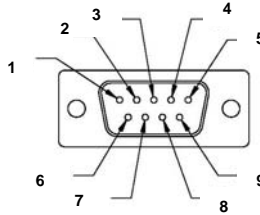

Pin	Signal	Pin	Signal
1	DCD (422TXD-/485DATA-)	2	RXD (422RXD+)
3	TXD (422TXD+/485DATA+)	4	DTR (422RXD-)
5	GND	6	DSR
7	RTS	8	CTS
9	RI/+5V/+12V Selection		

COM2 RI/+5V/+12V Selection (JP6)

Pin	Signal
1-2	+12V
3-4	RI (Default)
5-6	+5V

2.6 CompactFlash™ Card Installation

Step 1: Unfasten the two screws of the CompactFlash™ Bracket

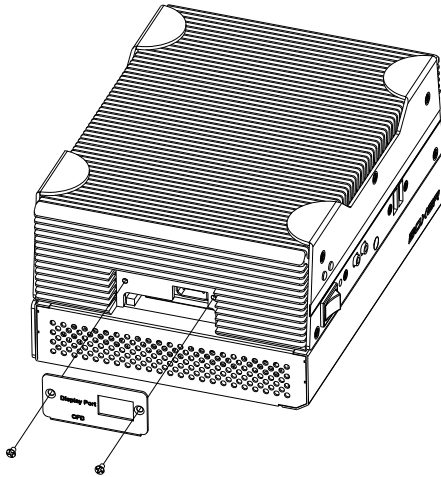

Step 2: Insert the CompactFlash™ and finish the installation

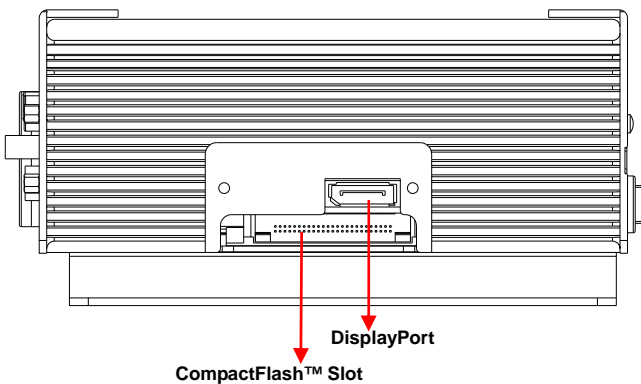

2.7 Hard Disk Drive (HDD) Installation

For A1/A2 Version

Step 1: Get the HDD and HDD Bracket ready. Fasten the four screws to fix the HDD and HDD bracket

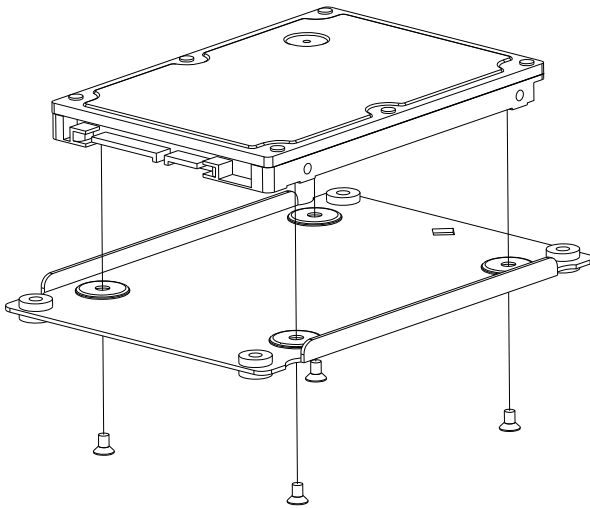

Step 2: Connect the SATA cable to the HDD

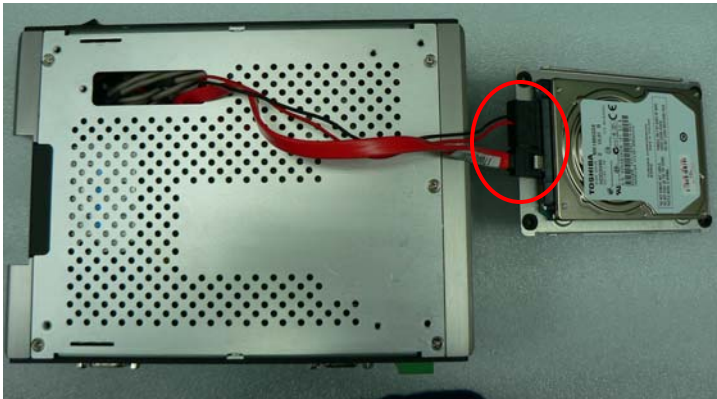

Step 3: Fasten the four screws to fix the HDD bracket with the bottom case of AEC-6625



Step 4: Close the bottom cover of the AEC-6625 and fasten the screw



Step 5: Fasten the screw to finish the installation



For A3 Version

Step 1: Unfasten the four screws to release the brackets from the AEC-6625

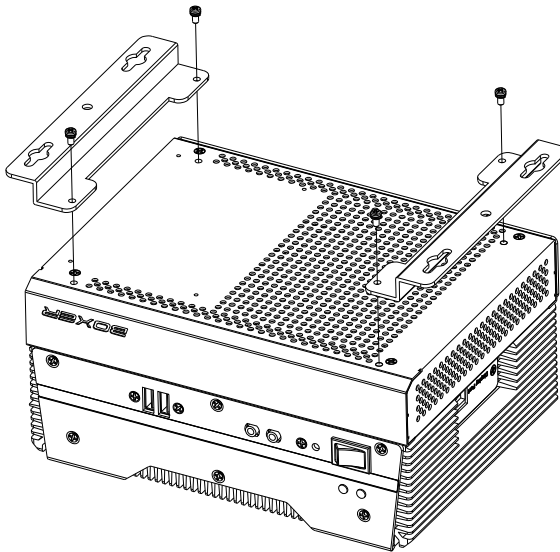

Step 2: Unfasten the six screws to release the bottom case of the AEC-6625

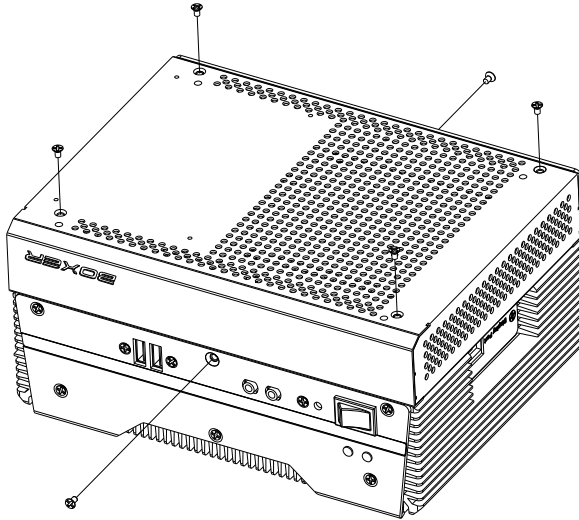

Step 3: Get the HDD and HDD Bracket ready. Fasten the four screws to fix the HDD and HDD bracket

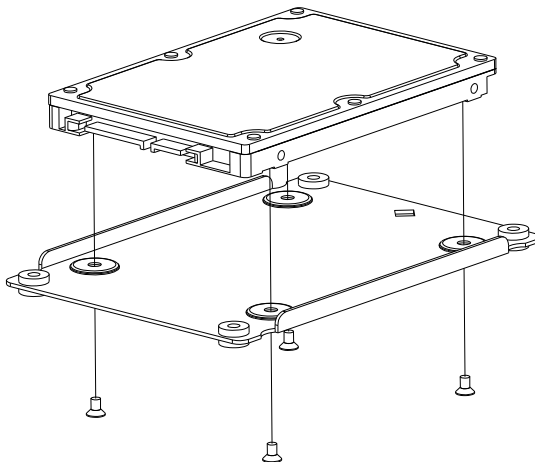

Step 4: Fasten the four screws to fix the HDD bracket with the bottom case of AEC-6625

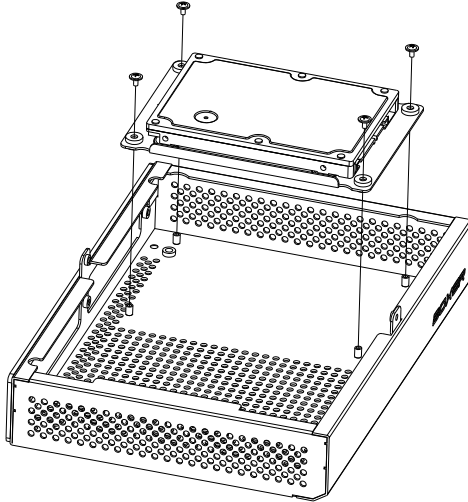

Step 5: Get the PCI-104 card ready and fasten the four screws to install the PCI-104 card

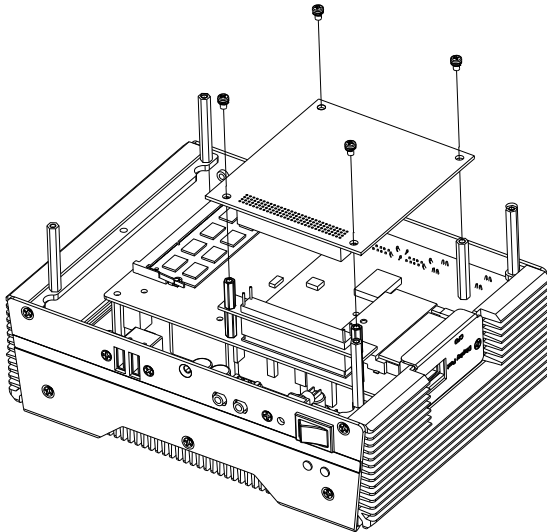

Step 6: Close the bottom case of AEC-6625 and fasten the six screws

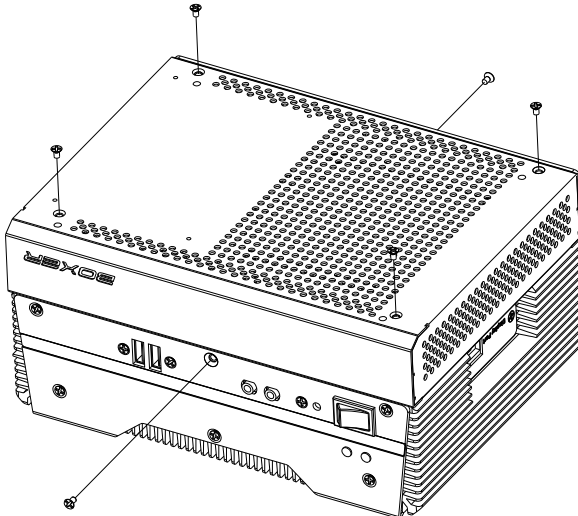

Step 7: Fasten the four screws to install the two bracket

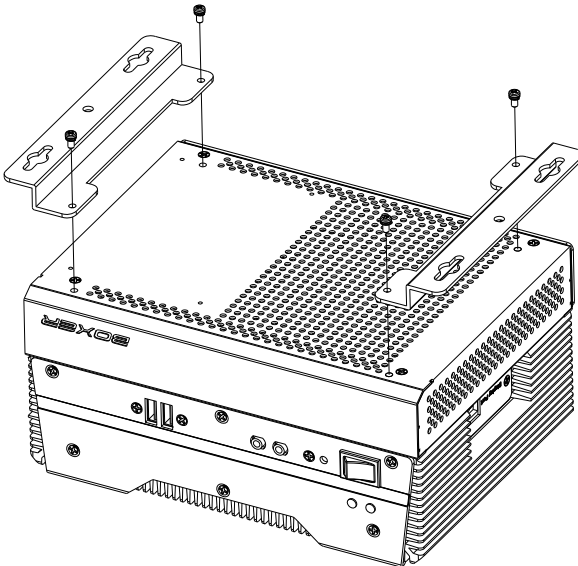

2.8 Memory Card Installation

Step 1: Unfasten the four screws to release the brackets from the AEC-6625

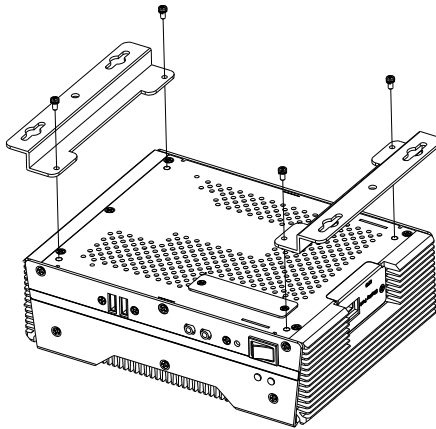

Step 2: Unfasten the five screws to release the bottom cover of the AEC-6625

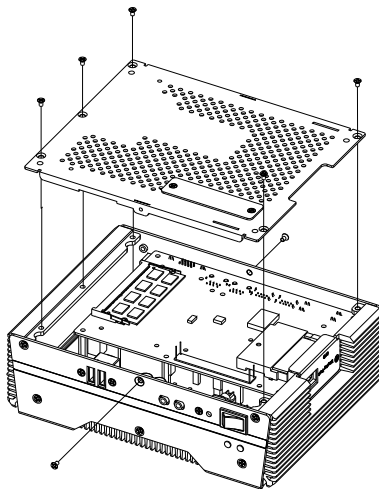

Step 3: Insert the RAM at 30-degree angle to the memory slot and press

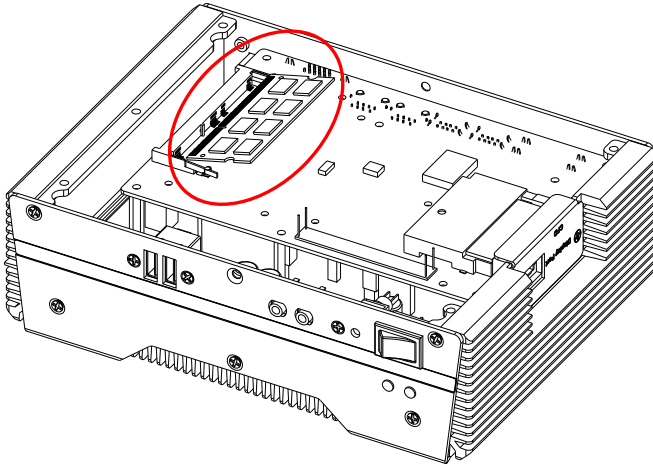

Step 3: Adhere the heat spreading pad to the RAM



2.9 Wallmount Kit Installation

Get the brackets ready and fasten appropriate four screws on each bracket. After fastening the two brackets on the bottom lid of AEC-6625, the wallmount kit installation has been finished.

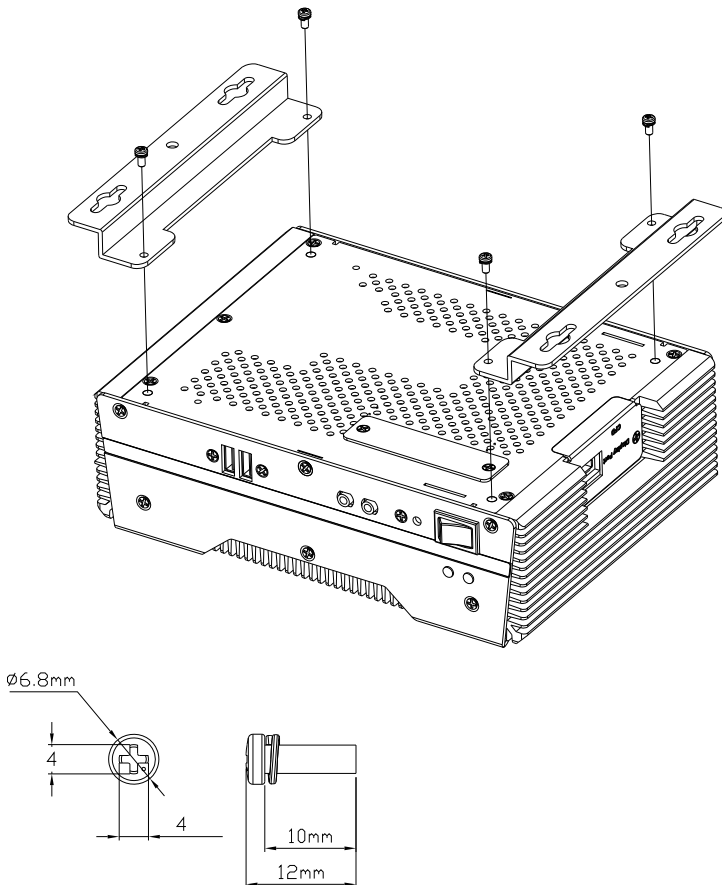

Screw.6#-32*10mm
x4Pcs/6Pcs(Max)

Chapter

3

**Award
BIOS Setup**

3.1 System Test and Initialization

These routines test and initialize board hardware. If the routines encounter an error during the tests, you will either hear a few short beeps or see an error message on the screen. There are two kinds of errors: fatal and non-fatal. The system can usually continue the boot up sequence with non-fatal errors. Non-fatal error messages usually appear on the screen along with the following instructions:

Press <F1> to RESUME

Write down the message and press the F1 key to continue the boot up sequence.

System configuration verification

These routines check the current system configuration against the values stored in the CMOS memory. If they do not match, the program outputs an error message. You will then need to run the BIOS setup program to set the configuration information in memory.

There are three situations in which you will need to change the CMOS settings:

1. You are starting your system for the first time
2. You have changed the hardware attached to your system
3. The CMOS memory has lost power and the configuration information has been erased.

The AEC-6625 CMOS memory has an integral lithium battery backup for data retention. However, you will need to replace the complete unit when it finally runs down.

3.2 Award BIOS Setup

Awards BIOS ROM has a built-in Setup program that allows users to modify the basic system configuration. This type of information is stored in battery-backed CMOS RAM so that it retains the Setup information when the power is turned off.

Entering Setup

Power on the computer and press immediately. This will allow you to enter Setup.

Standard CMOS Features

Use this menu for basic system configuration. (Date, time, IDE, etc.)

Advanced BIOS Features

Use this menu to set the advanced features available on your system.

Advanced Chipset Features

Use this menu to change the values in the chipset registers and optimize your system performance.

Integrated Peripherals

Use this menu to specify your settings for integrated peripherals. (keyboard, mouse etc.)

Power Management Setup

Use this menu to specify your settings for power management. (HDD power down, power on by ring, KB wake up, etc.)

PnP/PCI Configurations

This entry appears if your system supports PnP/PCI.

PC Health Status

Use this menu to set PC Health Status.

Frequency/Voltage Control

Use this menu to specify your settings for auto detect DIMM/PCI clock and spread spectrum.

Load Optimized Defaults

Use this menu to load the BIOS default values that are factory settings for optimal performance system operations. While AWARD has designated the custom BIOS to maximize performance, the factory has the right to change these defaults to meet their needs.

Set Password

Use this menu to set Supervisor Password.

Save and Exit Setup

Save CMOS value changes to CMOS and exit setup.

Exit Without Saving

Abandon all CMOS value changes and exit setup.

You can refer to the "AAEON BIOS Item Description.pdf" file in the DVD for the meaning of each setting in this chapter.

Chapter

4

**Driver
Installation**

The AEC-6625 comes with a DVD-ROM that contains all drivers that you need.

Follow the sequence below to install the drivers:

Step 1 – Install Chipset Driver

Step 2 – Install VGA Driver

Step 3 – Install LAN Driver

Step 4 – Install ME Driver

Step 5 – Install Audio Driver

Step 6 – Install RAID Driver

Please read the following instructions for detailed installations.

4.1 Installation

Insert the AEC-6625 DVD-ROM into the DVD-ROM Drive. And install the drivers from Step 1 to Step 6 in order.

Step 1 – Install Chipset Driver

1. Click on the **Step1-CHIPSET** folder and then double click on the **infinst_autol(9.1.1.1020).exe**
2. Follow the instructions that the window shows
3. The system will help you to install the driver automatically

Step 2 – Install VGA Driver

1. Click on the **Step2 - VGA** folder and select the OS your system is
2. Double click on **Setup.exe** file located in each OS folder
3. Follow the instructions that the window shows
4. The system will help you to install the driver automatically

Step 3 – Install LAN Driver

1. Click on the **Step3 - LAN** folder and double click on **Autorun.exe** file
2. Follow the instructions that the window shows
3. The system will help you to install the driver automatically

Step 4 – Install ME Driver

1. Click on the **Step4 - ME** folder and double click on **Setup.exe** file
2. Follow the instructions that the window shows

3. The system will help you to install the driver automatically

Step 5 – Install AUDIO Driver

1. Click on the **Step5 - AUDIO** folder and double click on **SETUP.exe** file
2. Follow the instructions that the window shows
3. The system will help you to install the driver automatically

Step 6 – Install RAID Driver

Please refer to Appendix B RAID & AHCI Settings

Appendix

A

Programming the Watchdog Timer

A.1 Programming

AEC-6625 utilizes ITE 8781 chipset as its watchdog timer controller. Below are the procedures to complete its configuration and the AAEON initial watchdog timer program is also attached based on which you can develop customized program to fit your application.

Configuring Sequence Description

After the hardware reset or power-on reset, the ITE 8781 enters the normal mode with all logical devices disabled except KBC. The initial state (enable bit) of this logical device (KBC) is determined by the state of pin 121 (DTR1#) at the falling edge of the system reset during power-on reset.

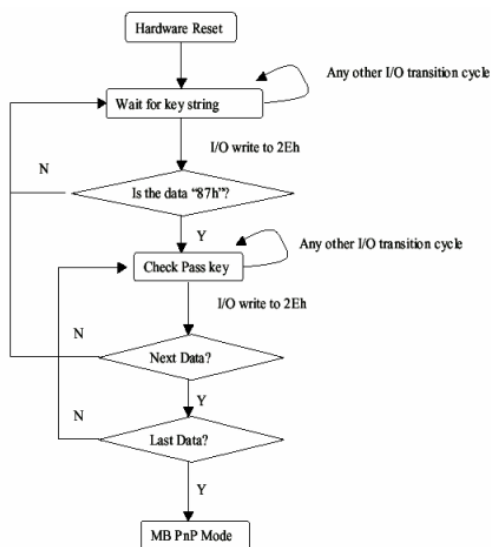

There are three steps to complete the configuration setup: (1) Enter the MB PnP Mode; (2) Modify the data of configuration registers; (3) Exit the MB PnP Mode. Undesired result may occur if the MB PnP Mode is not exited normally.

(1) Enter the MB PnP Mode

To enter the MB PnP Mode, four special I/O write operations are to be performed during Wait for Key state. To ensure the initial state of the key-check logic, it is necessary to perform four write operations to the Special Address port (2EH). Two different enter keys are provided to select configuration ports (2Eh/2Fh) of the next step.

	Address Port	Data Port
87h, 01h, 55h, 55h:	2Eh	2Fh

(2) Modify the Data of the Registers

All configuration registers can be accessed after entering the MB PnP Mode. Before accessing a selected register, the content of Index 07h must be changed to the LDN to which the register belongs, except some Global registers.

(3) Exit the MB PnP Mode

Set bit 1 of the configure control register (Index=02h) to 1 to exit the MB PnP Mode.

WatchDog Timer Configuration Registers

LDN	Index	R/W	Reset	Configuration Register or Action
All	02h	W	NA	Configure Control

07h	71h	R/W	00h	Watch Dog Timer Control Register
07h	72h	R/W	001s0000b	Watch Dog Timer Configuration Register
07h	73h	R/W	38h	Watch Dog Timer Time-out Value (LSB) Register
07h	74h	R/W	00h	Watch Dog Timer Time-out Value (MSB) Register

Configure Control (Index=02h)

This register is write only. Its values are not sticky; that is to say, a hardware reset will automatically clear the bits, and does not require the software to clear them.

Bit	Description
7-2	Reserved
1	Returns to the "Wait for Key" state. This bit is used when the configuration sequence is completed.
0	Resets all logical devices and restores configuration registers to their power-on states.

Watch Dog Timer 1, 2, 3 Control Register (Index=71h,81h,91h Default=00h)

Bit	Description
7	WDT Timeout Enable(WTE) 1: Disable. 0: Enable.
6	WDT Reset upon Mouse Interrupt(WRKMI) 0: Disable. 1: Enable.
5	WDT Reset upon Keyboard Interrupt(WRKBI) 0: Disable. 1: Enable.
4	Reserved
3-2	Reserved
1	Force Time-out(FTO) This bit is self-clearing.
0	WDT Status(WS) 1: WDT value reaches 0. 0: WDT value is not 0.

Watch Dog Timer 1, 2, 3 Configuration Register (Index=72h, 82h, 92h Default=001s0000b)

Bit	Description
7	WDT Time-out Value Select 1 (WTVS) 1: Second 0: Minute
6	WDT Output through KRST (Pulse) Enable(WOKE) 1: Enable 0: Disable
5	WDT Time-out value Extra select(WTVES) 1: 64ms x WDT Timer-out value (default = 4s) 0: Determined by WDT Time-out value select 1 (bit 7 of this register)
4	WDT Output through PWROK (Pulse) Enable(WOPE) 1: Enable 0: Disable During LRESET#, this bit is selected by JP7 power-on strapping option
3-0	Select interrupt level^{Note1} for WDT(SIL)

Watch Dog Timer 1,2,3 Time-Out Value (LSB) Register (Index=73h,83h,93h, Default=38h)

Bit	Description
7-0	WDT Time-out Value 7-0(WTV)

Watch Dog Timer 1,2,3 Time-Out Value (MSB) Register (Index=74h,84h,94h Default=00h)

Bit	Description
7-0	WDT Time-out Value 15-8(WTV)

A.2 ITE8781 Watchdog Timer Initial Program

```
.MODEL SMALL
.CODE
Main:
CALL Enter_Configuration_mode
CALL Check_Chip
mov cl, 7
call Set_Logic_Device
;time setting
mov cl, 10 ; 10 Sec
dec al
Watch_Dog_Setting:
;Timer setting
mov al, cl
mov cl, 73h
call Superio_Set_Reg
;Clear by keyboard or mouse interrupt
mov al, 0f0h
mov cl, 71h
call Superio_Set_Reg
;unit is second.
mov al, 0C0H
mov cl, 72h
```

```
call Superio_Set_Reg  
; game port enable  
mov cl, 9  
call Set_Logic_Device
```

```
Initial_OK:  
CALL Exit_Configuration_mode  
MOV AH,4Ch  
INT 21h
```

```
Enter_Configuration_Mode PROC NEAR  
MOV SI,WORD PTR CS:[Offset Cfg_Port]
```

```
MOV DX,02Eh  
MOV CX,04h  
Init_1:  
MOV AL,BYTE PTR CS:[SI]  
OUT DX,AL  
INC SI  
LOOP Init_1  
RET  
Enter_Configuration_Mode ENDP
```

```
Exit_Configuration_Mode PROC NEAR  
MOV AX,0202h
```

CALL Write_Configuration_Data

RET

Exit_Configuration_Mode ENDP

Check_Chip PROC NEAR

MOV AL,20h

CALL Read_Configuration_Data

CMP AL,87h

JNE Not_Initial

MOV AL,21h

CALL Read_Configuration_Data

CMP AL,81h

JNE Not_Initial

Need_Initial:

STC

RET

Not_Initial:

CLC

RET

Check_Chip ENDP

Read_Configuration_Data PROC NEAR

MOV DX,WORD PTR CS:[Cfg_Port+04h]

```
OUT DX,AL
MOV DX,WORD PTR CS:[Cfg_Port+06h]
IN AL,DX
RET
Read_Configuration_Data ENDP
```

```
Write_Configuration_Data PROC NEAR
MOV DX,WORD PTR CS:[Cfg_Port+04h]
OUT DX,AL
XCHG AL,AH
MOV DX,WORD PTR CS:[Cfg_Port+06h]
OUT DX,AL
RET
Write_Configuration_Data ENDP
```

```
Superio_Set_Reg proc near
push ax
MOV DX,WORD PTR CS:[Cfg_Port+04h]
mov al,cl
out dx,al
pop ax
inc dx
out dx,al
ret
Superio_Set_Reg endp.Set_Logic_Device proc near
```

```
Set_Logic_Device    proc    near
push ax
push cx
xchg al,cl
mov cl,07h
call Superio_Set_Reg
pop cx
pop ax
ret
Set_Logic_Device endp
```

```
;Select 02Eh->Index Port, 02Fh->Data Port
Cfg_Port DB 087h,001h,055h,055h
DW 02Eh,02Fh
```

END Main

Note: Interrupt level mapping

0Fh-Dh: not valid

0Ch: IRQ12

.

.

03h: IRQ3

02h: not valid

01h: IRQ1

00h: no interrupt selected

Appendix

B

RAID & AHCI Settings

B.1 Setting RAID

OS installation to setup RAID Mode

Step 1: Copy the files below from "**Driver DVD -> Raid Driver -> F6**

Floppy - x86" to Disk

 F6Readme
文字文件
8 KB

 iaAHCI
安裝資訊
9 KB

 iaStor
安裝資訊
8 KB

 license
文字文件
5 KB

 TXTSETUP.OEM
OEM 檔案
6 KB

 iaAHCI
安全性目錄
9 KB

 iaStor
安全性目錄
8 KB

 iaStor
系統檔案
423 KB

 readme
文字文件
78 KB

Step 2: Connect the USB Floppy (disk with RAID files) to the board



Step 3: The setting procedures "In BIOS Setup Menu"

A: Advanced -> SATA Configuration -> SATA Mode -> RAID Mode

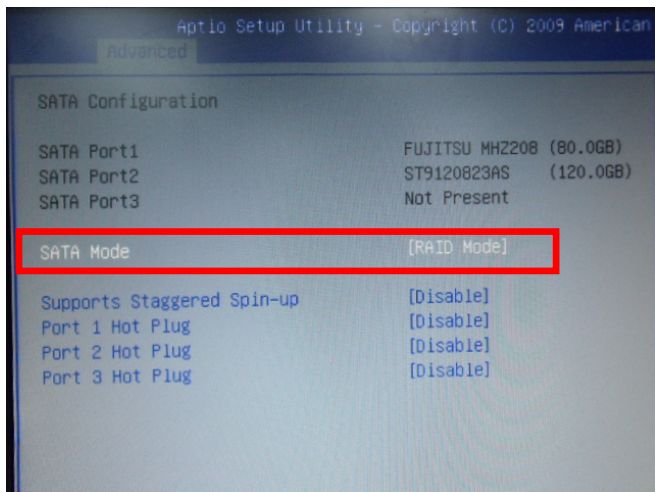

Step 4: The setting procedures "In BIOS Setup Menu"

B: Advanced -> Launch Storage OpROM -> Enabled

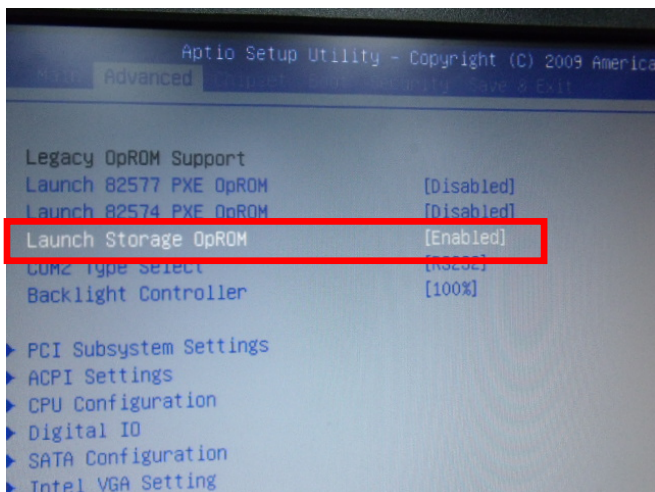

Step 5: The setting procedures "In BIOS Setup Menu"

C: Boot -> Boot Option #1 -> DVD-ROM Type

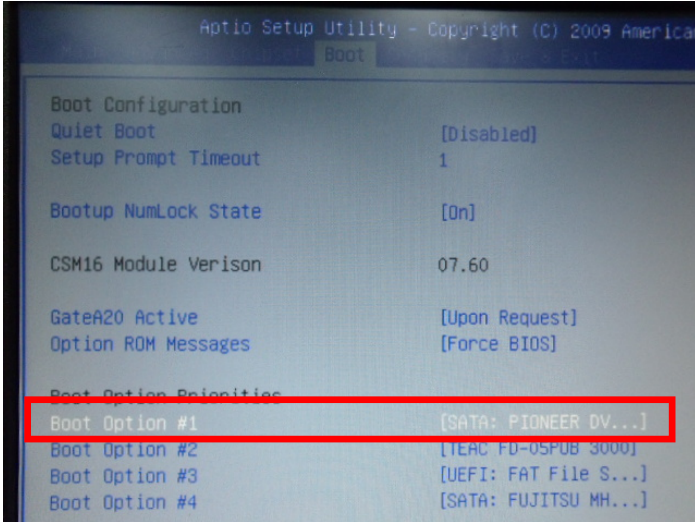

Step 6: The setting procedures "In BIOS Setup Menu"

D: Save & Exit -> Save Changes and Exit

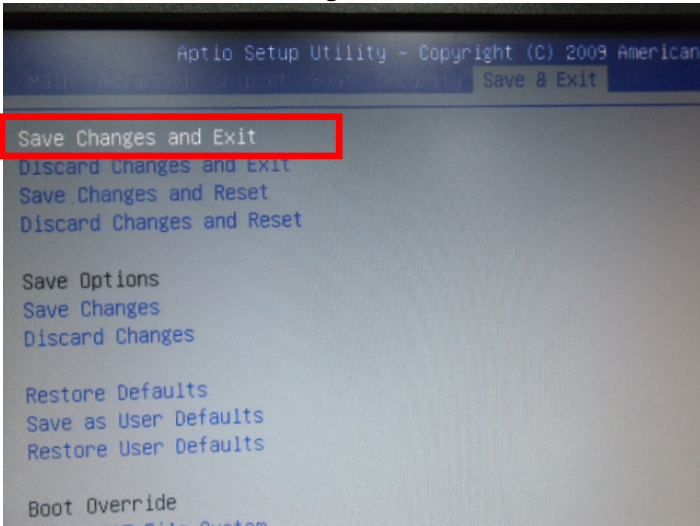

Step 7: Press **Ctrl-I** to enter **MAIN MENU**

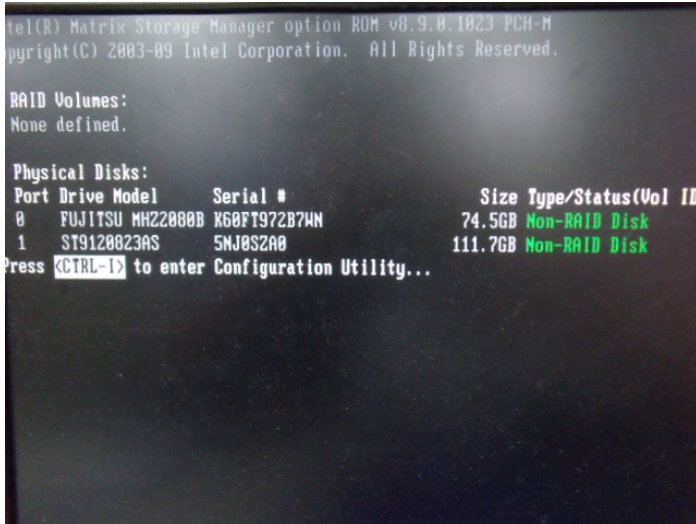

Step 8: Choose "1.Create RAID Volume"

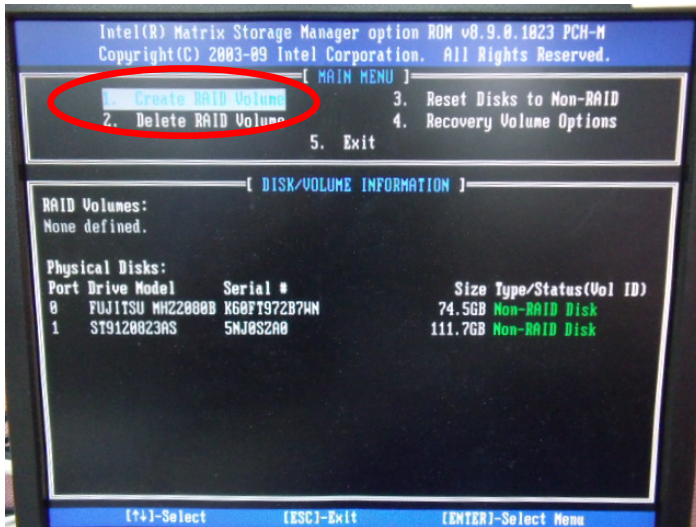

Step 9: RAID Level -> RAID0(Stripe)

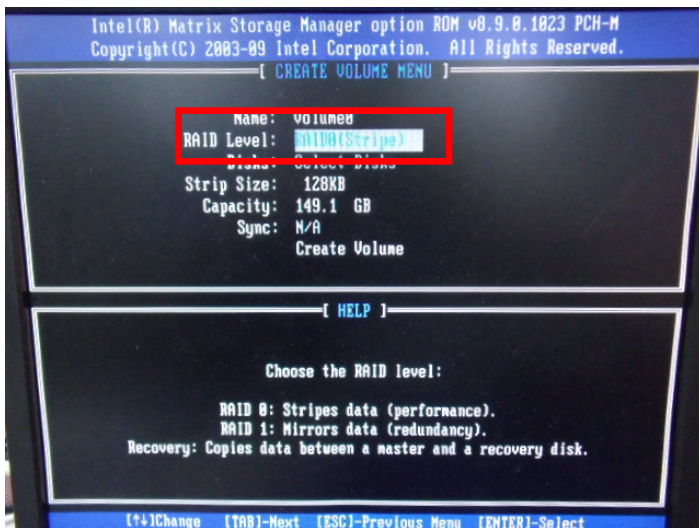

Step 10: Choose "Create Volume"

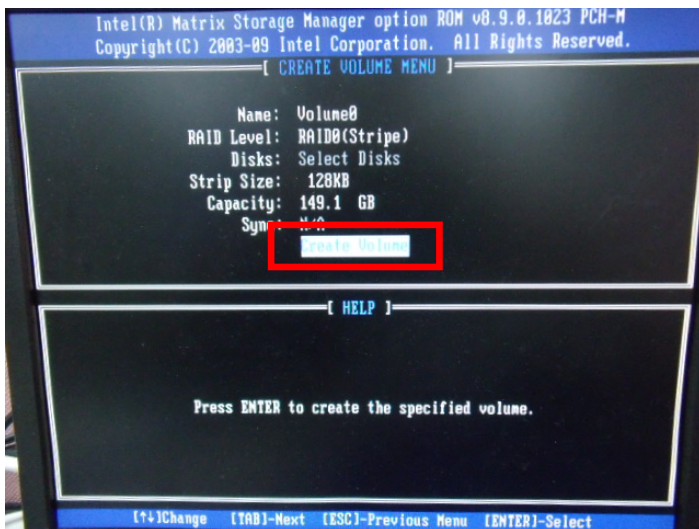

Step 11: Choose "Y"

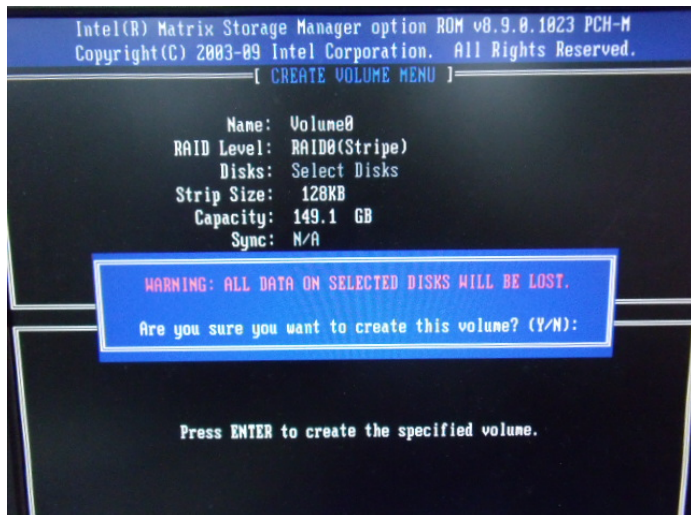

Step 12: Choose "5. Exit"

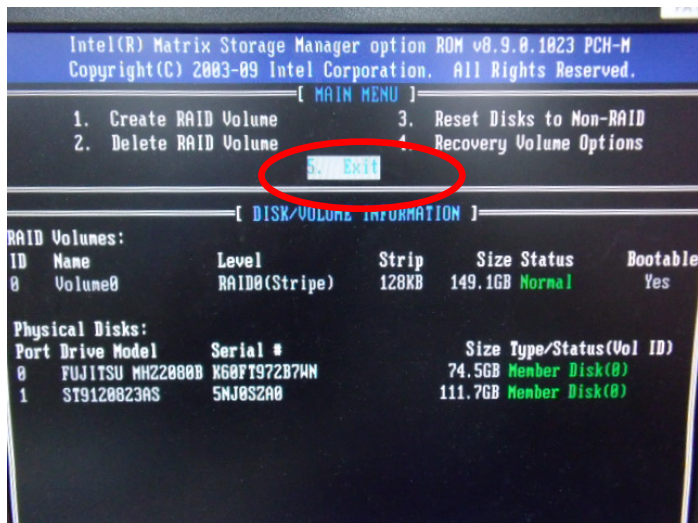

Step 13: Choose “Y”

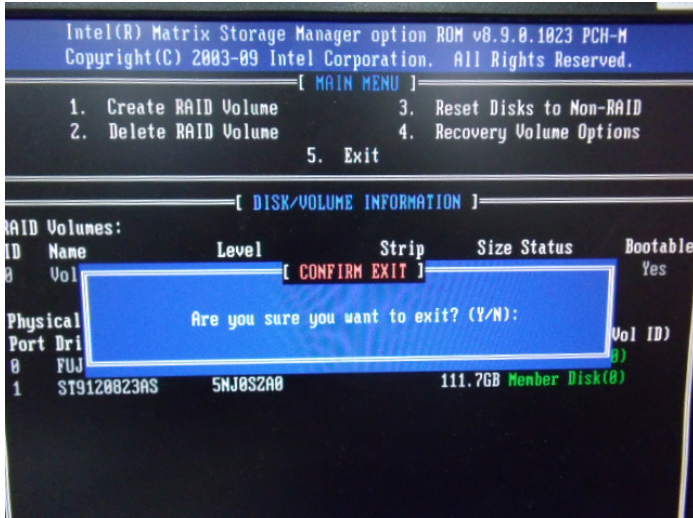

Step 14: Setup OS

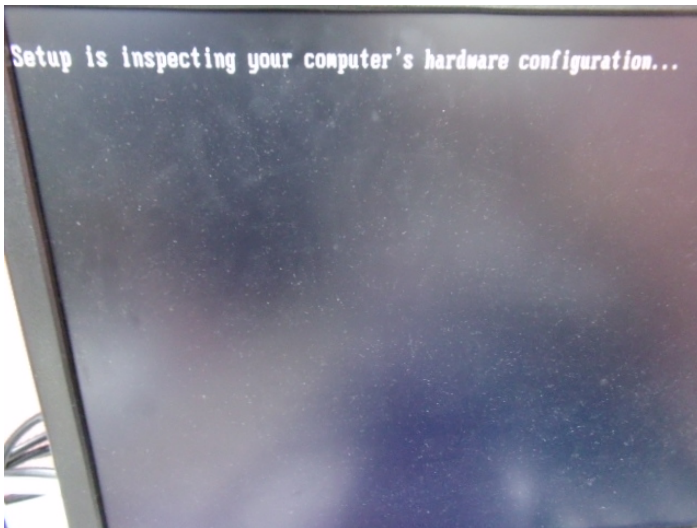

Step 15: Press "F6"



Step 16: Choose "S"

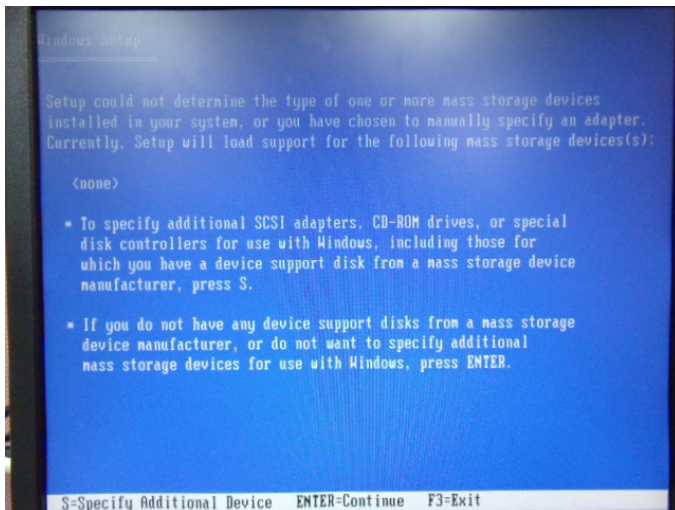

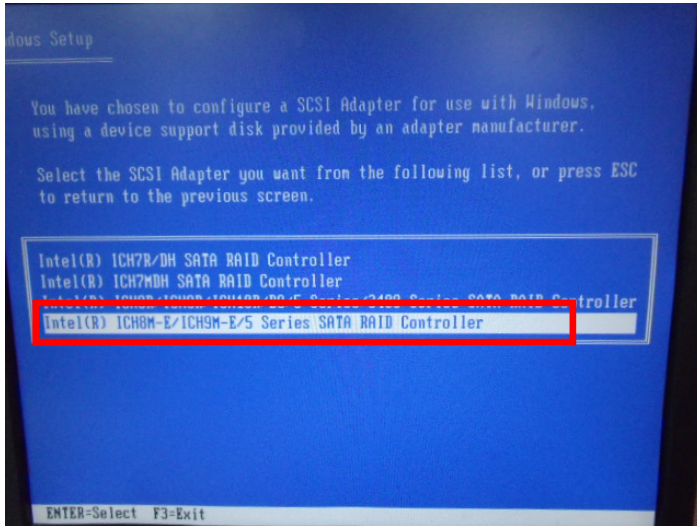
Step 17: Choose “Intel(R) ICH8M-E/ICH9M-E/5 Series SATA RAID Controller”**Step 18: It will show the model number you select and then press “ENTER”**

Step 19: Setup is starting Windows

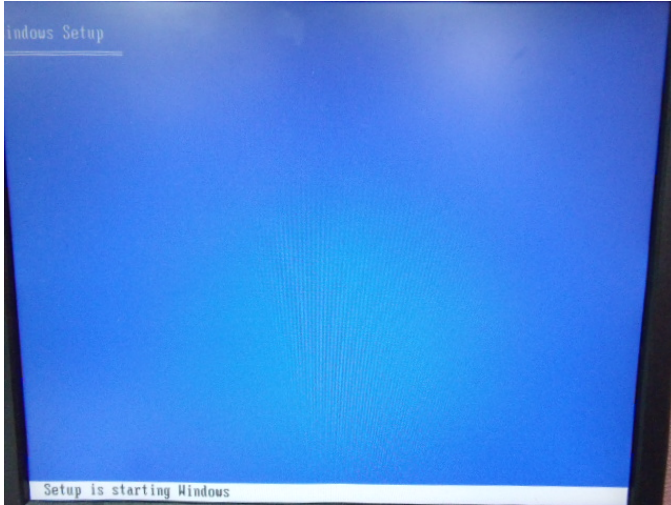

B.2 Setting AHCI

OS installation to setup AHCI Mode

Step 1: Copy the files below from “**Driver DVD -> Raid Driver -> F6 Floppy - x86**” to Disk

 F6Readme 文字文件 8 KB	 iaAHCI 安全性目錄 9 KB
 iaAHCI 安裝資訊 9 KB	 iaStor 安全性目錄 8 KB
 iaStor 安裝資訊 8 KB	 iaStor 系統檔案 423 KB
 license 文字文件 5 KB	 readme 文字文件 78 KB
 TXTSETUP.OEM OEM 檔案 6 KB	

Step 2: Connect the USB Floppy (disk with RAID files) to the board



Step 3: The setting procedures “In BIOS Setup Menu”

A: Advanced -> SATA Configuration -> SATA Configuration -> SATA Mode -> AHCI Mode

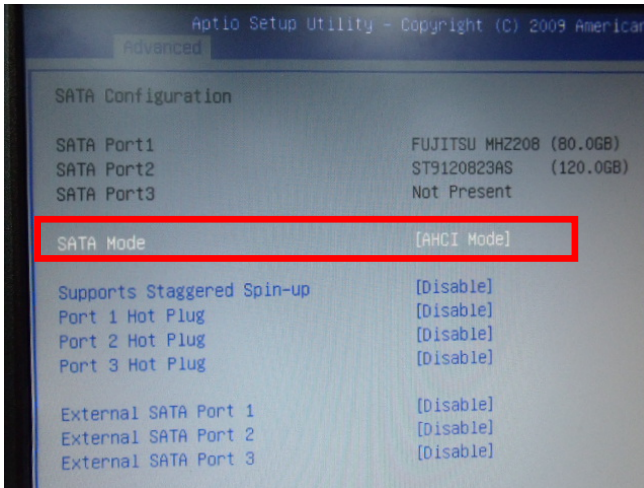

Step 4: The setting procedures “In BIOS Setup Menu”

B: Boot -> Boot Option #1 -> DVD-ROM Type

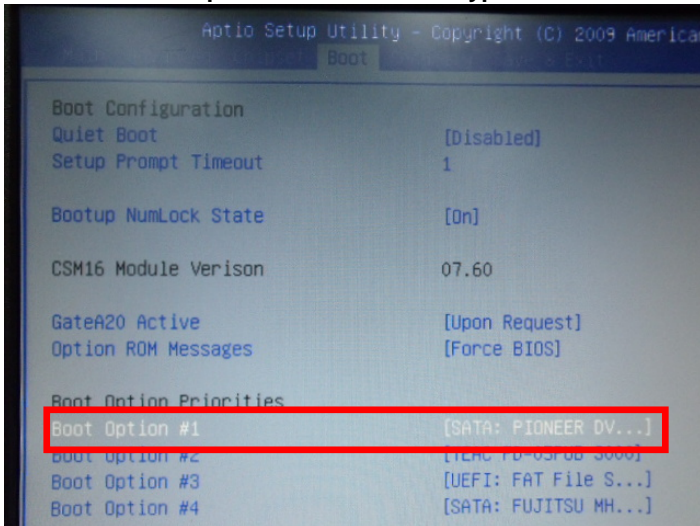

Step 5: The setting procedures "In BIOS Setup Menu"

C: Save & Exit -> Save Changes and Exit

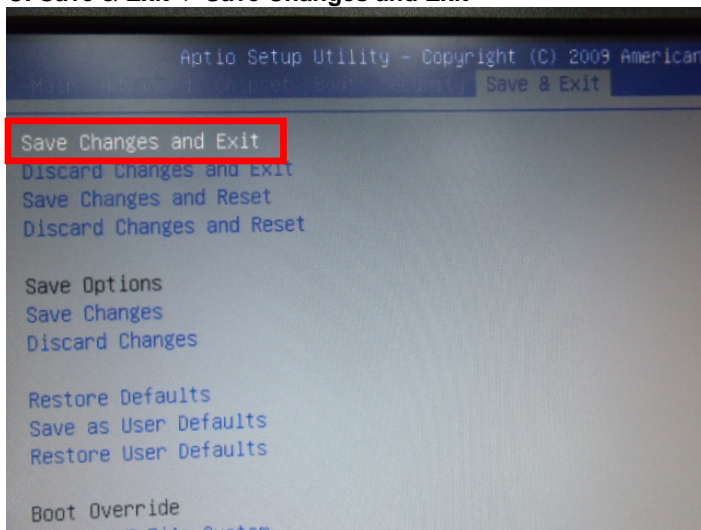

Step 6: Setup OS

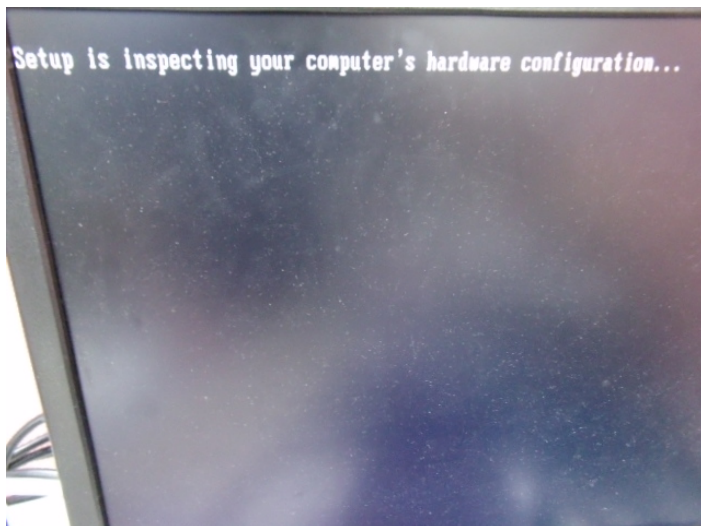

Step 7: Press "F6"



Step 8: Choose "S"



Step 9: Choose “Intel(R) 5 Series 6 Port SATA AHCI Controller”

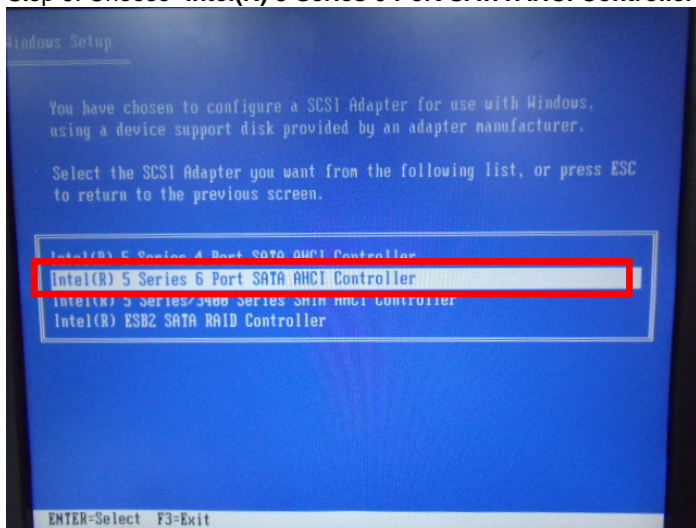

Step 10: It will show the model number you select and then press “ENTER”

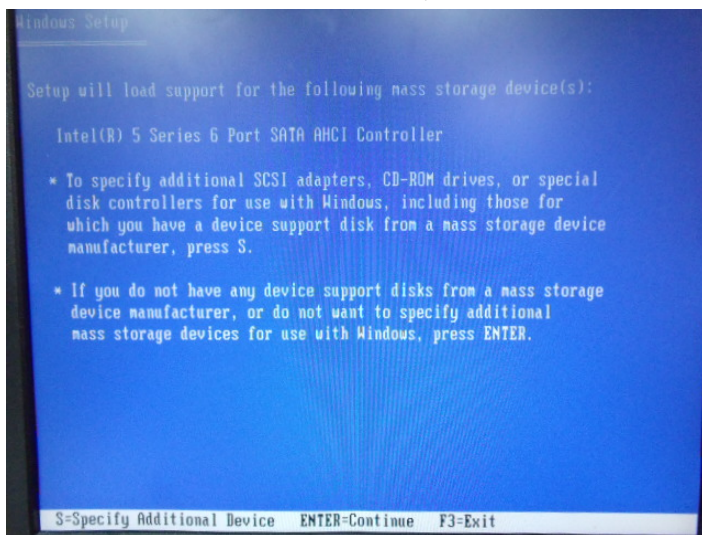

Step 11: Setup is loading files

