

AEC-6613

Fanless Embedded Box PC

User's Manual 5th Ed

Copyright Notice

This document is copyrighted, 2019. All rights are reserved. The original manufacturer reserves the right to make improvements to the products described in this manual at any time without notice.

No part of this manual may be reproduced, copied, translated, or transmitted in any form or by any means without the prior written permission of the original manufacturer. Information provided in this manual is intended to be accurate and reliable. However, the original manufacturer assumes no responsibility for its use, or for any infringements upon the rights of third parties that may result from its use.

The material in this document is for product information only and is subject to change without notice. While reasonable efforts have been made in the preparation of this document to assure its accuracy, AAEMON assumes no liabilities resulting from errors or omissions in this document, or from the use of the information contained herein.

AAEMON reserves the right to make changes in the product design without notice to its users.

Acknowledgement

All other products' name or trademarks are properties of their respective owners.

- Microsoft Windows is a registered trademark of Microsoft Corp.
- Intel, Pentium, Celeron, and Xeon are registered trademarks of Intel Corporation
- Core, Atom are trademarks of Intel Corporation
- ITE is a trademark of Integrated Technology Express, Inc.
- IBM, PC/AT, PS/2, and VGA are trademarks of International Business Machines Corporation.

All other product names or trademarks are properties of their respective owners.

Packing List

Before setting up your product, please make sure the following items have been shipped:

Item	Quantity
● AEC-6613	1
● 3 Pin DC-In Power Connector	1
● Screw package	1
● RAM Thermal Pad x 1 (60mm x 25mm x 3mm)	1
● Wallmount brackets	2
● Product DVD	1

If any of these items are missing or damaged, please contact your distributor or sales representative immediately.

About this Document

This User's Manual contains all the essential information, such as detailed descriptions and explanations on the product's hardware and software features (if any), its specifications, dimensions, jumper/connector settings/definitions, and driver installation instructions (if any), to facilitate users in setting up their product.

Users may refer to the AAEON.com for the latest version of this document.

Safety Precautions

Please read the following safety instructions carefully. It is advised that you keep this manual for future references

1. All cautions and warnings on the device should be noted.
2. All cables and adapters supplied by AAEON are certified and in accordance with the material safety laws and regulations of the country of sale. Do not use any cables or adapters not supplied by AAEON to prevent system malfunction or fires.
3. Make sure the power source matches the power rating of the device.
4. Position the power cord so that people cannot step on it. Do not place anything over the power cord.
5. Always completely disconnect the power before working on the system's hardware.
6. No connections should be made when the system is powered as a sudden rush of power may damage sensitive electronic components.
7. If the device is not to be used for a long time, disconnect it from the power supply to avoid damage by transient over-voltage.
8. Always disconnect this device from any AC supply before cleaning.
9. While cleaning, use a damp cloth instead of liquid or spray detergents.
10. Make sure the device is installed near a power outlet and is easily accessible.
11. Keep this device away from humidity.
12. Place the device on a solid surface during installation to prevent falls
13. Do not cover the openings on the device to ensure optimal heat dissipation.
14. Watch out for high temperatures when the system is running.
15. Do not touch the heat sink or heat spreader when the system is running
16. Never pour any liquid into the openings. This could cause fire or electric shock.

17. As most electronic components are sensitive to static electrical charge, be sure to ground yourself to prevent static charge when installing the internal components. Use a grounding wrist strap and contain all electronic components in any static-shielded containers.
18. If any of the following situations arises, please the contact our service personnel:
 - i. Damaged power cord or plug
 - ii. Liquid intrusion to the device
 - iii. Exposure to moisture
 - iv. Device is not working as expected or in a manner as described in this manual
 - v. The device is dropped or damaged
 - vi. Any obvious signs of damage displayed on the device
19. **DO NOT LEAVE THIS DEVICE IN AN UNCONTROLLED ENVIRONMENT WITH TEMPERATURES BEYOND THE DEVICE'S PERMITTED STORAGE TEMPERATURES (SEE CHAPTER 1) TO PREVENT DAMAGE.**

FCC Statement

Warning!



This device complies with Part 15 FCC Rules. Operation is subject to the following two conditions: (1) this device may not cause harmful interference, and (2) this device must accept any interference received including interference that may cause undesired operation.

Caution:

There is a danger of explosion if the battery is incorrectly replaced. Replace only with the same or equivalent type recommended by the manufacturer. Dispose of used batteries according to the manufacturer's instructions and your local government's recycling or disposal directives.

Attention:

Il y a un risque d'explosion si la batterie est remplacée de façon incorrecte. Ne la remplacer qu'avec le même modèle ou équivalent recommandé par le constructeur. Recycler les batteries usées en accord avec les instructions du fabricant et les directives gouvernementales de recyclage.

China RoHS Requirements (CN)

产品中有毒有害物质或元素名称及含量

AAEON Embedded Box PC/ Industrial System

部件名称	有毒有害物质或元素					
	铅 (Pb)	汞 (Hg)	镉 (Cd)	六价铬 (Cr(VI))	多溴联苯 (PBB)	多溴二苯醚 (PBDE)
印刷电路板 及其电子组件	○	○	○	○	○	○
外部信号 连接器及线材	○	○	○	○	○	○
外壳	○	○	○	○	○	○
中央处理器 与内存	○	○	○	○	○	○
硬盘	○	○	○	○	○	○
电源	○	○	○	○	○	○
<p>○: 表示该有毒有害物质在该部件所有均质材料中的含量均在 SJ/T 11363-2006 标准规定的限量要求以下。</p> <p>X: 表示该有毒有害物质至少在该部件的某一均质材料中的含量超出 SJ/T 11363-2006 标准规定的限量要求。</p> <p>备注: 一、此产品所标示之环保使用期限, 系指在一般正常使用状况下。 二、上述部件物质中央处理器、内存、硬盘、电源为选购品。</p>						

China RoHS Requirement (EN)

Poisonous or Hazardous Substances or Elements in Products
 AAEON Embedded Box PC/ Industrial System

Component	Poisonous or Hazardous Substances or Elements					
	Lead (Pb)	Mercury (Hg)	Cadmium (Cd)	Hexavalent Chromium (Cr(VI))	Polybrominated Biphenyls (PBB)	Polybrominated Diphenyl Ethers (PBDE)
PCB & Other Components	○	○	○	○	○	○
Wires & Connectors for External Connections	○	○	○	○	○	○
Chassis	○	○	○	○	○	○
CPU & RAM	○	○	○	○	○	○
Hard Disk	○	○	○	○	○	○
PSU	○	○	○	○	○	○
<p>O: The quantity of poisonous or hazardous substances or elements found in each of the component's parts is below the SJ/T 11363-2006-stipulated requirement.</p> <p>X: The quantity of poisonous or hazardous substances or elements found in at least one of the component's parts is beyond the SJ/T 11363-2006-stipulated requirement.</p> <p>Note: The Environment Friendly Use Period as labeled on this product is applicable under normal usage only</p>						

Table of Contents

- Chapter 1 - Product Specifications1**
 - 1.1 Specifications 2
- Chapter 2 – Hardware Information 4**
 - 2.1 Dimensions 5
 - 2.2 Jumpers and Connectors 11
 - 2.3 List of Jumpers 13
 - 2.4 List of Connectors 14
 - 2.4.1 COM2 Port #4 (CN16) 16
 - 2.4.2 COM2 Port #3 (CN18) 16
 - 2.4.3 COM2 Port #2 (CN20) 16
 - 2.4.4 RCOM Port #1 (CN33) 17
 - 2.5 CFast™ Card Installation 18
 - 2.6 Hard Disk Drive Installation (Model A1M/A2M) 19
 - 2.7 SDRAM Installation 22
 - 2.8 DIN Rail Installation 26
 - 2.9 Wallmount Kit Installation 27
- Chapter 3 - AMI BIOS Setup 28**
 - 3.1 System Test and Initialization 29
 - 3.2 AMI BIOS Setup 30
 - 3.3 Setup Submenu: Main 31
 - 3.4 Setup Submenu: Advanced 32
 - 3.4.1 Advanced: ACPI Settings 34
 - 3.4.2 Advanced: CPU Computing 35
 - 3.4.3 Advanced: SATA Configuration 36
 - 3.4.4 Advanced: USB Configuration 37
 - 3.4.5 Advanced: Super IO Configuration 39

3.4.5.1	Super IO Configuration: Serial Port 2 Configuration	40
3.4.6	Advanced: Smart Fan Function	42
3.4.7	Advanced: H/W Monitor	43
3.5	Setup submenu: Chipset	44
3.5.1	Chipset: Host Bridge	45
3.5.1.1	Chipset: IGD Configuration	46
3.5.2	Chipset: South Bridge	47
3.5.2.1	South Bridge: TPT Devices	48
3.6	Setup submenu: Boot	49
3.6.1	Boot: BBS Priorities	50
3.7	Security	51
3.7.1	Security: HDD Security	53
3.8	Setup submenu: Save & Exit	55
Chapter 4	– Drivers Installation	56
4.1	Product CD/DVD	57
Appendix A	- Watchdog Timer Programming	59
A.1	Watchdog Timer Programming	60
A.2	ITE8783 Watchdog Timer Initial Program	64
Appendix B	- I/O Information	69
B.1	I/O Address Map	70
B.2	1 st Memory Address Map	72
B.3	IRQ Mapping Chart	73
B.4	DMA Channel Assignments	75
Appendix C	–AHCI Settings	76
C.1	Setting AHCI	77

Chapter 1

Product Specifications

1.1 Specifications

System

CPU	Intel® Atom™ D2550, 1.86 GHz
Chipset	Intel® NM10
System Memory	DDR3 800/1066 SODIMM slot x 1, up to 4 GB
Display Interface	VGA, DVI-D (A3/A4/A3M/A4M)
Storage Device	CFast™, HDD/SSD
Ethernet	Realtek RTL 8111E, 10/100/1000Base-TX x 2 RS-232/422/485 x 1
I/O	RS-232 x 3 USB 2.0 x 4 VGA x 1 DVI-D x1 (A3 / A4 / A3M / A4M) Line-out x 1 LAN x 2 CFast slot x 2 Antenna holes x 2 Power switch Power input
Expansion	Full-size Mini-Card x 1 (PCI-E + USB, w/ SIM slot)
Indicator	Power LED HDD active LED
OS support	Windows® 7(32-bit), WES2009, WES7 32-bit, Linux Fedora 15/ Kernel 2.6.38.6

Power

Power Requirement	9 - 30V with 3-pin terminal block 12V with lockable DC jack
-------------------	--

Mechanical

Mounting	Wallmount DIN Rail (Mounting kit is optional)
Dimensions (W x H x D)	8.35" x 3.1" x 2.25" (212.15mm x 78.88mm x 107mm)
Gross Weight	8.38 lb (3.8 kg)
Net Weight	4.57 lb (2.07 kg)

Environmental

Operating Temperature	-4°F ~ 131°F (-20°C ~ 55°C) with wide temperature CFast™ card -4°F ~ 140°F (-20°C ~ 60°C) with wide temperature HDD (according to IEC68-2-14 with 0.5 m/s AirFlow; with industrial devices)
Storage Temperature	-4°F ~ 158°F (-20°C ~ 70°C)
Storage Humidity	95% @ 40°C, non-condensing
Anti-Vibration	5 Grms/ 5 ~ 500Hz/ operation –CFast™ card 1 5 Grms/ 5 ~ 500Hz/ operation – HDD
Certification	CE/FCC class A

Chapter 2

Hardware Information

2.1 Dimensions

Model A1

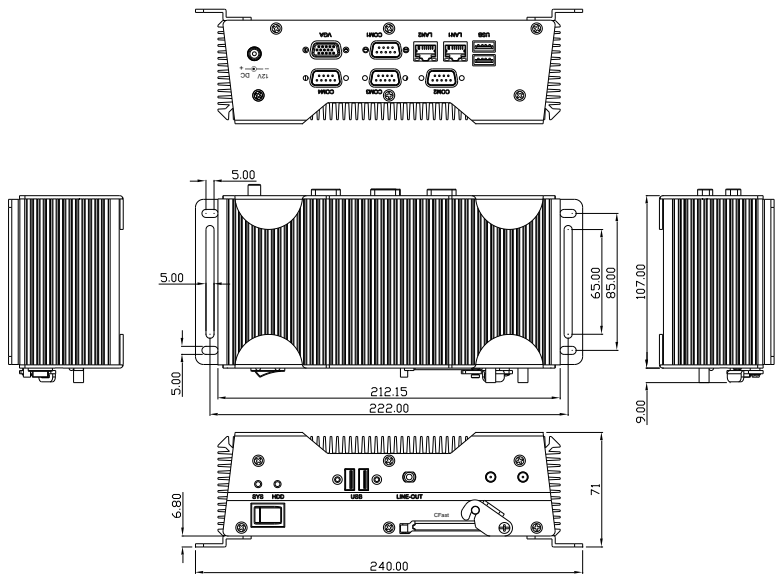

Model A1M

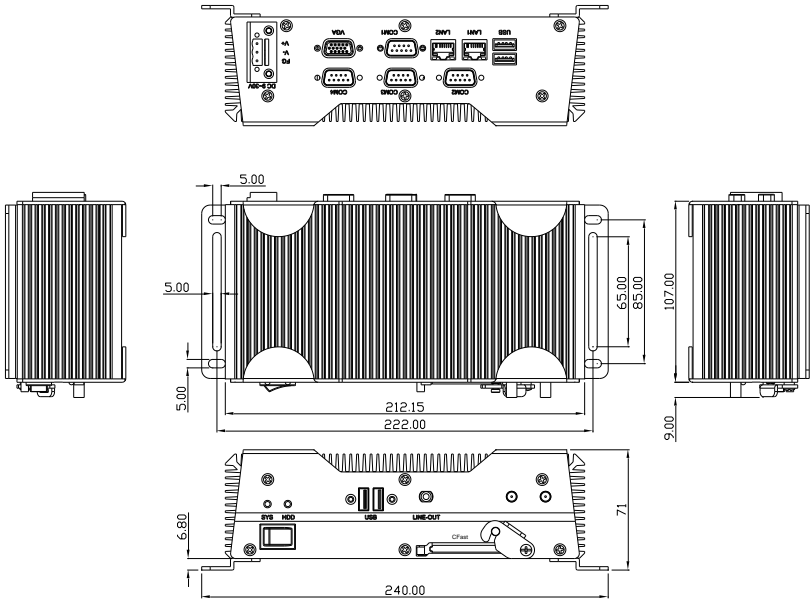

Model A2

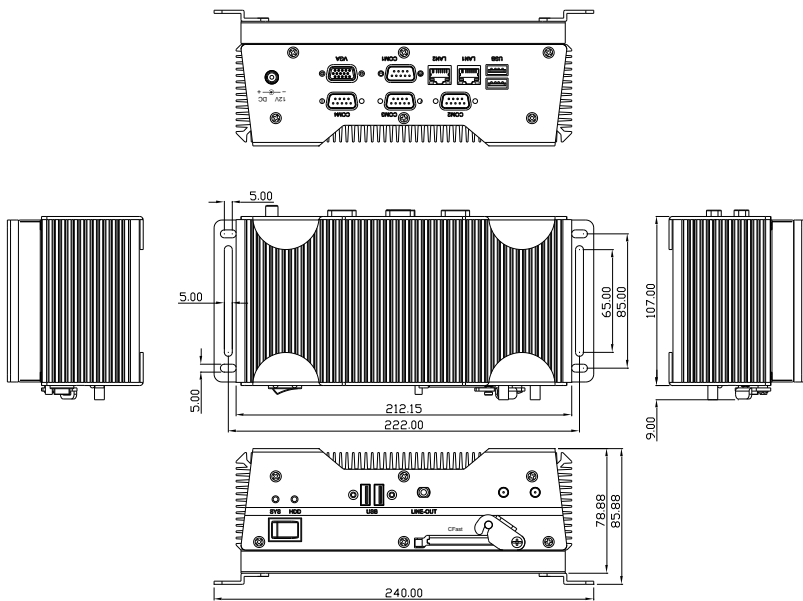

Model A2M

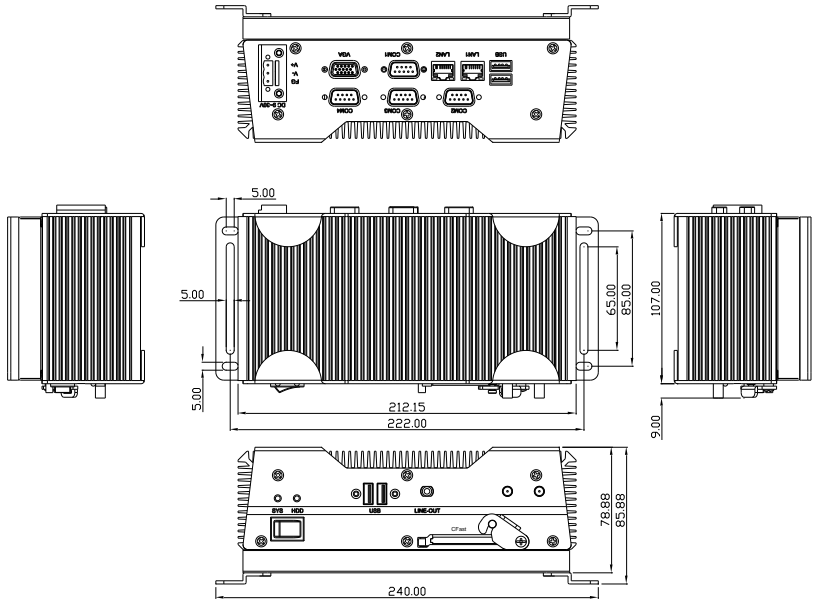

Model A3/A4

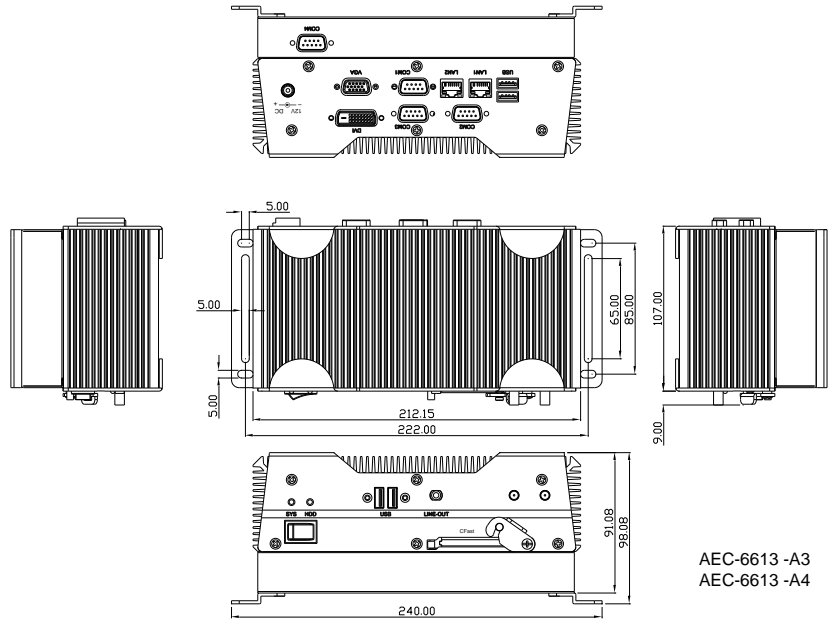

AEC-6613 -A3
AEC-6613 -A4

Model A3M/A4M

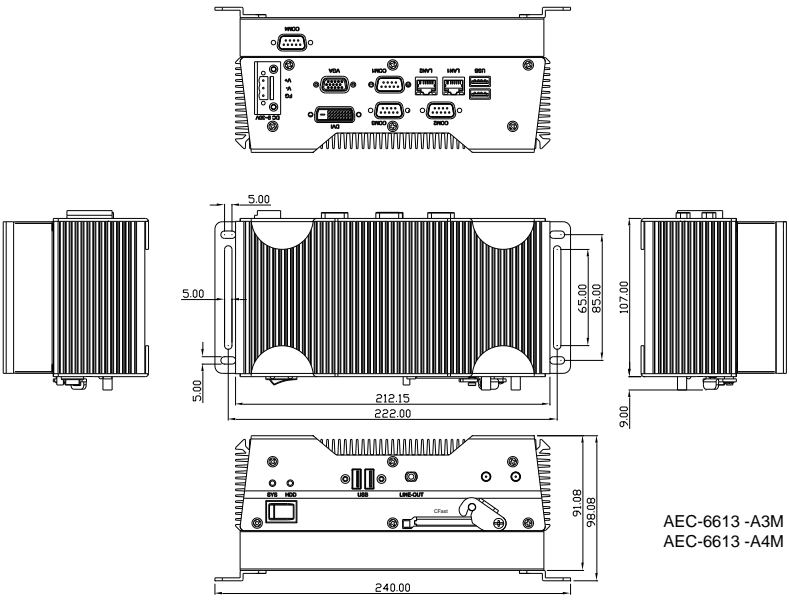

2.2 Jumpers and Connectors

Component Side

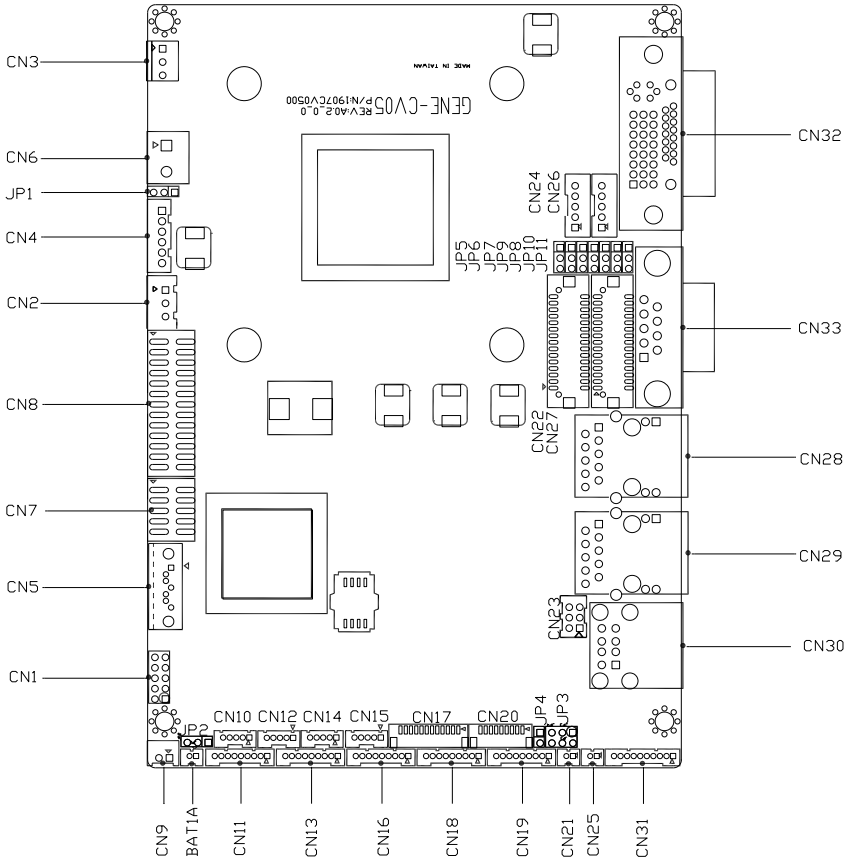

Solder Side

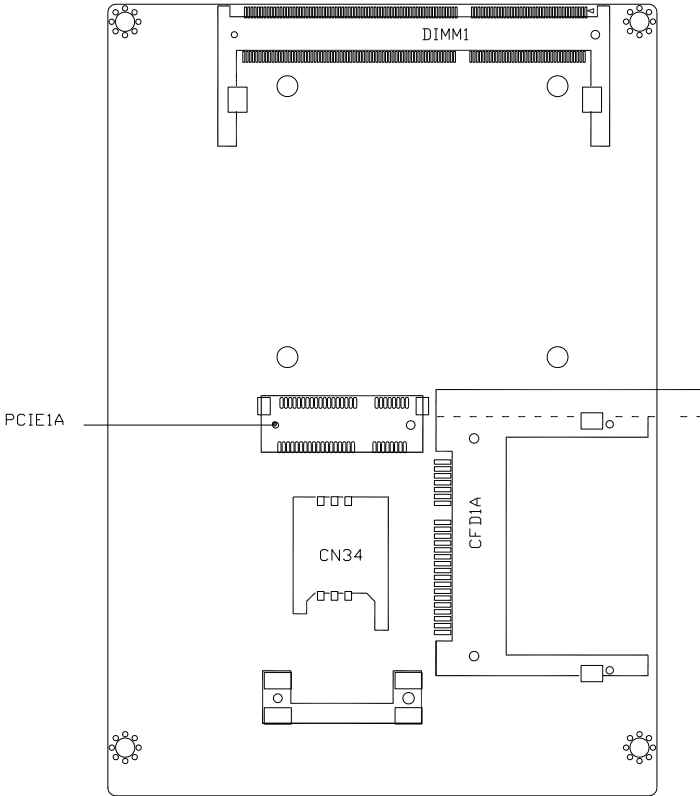

2.3 List of Jumpers

Please refer to the table below for all of the system's connectors that you can configure for your application

Label	Function
JP1	Auto Power Button Selection
JP2	Clear CMOS
JP3	COM2 RI/+5/+12V Selection
JP4	Touch Screen 4/5/8-wires Mode Selection
JP5	Brightness Control for 2nd LVDS
JP6	2nd LVDS Backlight Bias/PWM Mode Selection
JP7	2nd LVDS Operating Voltage Selection
JP8	2nd LVDS Inverter Voltage Selection
JP9	1st LVDS Inverter Voltage Selection
JP10	1st LVDS Backlight Bias/PWM Mode Selection
JP11	1st LVDS Operating Voltage Selection

2.4 List of Connectors

Please refer to the table below for all of the system's connectors that you can configure for your application

Label	Function
CN1	Front Panel
CN2	External +5VSB Input
CN3	CPU FAN
CN4	+5VSB Output w/ SMBus
CN5	SATA Port
CN6	External 12V Input
CN7	Digital I/O
CN8	Parallel Port
CN9	+5V Output for SATA HDD usage
CN10	USB Port #6
CN11	COM Port #6
CN12	USB Port #5
CN13	COM Port #5
CN14	USB Port #4
CN15	USB Port #3
CN16	COM Port #4
CN17	LPC Expansion I/F
CN18	COM Port #3
CN19	Touch Screen
CN20	COM Port #2
CN21	Stereo-R Channel
CN22	2nd LVDS (Dual channel 18/24bit)
CN23	PS/2 Keyboard & Mouse

CN24	2nd LVDS Inverter
CN25	Stereo-L Channel
CN26	1st LVDS Inverter
CN27	1st LVDS (Single channel 18/24bit)
CN28	2nd RJ-45 Ethernet
CN29	1st RJ-45 Ethernet
CN30	USB Port #1 and #2
CN31	Audio Line In/Out and MIC
CN32	CRT/DVI (Configured by manufacturing)
CN33	COM Port #1
CN34	SIM Card Socket
CFD1	CFAST™
PCIE1	MiniCard/mSATA (Configured by manufacturing)
DIMM1	DDR3 SODIMM Slot

2.4.1 COM2 Port #4 (CN16)

Pin	Signal	Pin	Signal
1	DCDD	2	RXD
3	TXD	4	DTRD
5	Ground	6	DSRD
7	RTSD	8	CTSD
9	RID		

2.4.2 COM2 Port #3 (CN18)

Pin	Signal	Pin	Signal
1	DCDC	2	RXC
3	TXC	4	DTRC
5	Ground	6	DSRC
7	RTSC	8	CTSC
9	RIC		

2.4.3 COM2 Port #2 (CN20)

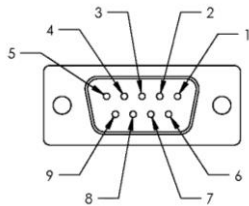

RS-232

Pin	Signal	Pin	Signal
1	DCDB	2	RXB
3	TXB	4	DTRB

5	Ground	6	DSRB
7	RTSB	8	CTSB
9	RIB/+5V/(+12V)		

RS-422

Pin	Signal	Pin	Signal
1	TXD-	2	RXD+
3	TXD+	4	RXD-
5	Ground	6	N/C
7	N/C	8	N/C
9	N/C / +5V / (+12V)		

RS-485

Pin	Signal	Pin	Signal
1	TXD-	2	N/C
3	TXD+	4	N/C
5	Ground	6	N/C
7	N/C	8	N/C
9	N/C / +5V / (+12V)		

2.4.4 RCOM Port #1 (CN33)

Pin	Signal	Pin	Signal
1	DCDA	2	RXA
3	TXA	4	DTRA
5	Ground	6	DSRA
7	RTSA	8	CTSA
9	RIA		

2.5 CFast™ Card Installation

Step 1: Install the CFast™ card.



Step 2: Lower the arm to secure.



2.6 Hard Disk Drive Installation (Model A1M/A2M)

Step 1: Open the base of AEC-6613 by removing the screws.



Step 2: Get the Hard Disk Drive ready.



Step 3: Place the HDD on the bracket and secure with screws

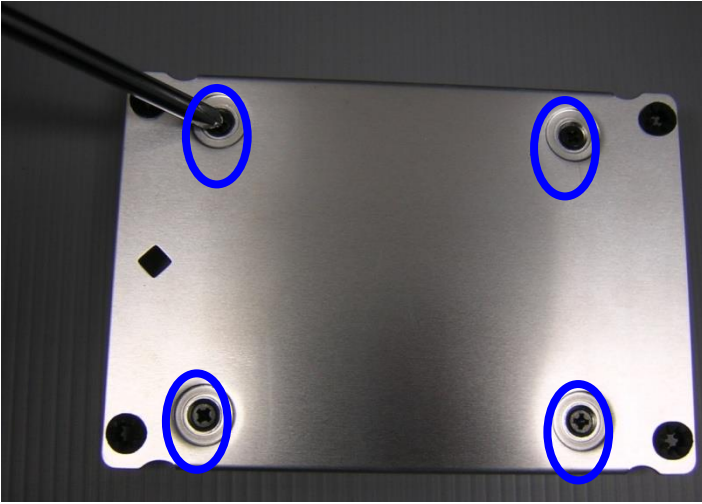

Step 4: Connect the SATA and power cables to the HDD.

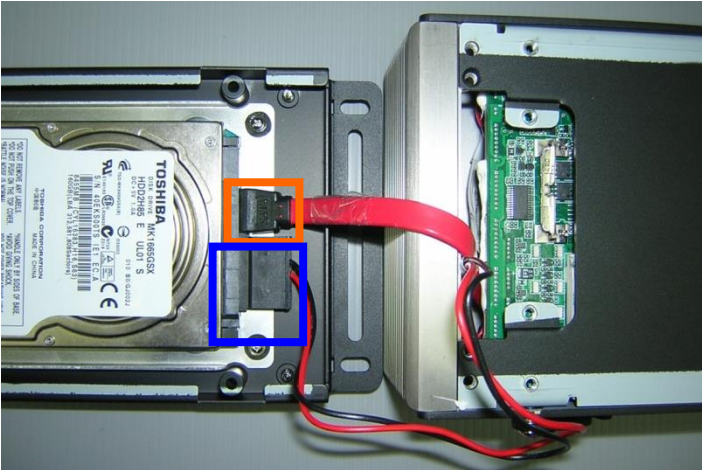

Step 5: Place the assembled HDD back into the device and secure with screws.



2.7 SDRAM Installation

Step 1: Remove the stands and base to access the interior

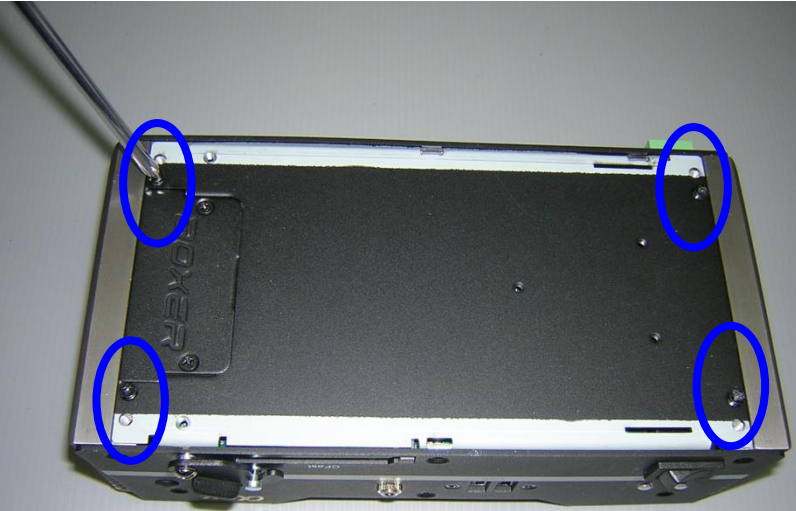
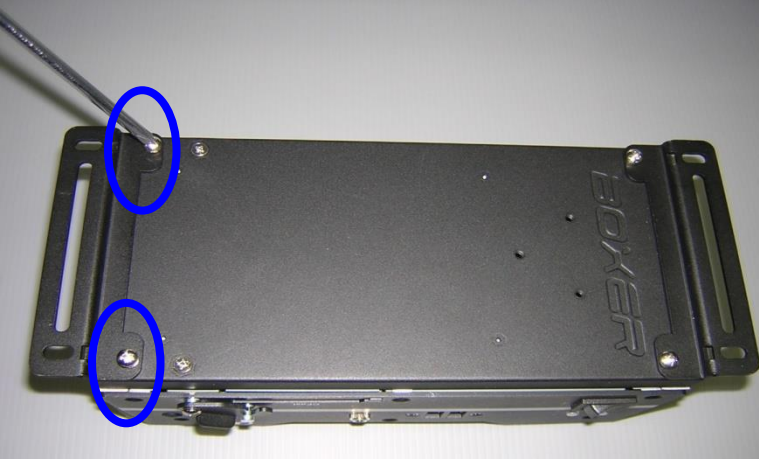

Step 2: Remove the highlighted screws to remove the front panel

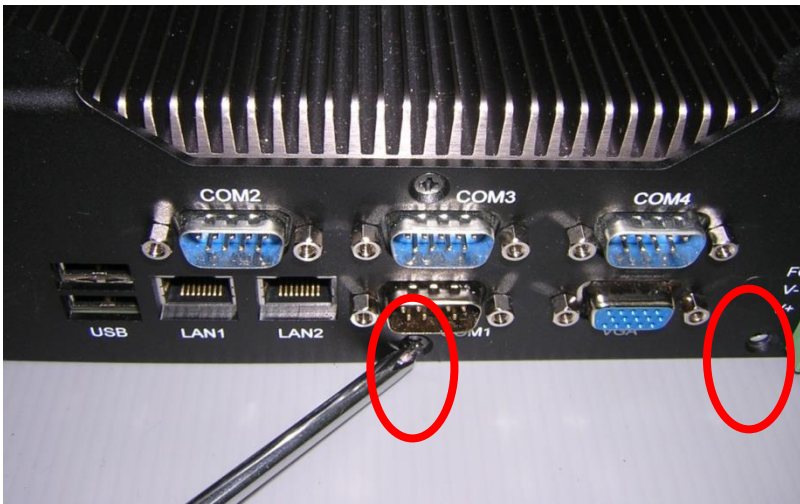

Step 3: Insert the SDRAM to the memory slot, push down to secure

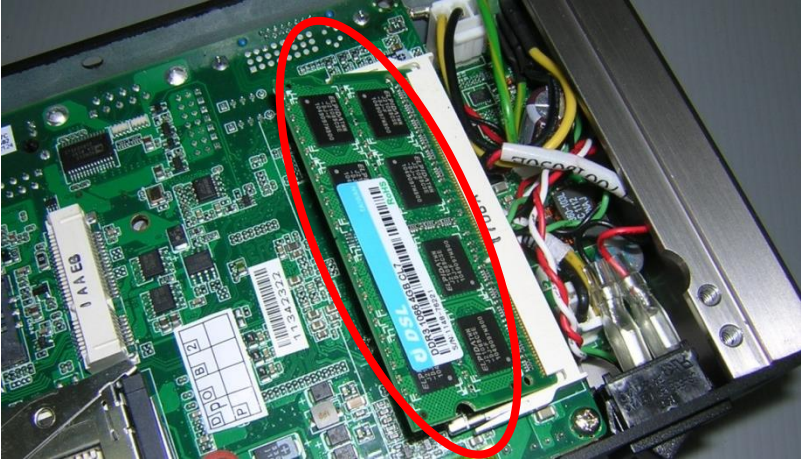

Step 4: Place a heat-spreading sheet onto the SDRAM.

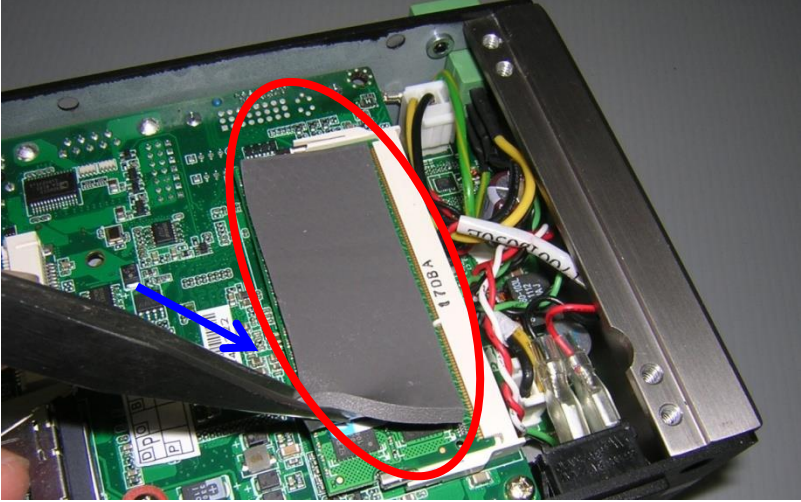

2.8 DIN Rail Installation

Step 1: Attach the DIN Rail kit onto the chassis as shown below.

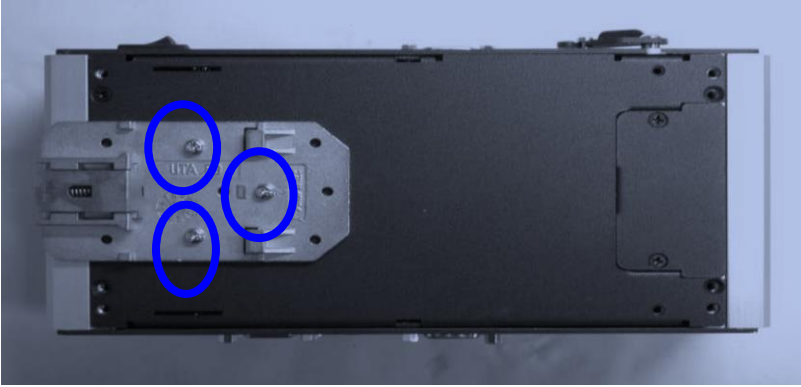

Step 2: Slide a DIN Rail into the DIN Rail kit to check installation

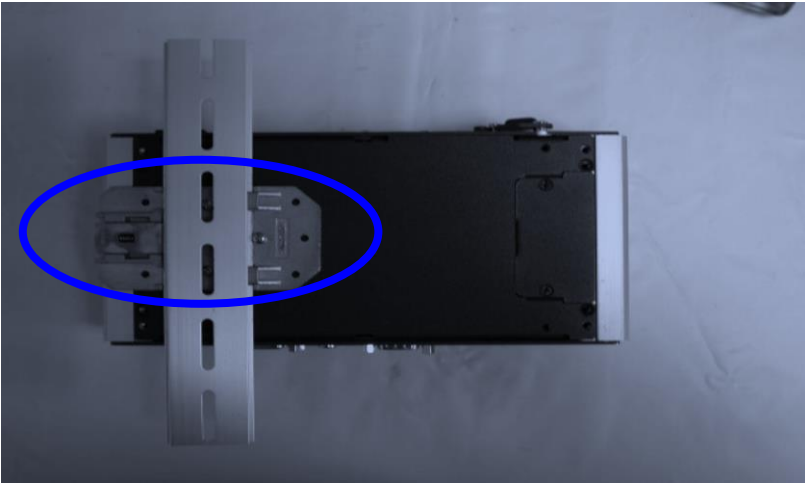

2.9 Wallmount Kit Installation

To attach the wallmount kit on to the AEC-6613, tightens the screws as shown in the diagram below.

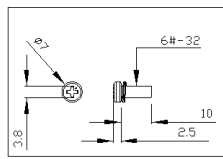
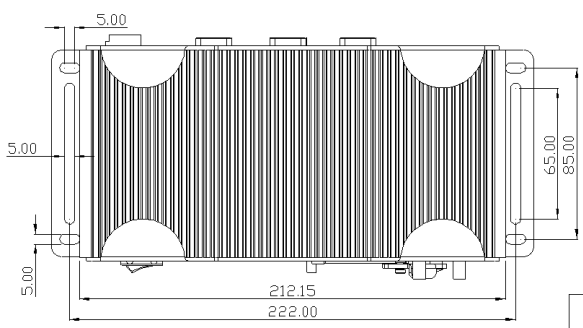
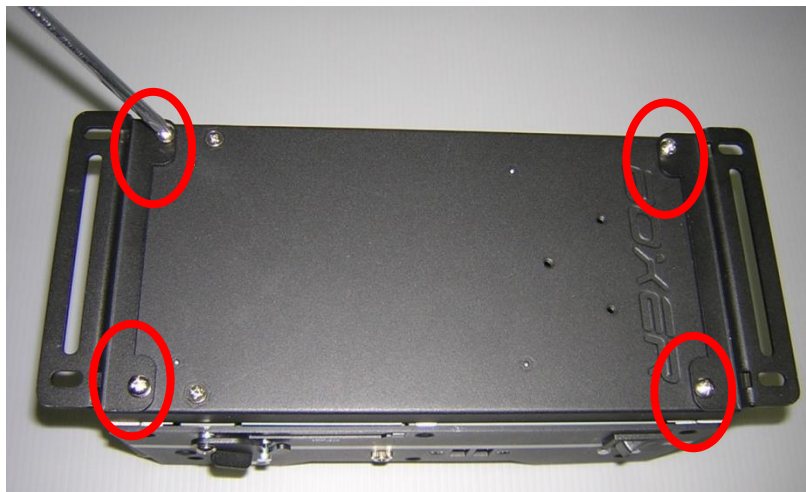

We suggest using this screw.

Chapter 3

AMI BIOS Setup

3.1 System Test and Initialization

The system uses certain routines to perform testing and initialization. If an error, fatal or non-fatal, is encountered, a few short beeps or an error message will be outputted. The board can usually continue the boot up sequence with non-fatal errors.

The system configuration verification routines check the current system configuration against the values stored in the CMOS memory. If they do not match, an error message will be outputted, in which case you will need to run the BIOS setup program to set the configuration information in memory.

There are three situations in which you will need to change the CMOS settings:

- You are starting your system for the first time
- You have changed your system's hardware
- The CMOS memory has lost power and the configuration information is erased

The system's CMOS memory uses a backup battery for data retention, which is to be replaced once emptied.

3.2 AMI BIOS Setup

The AMI BIOS ROM has a pre-installed Setup program that allows users to modify basic system configurations, which is stored in the battery-backed CMOS RAM and BIOS NVRAM so that the information is retained when the power is turned off.

To enter BIOS Setup, press or <F2> immediately while your computer is powering up.

The function for each interface can be found below.

Main – Date and time can be set here. Press <Tab> to switch between date elements

Advanced – Enable/ Disable boot option for legacy network devices

Chipset – For hosting bridge parameters

Boot – Enable/ Disable quiet Boot Option

Security – The setup administrator password can be set here

Save & Exit – Save your changes and exit the program

3.3 Setup Submenu: Main

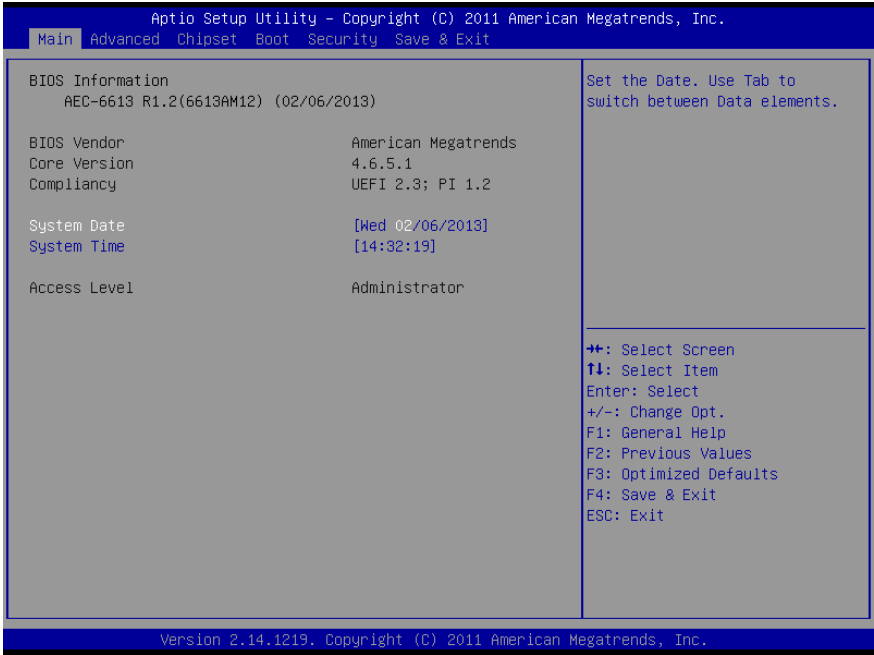

Options summary: **(default setting)**

System Date	Day MM:DD:YYYY	
Change the month, year and century. The 'Day' is changed automatically.		
System Time	HH : MM : SS	
Change the clock of the system.		

3.4 Setup Submenu: Advanced

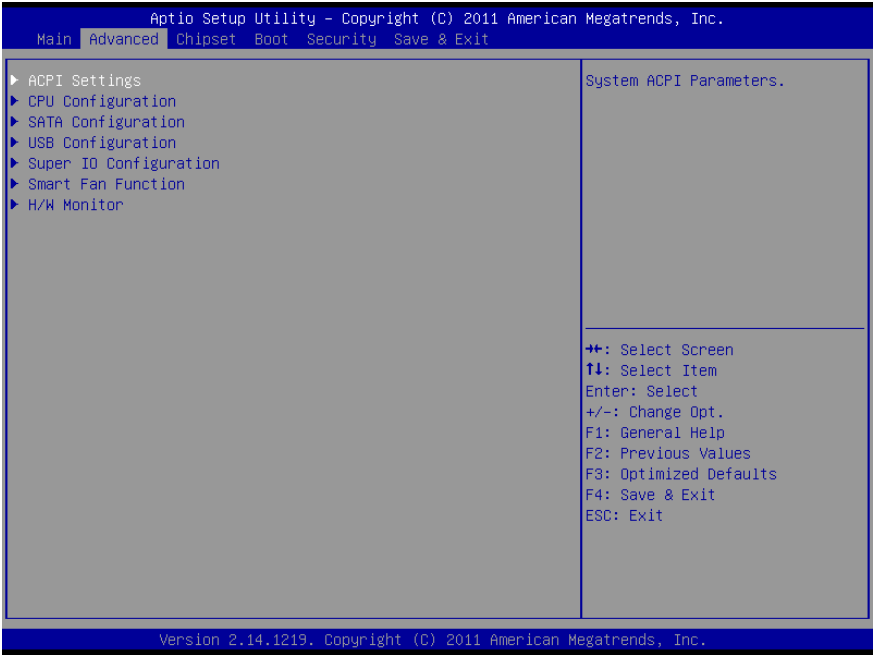

Options summary: **(default setting)**

ACPI Settings		
System ACPI Parameters		
CPU Configuration		
CPU Configuration Parameters		
SATA Configuration		
SATA Device Options Settings		
USB Configuration		
USB Configuration Parameters		
Super IO Configuration		
IT8783 Super IO Configuration Parameters		

Smart Fan Function		
Smart Fan Function settings		
H/W Monitor		
Monitor hardware status		

3.4.1 Advanced: ACPI Settings

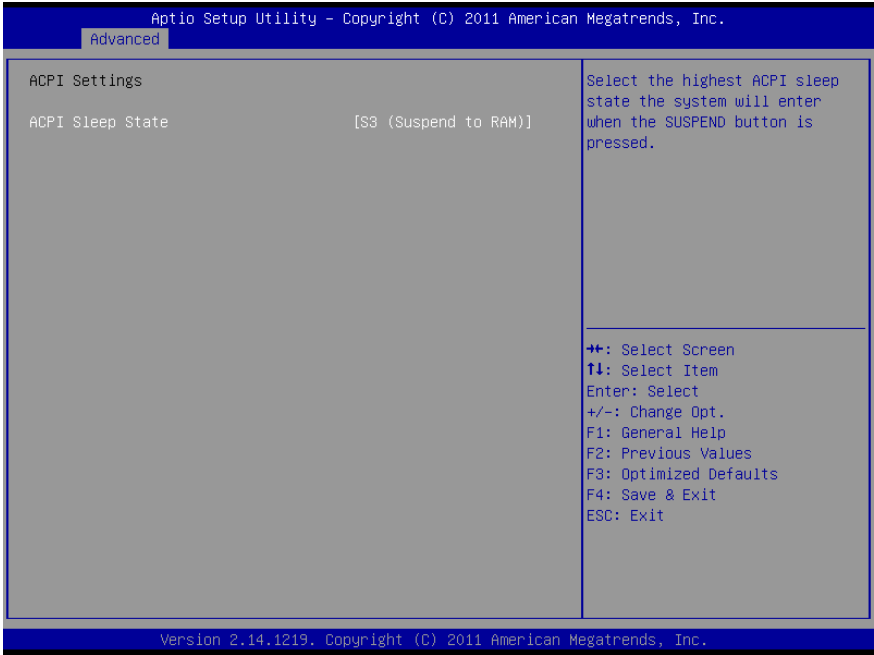

Options summary: **(default setting)**

ACPI Sleep State	Suspend Disabled	
	S3 (Suspend to RAM)	
Select the ACPI state used for System Suspend		

3.4.2 Advanced: CPU Computing

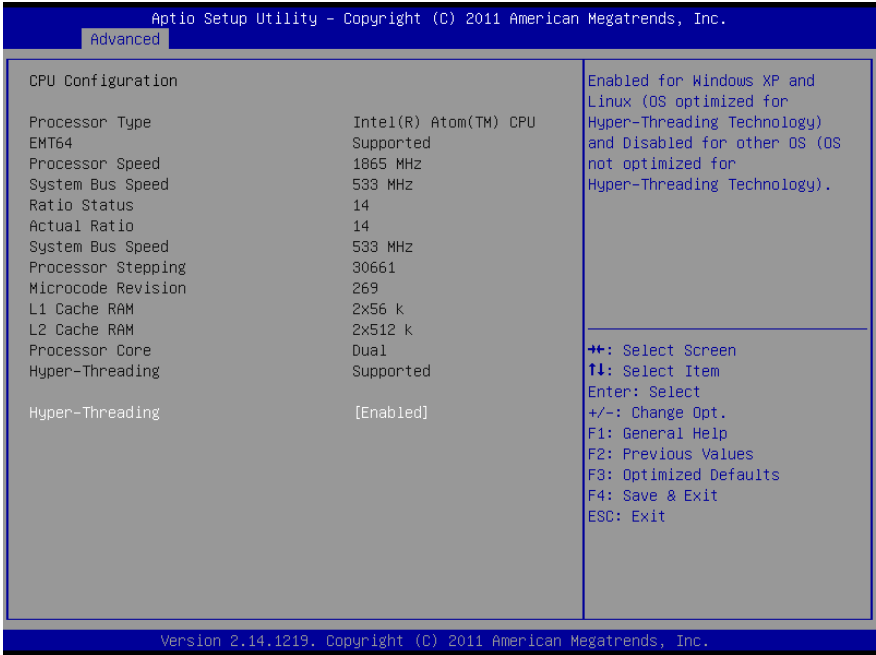

Options summary: (default setting)

Hyper-Threading	Disabled	
	Enabled	
CPU Hyper-Threading Technology support or not		

3.4.3 Advanced: SATA Configuration

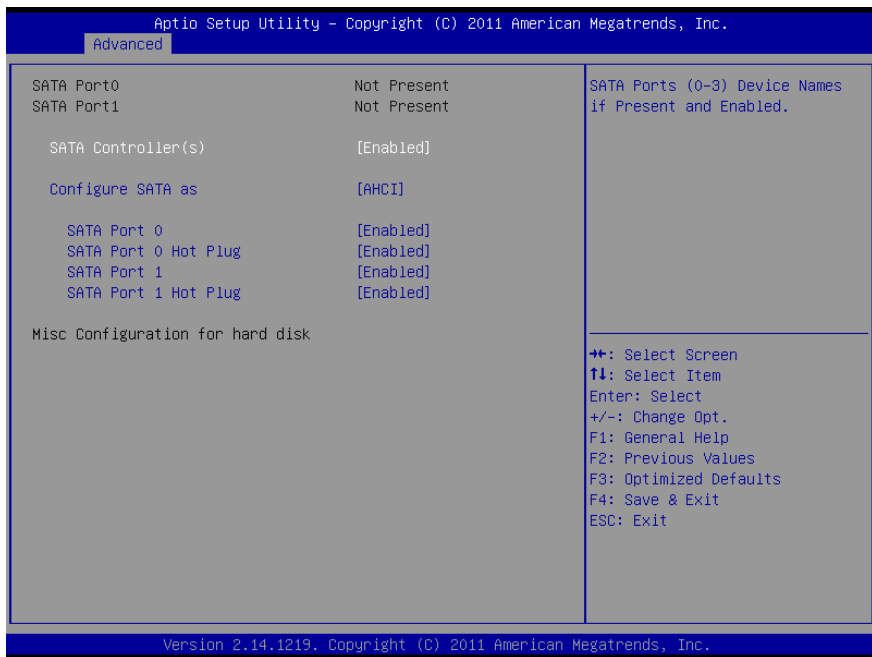

Options summary: **(default setting)**

SATA Controller(s)	Enabled	
	Disabled	
SATA Controller Enable/Disable		
SATA Mode	IDE	
	AHCI	
Configure SATA controller operating as IDE/AHCI mode.		
SATA PORTx	Enabled	
	Disabled	
Enable / Disable SATA Portx		
SATA Portx Hot Plug	Enabled	

	Disabled	
Enable / Disable SATA Portx Hot Plug function		

3.4.4 Advanced: USB Configuration

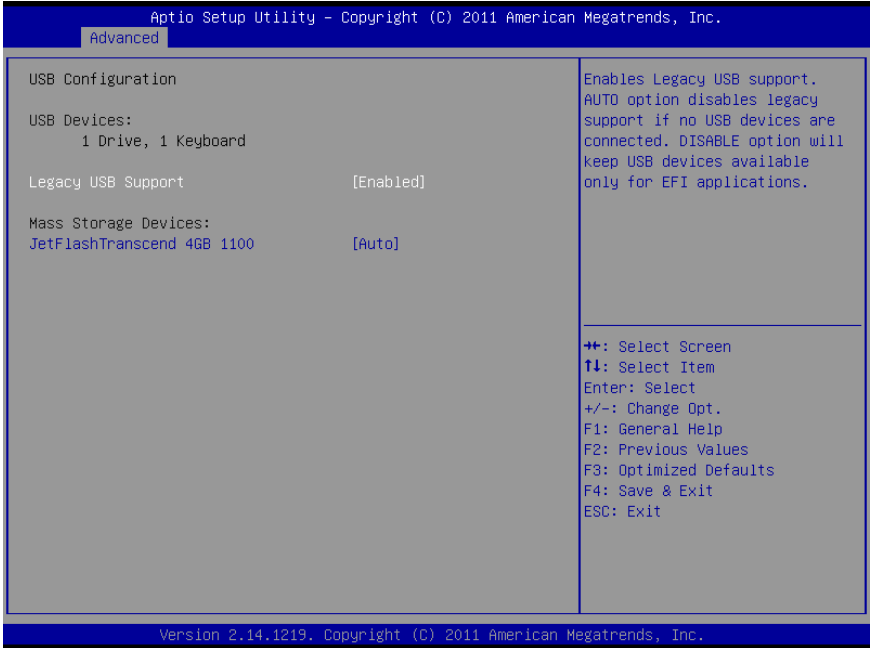

Options summary: **(default setting)**

Legacy USB Support	Enabled	
	Disabled	
	Auto	
Enables BIOS Support for Legacy USB Support. When enabled, USB can be functional in legacy environment like DOS. AUTO option disables legacy support if no USB devices are connected. DISABLE option will keep USB devices available only for EFI application		
Device Name	Auto	

(Emulation Type)	Floppy	
	Forced FDD	
	Hard Disk	
	CD-ROM	
If Auto. USB devices less than 530MB will be emulated as Floppy and remaining as Floppy and remaining as hard drive. Forced FDD option can be used to force a HDD formatted drive to boot as FDD(Ex. ZIP drive)		

3.4.5 Advanced: Super IO Configuration

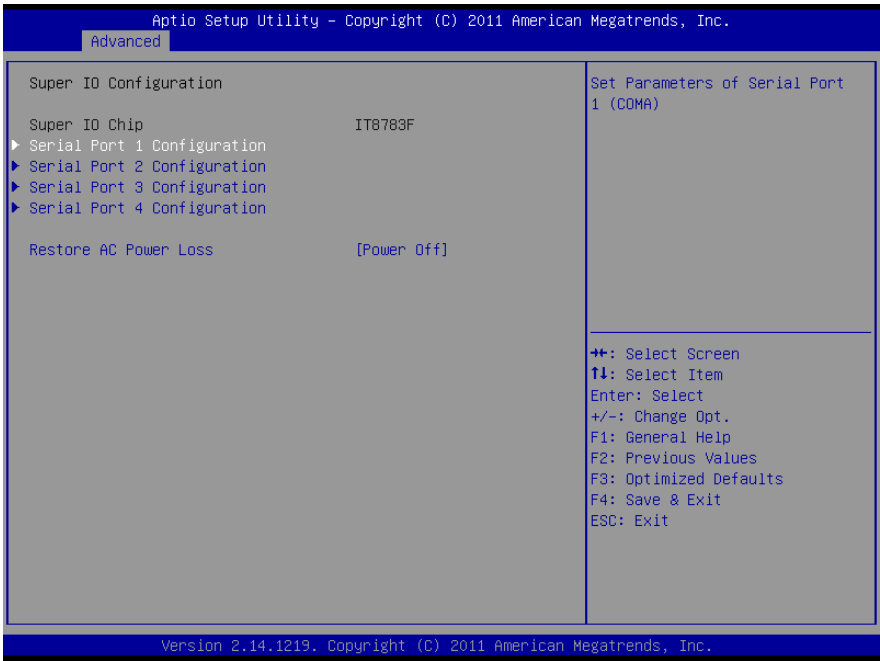

Options summary: **(default setting)**

Serial Port x Configuration		
Set Parameters of Serial Port x		
Parallel Port Configuration		
Set Parallel Port Configuration		
Restore AC Power Loss	Power off	
	Power on	
	Last State	
Set Power on after power fail function		

3.4.5.1 Super IO Configuration: Serial Port 2 Configuration

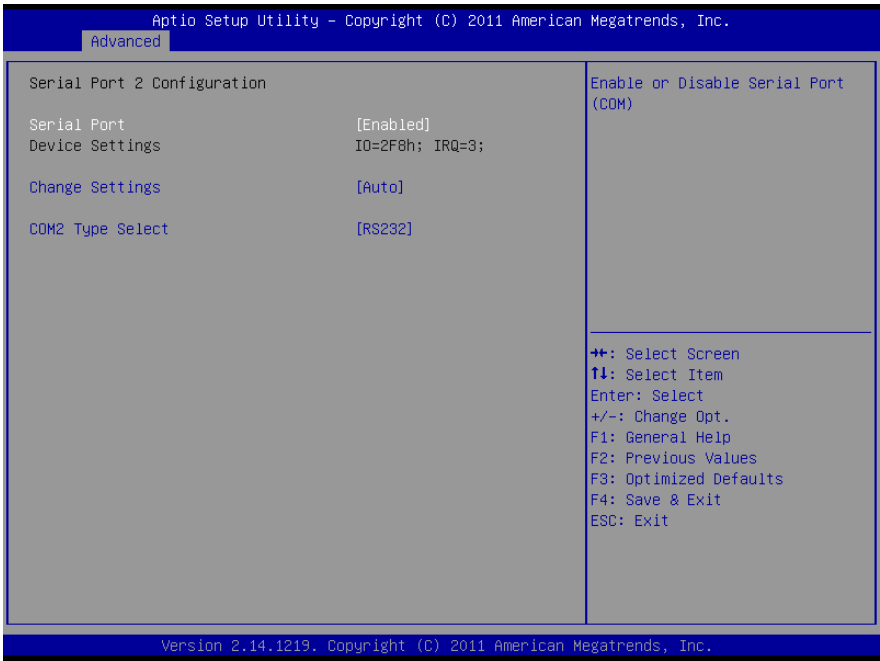

Options summary: **(default setting)**

Serial Port	Disabled	
	Enabled	
En/Disable specified serial port.		
Change Settings	Auto	
	IO=2F8h; IRQ=3;	
	IO=3F8h; IRQ=3,4,5,7,10,11,12;	
	IO=2F8h; IRQ=3,4,5,7,10,11,12;	
	IO=3E8h; IRQ=3,4,5,7,10,11,12;	
	IO=2E8h; IRQ=3,4,5,7,10,11,12;	
Select a resource setting for Super IO device.		

COM2 Type Option	RS232	
	RS422	
	RS485	

Configure COM2 operated as RS232, RS422 or RS485.

3.4.6 Advanced: Smart Fan Function

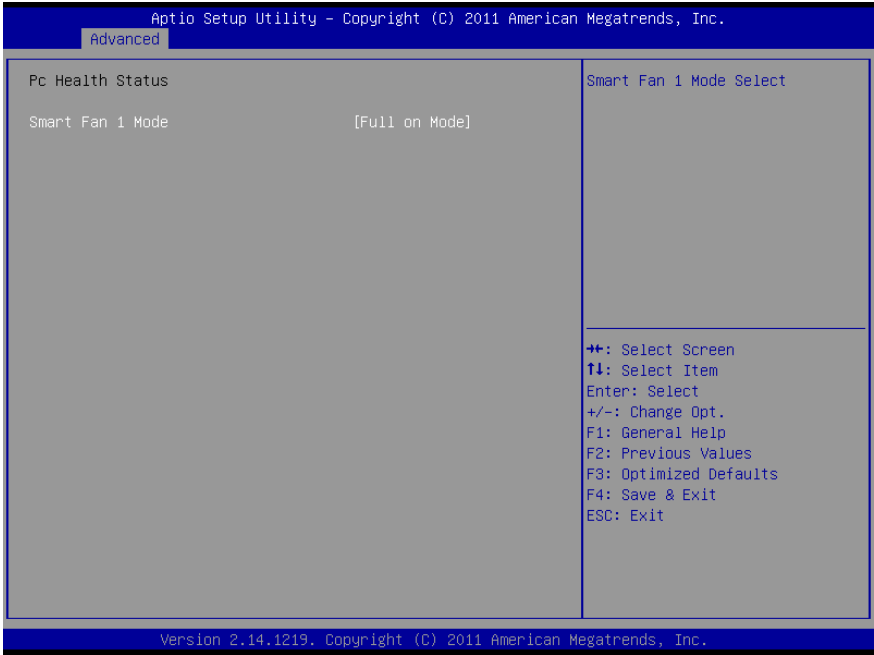

Options summary: **(default setting)**

Smart Fan 1 Mode	Full on mode	
	Automatic Mode	
	Manual Mode	
Smart Fan 1 Mode Select		

3.4.7 Advanced: H/W Monitor

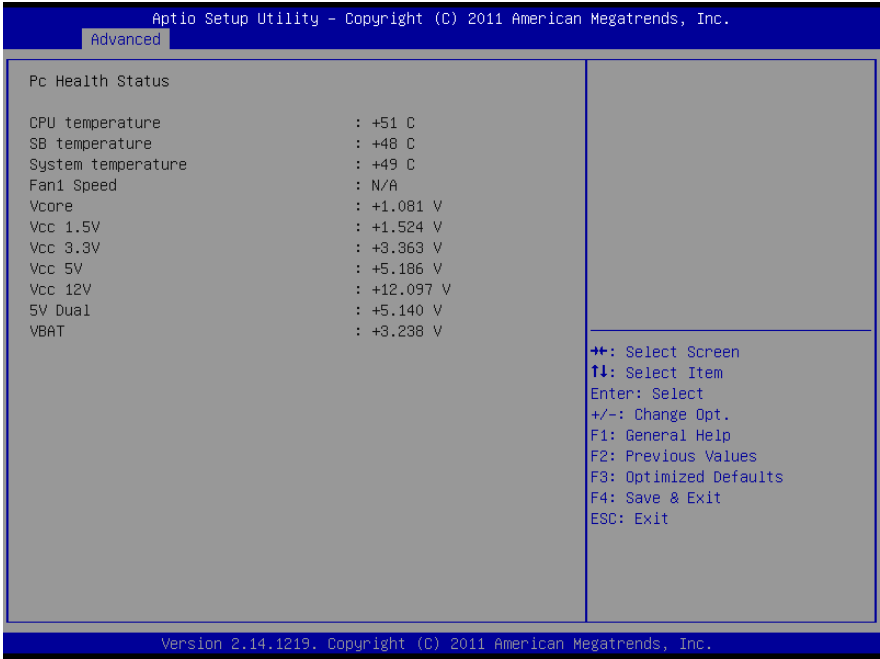

3.5 Setup submenu: Chipset

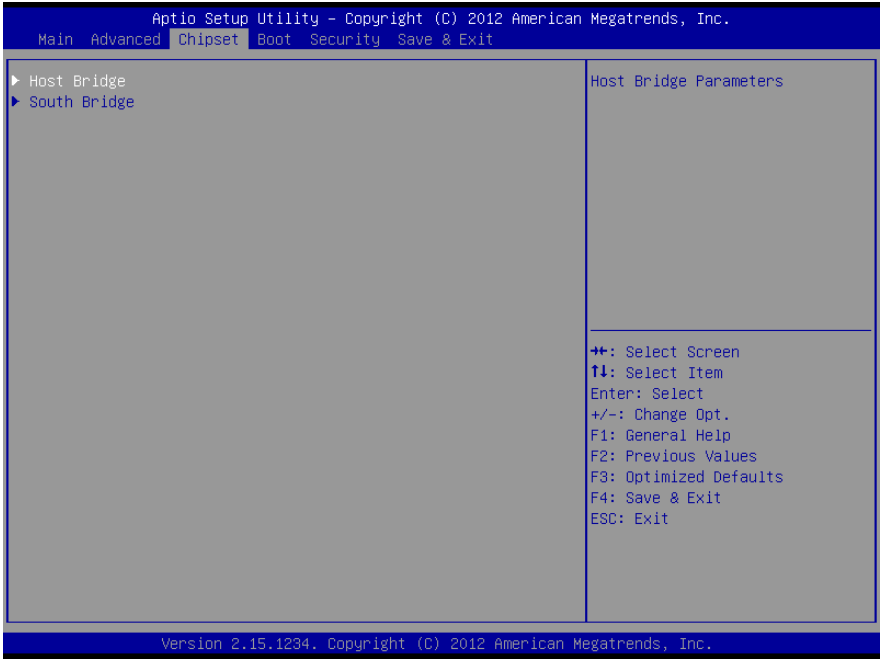

Options summary: **(default setting)**

Host Bridge		
Host Bridge Parameters		
South Bridge		
South Bridge Parameters		

3.5.1 Chipset: Host Bridge

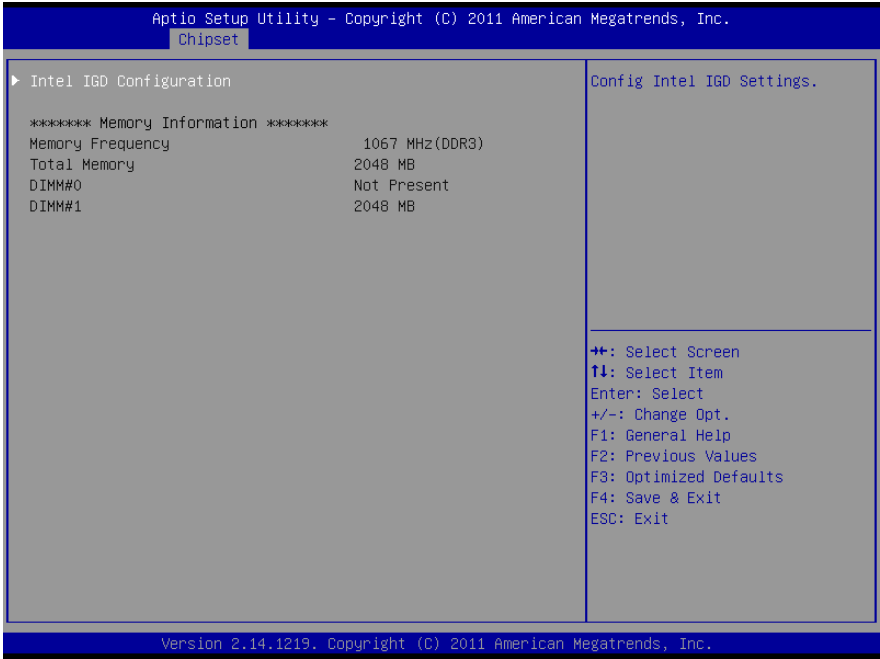

Options summary: **(default setting)**

Intel IGD Configuration		
Enter to set Graphic Configuration		
Memory Information		
Show current memory information		

3.5.1.1 Chipset: IGD Configuration

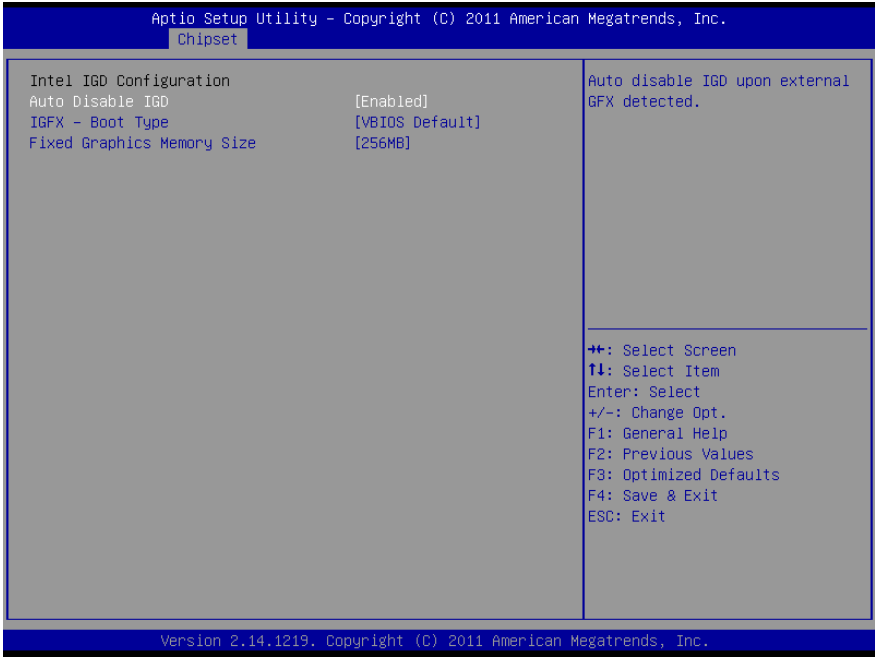

Options summary: **(default setting)**

Auto Disable IGD	Disabled	
	Enabled	
Support Auto Disable IGD		
IGFX – Boot Type	VBIOS Default	
Select the Video Device which will be activated during POST		
Fixed Graphics Memory Size	128MB	
	256MB	
Configure Fixed Graphics Memory Size		

3.5.2 Chipset: South Bridge

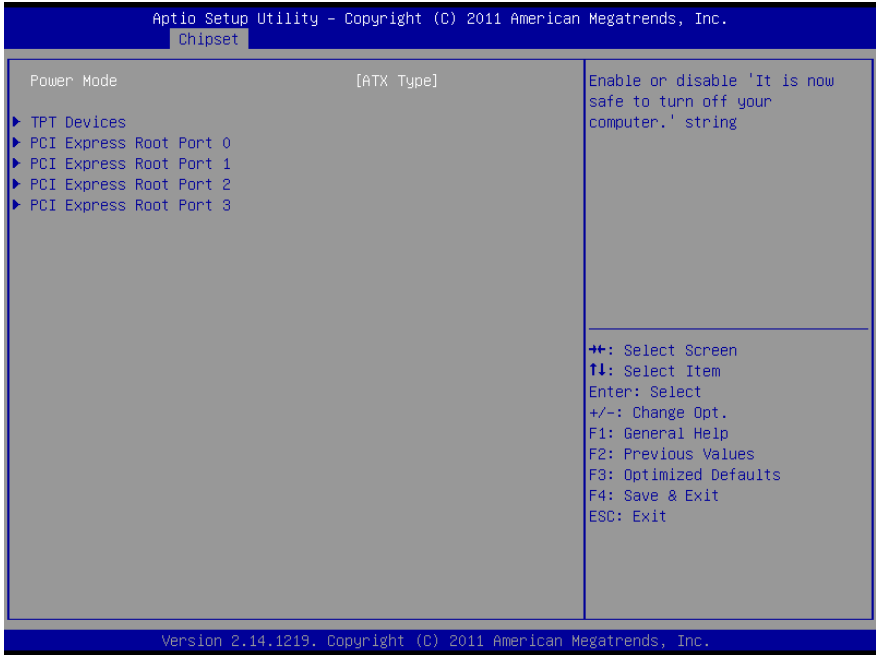

Options summary: **(default setting)**

Power Mode		
Select AT/ATX Power Mode		
TPT Devices		
Configure onboard TPT Devices		
PCI Express Port x	Disabled	
	Enabled	
Enable/Disable PCI Express Port 0 - 3		

3.5.2.1 South Bridge: TPT Devices

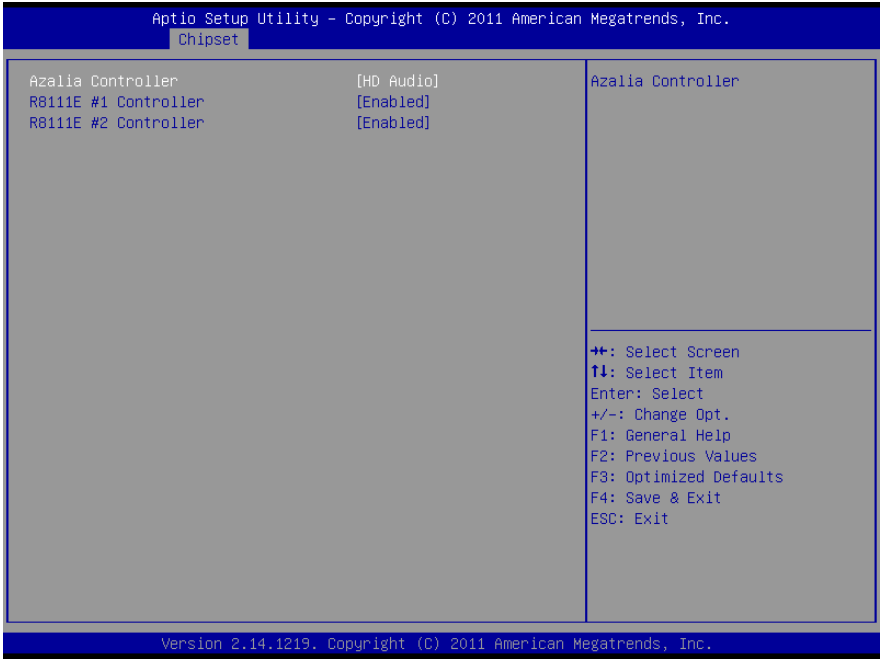

Options summary: (default setting)

Azalia Controller	Disabled	
	HD Audio	
Azalia Controller Enable/Disable		
R8111E #x Controller	Disabled	
	Enabl	
R8111E Enable/Disable		

3.6 Setup submenu: Boot

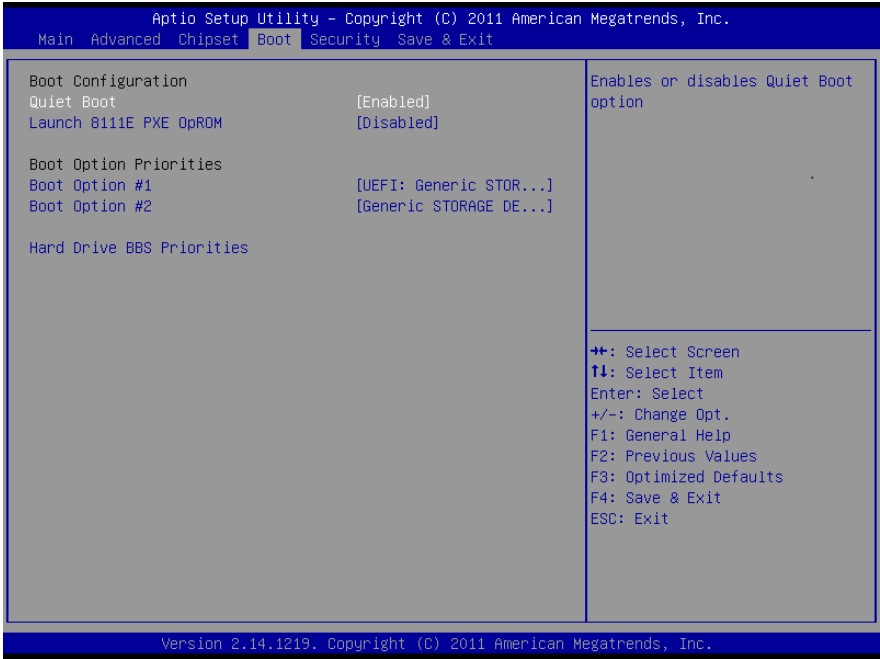

Options summary: (default setting)

Quiet Boot	Disabled	
	Enabled	
Enables or disables Quiet Boot option		
Launch 8111E PXE OpROM	Disabled	
	Enabled	
En/Disable PXE boot for onboard 8111E LAN		
Boot Option #X		
XXXX Drive BBS Priorities		
The order of boot priorities.		

3.6.1 Boot: BBS Priorities

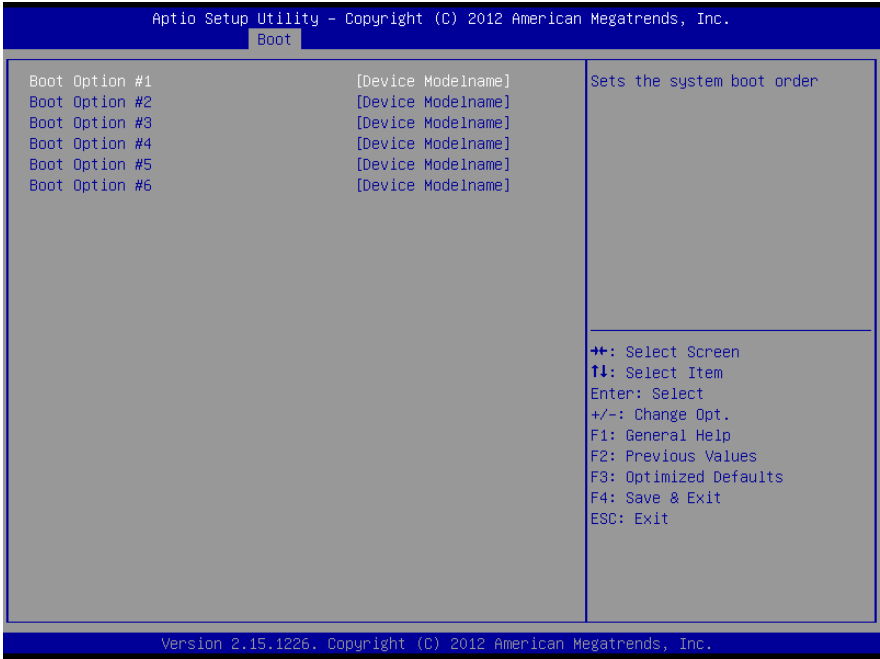

Options summary: (default setting)

Boot Option #x	Disabled	
	Device name	
Sets the system boot order		

3.7 Security

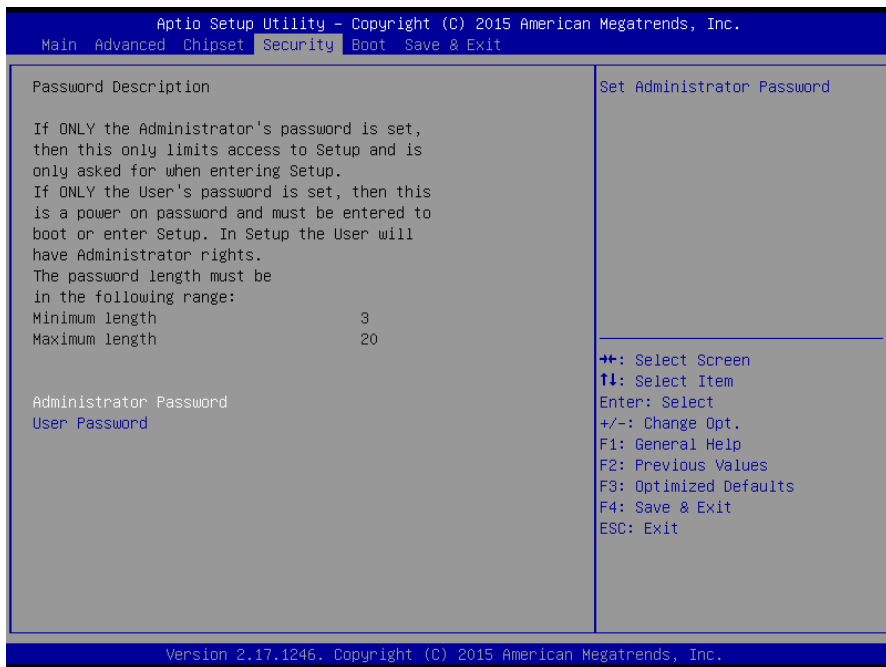

Options summary: (default setting)

Administrator Password/	Not set
User Password	

Change User/Administrator Password

You can set a User Password once an Administrator Password is set. The password will be required during boot up, or when the user enters the Setup utility. Please Note that a User Password does not provide access to many of the features in the Setup utility.

Select the password you wish to set, press Enter to open a dialog box to enter your password (you can enter no more than six letters or numbers). Press Enter to confirm your entry, after which you will be prompted to retype your password for a final

confirmation. Press Enter again after you have retyped it correctly.

Removing the Password

Highlight this item and type in the current password. At the next dialog box press Enter to disable password protection.

3.7.1 Security: HDD Security

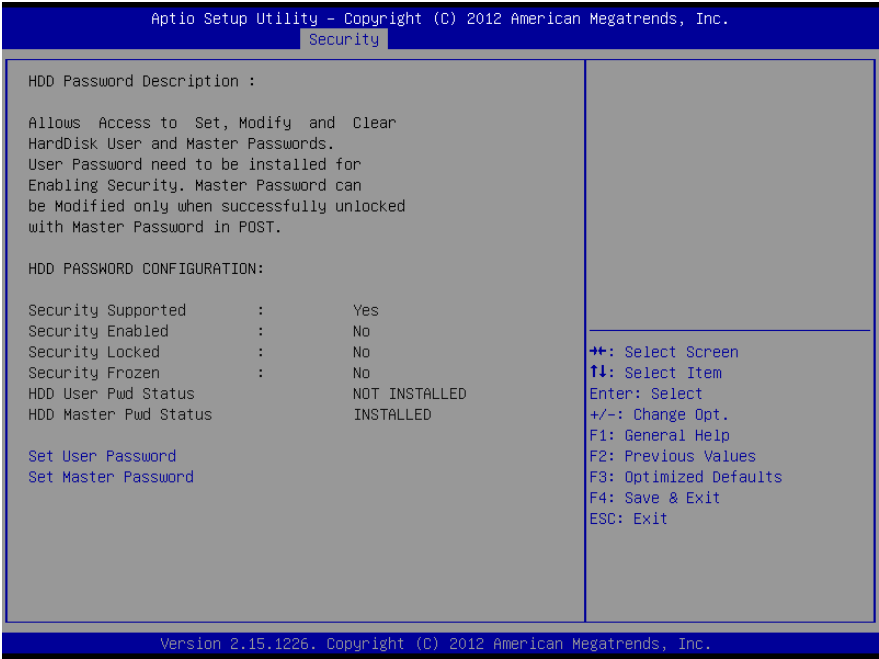

Options summary: (default setting)

Set User Password/	Not set
Set Master Password	

Before booting to OS, HDD will be set to a frozen state. On S3 resume HDD will be unlocked using the HDD Password we entered while system booting.

Select the password you wish to set, press Enter to open a dialog box to enter your password (you can enter no more than six letters or numbers). Press Enter to confirm your entry, after which you will be prompted to retype your password for a final confirmation. Press Enter again after you have retyped it correctly.

Removing the Password

Highlight this item and type in the current password. At the next dialog box press Enter to disable password protection.

3.8 Setup submenu: Save & Exit

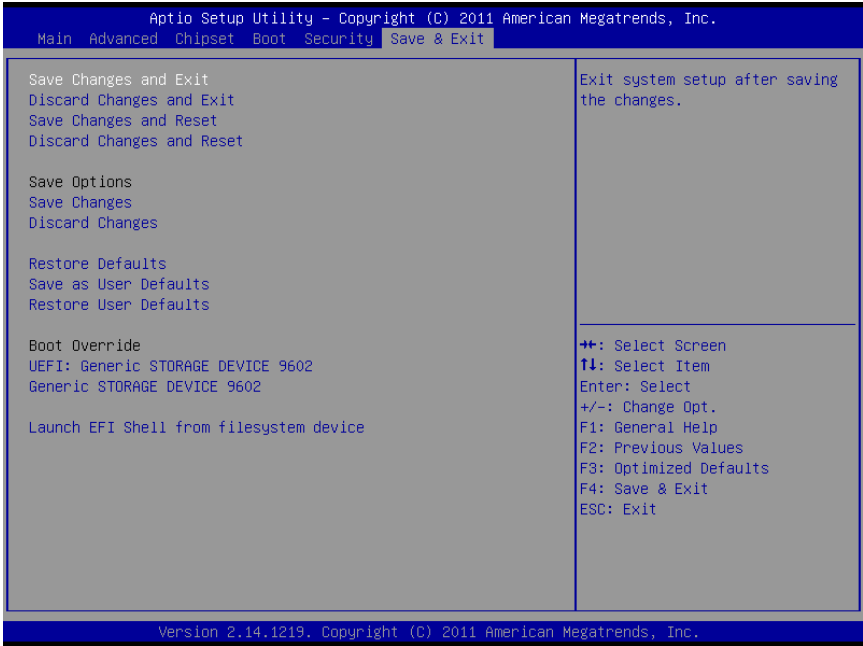

Options summary: **(default setting)**

Save Changes and Reset		
Reset the system after saving the changes		
Discard Changes and Reset		
Reset system setup without saving any changes		
Restore Defaults		
Restore/Load Default values for all the setup options.		
Save as User Defaults		
Save the changes done so far as User Defaults		
Restore User Defaults		
Restore the User Defaults to all the setup options		

Chapter 4

Drivers Installation

4.1 Product CD/DVD

The AEC-6613 comes with a product DVD that contains all the drivers and utilities you need to setup your product. Insert the DVD and follow the steps in the autorun program to install the drivers.

In case the program does not start, follow the sequence below to install the drivers.

Step 1 – Install Chipset Driver

1. Open the **STEP1 - Chipset** folder and select your OS
2. Open the **.exe** file in the folder
3. Follow the instructions
4. Drivers will be installed automatically

Step 2 – Install Graphic Driver

1. Open the **STEP2 - VGA** folder and select your OS
2. Open the **.exe/cmd** file in the folder
3. Follow the instructions
4. Drivers will be installed automatically

Step 3 – Install LAN Driver

1. Open the **STEP3 – LAN** folder and select your OS
2. Open the **setup.exe** file in the folder
3. Follow the instructions
4. Drivers will be installed automatically

Step 4 – Install Audio Driver

1. Open the **STEP4 - Audio** folder and select your OS
2. Open the **Setup.exe** file in the folder
3. Follow the instructions
4. Drivers will be installed automatically

Step 5 – Install RAID & AHCI Driver

Please refer to Appendix C

Step 6 – Install Serial Port Driver (Optional)

1. Open the **STEP6 – Serial Port Driver (Optional)** folder and select your OS
2. Open the **.exe** file in the folder
3. Follow the instructions
4. Drivers will be installed automatically

Note: If you are using a Chinese version of Windows, install the **Serial Patch v1.0.1** first

Appendix A

Watchdog Timer Programming

A.1 Watchdog Timer Programming

AEC-6613 utilizes the ITE 8783 chipset as its watchdog timer controller. Below are the procedures to complete its configuration and the AAeon initial watchdog timer program is also attached based on which you can develop customized program to fit your application.

Configuring Sequence Description

After the hardware reset or power-on reset, the ITE 8783 enters the normal mode with all logical devices disabled except KBC. The initial state (enable bit) of this logical device (KBC) is determined by the state of pin 121 (DTR1#) at the falling edge of the system reset during power-on reset.

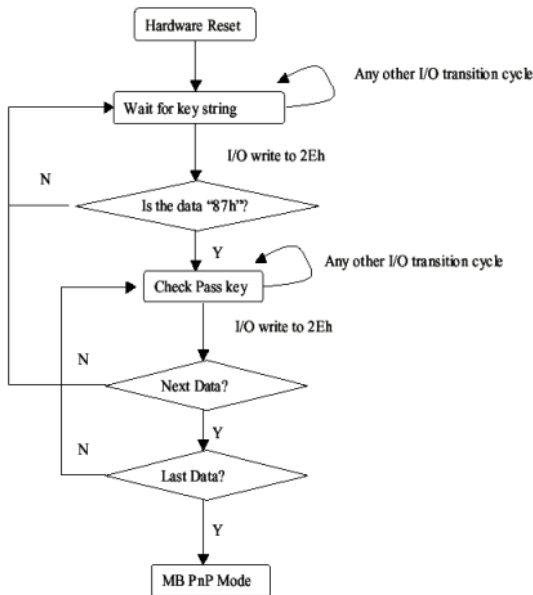

There are three steps to complete the configuration setup: (1) Enter the MB PnP Mode; (2) Modify the data of configuration registers; (3) Exit the MB PnP Mode. Undesired result may occur if the MB PnP Mode is not exited normally.

(1) Enter the MB PnP Mode

To enter the MB PnP Mode, four special I/O write operations are to be performed during Wait for Key state. To ensure the initial state of

the key-check logic, it is necessary to perform four write operations to the Special Address port (2EH). Two different enter keys are provided to select configuration ports (2Eh/2Fh) of the next step.

	Address Port	Data Port
87h, 01h, 55h, 55h:	2Eh	2Fh

(2) Modify the Data of the Registers

All configuration registers can be accessed after entering the MB PnP Mode. Before accessing a selected register, the content of Index 07h must be changed to the LDN to which the register belongs, except some Global registers.

(3) Exit the MB PnP Mode

Set bit 1 of the configure control register (Index=02h) to 1 to exit the MB PnP Mode.

WatchDog Timer Configuration Registers

LDN	Index	R/W	Reset	Configuration Register or Action
All	02h	W	NA	Configure Control

07h	71h	R/W	00h	Watch Dog Timer Control Register
07h	72h	R/W	001s0000b	Watch Dog Timer Configuration Register
07h	73h	R/W	38h	Watch Dog Timer Time-out Value (LSB) Register
07h	74h	R/W	00h	Watch Dog Timer Time-out Value (MSB) Register

Configure Control (Index=02h)

This register is write only. Its values are not sticky; that is to say, a hardware reset will automatically clear the bits, and does not require the software to clear them.

Bit	Description
7-2	Reserved
1	Returns to the "Wait for Key" state. This bit is used when the configuration sequence is completed.
0	Resets all logical devices and restores configuration registers to their power-on states.

Watch Dog Timer 1, 2, 3 Control Register (Index=71h,81h,91h Default=00h)

Bit	Description
7	WDT Timeout Enable(WTE) 1: Disable. 0: Enable.
6	WDT Reset upon Mouse Interrupt(WRKMI) 0: Disable. 1: Enable.
5	WDT Reset upon Keyboard Interrupt(WRKBI) 0: Disable. 1: Enable.
4	Reserved
3-2	Reserved
1	Force Time-out(FTO) This bit is self-clearing.
0	WDT Status(WS) 1: WDT value reaches 0. 0: WDT value is not 0.

Watch Dog Timer 1, 2, 3 Configuration Register (Index=72h, 82h, 92h Default=001s0000b)

Bit	Description
7	WDT Time-out Value Select 1 (WTVS) 1: Second 0: Minute
6	WDT Output through KRST (Pulse) Enable(WOKE) 1: Enable 0: Disable
5	WDT Time-out value Extra select(WTVES) 1: 64ms x WDT Timer-out value (default = 4s) 0: Determined by WDT Time-out value select 1 (bit 7 of this register)
4	WDT Output through PWROK (Pulse) Enable(WOPE) 1: Enable 0: Disable During LRESET#, this bit is selected by JP7 power-on strapping option
3-0	Select interrupt level ^{Note1} for WDT(SIL)

Watch Dog Timer 1,2,3 Time-Out Value (LSB) Register (Index=73h,83h,93h, Default=38h)

Bit	Description
7-0	WDT Time-out Value 7-0(WTV)

Watch Dog Timer 1,2,3 Time-Out Value (MSB) Register (Index=74h,84h,94h
Default=00h)

Bit	Description
7-0	WDT Time-out Value 15-8(WTV)

A.2 ITE8783 Watchdog Timer Initial Program

```
.MODEL SMALL
.CODE
Main:
CALL Enter_Configuration_mode
CALL Check_Chip
mov cl, 7
call Set_Logic_Device
;time setting
mov cl, 10 ; 10 Sec
dec al
Watch_Dog_Setting:
;Timer setting
mov al, cl
mov cl, 73h
call Superio_Set_Reg
;Clear by keyboard or mouse interrupt
mov al, 0f0h
mov cl, 71h
call Superio_Set_Reg
;unit is second.
mov al, 0C0H
mov cl, 72h
call Superio_Set_Reg
; game port enable
mov cl, 9
call Set_Logic_Device
```

Initial_OK:

CALL Exit_Configuration_mode

MOV AH,4Ch

INT 21h

Enter_Configuration_Mode PROC NEAR

MOV SI,WORD PTR CS:[Offset Cfg_Port]

MOV DX,02Eh

MOV CX,04h

Init_1:

MOV AL,BYTE PTR CS:[SI]

OUT DX,AL

INC SI

LOOP Init_1

RET

Enter_Configuration_Mode ENDP

Exit_Configuration_Mode PROC NEAR

MOV AX,0202h

CALL Write_Configuration_Data

RET

Exit_Configuration_Mode ENDP

Check_Chip PROC NEAR

MOV AL,20h

CALL Read_Configuration_Data

CMP AL,87h

JNE Not_Initial

MOV AL,21h

CALL Read_Configuration_Data

CMP AL,81h

JNE Not_Initial

Need_Initial:

STC

RET

Not_Initial:

CLC

RET

Check_Chip ENDP

Read_Configuration_Data PROC NEAR

MOV DX,WORD PTR CS:[Cfg_Port+04h]

OUT DX,AL

MOV DX,WORD PTR CS:[Cfg_Port+06h]

IN AL,DX

RET

Read_Configuration_Data ENDP

Write_Configuration_Data PROC NEAR

MOV DX,WORD PTR CS:[Cfg_Port+04h]

OUT DX,AL

XCHG AL,AH

```
MOV DX,WORD PTR CS:[Cfg_Port+06h]
OUT DX,AL
RET
Write_Configuration_Data ENDP
```

```
Superio_Set_Reg proc near
push ax
MOV DX,WORD PTR CS:[Cfg_Port+04h]
mov al,cl
out dx,al
pop ax
inc dx
out dx,al
ret
Superio_Set_Reg endp.Set_Logic_Device proc near
Set_Logic_Device proc near
push ax
push cx
xchg al,cl
mov cl,07h
call Superio_Set_Reg
pop cx
pop ax
ret
Set_Logic_Device endp
```

;Select 02Eh->Index Port, 02Fh->Data Port

Cfg_Port DB 087h,001h,055h,055h

DW 02Eh,02Fh

END Main

Note: Interrupt level mapping

0Fh-Dh: not valid

0Ch: IRQ12

.

.

03h: IRQ3

02h: not valid

01h: IRQ1

00h: no interrupt selected







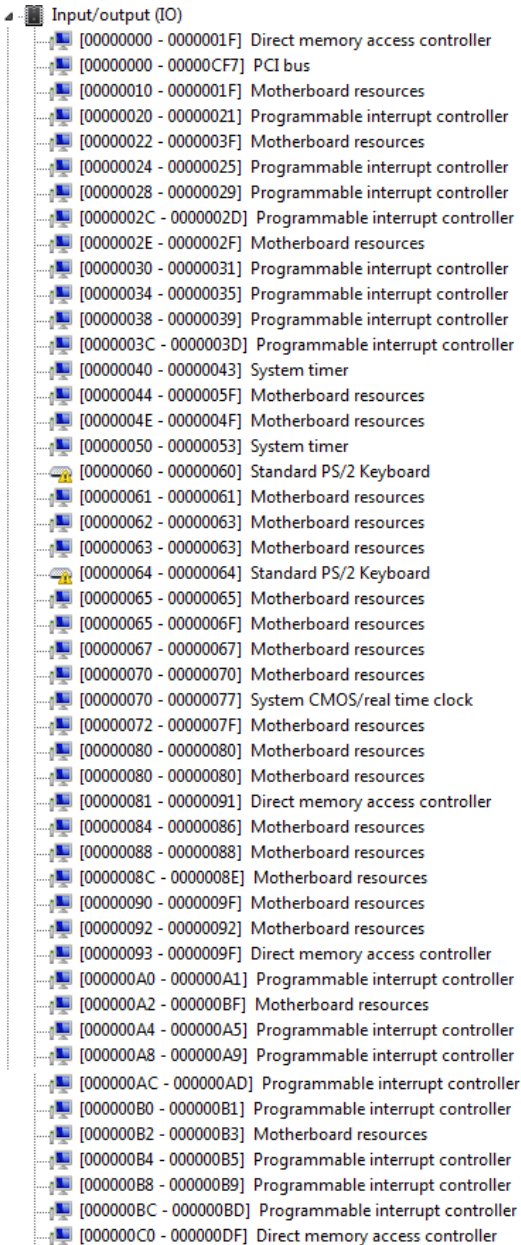



































Appendix B

I/O Information

B.1 I/O Address Map



Address Range	Device Name
[00000000 - 0000001F]	Direct memory access controller
[00000000 - 00000CF7]	PCI bus
[00000010 - 0000001F]	Motherboard resources
[00000020 - 00000021]	Programmable interrupt controller
[00000022 - 0000003F]	Motherboard resources
[00000024 - 00000025]	Programmable interrupt controller
[00000028 - 00000029]	Programmable interrupt controller
[0000002C - 0000002D]	Programmable interrupt controller
[0000002E - 0000002F]	Motherboard resources
[00000030 - 00000031]	Programmable interrupt controller
[00000034 - 00000035]	Programmable interrupt controller
[00000038 - 00000039]	Programmable interrupt controller
[0000003C - 0000003D]	Programmable interrupt controller
[00000040 - 00000043]	System timer
[00000044 - 0000005F]	Motherboard resources
[0000004E - 0000004F]	Motherboard resources
[00000050 - 00000053]	System timer
[00000060 - 00000060]	Standard PS/2 Keyboard
[00000061 - 00000061]	Motherboard resources
[00000062 - 00000063]	Motherboard resources
[00000063 - 00000063]	Motherboard resources
[00000064 - 00000064]	Standard PS/2 Keyboard
[00000065 - 00000065]	Motherboard resources
[00000065 - 0000006F]	Motherboard resources
[00000067 - 00000067]	Motherboard resources
[00000070 - 00000070]	Motherboard resources
[00000070 - 00000077]	System CMOS/real time clock
[00000072 - 0000007F]	Motherboard resources
[00000080 - 00000080]	Motherboard resources
[00000080 - 00000080]	Motherboard resources
[00000081 - 00000091]	Direct memory access controller
[00000084 - 00000086]	Motherboard resources
[00000088 - 00000088]	Motherboard resources
[0000008C - 0000008E]	Motherboard resources
[00000090 - 0000009F]	Motherboard resources
[00000092 - 00000092]	Motherboard resources
[00000093 - 0000009F]	Direct memory access controller
[000000A0 - 000000A1]	Programmable interrupt controller
[000000A2 - 000000BF]	Motherboard resources
[000000A4 - 000000A5]	Programmable interrupt controller
[000000A8 - 000000A9]	Programmable interrupt controller
[000000AC - 000000AD]	Programmable interrupt controller
[000000B0 - 000000B1]	Programmable interrupt controller
[000000B2 - 000000B3]	Motherboard resources
[000000B4 - 000000B5]	Programmable interrupt controller
[000000B8 - 000000B9]	Programmable interrupt controller
[000000BC - 000000BD]	Programmable interrupt controller
[000000C0 - 000000DF]	Direct memory access controller





















































	[000000E0 - 000000EF]	Motherboard resources
	[000000F0 - 000000F0]	Numeric data processor
	[000002E0 - 000002E7]	Communications Port (COM6)
	[000002E8 - 000002EF]	Communications Port (COM4)
	[000002F0 - 000002F7]	Communications Port (COM5)
	[000002F8 - 000002FF]	Communications Port (COM2)
	[00000378 - 0000037F]	Printer Port (LPT1)
	[000003B0 - 000003BB]	Intel(R) Graphics Media Accelerator 3600 Series
	[000003C0 - 000003DF]	Intel(R) Graphics Media Accelerator 3600 Series
	[000003E8 - 000003EF]	Communications Port (COM3)
	[000003F8 - 000003FF]	Communications Port (COM1)
	[00000400 - 0000047F]	Motherboard resources
	[00000400 - 0000047F]	Motherboard resources
	[000004D0 - 000004D1]	Motherboard resources
	[000004D0 - 000004D1]	Programmable interrupt controller
	[00000500 - 0000053F]	Motherboard resources
	[00000500 - 0000057F]	Motherboard resources
	[00000600 - 0000061F]	Motherboard resources
	[00000680 - 0000069F]	Motherboard resources
	[000006A0 - 000006AF]	Motherboard resources
	[000006B0 - 000006EF]	Motherboard resources
	[00000A00 - 00000A1F]	Motherboard resources
	[00000A20 - 00000A2F]	Motherboard resources
	[00000A30 - 00000A3F]	Motherboard resources
	[00000D00 - 0000FFFF]	PCI bus
	[00001000 - 0000100F]	Motherboard resources
	[0000D000 - 0000D0FF]	Realtek PCIe GBE Family Controller #2
	[0000D000 - 0000DFFF]	Intel(R) N10/ICH7 Family PCI Express Root Port - 27D2
	[0000E000 - 0000E0FF]	Realtek PCIe GBE Family Controller
	[0000E000 - 0000EFFF]	Intel(R) N10/ICH7 Family PCI Express Root Port - 27D0
	[0000F000 - 0000F01F]	Intel(R) N10/ICH7 Family SMBus Controller - 27DA
	[0000F020 - 0000F02F]	Intel(R) NM10 Express Chipset
	[0000F040 - 0000F05F]	Intel(R) N10/ICH7 Family USB Universal Host Controller - 27CB
	[0000F060 - 0000F07F]	Intel(R) N10/ICH7 Family USB Universal Host Controller - 27CA
	[0000F080 - 0000F09F]	Intel(R) N10/ICH7 Family USB Universal Host Controller - 27C9
	[0000F0A0 - 0000F0BF]	Intel(R) N10/ICH7 Family USB Universal Host Controller - 27C8
	[0000F0C0 - 0000F0C3]	Intel(R) NM10 Express Chipset
	[0000F0D0 - 0000F0D7]	Intel(R) NM10 Express Chipset
	[0000F0E0 - 0000F0E3]	Intel(R) NM10 Express Chipset
	[0000F0F0 - 0000F0F7]	Intel(R) NM10 Express Chipset
	[0000F100 - 0000F107]	Intel(R) Graphics Media Accelerator 3600 Series
	[0000FFFF - 0000FFFF]	Motherboard resources
	[0000FFFF - 0000FFFF]	Motherboard resources

B.2 1st Memory Address Map

Address Range	Device Name
[00000000 - 00000FFF]	Motherboard resources
[00000000 - 00000FFF]	Motherboard resources
[00000000 - 00003FFF]	Motherboard resources
[000A0000 - 000BFFFF]	Intel(R) Graphics Media Accelerator 3600 Series
[000A0000 - 000BFFFF]	PCI bus
[000C0000 - 000DFFFF]	PCI bus
[000E0000 - 000EFFFF]	PCI bus
[000F0000 - 000FFFFF]	PCI bus
[3F800000 - 3FFFFFFF]	PCI bus
[40000000 - FEBFFFFF]	PCI bus
[DFC00000 - DFCFFFFF]	Intel(R) Graphics Media Accelerator 3600 Series
[DFD00000 - DFD03FFF]	Realtek PCIe GBE Family Controller #2
[DFD00000 - DFD0FFFF]	Intel(R) N10/ICH7 Family PCI Express Root Port - 27D2
[DFD04000 - DFD04FFF]	Realtek PCIe GBE Family Controller #2
[DFE00000 - DFE03FFF]	Realtek PCIe GBE Family Controller
[DFE00000 - DFE0FFFF]	Intel(R) N10/ICH7 Family PCI Express Root Port - 27D0
[DFE04000 - DFE04FFF]	Realtek PCIe GBE Family Controller
[DFF00000 - DFF03FFF]	High Definition Audio Controller
[DFF04000 - DFF043FF]	Intel(R) NM10 Express Chipset
[DFF05000 - DFF053FF]	Intel(R) N10/ICH7 Family USB2 Enhanced Host Controller - 27CC
[E0000000 - EFFFFFFF]	System board
[FEC00000 - FEC00FFF]	Motherboard resources
[FED00000 - FED003FF]	High precision event timer
[FED14000 - FED19FFF]	System board
[FED1C000 - FED1FFFF]	Motherboard resources
[FED1C000 - FED1FFFF]	Motherboard resources
[FED20000 - FED8FFFF]	Motherboard resources
[FED45000 - FED8FFFF]	Motherboard resources
[FEE00000 - FEE0FFFF]	Motherboard resources
[FF000000 - FFFFFFFF]	Intel(R) 82802 Firmware Hub Device
[FF000000 - FFFFFFFF]	Intel(R) 82802 Firmware Hub Device
[FFC00000 - FFFFFFFF]	Motherboard resources

B.3 IRQ Mapping Chart

Device	IRQ
System timer	(00)
Standard PS/2 Keyboard	(01)
Communications Port (COM2)	(03)
Communications Port (COM1)	(04)
Communications Port (COM5)	(05)
Communications Port (COM6)	(07)
System CMOS/real time clock	(08)
Communications Port (COM3)	(10)
Communications Port (COM4)	(11)
Microsoft PS/2 Mouse	(12)
Numeric data processor	(13)
Microsoft ACPI-Compliant System	(81)
Microsoft ACPI-Compliant System	(82)
Microsoft ACPI-Compliant System	(83)
Microsoft ACPI-Compliant System	(84)
Microsoft ACPI-Compliant System	(85)
Microsoft ACPI-Compliant System	(86)
Microsoft ACPI-Compliant System	(87)
Microsoft ACPI-Compliant System	(88)
Microsoft ACPI-Compliant System	(89)
Microsoft ACPI-Compliant System	(90)
Microsoft ACPI-Compliant System	(91)
Microsoft ACPI-Compliant System	(92)
Microsoft ACPI-Compliant System	(93)
Microsoft ACPI-Compliant System	(94)
Microsoft ACPI-Compliant System	(95)
Microsoft ACPI-Compliant System	(96)
Microsoft ACPI-Compliant System	(97)
Microsoft ACPI-Compliant System	(98)
Microsoft ACPI-Compliant System	(99)
Microsoft ACPI-Compliant System	(100)
Microsoft ACPI-Compliant System	(101)
Microsoft ACPI-Compliant System	(102)
Microsoft ACPI-Compliant System	(103)
Microsoft ACPI-Compliant System	(104)
Microsoft ACPI-Compliant System	(105)
Microsoft ACPI-Compliant System	(106)
Microsoft ACPI-Compliant System	(107)
Microsoft ACPI-Compliant System	(108)
Microsoft ACPI-Compliant System	(109)
Microsoft ACPI-Compliant System	(110)
Microsoft ACPI-Compliant System	(111)
Microsoft ACPI-Compliant System	(112)
Microsoft ACPI-Compliant System	(113)
Microsoft ACPI-Compliant System	(114)
Microsoft ACPI-Compliant System	(115)
Microsoft ACPI-Compliant System	(116)
Microsoft ACPI-Compliant System	(117)
Microsoft ACPI-Compliant System	(118)
Microsoft ACPI-Compliant System	(119)
Microsoft ACPI-Compliant System	(120)
Microsoft ACPI-Compliant System	(121)
Microsoft ACPI-Compliant System	(122)
Microsoft ACPI-Compliant System	(123)
Microsoft ACPI-Compliant System	(124)
Microsoft ACPI-Compliant System	(125)
Microsoft ACPI-Compliant System	(126)
Microsoft ACPI-Compliant System	(127)
Microsoft ACPI-Compliant System	(128)
Microsoft ACPI-Compliant System	(129)
Microsoft ACPI-Compliant System	(130)

 (ISA) 0x00000083 (131)	Microsoft ACPI-Compliant System
 (ISA) 0x00000084 (132)	Microsoft ACPI-Compliant System
 (ISA) 0x00000085 (133)	Microsoft ACPI-Compliant System
 (ISA) 0x00000086 (134)	Microsoft ACPI-Compliant System
 (ISA) 0x00000087 (135)	Microsoft ACPI-Compliant System
 (ISA) 0x00000088 (136)	Microsoft ACPI-Compliant System
 (ISA) 0x00000089 (137)	Microsoft ACPI-Compliant System
 (ISA) 0x0000008A (138)	Microsoft ACPI-Compliant System
 (ISA) 0x0000008B (139)	Microsoft ACPI-Compliant System
 (ISA) 0x0000008C (140)	Microsoft ACPI-Compliant System
 (ISA) 0x0000008D (141)	Microsoft ACPI-Compliant System
 (ISA) 0x0000008E (142)	Microsoft ACPI-Compliant System
 (ISA) 0x0000008F (143)	Microsoft ACPI-Compliant System
 (ISA) 0x00000090 (144)	Microsoft ACPI-Compliant System
 (ISA) 0x00000091 (145)	Microsoft ACPI-Compliant System
 (ISA) 0x00000092 (146)	Microsoft ACPI-Compliant System
 (ISA) 0x00000093 (147)	Microsoft ACPI-Compliant System
 (ISA) 0x00000094 (148)	Microsoft ACPI-Compliant System
 (ISA) 0x00000095 (149)	Microsoft ACPI-Compliant System
 (ISA) 0x00000096 (150)	Microsoft ACPI-Compliant System
 (ISA) 0x00000097 (151)	Microsoft ACPI-Compliant System
 (ISA) 0x00000098 (152)	Microsoft ACPI-Compliant System
 (ISA) 0x00000099 (153)	Microsoft ACPI-Compliant System
 (ISA) 0x0000009A (154)	Microsoft ACPI-Compliant System
 (ISA) 0x0000009B (155)	Microsoft ACPI-Compliant System
 (ISA) 0x0000009C (156)	Microsoft ACPI-Compliant System
 (ISA) 0x0000009D (157)	Microsoft ACPI-Compliant System
 (ISA) 0x0000009E (158)	Microsoft ACPI-Compliant System
 (ISA) 0x0000009F (159)	Microsoft ACPI-Compliant System
 (ISA) 0x000000A0 (160)	Microsoft ACPI-Compliant System
 (ISA) 0x000000A1 (161)	Microsoft ACPI-Compliant System
 (ISA) 0x000000A2 (162)	Microsoft ACPI-Compliant System
 (ISA) 0x000000A3 (163)	Microsoft ACPI-Compliant System
 (ISA) 0x000000A4 (164)	Microsoft ACPI-Compliant System
 (ISA) 0x000000A5 (165)	Microsoft ACPI-Compliant System
 (ISA) 0x000000A6 (166)	Microsoft ACPI-Compliant System
 (ISA) 0x000000A7 (167)	Microsoft ACPI-Compliant System
 (ISA) 0x000000A8 (168)	Microsoft ACPI-Compliant System
 (ISA) 0x000000A9 (169)	Microsoft ACPI-Compliant System
 (ISA) 0x000000AA (170)	Microsoft ACPI-Compliant System
 (ISA) 0x000000A8 (171)	Microsoft ACPI-Compliant System
 (ISA) 0x000000AC (172)	Microsoft ACPI-Compliant System
 (ISA) 0x000000AD (173)	Microsoft ACPI-Compliant System
 (ISA) 0x000000AE (174)	Microsoft ACPI-Compliant System
 (ISA) 0x000000AF (175)	Microsoft ACPI-Compliant System
 (ISA) 0x000000B0 (176)	Microsoft ACPI-Compliant System
 (ISA) 0x000000B1 (177)	Microsoft ACPI-Compliant System
 (ISA) 0x000000B2 (178)	Microsoft ACPI-Compliant System
 (ISA) 0x000000B3 (179)	Microsoft ACPI-Compliant System
 (ISA) 0x000000B4 (180)	Microsoft ACPI-Compliant System
 (ISA) 0x000000B5 (181)	Microsoft ACPI-Compliant System
 (ISA) 0x000000B6 (182)	Microsoft ACPI-Compliant System
(ISA) 0x000000B7 (183)	Microsoft ACPI-Compliant System
(ISA) 0x000000B8 (184)	Microsoft ACPI-Compliant System
(ISA) 0x000000B9 (185)	Microsoft ACPI-Compliant System
(ISA) 0x000000BA (186)	Microsoft ACPI-Compliant System
(ISA) 0x000000BB (187)	Microsoft ACPI-Compliant System
(ISA) 0x000000BC (188)	Microsoft ACPI-Compliant System
(ISA) 0x000000BD (189)	Microsoft ACPI-Compliant System
(ISA) 0x000000BE (190)	Microsoft ACPI-Compliant System

B.4 DMA Channel Assignments

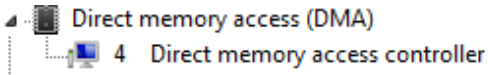

Appendix C

AHCI Settings

C.1 Setting AHCI

OS installation to setup AHCI mode

Step 1: Copy the files below from “Driver CD -> STEP5-AHCI\WIN7_32\F6 Install Floppy

Create for 32 and 64 bit Windows” to Disk



Step 2: Setup OS

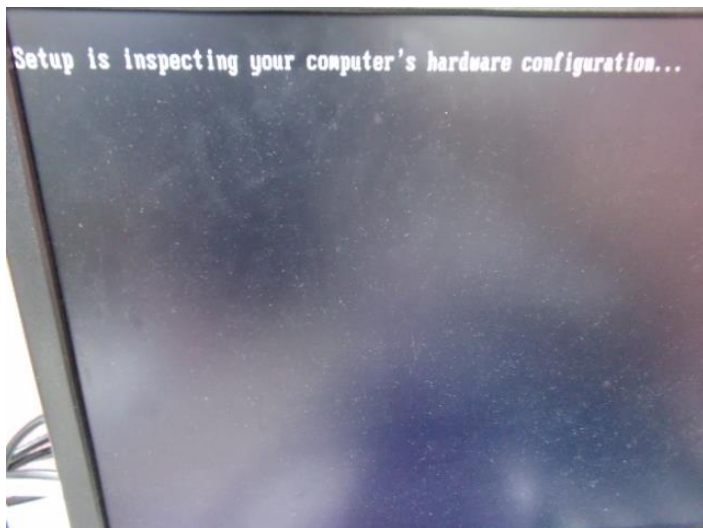

Step 3: Press "F6"



Step 4: Choose "S"



Step 5: Choose "Intel® NM10 Express Chipset"

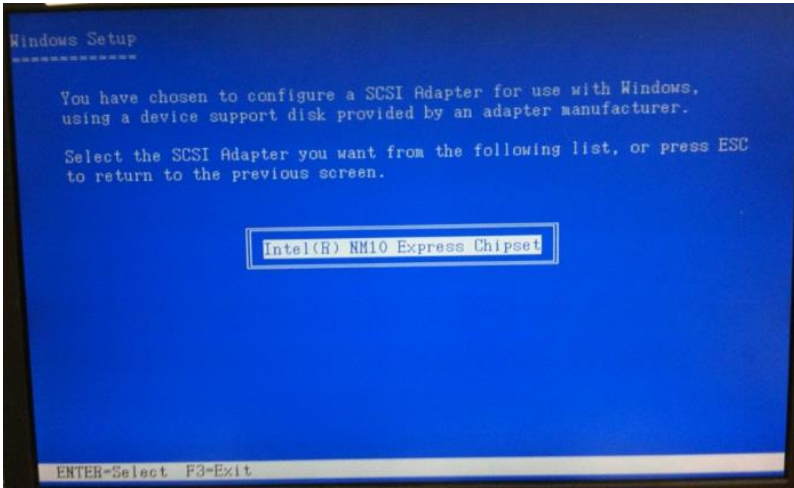

Step 6: It will show the model number you select and then press "ENTER"

Step 7: Setup is loading files

