

AMB-255A series

15" Industrial Display Monitors



▶ AMB-255A



▶ AMB-255AR

Introduction

The AMB-255A is a rugged 15" XGA (1024 x 768) color TFT display monitor built specifically for industrial applications. It displays brilliant, crisp and flicker-free images with an equivalent screen size of 17" traditional CRT monitors. With the optional touchscreen, the AMB-255A is an excellent and user-friendly system control interface.

The AMB-255A provides all the requirements for an analog RGB interface with a 15" XGA color TFT LCD display that can be directly connected to a standard VGA port, multi-scan function display in VGA, SVGA and text-mode full screen. The monitor is equipped with an On Screen Display (OSD) controller for adjusting the LCD. The chassis is constructed with an aluminum front panel and stainless steel chassis. This combination ensures a sturdy and corrosion resistant monitor and is NEMA 4/12 & IP65 compliant.

Features

- 15" XGA color TFT LCD display
- Heavy-duty stainless steel chassis and aluminum alloy front panel
- Front panel is NEMA 4/12 & IP65 compliant
- OSD (On Screen Display) function for display adjustment
- Strengthened glass protects the front panel from shock damage
- EIA RS-310C 19" rack-mount 8U height (optional)
- Analog RGB signal directly input offering multi-scan function
- RGB, Composite video AV signal selectable
- VGA cable length supports up to 20 Meters
- VESA 75mm standard screw holes
- Touchscreen (optional)

Specifications

- **Construction:** Heavy-duty stainless steel chassis & Aluminum alloy front panel meets NEMA4/12 & IP65
- **Front panel color:** RAL-7035 (white)
- **Mounting:** Panel mount or Rack mount
Optional : Swivel arm or Stand
- **Input signal:** RGB, Composite video
- **Control:** OSD (On Screen Display) on front panel
- **Power Supply:** External power adapter
- **Dimensions (W x H x D):**
AMB-255A: 420 x 300 x 55mm (16.5" x 11.8" x 2.2")
AMB-255AR: 483 x 311.5 x 55mm (19" x 12.3" x 2.2")
- **Carton dimensions (W x H x D):**
AMB-255A: 580 x 402 x 173mm (22.8" x 15.8" x 6.8")
AMB-255AR: 558 x 402 x 173mm (21.9" x 15.8" x 6.8")
- **Gross Weight:** 8.9Kg (19.6 lbs)

LCD Specification

Model	AMB-255A series
Display type	15" color TFT LCD
Max. resolution	1024 x 768
Max. colors	256K
Dot size (mm)	0.297 x 0.297
Luminance (cd/m ²)	250
Viewing angle	160° (H) 160° (V)
Operating temperature	0° ~50°C (32~122 °F)
OSD	Yes
LCD MTBF (Hrs)	50,000
Back Light MTBF (Hrs)	50,000

AMB-255A series

Environmental Specifications

- **Operating temperature:** 0° to 45°C (32~113°F)
- **Storage temperature:** -20° to 60°C (-4~140°F)
- **Storage humidity:** 10 to 95% @40°C, non-condensing
- **Vibration:**
1G / 5 ~ 500Hz / operation
- **Shock:** 10G peak acceleration (11 msec. duration)
- **EMI:** CE / FCC Class A

Touchscreen (optional)

Type: 8-wire, analog resistive

Resolution: 1024 x 1024

Light transmission: >68%

Lifetime: 1 million activations

Operating pressure: 90g average for finger, 70g average with non-metal stylus

Controller: RS-232 interface

OS support: MS DOS, Windows 3.1, Windows 95, Windows 98, Windows ME, Windows NT, Windows 2000

Ordering Information

- **AMB-255A**
15" TFT LCD, external power adapter and 1.2m VGA extension cable
- **AMB-255AT**
AMB-255A + touchscreen (RS-232 interface)
- **AMB-255AR**
15" TFT LCD, external power adapter and 1.2m VGA extension cable, with 19" rack-mount bezel
- **AMB-255ART**
AMB-255AR + touchscreen (RS-232 interface)
- **STAND-025500**
Desktop stand with VESA 75mm standards
- **ARM-LA0115** (refer to p.82)
Swivel arm with VESA 75/100mm standards

Dimension

AMB-255A

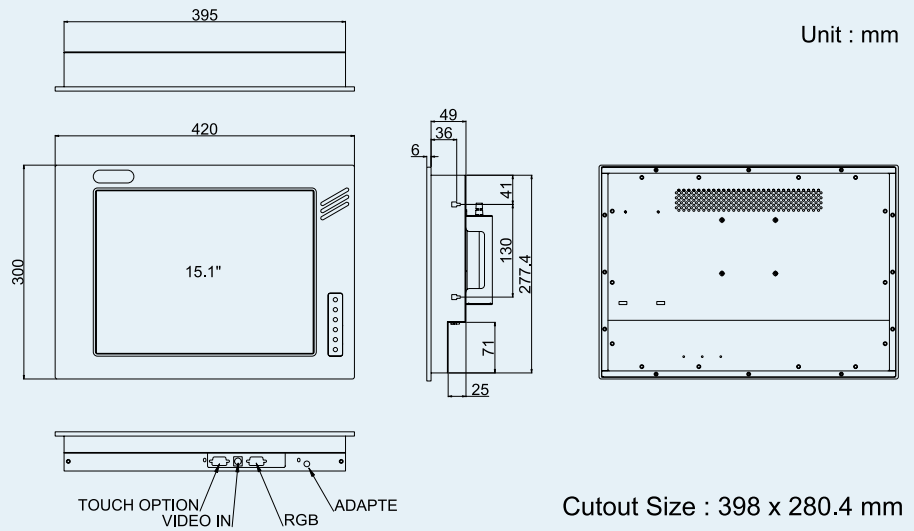

AMB-255AR

