

NETWORK PLATFORM SOLUTIONS

2022
PRODUCT CATALOG



▶ Table of Contents

00 Introduction

About AAEON	00-1
Network Appliances for SDN/NFV	00-2
White Box uCPE Family for SD-WAN	00-3
Network Applications	00-4
Product Lines	00-5
Feature Highlights	00-6

01 Desktop Network Appliances

FWS-2365	Desktop Network Appliance with Intel® Atom® Processor C3000 series	01-1
FWS-2360	Desktop Network Appliance with Intel® Atom® Processor C3000 Series	01-3
FWS-2280	Desktop Network Appliance with Intel® Elkhart Lake Processor	01-5
FWS-2276	Desktop 4 LAN Ports Network Appliance with Intel® Celeron® Processor N3350	01-7
FWS-2275	Desktop 3 LAN Ports Network Appliance with Intel® Celeron® Processor N3350	01-9
FWS-2273	Desktop 6 LAN Ports Network Appliance with Intel® Celeron® N3350 Processor SoC	01-11
FWS-2272	Desktop 4 LAN Ports Network Appliance with Intel® Celeron® N3350 Processor SoC	01-13
FWS-2271	Desktop 6 LAN Ports Network Appliance with Intel® N3350 Processor SoC	01-15
FWS-2277	Desktop Network Appliance with Intel® Celeron® Processor N3350 SoC (formerly Apollo Lake)	01-17



02 Rackmount Network Appliances & Network Interface Modules

FWS-8600	2U Rackmount Network Appliance with Dual 2nd Gen Intel® Xeon® Scalable Processors	02-1
FWS-7541	1U Rackmount Network Appliance with Intel® Xeon® LCC Processor (formerly ICE-Lake-D)	02-3
FWS-7540	1U Rackmount Network Appliance with Intel® Xeon® HCC Processor (formerly ICE-Lake-D)	02-4
FWS-7840	1U Rackmount Network Appliance with 10th Generation Intel® Core™/ Xeon® processor (formerly Comet Lake)	02-5
FWS-7830	1U Rackmount Intel® 8th Generation Platform Network Appliance	02-7
FWS-7831	1U Rackmount Intel® 8th Generation Platform Network Appliance	02-9
FWS-7820	1U Rackmount Network Appliance, Intel® C236 with 3 to 4 Network Interface Modules	02-11
FWS-7821	Intel® C236 1U Rackmount 8 LANs with 1 NIM Slot Network Appliance	02-13
FWS-7360	1U Rackmount 7 LAN Network Appliance with Intel® Atom™ C3758 Processor SoC	02-15

Network Interface Modules

NIM-S13B	Intel® 82580EB (i350-AM4; Optional by request) PCI-Express 1G SFP 8 Ports Module	02-17
NIM-S13D	Intel® 82580EB (i350-AM4; Optional by request) PCI-Express 1G SFP 4 Ports Module	02-17
NIM-S13E	Intel® 82580EB (i350-AM4; Optional by request) PCI-Express 1G Fiber Ethernet 4 Ports Module	02-18
NIM-C13B	Intel® 82580EB (i350-AM4; Optional by request) PCI-Express 1G Copper Ethernet 8 Ports Module	02-18
NIM-C13D	Intel® 82580EB (i350-AM4; Optional by request) PCI-Express 1G Copper Ethernet 4 Ports Module	02-19
NIM-S26B	Intel® XL710 PCI-Express 40G QSFP 2 Ports Module	02-19
NIM-S26C	Intel® XL710 PCI-Express 10G SFP+ 4 Ports Module	02-20
NIM-S26D	Intel® Ethernet Controller XL710-BM1 (Fortville) Quad Port SFP+ 10 GbE LAN Module	02-20

03 Industrial Network Appliances

ICS-6270	DIN Rail 6 LAN Ports Industrial-Grade Network Appliance with Intel® Celeron® N3350 Processor SoC	03-1
ICS-6280	DIN Rail 4 LAN Ports Industrial-Grade Network Appliance with Intel® Elkhart Lake Platform	03-3

04 Industrial Servers

ZEUS-PURO	4U Rackmount Purley Platform Server System, Support Xeon® FPGA CPU	04-1
ARES-WHIO	Intel® whitely Platform Server Board, Support Xeon® Single Ice Lake-SP CPU	04-3

About AAEON

Introduction

As one of the leading manufacturers of advanced hardware platforms for network computing and security solutions, AAEON offers an extensive range of network appliances that support SD-WAN, SDN, NFV, Wireless Gateway, NGFW, Intrusion Detection/Prevention, WAN Optimization, Network Access Control, Load Balancing, Web Content Filtering, Unified Threat Management, and Wireless Network Security. Together, they make up the most versatile and cost-effective networking solutions on the market.

Offering x86-based platforms from Intel® Atom™ all the way to Intel® Xeon processors, and in desktop, 1U and 2U form factors, AAEON's team of experienced network engineers have helped companies around the world deploy reliable network appliances with faster times to market and lower development costs based on state-of-the-art hardware platforms, unmatched service quality, and long-term support.

Established in 1992, AAEON successfully established itself as a leading designer and manufacturer of advanced industrial and embedded computing platforms. AAEON maintains a strong market position providing integrated solutions, hardware, and bespoke services for premier OEM, ODM, and system integrators worldwide. After joining the ASUS group in 2011, AAEON has further strengthened its leadership and continuously pursues innovation and excellence in this industry.

Intel® Network Builders Winner's Circle



<http://networkbuilders.intel.com>

AAEON is honored to be recognized as a Solutions Plus Partner in the Intel® Network Builders Winner's Circle for 2020-2021. This honor recognizes AAEON's efforts and dedication to helping grow the Intel® Network Builders ecosystem with innovative network platforms and solutions utilizing software defined networking (SDN), network function virtualization (NFV) and software defined wide area networks (SD-WAN). AAEON is recognized as a Solutions Plus Partner for its help in accelerating the adoption of advanced IoT and edge networks by leveraging technologies including edge computing, 5G communication, and developing innovative network solutions utilizing the latest Intel architecture including the 2nd Generation Intel® Xeon® Scalable Processors and the Intel® Xeon® D Processor, found in AAEON network solutions such as the FWS-8600.

Network Appliances for SDN/NFV

Introduction

AAEON has continued to innovate its FWS series of network appliances to develop the next generation of easy-to-manage, rapidly deployable appliances designed to power advanced network functions such as Software Defined Networking (SDN) and Network Functions Virtualization (NFV). AAEON is helping to accelerate the adoption of these next generation solutions by leveraging the built-in features of Intel® processor to provide faster and more efficient data transfer and encryption, while reducing the complexity and cost of industrial networks.

The FWS series offers solutions in a range of sizes and configurations, with enterprise-grade 2U rackmount, 1U rackmount and desktop network appliances featuring a broad array of Intel processors including the powerful 2nd Generation Intel® Xeon® Scalable Processors, Intel® Core™ i7/i5/i3, and efficient Intel® Atom™ processors. Designed for scalability and flexible configurations, the FWS family of network appliances offer reliable performance for demanding network applications, and come with various combinations of Ethernet modules including Gigabit Ethernet, SFP Fiber LAN, PCIe expansion slots and LCM with keypad controls.

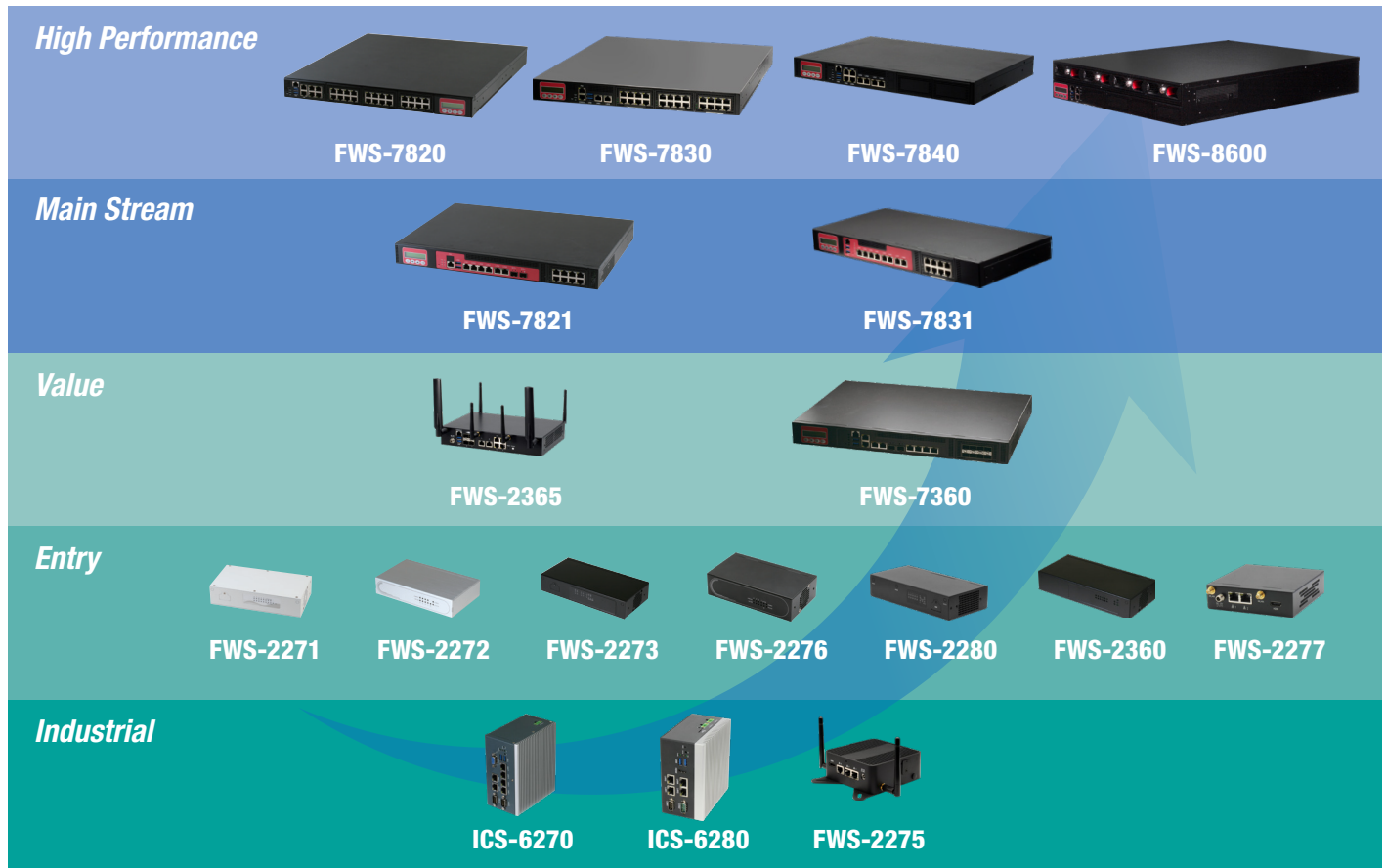

DMS & Collaboration Models

AAEON solutions are backed by world-class service and support designed to reduce time to production and enable you to operate at peak efficiency. With over 25 years of experience designing and automating IT processes, AAEON end-to-end solutions enable your organization to maximize your investment in our network security solutions with professional service that exceeds client expectations. AAEON provides products built for your organization's needs, from customizing existing AAEON products to developing bespoke products. AAEON provides professional level service and collaboration to deploy the best equipment with the highest confidence and quality.

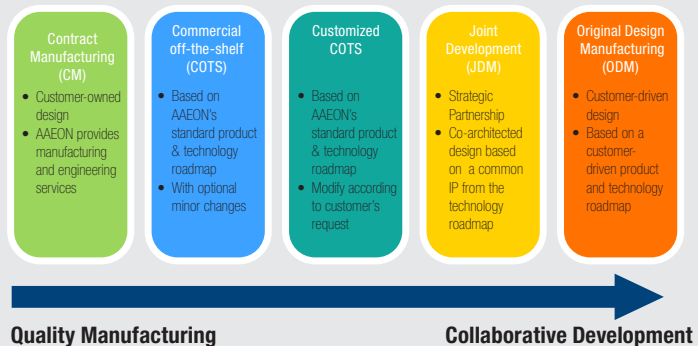

White Box uCPE Family for SD-WAN



Optimized for Virtual Network Functions



AAEON's white box platforms are designed to power any third-party Virtual Network Function (VNF), eliminating the need for proprietary hardware, and accelerating deployment for service providers.

Powering More Applications



To provide agile, reliable, and secure networking, AAEON's white box platforms offer built-in advanced networking technology including performance acceleration (Intel® QAT, AES-NI, VT, SR-IOV, and DPDK), TPM, and Secure Boot, powered with high core-count Intel® x86 processors.

Introduction

In the current environment of companies moving towards connected and virtualized industries, as well as more companies moving towards work from home models, traditional dedicated network appliances are quickly becoming unsustainable. The solution to powering these networks is through leveraging uCPE technology with Software Defined Wide Area Networks (SD-WAN). AAEON brings industry-leading expertise in network appliance and IT edge computing hardware design to offer a broad range of white box platforms ready to power your uCPE, SD-WAN needs.

By leveraging uCPE and SD-WAN technologies, network managers and service providers can reduce the complexity and costs of developing, deploying and maintaining Wide Area Networks. From small desktop systems such as the FWS-2272 and FWS-2273, to rackmount platforms including the FWS-7360, AAEON's family of white box platforms offer the processing performance, wired and wireless connectivity, scalability, and advanced encryption and virtualization technology ensuring agile, reliable and secure operation of your network.

AAEON's white box platforms are designed to power any third-party Virtual Network Function (VNF), eliminating the need for proprietary hardware, and accelerating deployment for service providers. In addition, AAEON white box platforms offer cutting edge security and virtualization technology with built-in support for performance acceleration (Intel® QAT, AES-NI, VT, SR-IOV, and DPDK), TPM, and Secure Boot, all powered by high core-count Intel® x86 processors.



Model	FWS-2272	FWS-2273	FWS-2360	FWS-2365	FWS-7360
Processor	Intel® N3350/ N4200	Intel® N3350/ N4200	Intel® Atom™ C3000	Intel® Atom™ C3000	Intel® Atom™ C3000
Cores	2, 4	2, 4	2, 4, 8	4 ~ 16	8 ~ 16
GbE Ports	4 Copper	4 Copper + 2 SFP	4 Copper + 2 SFP or 6 Copper	6 Copper	5 Copper + NIM
10GbE Ports	—	—	—	2 ~ 4	2

5G Capable MEC Platforms

AAEON Network Appliances offer the power and performance to handle demanding tasks including MEC (Multi-access Edge Computing/Mobile Edge Computing) applications. MEC platforms act as a vital component in the Edge-Cloud ecosystem, combining NFV and Cloud Virtualization to minimize bandwidth requirements and provide an ultra-low latency edge cloud platform, allowing customers to take full advantage of data transfer speeds offered by 5G without needing to increase their communication budgets.

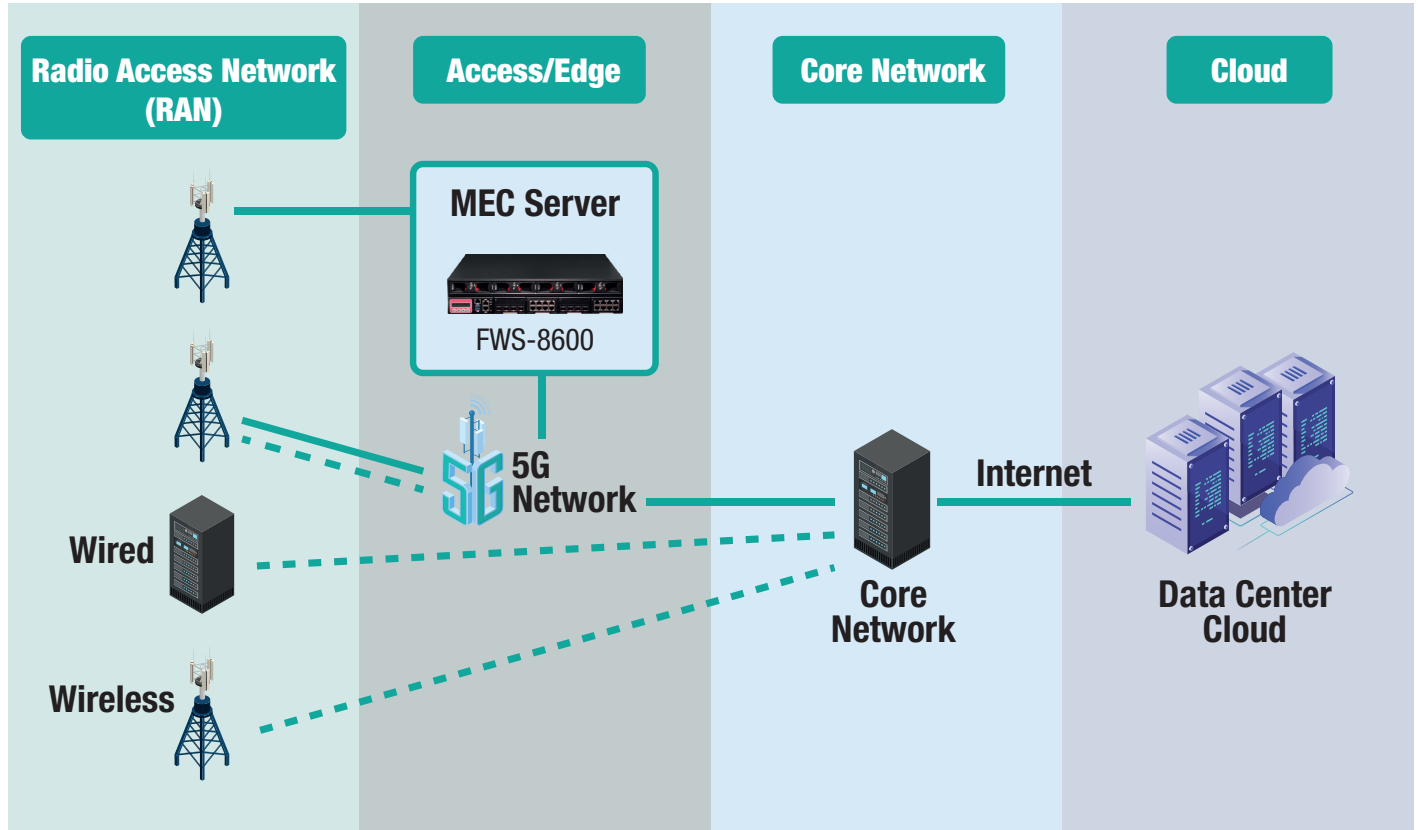

Industrial Cyber Security

With the deployment and expansion of Industry 4.0 technologies like Industrial IoT (IIoT) and Edge Computing, greater numbers of industrial systems are connecting to cloud and SD-WAN networks. This creates a gap in information security, which has been increasingly exploited by cyberattacks and malware. Where Information Technology (IT) systems have traditionally been heavily guarded against such cyber threats, operational technology (OT) systems like PLCs, Industrial Control Systems (ICS) and SCADA, have lagged behind as these systems were previously isolated from broader networks and internet connections. Furthermore, due to the costs already put into deploying OT systems, security budgets for industrial infrastructure are generally tight.

AAEON has developed solutions to help counter the threat of cyberattacks against industrial infrastructure, the compact FWS-2275 and ICS-6270 DIN rail mount network appliance. Both provide a flexible and inexpensive way to add vital network security tools to industrial networks and OT systems. Using AAEON's experience in designing embedded industrial systems, the FWS-2275 and ICS-6270 feature fanless design, rugged metal chassis, and wide operating temperature ranges to ensure long lasting and reliable operation anywhere they're deployed.



ICS-6270

DIN Rail 6 LAN Ports Industrial-Grade Network Appliance with Intel® Celeron® Processor N3350 SoC



FWS-2275

Desktop 3 LAN Ports Network Appliance with Intel® Celeron® Processor N3350



Product Lines



Desktop Network Appliances

AAEON's Desktop Network Appliances support functions such as SD-WAN, vCPE, wired/wireless gateway, network access control, and load balancing in a single, convenient device for simple network security deployment. Its compact size and capability make it an ideal network appliance for small offices and branch offices.

Rackmount Network Appliances

AAEON's Rackmount Network Appliances are designed in both 2U rackmount and 1U rackmount enterprise-grade configurations with a broad selection of processors. Designed for scalability and flexible configurations, the appliances are reliable systems for demanding network applications and come with various combinations of Ethernet modules including GbE and SFP Fiber LAN, PCI-E Bus expansion slots and LCM with keypad control.

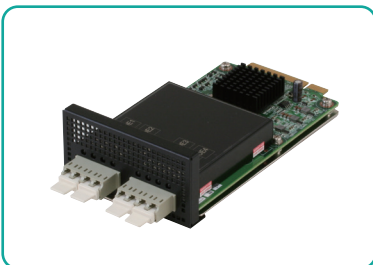

Network Interface Module (NIM)

The dense, feature-rich 1U design network interface modules (NIM) include impressive I/O interfaces. NIMs including GbE, SFP+, and QSFP fiber options allow you to adopt an exceptional array of easily composable configurations and customizations for seamless integration into new and existing infrastructure deployments. This composability ensures the highest degree of flexibility and performance for your environment, dramatically improving server utilization, resource allocation, and ease of management.

Industrial Network Appliances

Combining our expertise in Network Solutions and rugged embedded platforms, AAEON's Industrial Network Appliances are designed to power embedded network computing applications, from Industrial Cyber Security to Mobile NVR. With support for a range of expansion options thanks to mPCIe card slots, these devices can provide wireless connectivity, mobile operation, and power AI and Edge Computing.





Intel® Technologies

AAEON FWS models feature Intel® built-in technologies such as Intel® QuickAssist Technology, Intel® Advanced Encryption Standard Instructions (AES-NI), and Intel® Virtualization Technology (Intel® VT) which can enhance entire network performance, efficiency, and security.



Wireless Connectivity

AAEON FWS models feature mini-card slots for wireless connectivity expansion. In desktop models, this expansion supports functions such as Wi-Fi and support for cellular 3G, 4G/LTE and 5G modules.



Intel® QuickAssist

Intel® QuickAssist Technology speeds up the process of encrypting and compressing secure information, meaning end users can send private information with complete confidence. With the high-powered CPUs used in the AAEON FWS series, this work is isolated from the rest of the system's functions, allowing the devices to continue their other functions without losing speed.



IPMI Remote Management

IPMI is essential in meeting mission-critical business requirements and ensuring that enterprises are able to enjoy uninterrupted, highly available, and highly stable services. IPMI enables administrators to remotely monitor, manage, and maintain systems to provide uninterrupted services and near-zero downtimes.



Data Plane Development Kit (DPDK)

The AAEON FWS series supports Intel® DPDK which can greatly boost packet processing performance and throughput, allowing more time for data plane applications.



Trusted Platform Module (TPM)

The AAEON FWS series supports TPM, which is designed to secure hardware by integrating cryptographic keys into appliances. Pushing security down to the hardware level provides more protection than a software-only solution. Part of latest platform support ANSSI certified TPM.



LAN Bypass Function

Advanced LAN bypass ports protect networks against unexpected in-line system hang. With the aims of AAEON SDK, developers can easily implement the LAN bypass function.



Bluetooth Control Solution

AAEON's network appliances are built for maximum scalability and integration, and they incorporate 3E (3- Easy) core tenets: Connectivity, Maintenance and Control. Our systems feature a Bluetooth interface, eliminating the need for external console cables and/or USB drives, and they are easily operated from tablets, mobile phones, or other Bluetooth devices.

*Note: Only supports Android OS



Swappable Design for Varied Configurations



Redundant Power Supplies



Software Programmable Button



Hot Swappable Fans



LCM & Keypad

01

► Desktop Network Appliances



01

FWS-2365

Desktop Network Appliance with Intel® Atom® Processor C3000 series

Front View

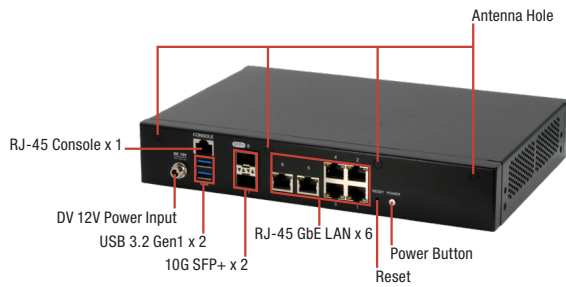

Rear View

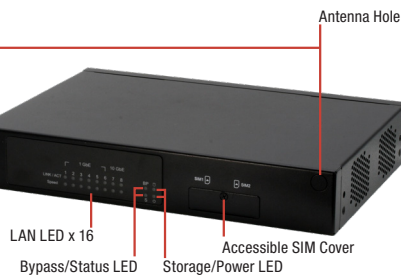

With Antennas installed



(Antennas: Optional Accessories)

Features

- Intel® Atom® Processor C3000 series
- 10/100/1000Base-TX Ethernet x 6
- Supports 1 pair bypass (LAN 3 ~ 4)
- Up to 4 x 10G SFP+ Port (C3558 only supports 2 port)
- DDR4 SODIMM socket x 2
- SATA III Port x 2
- On board 16GB eMMC, up to 128GB
- Mini-card slot x 1 (Half-size, PCIe), Mini-card slot x 1 (Full-size, PCIe + USB2.0) with SIM slot
- M.2 B key 3052 x 1 (USB3.0) with SIM slot
- USB3.0 TypeA Port x 2 (1 Port only support USB2.0 signal)



Internal/ Expansion Interface	
PCIe Slot	—
Mini-PCIe Slot	Mini-card slot x 1 (Half-size, PCIe) Mini-card slot x 1 (Full-size, PCIe + USB2.0) with SIM slot M.2 B key 3052 x 1 (USB3.0) with SIM slot
Keyboard and Mouse	Reserved pin-header
USB	USB 3.0 x 2 (1 Port only support USB2.0 signal)
Miscellaneous	
RTC	Internal RTC
Watchdog Timer	1~255 steps by software programmable
Software Button	GPIO programmable push button x 1
TPM	TPM v2.0 9665
GPIO	4 bits input/ 4 bits output
Fan	System Fan x 1
MTBF (Hours)	TBD
Color	Black
Environmental Parameters and Dimension	
Power Requirement	12V DC Power in connector 4 Cores: 40W Power Adapter 8 Cores and above: 60W Power Adapter
Operating Temperature	32°F ~ 104°F (0°C ~ 40°C)
Storage Temperature	-4°F ~ 140°F (-20°C ~ 60°C)
Operating Humidity	10%~80% relative humidity, non-condensing
Storage Humidity	10%~80% @40°C; non-condensing
Vibration	0.5 Grms/ 5 ~ 500Hz / operation (2.5" HDD) 1.5 Grms/ 5 ~ 500Hz / non operation
Shock	10 G peak acceleration (11 m sec. duration), operation 20 G peak acceleration (11 m sec. duration), non operation
Dimension (W X D X H)	260mm x 178mm x 44mm
I/O	
Front Panel	Power LED x 1 Status LED x 1 Storage Active LED x 1 Bypass LED x 1 Ethernet LED x 20 Antenna Hole x 2 Accessible SIM slot x 2
Rear Panel	USB 3.0 Port x 2 RJ-45 Port x 6 SFP+ Port x 2 RJ-45 Console x 1 12V DC Power Input x 1 Software Reset Button x 1 Power Button x 1 Antenna Hole x 4

Specifications

System	
Form Factor	Desktop Network Appliance
Processor	Intel® Atom® Processor C3000 series (4~16 cores)
Chipset	SoC
System Memory	DDR4 SODIMM socket x 2
Network	
Ethernet	1GbE RJ-45 x 6 (2 ports co-lay SFP) 10G SFP+ x 4 (4 cores only support 2 port)
Bypass	Supports 1 pairs on LAN 3-4
Display	
Graphic Controller	—
Connector	—
Storage	
HDD	SATA III port x 2, 2.5" HDD/SSD up to 2
CF/CFast/MSATA	On board 16GB eMMC, up to 128GB optional mSATA slot x 1 (co-lay with M.2 slot)

Note: All specifications are subject to change without notice.

Dimension

Unit: mm

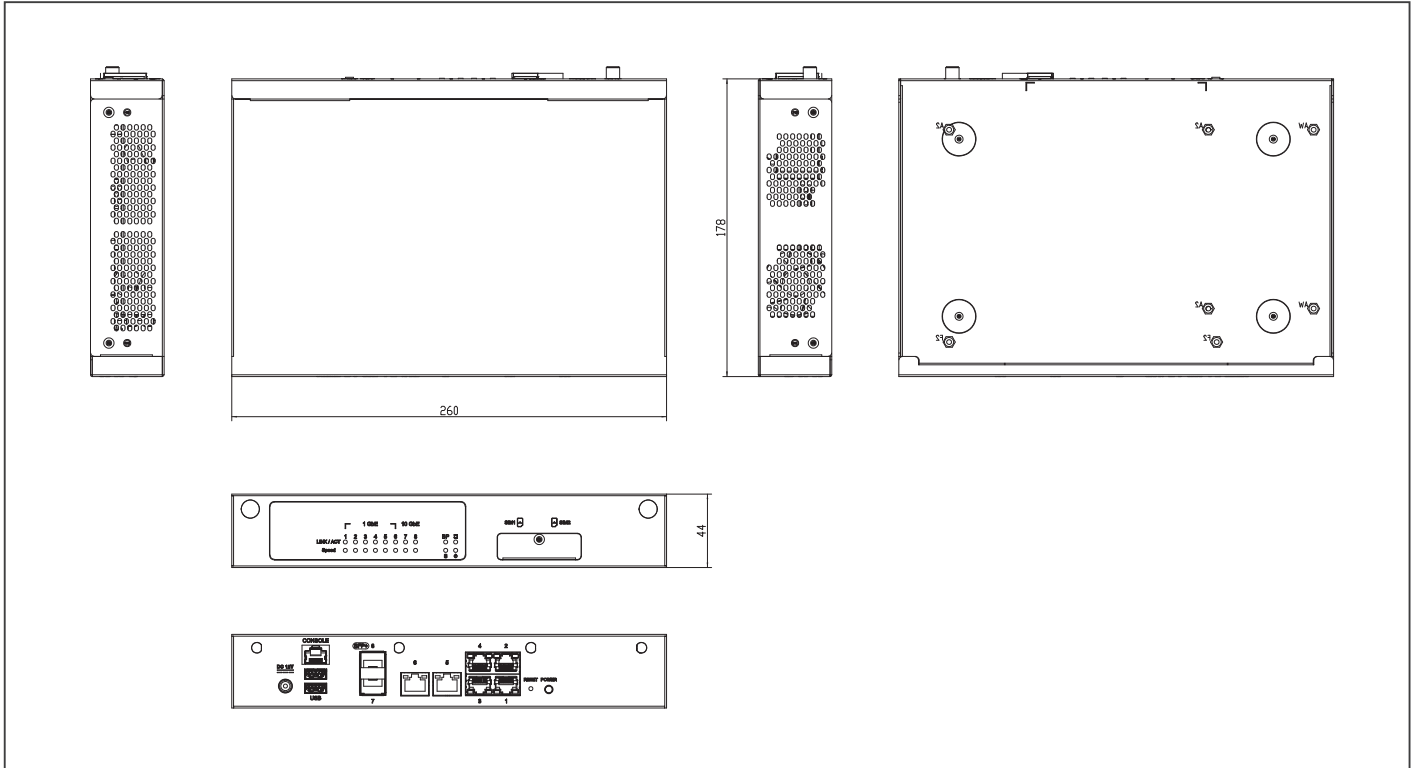

Ordering Information

Part Number	CPU	RAM	Bypass	Expansion Slot	Storage	LAN	USB	Console	System Fan	TPM	Display	Mounting	Power
FWS-2365-E8-A10-00	Intel® Atom® C3558	260-pin DDR4 SODIMM socket x 2	1 pairs (LAN3-4)	Mini-card slot x 1 (Half-size, PCIe) Mini-card slot x 1 (Full-size, PCIe + USB2.0) with SIM slot M.2 B key 3052 x 1 (USB3.0) with SIM slot	On board 16GB eMMC SATA III Port x 2 2.5" HDD Bay x 1	6 x 1Gb RJ-45 2 x 10Gb SFP+	USB3.0 TypeA Port x 2 (1 Port only support USB2.0 signal)	RJ-45 x 1	1 x System Fan	TPM v2.0 9665	—	Desktop	DC

Packing List

- SATA Cable x 1
- SATA Power Cable x 1
- 40W Power Adapter x 1 (C3558 SKU)
- FWS-2365

Optional Accessories

- **1700091805**
Console Cable
- **1702031802**
Power Cord, 3P-250V/10A, 180D, 1.8M, USA, YP12/YC-12
- **1702031803**
Power Cord, 3P-250V/10A, 180D, 1.8M, VDE, YP22/YP12
- **170203180B**
Power Cord, 3P-250V/10A, 180D, 1.8M, China, YP-03/YC-12
- **170203180E**
Power Cord, 3P-125V/7A, 1.8M, PSE, YP12/YC-12
- **9761220030**
1U Rackmount Ear Bracket kit

FWS-2360

Desktop Network Appliance with Intel® Atom® Processor C3000 Series

Front View

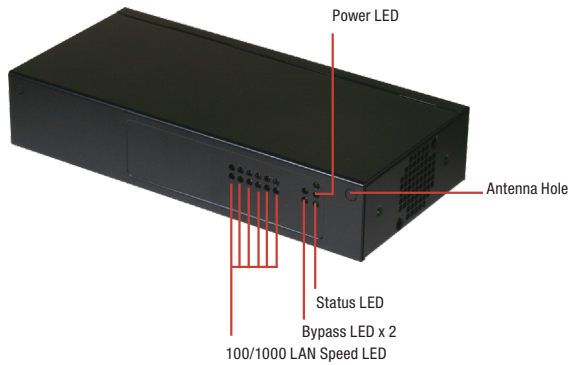

Rear View

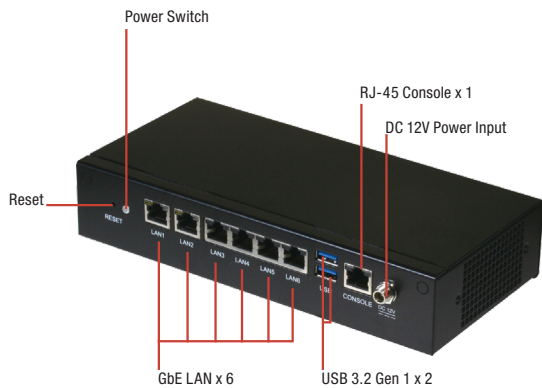

Features

- Desktop Network Appliance
- Intel® Atom® C3000 Series Processor Supports Dual and Quad Core
- DDR4 SODIMM/ ECC DIMM (Dual Core 1 Slot Quad Core 2 Slot)
- 4 Copper(88E1543) + 2 Copper(I211), optional 4 Copper(88E1543) + 2 Fiber(I210)
- 2 Pairs Bypass Support
- Mini PCIe with SIM Slot Support
- Internal 2.5" SATA HDD Bay x 1 (Optional)
- eMMC Support up to 16GB
- RJ-45 Console x 1
- USB 3.2 Gen 1 x 2 (Internal USB 2.0 x 1)



Internal/ Expansion Interface

PCIe Slot	—
Mini-PCIe Slot	Mini-Card socket (full-size) x 2 (1 with SIM socket)
Keyboard and Mouse	Reserved pin-header
USB	Dual Core: USB 3.2 Gen 1 x 1 + USB2.0 x 1

Miscellaneous

RTC	Internal RTC
Watchdog Timer	1~255 steps by software programmable
Software Button	—
TPM	(TPM v1.2 9660/TPM2.0 9665 Optional)
GPIO	(4 bits input, 4bits output optional)
Fan	System fan x 1
MTBF (Hours)	149683 Hours
Color	Black

Environmental Parameters and Dimension

Power Requirement	12V DC Power in connector
Operating Temperature	32°F ~ 104°F (0°C ~ 40°C)
Storage Temperature	-4°F ~ 140°F (-20°C ~ 60°C)
Operating Humidity	10%~80% relative humidity, non-condensing
Storage Humidity	10%~80% @40°C; non-condensing
Vibration	0.5 Grms/ 5 ~ 500Hz / operation (2.5" HDD) 1.5 Grms/ 5 ~ 500Hz / non operation
Shock	10 G peak acceleration (11 m sec. duration), operation 20 G peak acceleration (11 m sec. duration), non operation
Dimension (W X D X H)	8.66" x 4.13" x 1.73" (220mm x 105mm x 44mm)

I/O

Front Panel	Power LED x 1, Status LED x 1, Storage Active LED x 1, Bypass LED x 2, LAN LED x 12, (Antenna Hole x 2 Optional)
Rear Panel	USB 3.2 Gen 1 Port x 2, RJ-45 Port x 6 (Optional RJ-45 x 4 + SFP x 2) RJ-45 Console x 1, 12V DC Power Input x 1, Software Reset Button x 1, Power Button x 1, (Antenna Hole x 2 Optional)

Specifications

System	
Form Factor	Desktop Network Appliance
Processor	Intel® Atom™ Processor C3000 Series supports dual and quad core
Chipset	SoC
System Memory	DDR4 SODIMM ECC DIMM (Dual core 1 slot Quad core 2 Slot) Up to 32GB
Network	
Ethernet	Intel® X553 (Marvell 88E1543) RJ45 x 4 Default Intel® i211 GbE x 2 (Intel® i210 SFP x 2 Optional)
Bypass	Supports up to 2 pairs bypass function
Display	
Graphic Controller	—
Connector	—
Storage	
HDD	2.5" HDD Bay x 1
CF/CFast/MSATA	SATA 6.0 Gb/s port x 1(Onboard eMMC up to 16GB optional)

Dimension

Unit: mm

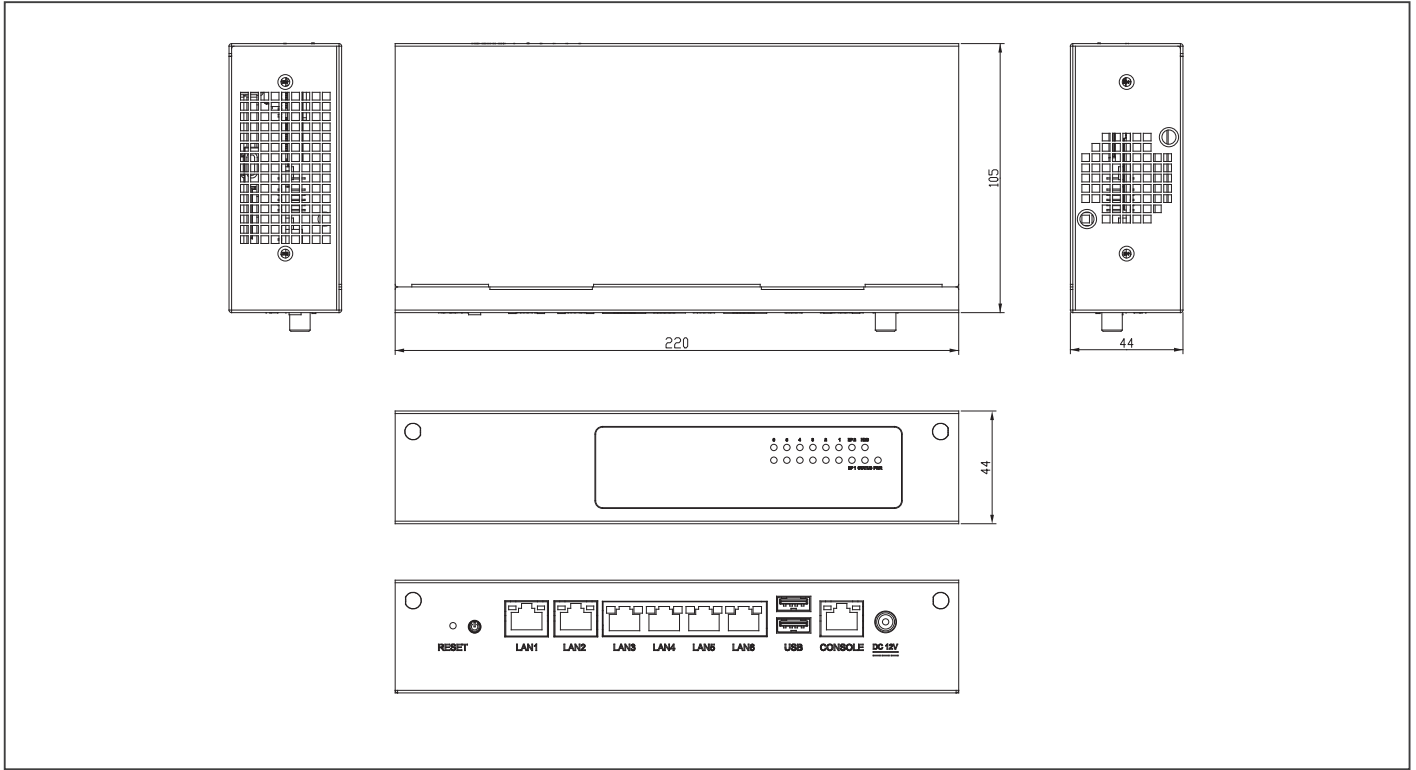

Ordering Information

Part Number	CPU	RAM	Bypass	Mini-Card Slot	Storage	LAN	USB	Console	System Fan	TPM	Display	Mounting	Power
FWS-2360E6-A10-00	Intel® Atom® C3558	260-pin DDR4 SODIMM/ ECC socket x 2	2 pairs	Full Size x 2 (PCIe + USB), 1 with SIM socket	2.5" HDD Bay x 1	6 Intel® X553 (Marvell 88E1543) RJ45 x 4 Default Intel® i211 GbE x 2	USB 3.2 Gen 1 x 2	RJ-45 console x 1	1	—	—	Desktop	DC

Packing List

- Power Adapter
- SATA Cable
- SATA Power Cable
- FWS-2360

Optional Accessories

- **1702031803**
Power Cord, 3P-250V/10A, 180D, 1.8M, VDE, YP12/YC-12
- **1702031802**
Power Cord, 3P-250V/10A, 180D, 1.8M, USA, YP12/YC-12
- **170203180B**
Power Cord, 3P-250V/10A, 180D, 1.8M, China, YP-03/YC-12
- **170203180E**
Power Cord, 3P-125V/7A, 1.8M, PSE, YP12/YC-12
- **1700091805**
Console Cable

FWS-2280

Desktop Network Appliance with Intel® Elkhart Lake Processor

Front View

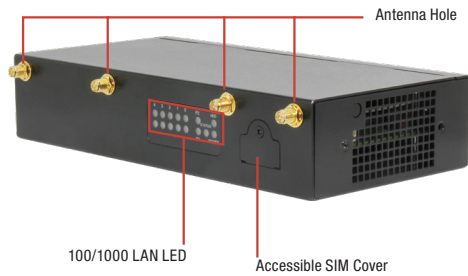

Rear View

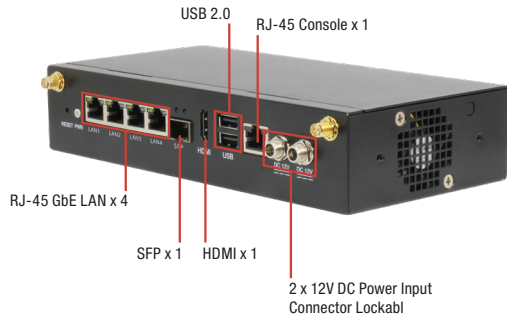

With Antennas installed



(Antennas: Optional Accessories)

Features

- Intel® Elkhart lake SoC Processor, 2~4 cores
- 260-pin DDR4 3200MHz SODIMM x 1, Up to 32GB
- Intel® i211 GbE x 4, Intel® i210 SFP x 1
- Mini-Card full size (with SIM socket) x 1
- Mini-Card half size slot x 1
- M.2 B key 3052 slot (with SIM socket) x 1 (Optional)
- Redundant power support



Internal/ Expansion Interface

PCIe Slot	—
Mini-PCIe Slot	Mini Card Socket (PCIe + USB 2.0, full size) with SIM x1 Mini Card Socket (PCIe, half size) x1 M.2 B key 3052 (USB 3.0, full size) with SIM x1(Optional)
Keyboard and Mouse	—
USB	USB 2.0 Type A x 2

Miscellaneous

RTC	Internal RTC
Watchdog Timer	1~255 steps by software programmable
Software Button	GPIO Programmable push button x 1
TPM	(TPM SLB9670 VQ2.0 FW7.85 Optional)
GPIO	(4 bits input, 4bits output optional)
Fan	Smart fan x 1
MTBF (Hours)	TBD
Color	Black

Environmental Parameters and Dimension

Power Requirement	2 x 12V DC Power Input Connector Lockable, 40W power adapter
Operating Temperature	32°F ~ 104°F (0°C ~ 40°C)
Storage Temperature	-4°F ~ 140°F (-20°C ~ 60°C)
Operating Humidity	10%~80% relative humidity, non-condensing
Storage Humidity	10%~80% @40°C; non-condensing
Vibration	0.5 Grms/ 5 ~ 500Hz / operation (mSATA) 1.5 Grms/ 5 ~ 500Hz / non-operation
Shock	10 G peak acceleration (11 m sec. duration), operation 20 G peak acceleration (11 m sec. duration), non-operation
Dimension (W X D X H)	8.27" x 4.09" x 1.73" (210mm x 105mm x 44mm)

I/O

Front Panel	3 x LEDs (Power, Status, Storage) 1 x Micro-SIM 2 x Antenna Hole
Rear Panel	2 x DC Power Input Connector Lockable 1 x Power Button 2 x USB2.0 Ports 4 x 1GbE RJ45 Ports, 1 SFP 1 x RJ-45 console 1 x Reset Button 3 x Antenna Hole

Specifications

System	
Form Factor	Desktop Network Appliance
Processor	Intel Elkhart lake SoC Processor 2~4 cores
Chipset	SoC
System Memory	260-pin DDR4 SO-DIMM x 1, 3200MHz
Network	
Ethernet	Intel® i211, Gigabit Ethernet x 4 Intel® i210, SFP x 1
Bypass	—
Display	
Graphic Controller	Intel® UHD Graphics
Connector	HDMI x 1
Storage	
HDD	—
CF/CFast/MSATA	mSATA slot x 1 SATA III port x 1

Dimension

Unit: mm

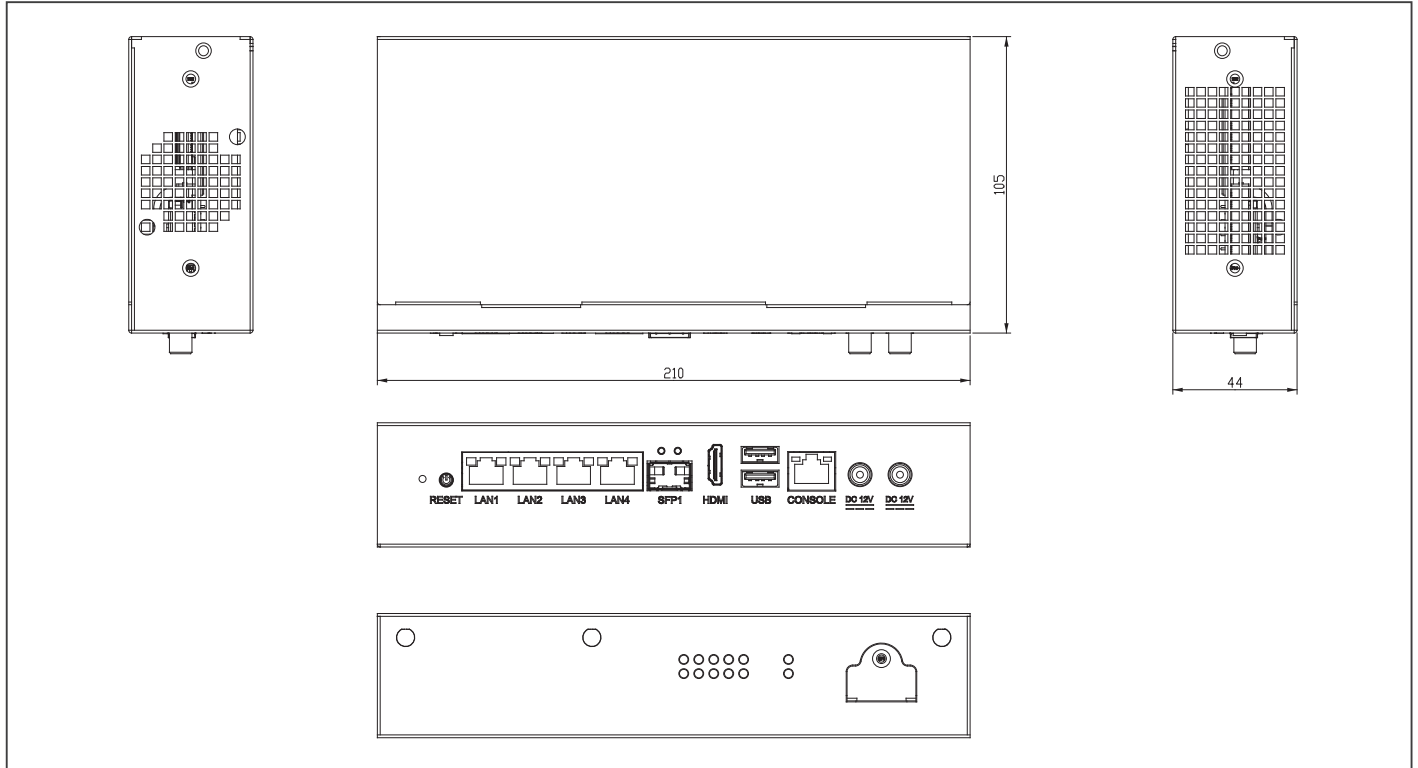

Ordering Information

Part Number	CPU	RAM	Bypass	Mini-Card Slot	Storage	LAN	USB	Console	System Fan	TPM	Display	Mounting	Power
FWS-2280-E5-A10-000	Intel® Elkhart Lake J6412	DDR4 3200 SODIMM socket x 1	—	Mini Card Socket (PCIe +USB) x1(Full size) Mini Card Socket (PCIe) x1 (Half size)	SATA III Port x 1	4 x 1Gb RJ-45 1 x 1Gb SFP	USB2.0 TypeA	RJ-45 x 1	Smart fan x 1	—	1 x HDMI	Desktop	DC 12V Power adapter x1

Packing List

- Power Adapter x 1
- FWS-2280
- 2.5" SSD Bay x 1

Optional Accessories

- **1700091805**
Console Cable
- **1702031802**
Power Cord, 3P-250V/10A, 180D, 1.8M, USA, YP12/YC-12
- **1702031803**
Power Cord, 3P-250V/10A, 180D, 1.8M, VDE, YP22/YP12
- **170203180B**
Power Cord, 3P-250V/10A, 180D, 1.8M, China, YP-03/YC-12
- **170203180E**
Power Cord, 3P-125V/7A, 1.8M, PSE, YP12/YC-12

FWS-2276

Desktop 4 LAN Ports Network Appliance with Intel® Celeron® Processor N3350

Front View

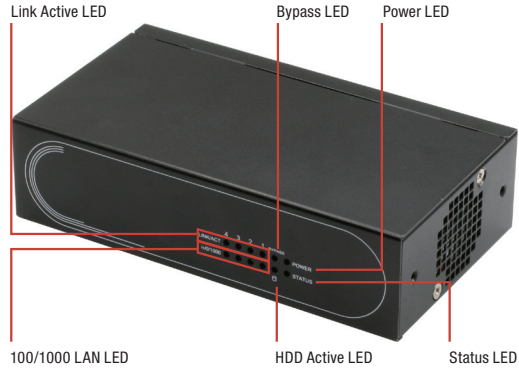

Rear View

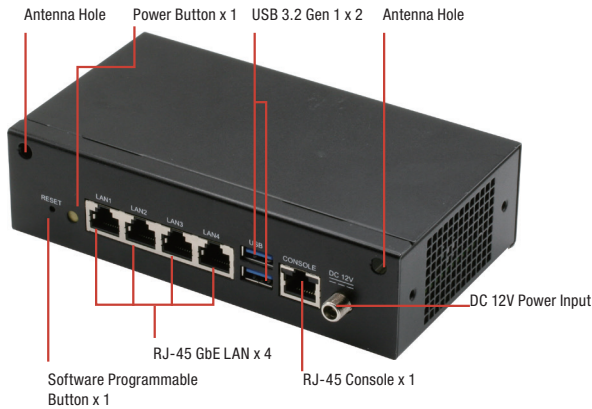

Specifications

System	
Form Factor	Desktop Network Appliance
Processor	Intel® Celeron® Processor N3350 SoC
Chipset	SoC
System Memory	Onboard LPDDR4 2GB memory
Network	
Ethernet	Intel® i211 GbE x 4
Bypass	1 pair bypass function
Display	
Graphic Controller	Intel® HD graphics integrated
Connector	—
Storage	
HDD	2.5" HDD Bay x 1
CF/CFast/MSATA	Onboard 8GB eMMC, SATA 6.0 Gb/s port x 1

Features

- Desktop Network Appliance
- Intel® Celeron® Processor N3350
- Onboard LPDDR4 2 GB Memory
- Gigabit Ethernet x 4 (Intel® i211)
- 1 Pair Bypass
- Internal 2.5" SATA HDD Bay x 1
- Onboard 8 GB eMMC
- RJ-45 Console x 1
- USB 3.2 Gen 1 x 2



Internal/ Expansion Interface

PCIe Slot	—
Mini-PCIe Slot	—
Keyboard and Mouse	—
USB	USB 3.2 Gen 1 x 2

Miscellaneous

RTC	Internal RTC
Watchdog Timer	1~255 steps by software programmable
Software Button	—
TPM	(TPM v1.2 9660/TPM2.0 9665 Optional)
GPIO	4 bits input, 4bits output optional
Fan	1
MTBF (Hours)	166,000
Color	Black

Environmental Parameters and Dimension

Power Requirement	12V DC Power
Operating Temperature	32°F ~ 104°F (0°C ~ 40°C)
Storage Temperature	-4°F ~ 140°F (-20°C ~ 60°C)
Operating Humidity	10%~80% relative humidity, non-condensing
Storage Humidity	10%~80% @40°C; non-condensing
Vibration	0.5 Grms/ 5 ~ 500Hz / operation (2.5" HDD) 1.5 Grms/ 5 ~ 500Hz / non operation
Shock	10 G peak acceleration (11 m sec. duration), operation 20 G peak acceleration (11 m sec. duration), non operation
Dimension (W X D X H)	6.5" x 3.62" x 1.57" (165mm x 92mm x 40mm)

I/O

Front Panel	Power LED x 1 Status LED x 1 HDD Active LED x 1 Bypass LED x 1 LAN LEDs x 8
Rear Panel	USB 3.2 Gen 1 Port x 2 RJ-45 Port x 4 RJ-45 Console x 1 12V DC Power Input x 1 Software Programmable Button x 1 Antenna Hole x 2 Optional

Dimension

Unit: mm

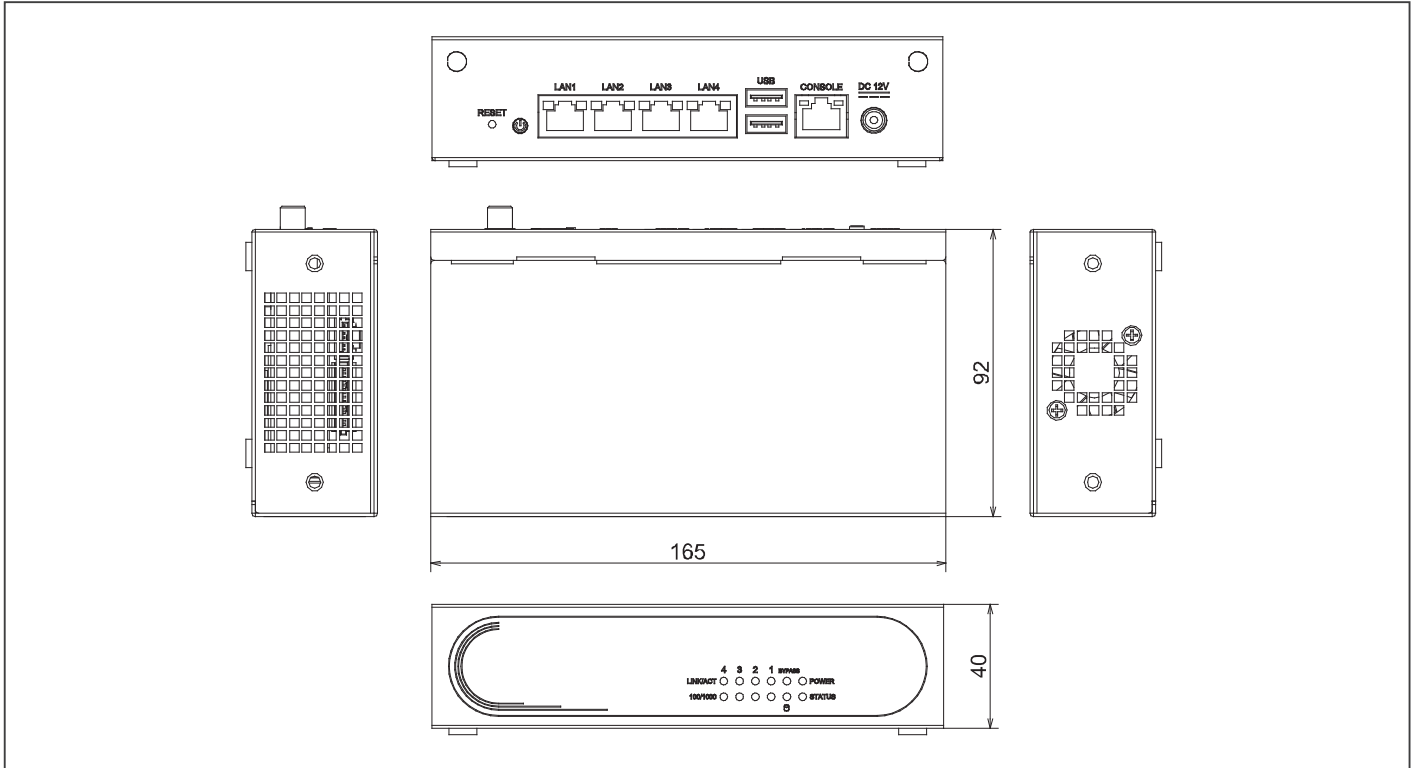

Ordering Information

Part Number	CPU	Memory	Mini-Card Slot	Storage	Display	LAN	USB	Console	Bypass	TPM	Fan	Mounting	Power	Note
FWS-2276E4-A10-A10-000	Intel® Celeron® N3350	Onboard LPDDR4 2GB memory	—	2.5" HDD Bay x 1 ,Onboard 8GB eMMC	—	Intel® i211 GbE x 4	USB 3.2 Gen 1 x 2	RJ-45 console x 1	1 pairs	—	1	Desktop	DC	* Please contact AAEON for other optional specifications.

Packing List

- SATA Cable x 1
- SATA Power Cable x 1
- Power Adapter
- FWS-2276

Optional Accessories

- **1700091805**
Console Cable
- **1702031802**
Power Cord, 3P-250V/10A, 180D, 1.8M, USA, YP22/YP12
- **1702031803**
Power Cord, 3P-250V/10A, 180D, 1.8M, VDE, YP22/YP12
- **170203180B**
Power Cord, 3P-250V/10A, 180D, 1.8M, China, YP-03/YC-12
- **170203180E**
Power Cord, 3P-250V/10A, 180D, 1.8M, PSE, YP12/YC-12

FWS-2275

Desktop 3 LAN Ports Network Appliance with Intel® Celeron® Processor N3350

Front View

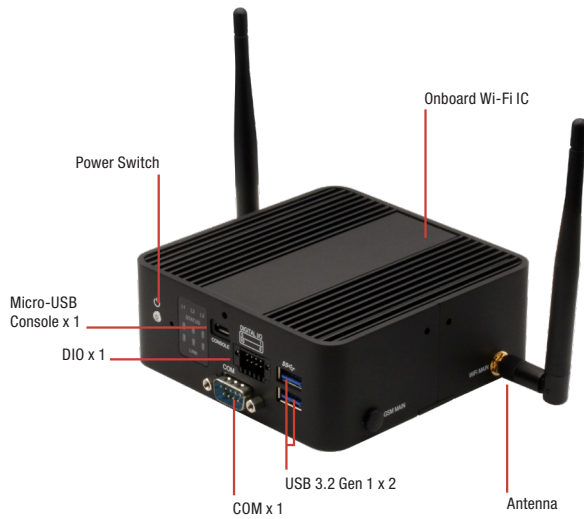

Rear View



Features

- Desktop Network Appliance
- Intel® Celeron® Processor N3350 SoC
- Onboard eMMC 16GB (Optional up to 32GB)
- Onboard LPDDR4, 2GB
- Intel® i211 GbE x 3
- 1 x Mini-Card Full Size Slot with SIM Socket
- Onboard WiFi 802.11 b/g/n 2x2, BT4.1
- HDMI Connector (Optional)
- TPM Supported (Optional)



Internal/ Expansion Interface

PCIe Slot	—
Mini-PCIe Slot	Mini-Card Full Size Slot with SIM Socket x 1 (USB 2.0; PCIe co-lay with LAN 3)
Keyboard and Mouse	—
USB	USB 3.2 Gen 1 x 2
Miscellaneous	
RTC	Internal RTC
Watchdog Timer	1~255 steps by software programmable
Software Button	GPIO Programmable push button x 1
TPM	(TPM2.0 9665 Optional)
GPIO	4 bits input, 4bits output
Fan	—
MTBF (Hours)	550,521 Hours
Color	Black

Environmental Parameters and Dimension

Power Requirement	9~24 V DC Power
Operating Temperature	32°F ~ 122°F (0°C ~ 50°C)
Storage Temperature	-4°F ~ 140°F (-20°C ~ 60°C)
Operating Humidity	10%~80% relative humidity, non-condensing
Storage Humidity	10%~80% @40°C; non-condensing
Vibration	0.5 Grms/ 5 ~ 500Hz / operation 1.5 Grms/ 5 ~ 500Hz / non operation
Shock	10 G peak acceleration (11 m sec. duration), operation 20 G peak acceleration (11 m sec. duration), non operation
Dimension (W X D X H)	4.53" x 4.53" x 1.73" (115mm x 115mm x 44mm)

I/O	
Front Panel	USB 3.2 Gen 1 Ports x 2 LED's (3 x TOP Row, 2 x Bottom Row)x 6 Power Button with LED integrated x 1 Micro-USB Console Port x 1 RS-232/422/485 x 1 GPIO 8 bits, 4-bits input, 4-bits output Reset button x 1
Rear Panel	1GbE RJ45 Ports x 3 Power Input connector, lockable x 1
Left I/O	SIM Slot x 1 + Micro-SD Slot with Cover x 1 WiFi Antenna Connector x 1 LTE Antenna Connector
Right I/O	WiFi Antenna Connector x 1 LTE Antenna Connector

Specifications

System	
Form Factor	Desktop Network Appliance
Processor	Intel® Celeron® Processor N3350 SoC
Chipset	SoC
System Memory	Onboard LPDDR4, 2GB
Network	
Ethernet	Intel® i211 GbE x 3
Bypass	—
Display	
Graphic Controller	Intel® HD graphics integrated
Connector	(HDMI Connector x1 Optional)
Storage	
HDD	—
CF/CFast/mSATA	Onboard eMMC 16GB (Optional up to 32GB) SATA III Port x 1 for SATA DOM Micro SD card Reader x1

Dimension

Unit: mm

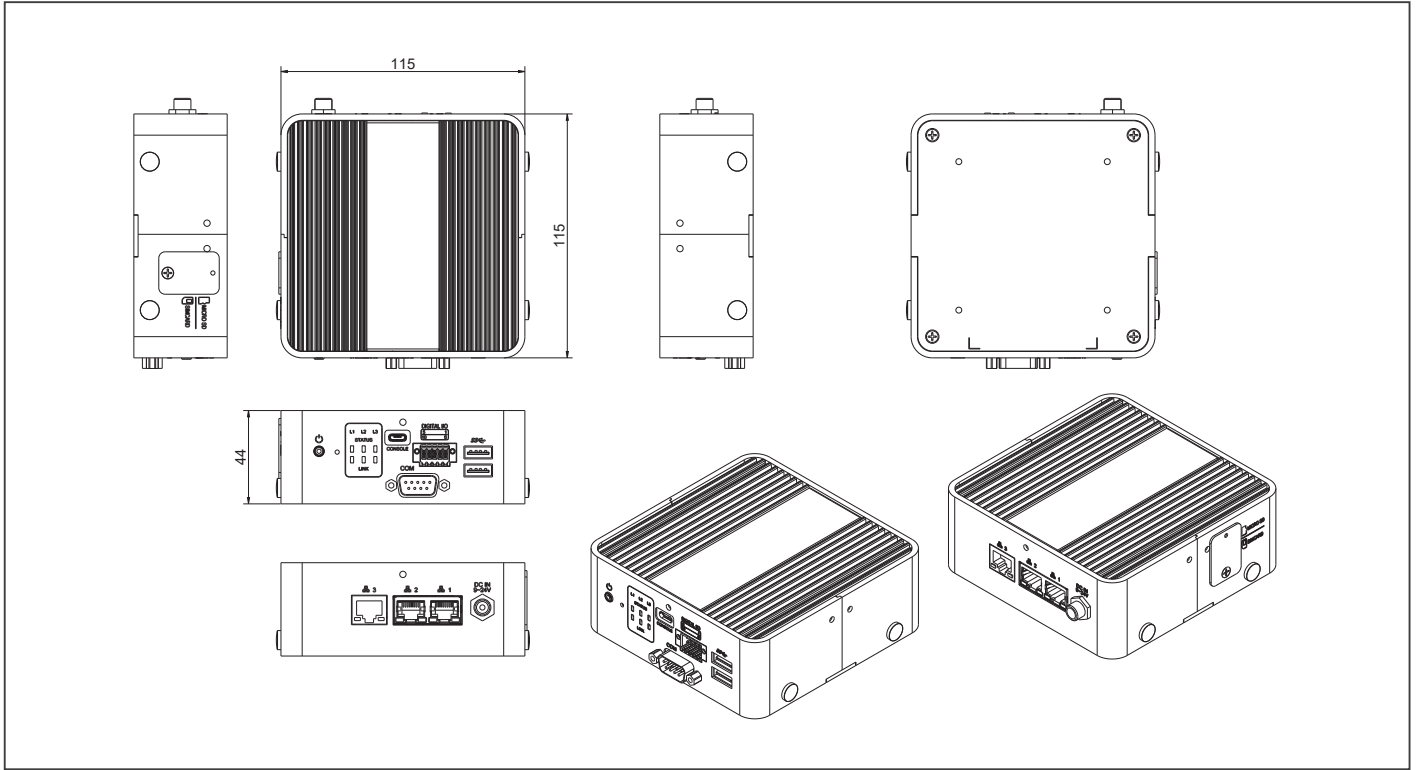

Ordering Information

Part Number	CPU	Memory	Mini-Card Slot	Storage	Display	LAN	USB	Console	Bypass	TPM	Fan	Mounting	Power	Note
FWS-2275E3-A10-00	Intel® Celeron® N3350	Onboard LPDDR4 2GB memory	Mini-Card Full Size Slot with SIM Socket x 1 (USB 2.0)	16GB eMMC SATA III Port x 1 for SATA DOM Micro SD card Reader x 1	—	Intel® i211 x 3	USB 3.2 Gen 1 x 2	Micro USB console x 1	—	—	—	Desktop	DC 12V, 40W Power Adapter x1	* Please contact AAEON for other optional specifications.

Packing List

- Antenna x 2
- Power Adapter x 1
- VESA mount x 1
- FWS-2275

Optional Accessories

- **1702031802**
Power Cord, 3P-250V/10A, 180D, 1.8M, USA, YP22/YP12
- **1702031803**
Power Cord, 3P-250V/10A, 180D, 1.8M, VDE, YP22/YP12
- **170203180B**
Power Cord, 3P-250V/10A, 180D, 1.8M, China, YP-03/YC-12
- **170203180E**
Power Cord, 3P-250V/10A, 180D, 1.8M, PSE, YP12/YC-12

FWS-2273

Desktop 6 LAN Ports Network Appliance with Intel® Celeron® N3350 Processor SoC

Front View

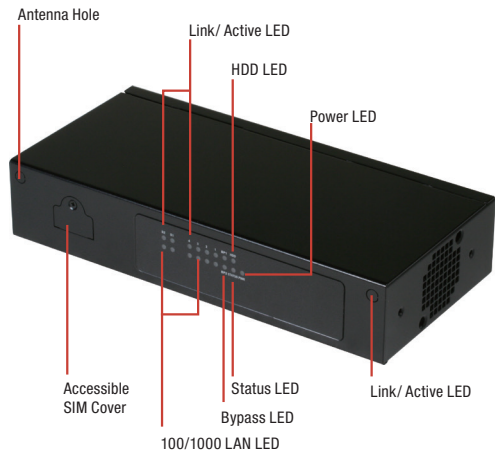

Rear View

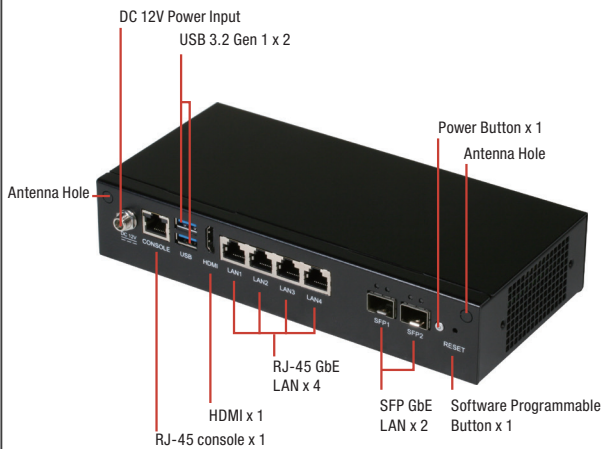

Specifications

System	
Form Factor	Desktop Network Appliance
Processor	Intel® Celeron® N3350 Processor
Chipset	Intel® Celeron® N3350 Processor
System Memory	204-pin DDR3L SODIMM x 1, up to 8GB
Network	
Ethernet	Intel® i211, Gigabit Ethernet x 4 Intel® i210, SFP x 2
Bypass	Supports up to 2 pairs bypass function
Display	
Graphic Controller	Intel® HD Graphics 505 Intergrated
Connector	HDMI x 1
Storage	
HDD	2.5" HDD Bay x 1
CF/CFast/MSATA	CompactFlash™ socket x 1 (Co-lay for BOM Optional CFast™ socket x 1) SATA 6.0 Gb/s port x 1

Features

- Intel® Celeron® N3350 Processor SoC
- 10/100/1000Base-TX x 6 (4 x RJ-45, 2 x SFP connector)
- Supports up to 2 Pair Bypass
- CF Socket x 1, SATA 6.0 Gb/s Port x 1 for 2.5" HDD/SSD
- Mini-Card Slot (with SIM Socket) x 2
- RJ-45 Console x 1, USB 3.2 Gen 1 x 2



Internal/ Expansion Interface

PCIe Slot	—
Mini-PCIe Slot	Mini-Card socket (full-size) with SIM socket x 2
Keyboard and Mouse	Reserved pin-header
USB	USB 3.2 Gen 1 x 2

Miscellaneous

RTC	Internal RTC
Watchdog Timer	1~255 steps by software programmable
Software Button	—
TPM	(TPM v1.2 9660/TPM2.0 9665 Optional)
GPIO	Reserved internal pin-header 8-bit Digital I/O interface (4-in /4-out)
Fan	Fanless, reserved pin-header for system fan
MTBF (Hours)	109,725
Color	Black

Environmental Parameters and Dimension

Power Requirement	12V DC Power in connector
Operating Temperature	32°F ~ 104°F (0°C ~ 40°C)
Storage Temperature	-4°F ~ 140°F (-20°C ~ 60°C)
Operating Humidity	10%~80% relative humidity, non-condensing
Storage Humidity	10%~80% @40°C; non-condensing
Vibration	0.5 Grms/ 5 ~ 500Hz / operation (2.5" HDD) 1.5 Grms/ 5 ~ 500Hz / non operation
Shock	10 G peak acceleration (11 m sec. duration), operation 20 G peak acceleration (11 m sec. duration), non operation
Dimension (W x D x H)	8.66" x 4.13" x 1.73" (220mm x 105mm x 44mm)

I/O

Front Panel	Power LED x 1 Status LED x 1 Storage Active LED x 1 Bypass LED x 2 LAN LED x 12
Rear Panel	USB 3.2 Gen 1 Port x 2 RJ-45 Port x 4 SFP x 2 RJ-45 Console x 1 12V DC Power Input x 1 Software Reset Button x 1 Power Button x 1 HDMI x 1 Antenna Hole x 2

Dimension

Unit: mm

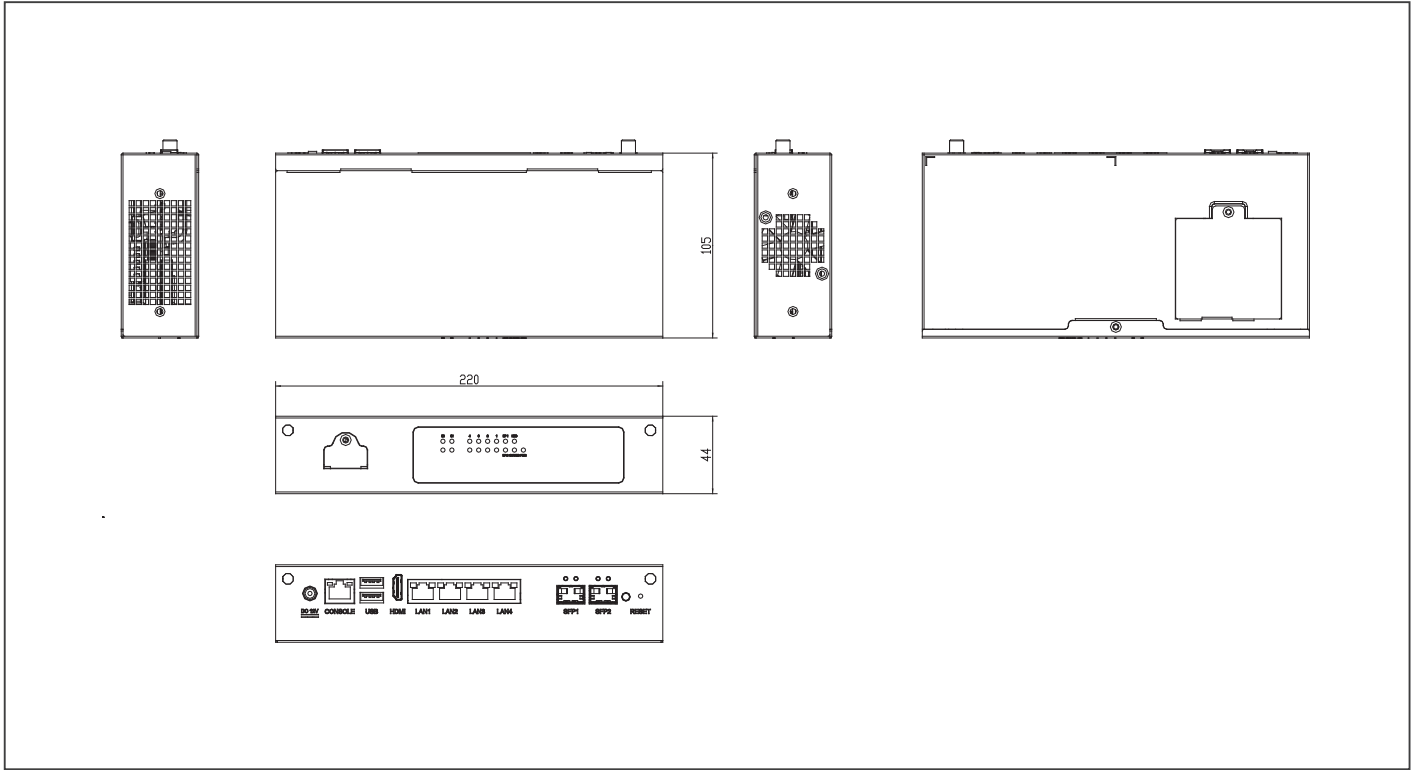

Ordering Information

Part Number	CPU	RAM	Bypass	Mini-Card Slot	Storage	LAN	USB	Console	System Fan	TPM	Display	Mounting	Power
FWS-2273E7-A10-A10-00	Intel® Celeron® N3350	204-pin DDR3L SODIMM socket x 1	2 pairs	Full Size x 1 (PCIe + USB) with SIM socket Full Size x 1 (USB signal) with SIM socket	CF socket x 1 2.5" HDD Bay x 1	6	USB 3.2 Gen 1 x 2	RJ-45 x 1	Fanless	—	HDMI x 1	Desktop	DC

Packing List

- SATA Cable x 1
- SATA Power Cable x 1
- Power Adapter
- FWS-2273

Optional Accessories

- **1700091805**
Console Cable
- **1702031802**
Power Cord, 3P-250V/10A, 180D, 1.8M, USA, YP22/YP12
- **1702031803**
Power Cord, 3P-250V/10A, 180D, 1.8M, VDE, YP22/YP12
- **170203180B**
Power Cord, 3P-250V/10A, 180D, 1.8M, China, YP-03/YC-12
- **170203180E**
Power Cord, 3P-250V/10A, 180D, 1.8M, PSE, YP12/YC-12

FWS-2272

Desktop 4 LAN Ports Network Appliance with Intel® Celeron® N3350 Processor SoC

Front View



Rear View

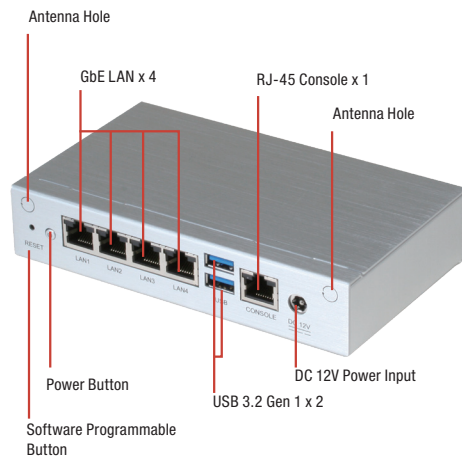

Features

- Intel® Celeron® N3350 Processor SoC
- Onboard LPDDR4 1 GB Memory
- 10/100/1000Base-TX x 4
- Onboard 8GB eMMC, SATA 6.0 Gb/s Port x 1
- Mini-Card Slot (with SIM Socket) x 1
- RJ-45 Console x 1, USB 3.2 Gen 1 x 2



Internal/ Expansion Interface

PCIe Slot	—
Mini-PCIe Slot	Mini-Card socket (full-size) with SIM socket x 1
Keyboard and Mouse	—
USB	USB 3.2 Gen 1 x 2

Miscellaneous

RTC	Internal RTC
Watchdog Timer	1~255 steps by software programmable
Software Button	—
TPM	(TPM v1.2 9660/TPM2.0 9665 Optional)
GPIO	Reserved internal pin-header 8-bit Digital I/O interface (4-in /4-out)
Fan	Fanless
MTBF (Hours)	162,469
Color	Silver

Environmental Parameters and Dimension

Power Requirement	12V DC Power in connector
Operating Temperature	32°F ~ 104°F (0°C ~ 40°C)
Storage Temperature	-4°F ~ 140°F (-20°C ~ 60°C)
Operating Humidity	10%~80% relative humidity, non-condensing
Storage Humidity	10%~80% @40°C; non-condensing
Vibration	0.5 Grms/ 5 ~ 500Hz / operation (SATA DOM) 1.5 Grms/ 5 ~ 500Hz / non operation
Shock	10 G peak acceleration (11 m sec. duration), operation 20 G peak acceleration (11 m sec. duration), non operation
Dimension (W x D x H)	6.1" x 3.62" x 1.26" (155mm x 92mm x 32mm)

I/O

Front Panel	Power LED x 1 Status LED x 1 Storage Active LED x 1 LAN LED x 8
Rear Panel	USB 3.2 Gen 1 Port x 2 RJ-45 Port x 4 RJ-45 Console x 1 12V DC Power Input x 1 Software Reset Button x 1 Power Button x 1 Antenna Hole x 2

Specifications

System	
Form Factor	Desktop Network Appliance
Processor	Intel® Celeron® N3350 Processor
Chipset	Intel® Celeron® N3350 Processor
System Memory	Onboard LPDDR4 1GB memory. Optional BOM SKU supports 204-pin DDR3L SODIMM x 1, up to 8GB
Network	
Ethernet	Intel® i211, Gigabit Ethernet x 4
Bypass	—
Display	
Graphic Controller	Intel® HD Graphics 505 Intergrated
Connector	—
Storage	
HDD	—
CF/CFAST/MSATA	Onboard 8GB eMMC SATA 6.0 Gb/s port x 1, for SATA DOM

Dimension

Unit: mm

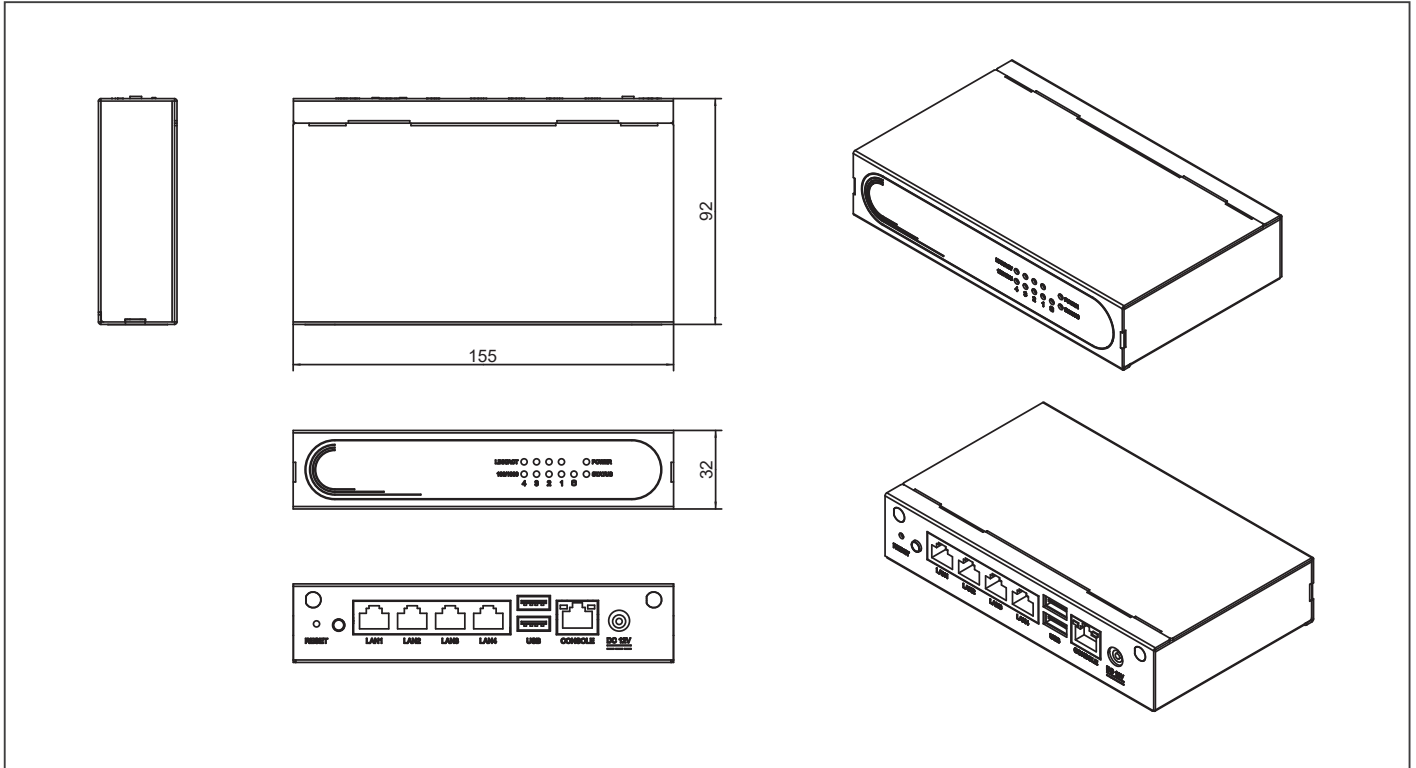

Ordering Information

Part Number	CPU	Memory	Bypass	Mini-Card Slot	Storage	LAN	USB	Console	System Fan	TPM	Display	Mounting	Power
FWS-2272E4-A10-A10-00	Intel® Celeron® N3350	Onboard 1GB LPDDR4	—	Full Size (USB Only)+ SIM socket x 1	Onboard 8GB eMMC, SATA 6.0 Gb/s Port x 1	4	USB 3.2 Gen 1 x 2	RJ-45 x 1	Fanless	—	—	Desktop	DC

Packing List

- Power Adapter
- FWS-2272

Optional Accessories

- **1700091805**
Console Cable
- **1702021832**
Power Cord, 2P/2P, 1.8M, USA
- **1702021836**
Power Cord, 2P/2P, 1.8M, EU

FWS-2271

Desktop 6 LAN Ports Network Appliance with Intel® N3350 Processor SoC

Front View

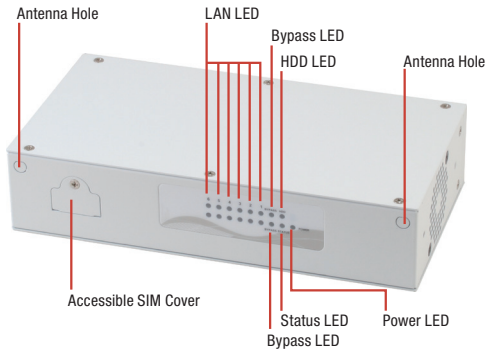

Rear View

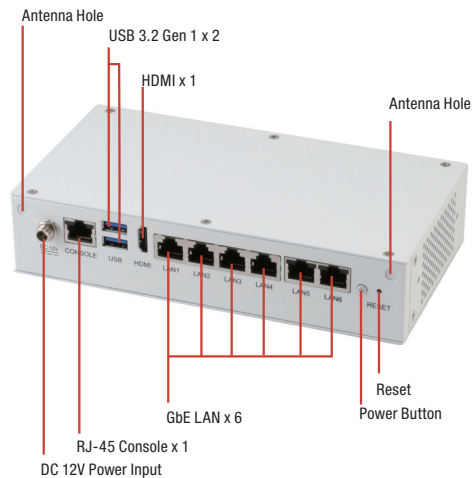

Specifications

System	
Form Factor	Desktop 6-port Network Appliance
Processor	Onboard Intel® Celeron® processor N3350
Chipset	Integrated
System Memory	204-pin DDR3L 1867MHz SODIMM Up to 1, 8 GB
Network	
Ethernet	Intel® i211 (Co-lay with Intel® i210), Gigabit Ethernet x 6 (BOM Optional 4 Ports)
Bypass	Supports up to 2 pairs bypass function
Display	
Graphics Controller	Intel® HD Graphics 505 Intergrated
Connector	HDMI x 1
Storage	
HDD	2.5" HDD Bay x 1
CF/CFast/mSATA	CFast™ socket x 1 (Co-lay for BOM Optional CompactFlash™ socket x 1)

Features

- Intel® N3350 Processor SoC
- 204-pin Dual-channel DDR3L 1867MHz SODIMM Up to 1, 8 GB
- 10/100/1000Base-TX Ethernet Port x 6
- CFast™ Socket x 1
- Mini-Card Slot x 2 (USB Signal only with SIM Socket x 1)
- Accessible SIM Cover
- Supports TPM
- RJ-45 Console x 1, USB 3.2 Gen 1 x 2, HDMI x 1
- Supports Antenna up to 4



Internal/ Expansion Interface

PCIe Slot	—
Mini-PCIe Slot	Mini-Card socket (full-size) with SIM socket x 2
Keyboard and Mouse	Reserved pin-header
USB	USB 3.2 Gen 1 Type A on I/O side x 2

Miscellaneous

RTC	Internal RTC
Watchdog Timer	1~255 steps by software programmable
Software Button	GPIO Programmable push button x 1
TPM	Optional TPM v1.2 9660/TPM2.0 9665
GPIO	Reserved internal pin-header 8-bit Digital I/O interface (4-in /4-out)
Fan	System Fan x 1
MTBF (Hours)	118,725
Color	White

Environmental Parameters and Dimension

Power Consumption	12V DC In/ 40W power adapter x 1
Operating Temperature	32°F ~ 104°F (0°C ~ 40°C)
Storage Temperature	-4°F ~ 140°F (-20°C ~ 60°C)
Operating Humidity	10%~80% relative humidity, non-condensing
Storage Humidity	10%~80% @40°C, non-condensing
Vibration	0.5 Grms/ 5 ~ 500Hz/ operation (2.5" Hard Disk Drive) 1.5 Grms/ 5 ~ 500Hz/ non-operation
Shock	10 G peak acceleration (11 m sec. duration), operation 20 G peak acceleration (11 m sec. duration), non-operation
Dimension (W x D x H)	7.87" x 4.13" x 1.73"(200mm x 105mm x 44 mm)

I/O

Front Panel	Bypass LED x 2 Power LED x 1 Status LED x 1 HDD Active LED x 1 LAN LED x 12
Rear Panel	USB 3.2 Gen 1 Port x 2 RJ-45 Port x 6 (BOM Optional RJ-45 Port x 4) RJ-45 Console x 1 12V DC Power Input x 1 Software Programmable button x 1 HDMI x 1 Power Button x 1

Dimension

Unit: mm

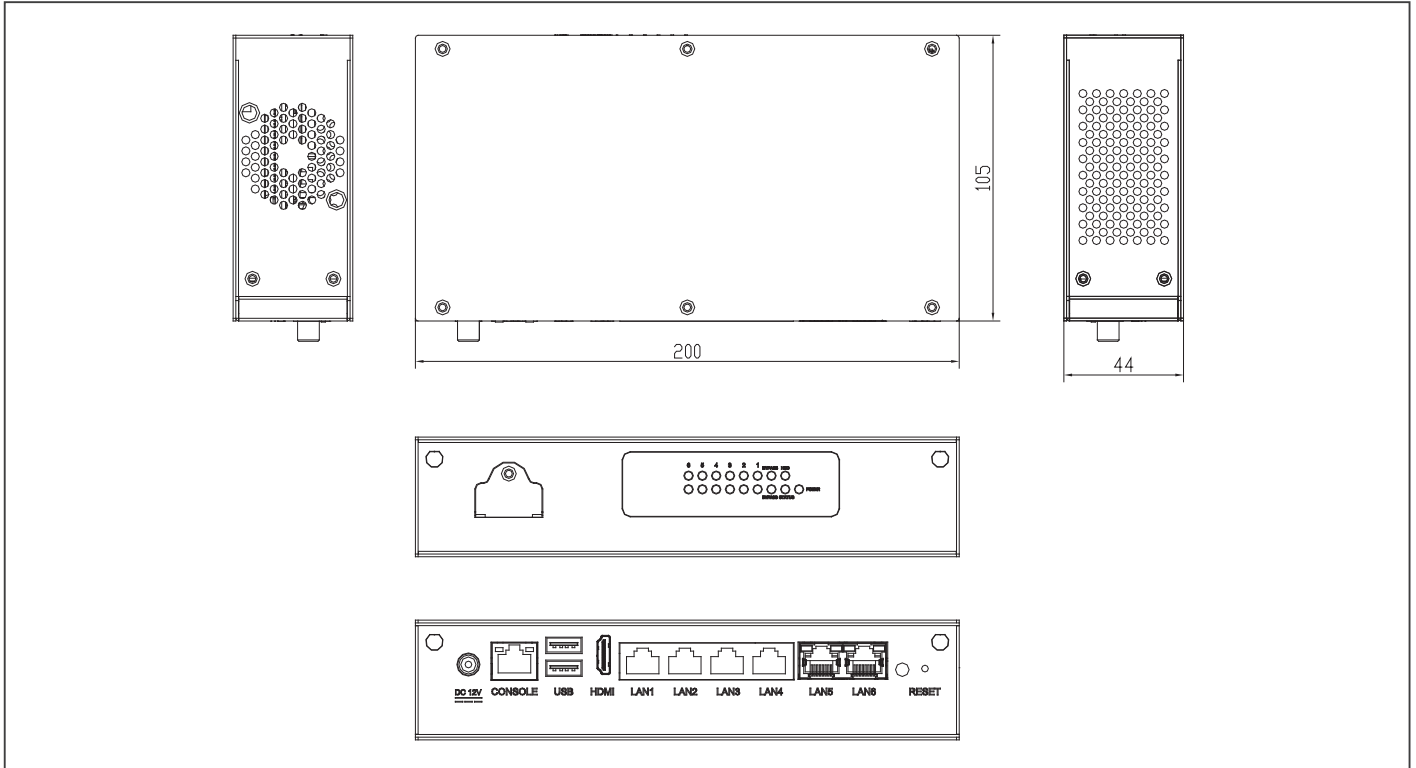

Ordering Information

Part Number	CPU	Memory	Bypass	Mini-Card Slot	Storage	LAN	USB	Console	System Fan	TPM	Display	Mounting	Power
FWS-2271E6-A10-A10-00	Intel® Celeron® N3350	DDR3L, SODIMM Single Channel	2 pairs	Full Size (PCIe+USB) x 1 Full Size (USB Only) + SIM socket x 1	SATA II Port x 1, CFast™ socket x 1	6	USB 3.2 Gen 1 x 2	RJ-45 x 1	Fan x 1	—	HDMI x 1	Desktop	DC

Packing List

- SATA Cable x 1
- SATA Power Cable x 1
- Power Adapter
- FWS-2271

Optional Accessories

- **1700091805**
Console Cable
- **1702031802**
Power Cord, 3P-250V/10A, 180D, 1.8M, USA, YP22/YP12
- **1702031803**
Power Cord, 3P-250V/10A, 180D, 1.8M, VDE, YP22/YP12
- **170203180B**
Power Cord, 3P-250V/10A, 180D, 1.8M, China, YP-03/YC-12
- **170203180E**
Power Cord, 3P-125V/7A, 1.8M, PSE, YP12/YC-12

Desktop Network Appliance with Intel® Celeron® Processor N3350 SoC (formerly Apollo Lake)

Front View



USB 3.2 Gen 1 x2

Power switch

Rear View



12V DC jack

RJ45 1GbE x2

HDMI

With Antennas installed



(Antennas: Optional Accessories)

Features

- Desktop Network Appliance
- Intel® Celeron® Processor N3350 SoC
- Onboard eMMC 16GB (Optional up to 32GB)
- Intel® i211 GbE x 2,
- Mini-Card full size with wifi (11a/b/g/n/ac 2Tx2R) + BT (V5.0 LE)
- Onboard LPDDR4, 4GB
- TPM Supported (Optional)

Internal/ Expansion Interface

PCIe Slot	—
Mini-PCIe Slot	Mini-Card Full Size Slot x1
Keyboard and Mouse	—
USB	USB 3.2 Gen 1 x 2
Miscellaneous	
RTC	Internal RTC
Watchdog Timer	1~255 steps by software programmable
Software Button	GPIO Programmable push button x 1
TPM	(TPM SLB9670 VQ2.0 FW7.85 Optional)
GPIO	(4 bits input, 4bits output optional)
Fan	Fan-less
MTBF (Hours)	TBD
Color	Black

Environmental Parameters and Dimension

Power Consumption	12V DC Power Input Connector Lockable, 40W power adapter
Operating Temperature	32°F ~ 104°F (0°C ~ 40°C)
Storage Temperature	-4°F ~ 140°F (-20°C ~ 60°C)
Operating Humidity	10%~80% relative humidity, non-condensing
Storage Humidity	10%~80% @40°C; non-condensing
Vibration	0.5 Grms/ 5 ~ 500Hz / operation (mSATA) 1.5 Grms/ 5 ~ 500Hz / non-operation
Shock	10 G peak acceleration (11 m sec. duration), operation 20 G peak acceleration (11 m sec. duration), non-operation
Dimension (W x D x H)	4.53" x4.53" x 1.26"(115mm x115mm x 32mm)

I/O

Front Panel	USB 3.2 Gen 1 x 2 Power Button x 1 Reset Button x 1
Rear Panel	DC Power Input Connector non-lock x 1 1GbE RJ45 Ports x 2 HDMI x 1

Specifications

System	
Form Factor	Desktop Network Appliance
Processor	Intel® Celeron® Processor N3350 SoC
Chipset	SoC
System Memory	Onboard LPDDR4, 4GB
Network	
Ethernet	Intel® i211, Gigabit Ethernet x 2
Bypass	—
Display	
Graphics Controller	Intel® UHD Graphics
Connector	HDMI x 1
Storage	
HDD	—
CF/CFast/mSATA	—

Dimension

Unit: mm

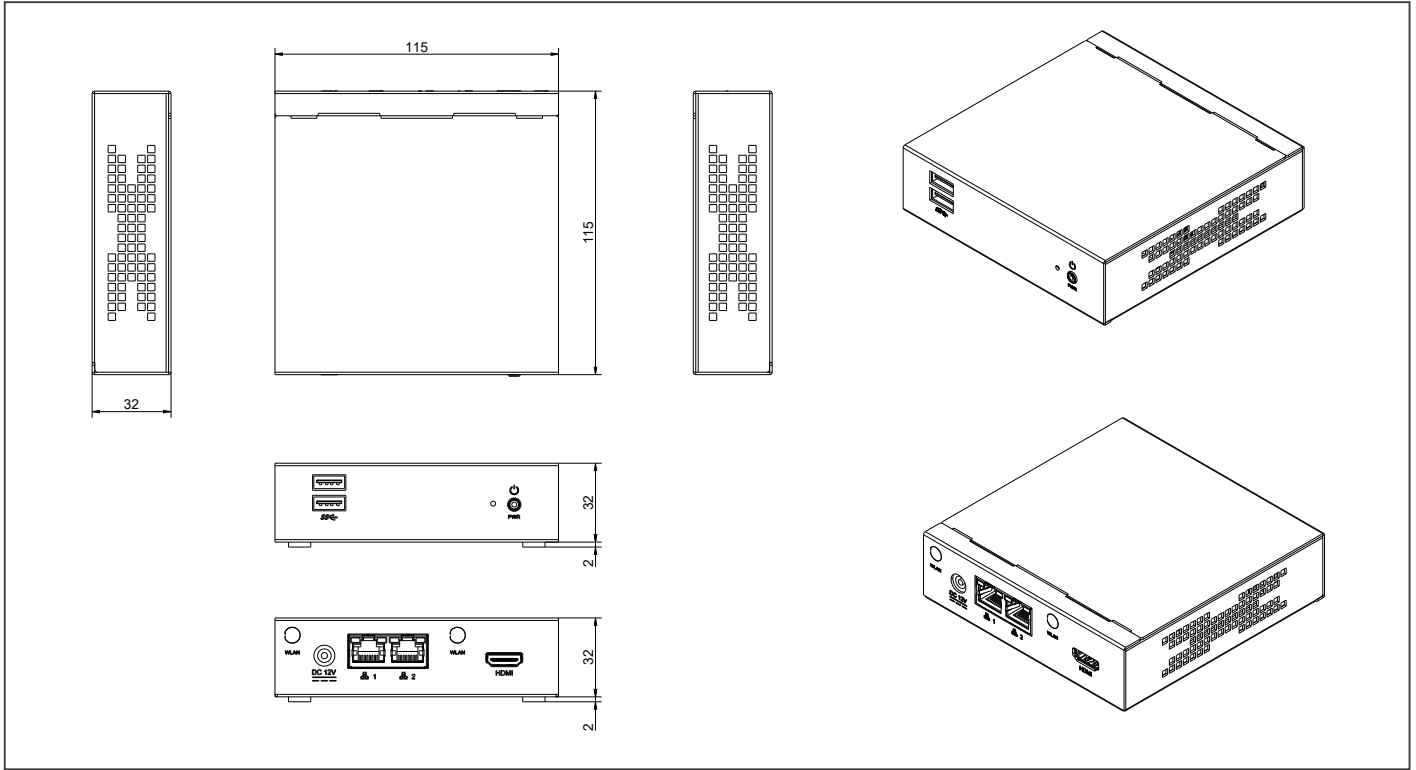

Ordering Information

Part Number	CPU	Memory	Bypass	Mini-Card Slot	Storage	LAN	USB	Console	System Fan	TPM	Display	Mounting	Power
FWS-2277-E2-A10-00	N3350	Onboard LPDDR4, 4G	—	Mini Card Socket x1	Intel® i211 Gigabit Ethernet x 2	6	USB 3.1 x 2	—	Fan-less	Optional	HDMI x 1	Desktop	DC

Packing List

- Power Adapter x1
- FWS-2277

Optional Accessories

- **1702021832**
Power Cord, 2P/2P, 1.8M, USA
- **1702021836**
Power Cord, 2P/2P, 1.8M, EU

02

► Rackmount Network Appliances & Network Interface Modules



02



FWS-8600

2U Rackmount Network Appliance with Dual 2nd Gen Intel® Xeon® Scalable Processors

Front View



Rear View



Specifications

System	
Form Factor	2U Rackmount Network Platform
Processor	Dual 2nd Gen Intel® Xeon® Scalable Processors, up to 56 cores, 112 threads
Chipset	Intel® C621 Chipset
System Memory	DDR4 2133/2400/2666 R-DIMM x 16 (8 DIMM per CPU), Up to 512 GB
Network	
Ethernet	Intel® i211 Gigabit Ethernet x 2
Bypass	Depend on NIM module
NIM Slot	NIM x 4 (Project based up to 8 slots)
Display	
Graphic Controller	Optional support via Mini-PCIe module or IPMI
Connector	Optional VGA port via module

Features

- 2U Rackmount Network Appliance
- Dual 2nd Gen Intel® Xeon® Scalable Processors
- Intel® C621 Chipset
- DDR4 2133/2400/2666 MHz RDIMM x 16, up to 512GB
- 1GbE RJ45 Intel® i211 x 2, NIM slot x 4 (Project based up to 8 slots)
- IPMI supported by AAEON Module
- External Hotswappable 3.5" HDD Bay x 4, Internal 3.5" HDD Bay x 1
- Mini-Card slot x 1, M.2 2260 M-key x 1
- RJ-45 Console x 1, USB 3.2 Gen 1 x 2
- 550W ~ 600W Redundant Power



Storage	
HDDs	SATA III Port x 6 External Hotswappable 3.5" HDD Bay x 4 Internal 3.5" HDD Bay x 1, option with 2.5" HDD Bay x 2
CF/CFast/mSATA	M.2 2260 M-key x 1 mSATA slot x 1 (share same slot with Mini-Card)
Internal/ Expansion Interface	
PCIe slot	Optional PCIe [x16] slots x 2, via riser card
Mini-Card slot	Mini Card slot (full-size) x 1 (PCIe/SATA, USB2.0)
IPMI	Optional IPMI via AAEON Module (Project based)
Keyboard and Mouse	—
USB	USB 3.2 Gen1 x 2 (Optional 2*10 pin USB 3.2 Gen1 x 2 Box Header 2.0mm)
Miscellaneous	
RTC	Internal RTC
Watchdog Timer	1~255 steps by software programmable
Software Button	GPIO Programmable push button x 1
TPM	(Optional TPM2.0 9665 on board)
GPIO	(4 bits input, 4 bits output optional)
FAN	5 x Hotswappable FAN
MTBF (Hours)	192,691 Hours
Color	Black
Environmental Parameters and Dimension	
Power Requirement	550 ~ 600W Redundant Power
Operating Temperature	32°F ~ 104°F (0°C ~ 40°C)
Storage Temperature	-4°F ~ 140°F (-20°C ~ 60°C)
Operating Humidity	10% ~ 80% relative humidity, non-condensing
Storage Humidity	10% ~ 80% @40°C; non-condensing
Vibration	0.5 Grms/ 5 ~ 500Hz / operation (3.5" Hard Disk Drive x 5) 1.5 Grms/ 5 ~ 500Hz / non operation
Shock	10 G peak acceleration (11 m sec. duration), operation 20 G peak acceleration (11 m sec. duration), non operation
Dimension (W X D X H)	17.48" x 22.83" x3.46" (444mm x 580mm x 88mm)
I/O Interfaces	
Front Panel	Power LED x 1 Status LED x 1 HDD Active LED x 1 USB 3.2 Gen 1 Ports x 2 RJ-45 Console x 1 Parallel LCM display and 4 keypad x 1 Software Programmable Button x1 RJ-45 LAN x 2 IPMI x 1 (Project based)
Rear Panel	AC Power Input x 2, Power Switch x 1, VGA port (Optional), Rear Expansion Slot x 2 (PCIe [x16] Optional)

Dimension

Unit: mm

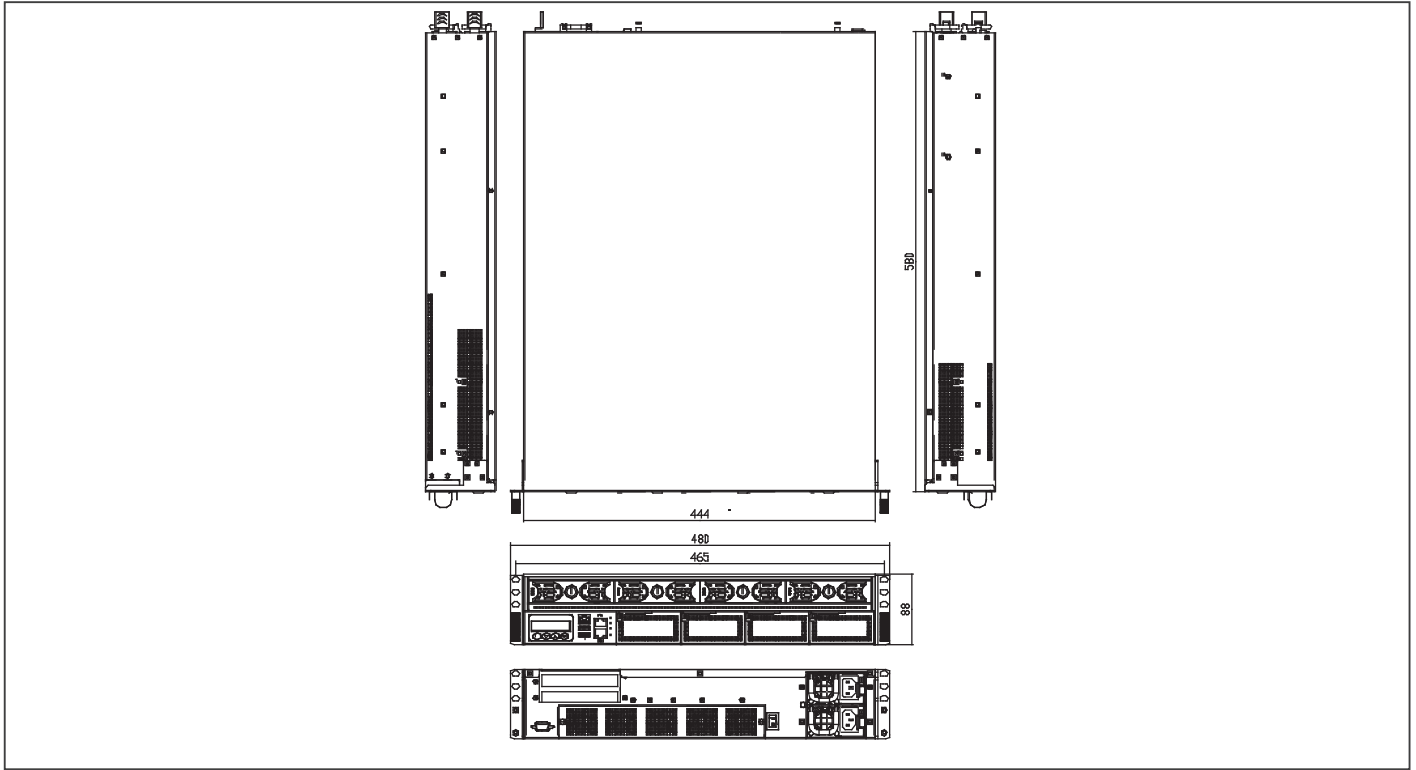

Ordering Information

Part Number	CPU	RAM	Mini-Card Slot	Storage	LAN	USB	Console	Bypass	NIM Slot	Expansion Slot	TPM	Display	Fan	Mounting	Power
FWS-8600S2-R60-A10-00	Dual 2nd Gen Intel® Xeon® Scalable Processors	DDR4 RDIMM x 16, Up to 512GB	Mini-Card slot x 1 (PCIe/SATA, USB2.0)	External 3.5" HDD Bay x 4, Internal 3.5" HDD Bay x 1, M.2 2260 M-key x 1	Intel® i211 Gigabit Ethernet x 2	USB 3.2 Gen1 x 2	RJ-45 console x 1	—	4	—	—	—	5	2U Rackmount	600W Redundant Power

Packing List

- Gift Box (Including Console Cable x 1, 3.5" HDD Tray Kit x 1, External HDD Bay Key x 1, Ear Bracket Kit x 1)
- CPU Cooler x 2
- FWS-8600

Optional Accessories

- **M028500000**
Slide x 2, Chassis Rail Kit
- **9761EMPV02**
Mini-PCIe VGA module Kit.Full Size.Innodisk EMPV-1201-C1.w/Packing
- **1702031803**
Power Cord, 3P-250V/10A, 180D, 1.8M, VDE, YP22/YP12
- **1702031802**
Power Cord, 3P-250V/10A, 180D, 1.8M, USA, YP22/YP12
- **170203180E**
Power Cord, 3P-25V/7A, 180D, 1.8M, PSE, YP12/YP12
- **PER-T488-A10-00**
PER-T488.Riser Card.PCIe[x16] slot x2.Rev.A1.0.for FWS-8600
- **NIM-S26C-A10-T40-0002**
Intel® Fortville XL710 PCI-Express 10G SFP+ 4 Ports Module
- **NIM-S26B-A10-F20-0002**
Intel® Fortville XL710 PCI-Express 40G QSFP 2 Ports Module
- **NIM-S13B-A10-G80-0002**
Intel® 82580EB PCI-Express 1G SFP 8 Ports Module
- **NIM-S13D-A10-G40-0002**
Intel® 82580EB PCI-Express 1G SFP 4 Ports
- **NIM-C13B-A10-G82-0001**
Intel® 82580EB PCI-Express 1G Copper Ethernet 8 Ports Module w/ 2Pair bypass
- **NIM-C13D-A10-G42-0002**
Intel® 82580EB PCI-Express 1G Copper Ethernet 4 Ports Module w/ 2Pair bypass

1U Rackmount Network Appliance with Intel® Xeon® LCC Processor (formerly ICE-Lake-D)

Front View

Launching in Q2

Rear View

Features

- 1U Rackmount Network Appliance
- Intel® Xeon® ICE-Lake-D LCC Processor
- SOC PCH
- DDR4 SO-DIMM ECC DIMM slots x2
- IPMI Support
- SFP x 4+ from CPU
- RJ45 I350-AM4 LAN Chip x 12
- NIM Slot (Option) x 1
- M.2 B-Key(Colay Mini PCIe) x 1
- M.2 E-Key(Colay Mini PCIe) x 1
- TPM 2.0
- 2.5" SATA HDD x 2
- Real PCIe x 16 expansion slot(Optional)
- 1 x LCM with Keypad x 1
- RJ-45 Console x 1, USB 3.0 x 2
- 220W Power

Specifications

System	
Form Factor	1U Rackmount ICE-Lake-D LCC Platform Network Appliance
Processor	Intel® Xeon® ICE-Lake-D LCC Processors
Chipset	SoC
System Memory	DDR4 SO-DIMM ECC DIMM slots x 2
Network	
Ethernet	Intel® i350-AM4 Gigabit Ethernet x 12 and SFP+ x 4 from CPU
Bypass	2 pairs
NIM Slot	NIM Slot x 1 (Option)
Display	
Graphic Controller	—
Connector	—
Storage	
HDDs	2.5" HDD x 2
CF/CFast/msATA	—

Internal/ Expansion Interface	
PCIe slot	Rear Expansion PCIe x 16 Slot x 1(Optional)
Mini-Card slot	M.2 B-Key Slot x 1(Optional Mini PCIe slot) M.2 E-Key Slot x 1(Optional Mini PCIe slot)
IPMI	Option
Keyboard and Mouse	—
USB	USB 3.0 x 2
Miscellaneous	
RTC	—
Watchdog Timer	1~255
Software Button	1
TPM	2
GPIO	8Pin
FAN	2
MTBF (Hours)	—
Color	Fan
Environmental Parameters and Dimension	
Power Requirement	—
Operating Temperature	32°F ~ 104°F (0°C ~ 40°C)
Storage Temperature	-4°F ~ 140°F (-20°C ~ 60°C)
Operating Humidity	10%~80% relative humidity, non-condensing
Storage Humidity	0%~80% @40°C; non-condensing
Vibration	0.5 g rms/ 5 ~ 500Hz / operation (2.5" Hard Disk Drive) 1.5 g rms/ 5 ~ 500Hz / non operation
Shock	10 G peak acceleration (11 m sec. duration), operation 20 G peak acceleration (11 m sec. duration), non operation
Dimension (W X D X H)	16.93" x 7.87" x 1.73"(430mm x 200mm x 44mm)
I/O Interfaces	
Front Panel	Power LED x 1 Status LED x 1 HDD Active LED x 1 USB 3.1Ports x 2 RJ-45 Console x 1 RJ-45 IPMI Port x 1 parallel LCM display and 4 keypad Software Programmable Button x 1 SFP x 4+ Port4x SFP+ (from CPU) RJ45 Port x 12
Rear Panel	AC Power Input x 1 Power Switch x1 Rear Expansion Slot (Optional PCIe [x8 or x16]) x 1

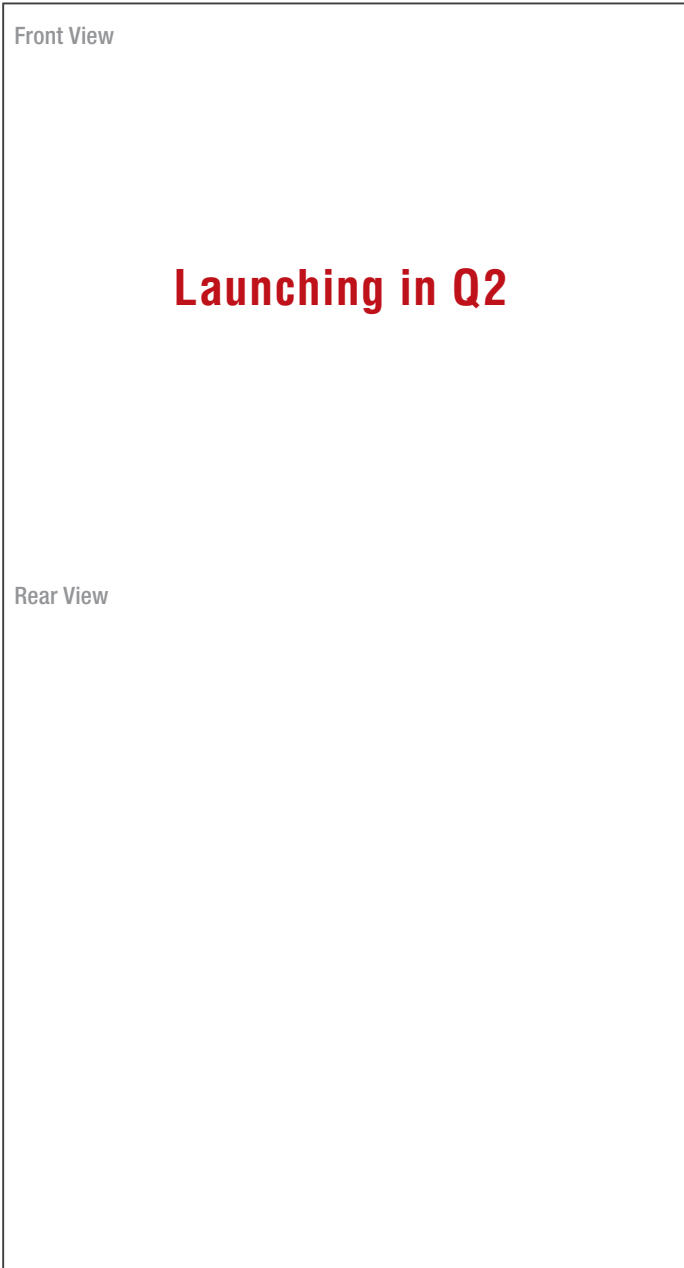

Launching in Q2

Features

- 1U Rackmount Network Appliance
- Intel® Xeon® ICE-Lake-D HCC Processor
- SOC PCH
- DDR4 U-DIMM R-DIMM slots x 4
- IPMI Support
- SFP+ from CPU x 8
- RJ45 I350-AM4 LAN Chip x 8
- NIM Slot x 2
- Min PCIe (Colay M.2 B-Key) x 1
- Mini PCIe (Colay M.2 E-Key) x 1
- M.2 M-Key 2280 x 1
- TPM 2.0
- 2.5" SATA HDD x 2
- Real PCIe x 16 expansion slot(Option)
- RJ-45 Console x 1, USB 3.0 x 2
- 220W Power

Specifications

System	
Form Factor	1U Rackmount ICE-Lake-D HCC Platform Network Appliance
Processor	Intel® Xeon® ICE-Lake-D HCC Processors
Chipset	SoC
System Memory	DDR4 U-DIMM R-DIMM slots x 4
Network	
Ethernet	Intel® i350-AM4 Gigabit Ethernet x 8 and SFP+ x 4 from CPU
Bypass	—
NIM Slot	NIM Slot x 2
Display	
Graphic Controller	—
Connector	—
Storage	
HDDs	2.5" HDD x 2
CF/CFast/mSATA	M.2 M-Key 2280

Internal/ Expansion Interface	
PCIe slot	Rear Expansion PCIe x 16 Slot x 1(Option)
Mini-Card slot	Mini PCIe slot with SIM(Option M.2 B-Key) x 1 Mini PCIe slot with SIM(Option M.2 E-Key) x 1
IPMI	Option
Keyboard and Mouse	—
USB	USB 3.0 x 2
Miscellaneous	
RTC	—
Watchdog Timer	1~255
Software Button	1
TPM	2
GPIO	8Pin
FAN	2
MTBF (Hours)	—
Color	Fan
Environmental Parameters and Dimension	
Power Requirement	—
Operating Temperature	32°F ~ 104°F (0°C ~ 40°C)
Storage Temperature	-4°F~ 140°F (-20°C ~ 60°C)
Operating Humidity	10%~80% relative humidity, non-condensing
Storage Humidity	0%~80% @40°C; non-condensing
Vibration	0.5 g rms/ 5 ~ 500Hz / operation (2.5" Hard Disk Drive) 1.5 g rms/ 5 ~ 500Hz / non operation
Shock	10 G peak acceleration (11 m sec. duration), operation 20 G peak acceleration (11 m sec. duration), non operation
Dimension (W X D X H)	16.93" x 7.87" x 1.73"(430mm x 200mm x 44mm)
I/O Interfaces	
Front Panel	Power LED x 1 Status LED x 1 HDD Active LED x 1 USB 3.1Ports x 2 RJ-45 Console option Micro USB console x 1 RJ-45 IPMI Port When install the IPMI card (NC-SI interface or IPMI Module LAN) x 1 Software Programmable Button x 1 SFP+ Port (from CPU) x 8 8+2 x RJ45 Port w/o IPMI with IPMI 8+1 x RJ45 2 NIM Slot
Rear Panel	AC Power Input x 1 Power Switch x 1 Rear Expansion Slot (Optional PCIe [x8 or x16]) x 1 If with NIM only PCIe x 8 (PER-R30X or TBD) If No NIM PCIe x 16 (Create new Riser card)

FWS-7840

1U Rackmount Network Appliance with 10th Generation Intel® Core™/ Xeon® processor (formerly Comet Lake)

Front View



Rear View



Features

- 1U Rackmount Network Appliance
- 10th Generation Intel® Core™/ Xeon® processor
- Intel® Communications Chipset W480E
- 2 x DDR4 2666MHz U-DIMM ECC DIMM slots
- 8 x 1Gb RJ45 Port or 6 x 1Gb RJ45 + 2 x 1Gb SFP , with 2 x i350AM4 LAN Chips
- 2 x 10Gb SFP+ with XL710 AM2 LAN Chip (Option)
- 2 x NIM Slots
- 1 x RJ45 console Port (Option Micro USB console)
- 1 x Mini PCIe (Option mSATA)
- 2 Pairs Bypass default



Storage	
HDDs	SATA III port x 2, 2.5" HDD/SSD up to 2
CF/CFast/mSATA	1 x Mini card socket (Option mSATA)
Internal/ Expansion Interface	
PCIe slot	Optional PCIe [x8] slot x 1, via riser card
Mini-PCIe slot	Mini Card x 1
IPMI	—
Keyboard and Mouse	—
USB	USB 3.2 Gen1 x 2
Miscellaneous	
RTC	Internal RTC
Watchdog Timer	1~255 steps by software programmable
Software Button	GPIO Programmable push button x 1
TPM	TPM v2.0 9665
GPIO	4 bits input/4 bits output
FAN	System Fan x 2
MTBF (Hours)	TBD
Color	Black
Environmental Parameters and Dimension	
Power Requirement	220W ATX PSU or 250W ATX PSU
Operating Temperature	32°F ~ 104°F (0°C ~ 40°C)
Storage Temperature	-4°F ~ 140°F (-20°C ~ 60°C)
Operating Humidity	10% ~ 80% relative humidity, non-condensing
Storage Humidity	10% ~ 80% @ 40°C, non-condensing
Vibration	0.5 Grms/ 5 ~ 500Hz/ operation (3.5" H.D.D) 1.5 Grms/ 5 ~ 500Hz/ no operation
Shock	10G peak acceleration (11 m sec. duration), operation 20G peak acceleration (11 m sec. duration), non-operation
Dimension (W X D X H)	430mm x 305mm x 44mm
I/O Interfaces	
Front Panel	Power LED x 1 Status LED x 1 Storage Active LED x 1 Bypass LED x 2 Ethernet LED x 16 USB 3.2 Type A port x 2 Parallel LCM display and 4 keypad x 1 Software Programmable Switch x 1 1 GbE RJ-45 x 8 or 1 GbE RJ45 x 6 + SFP x 2 10 GbE SFP+ x 2/LAN port (Option by module) NIM Slot x 2
Rear Panel	AC Power Input x 1, Power Switch x 1, (Rear Expansion Slot x 1 Optional)

Specifications

System	
Form Factor	1U Rackmount Network Platform
Processor	10th Generation Intel® Core™/ Xeon® processor
Chipset	Intel® W480E
System Memory	2 x DDR4 2666MHz U-DIMM ECC DIMM slots up to 64G
Network	
Ethernet	8 x 1Gb RJ45 Port or 6 x 1Gb RJ45 + 2 x 1Gb SFP , with 2 xi350AM4 LAN chips 2 x 10Gb SFP+ with XL710 AM2 LAN chip (Option)
Bypass	2 Pairs
NIM Slot	NIM slot x 2
Display	
Graphic Controller	Intel® UHD Graphics
Connector	(HDMI x1 Optional)

Dimension

Unit: mm

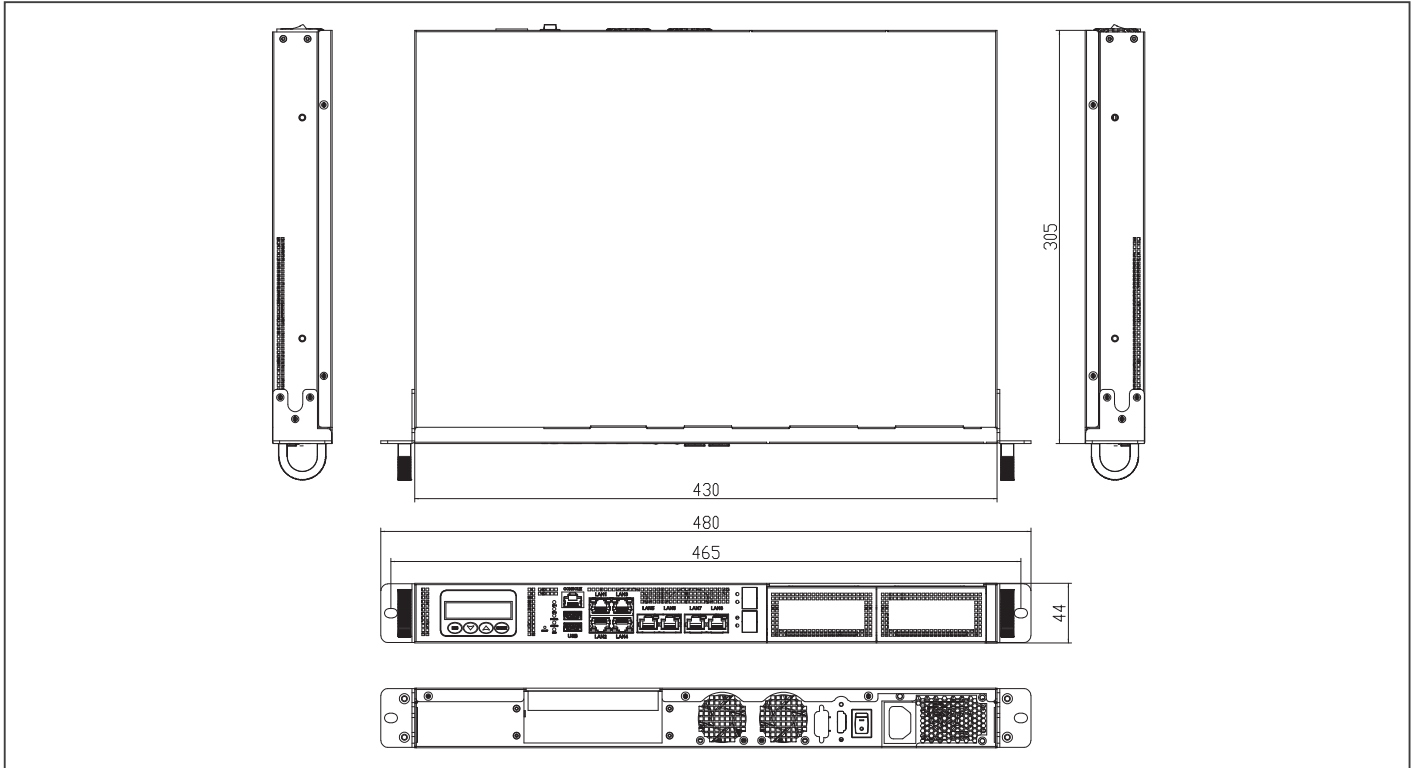

Ordering Information

- **FWS-7840-E8-A10-00**

1U FWS, Comet Lake W480E A1. 0. I350 A,M4 GbEx 8. 220W PSU. 2. 5" HDDx2. USB 3. 0 x 2. LCM

Packing List

- Console Cable
- Ear Brackets
- SATA Cable x 2
- SATA Power Cable x 2
- HDD Kit x 1
- FWS-7840

Optional Accessories

- **M02666600**
Slide x 2, for Rackmount Usage
- **1702031803**
Power Cord, 3P-250V/10A, 180D, 1.8M, VDE, YP22/YP12
- **1702031802**
Power Cord, 3P-250V/10A, 180D, 1.8M, USA, YP22/YP12
- **170203180E**
Power Cord, 3P-25V/7A, 180D, 1.8M, PSE, YP12/YP12
- **9761783102**
HDMI Cable
- **PER-T639**
2Port SFP+ Module
- **PER-T629**
NIM Riser card
- **PER-T636**
Real expansion riser card
- **NIM-S26C-A10-T40-0002**
Intel® Fortville XL710 PCI-Express 10G SFP+ 4 Ports Module
- **NIM-S26B-A10-F20-0002**
Intel® Fortville XL710 PCI-Express 40G QSFP 2 Ports Module
- **NIM-S13B-A10-G80-0002**
Intel® 82580EB PCI-Express 1G SFP 8 Ports Module
- **NIM-S13D-A10-G40-0002**
Intel® 82580EB PCI-Express 1G SFP 4 Ports
- **NIM-C13B-A10-G82-0001**
Intel® 82580EB PCI-Express 1G Copper Ethernet 8 Ports Module w/ 2Pair bypass
- **NIM-C13D-A10-G42-0002**
Intel® 82580EB PCI-Express 1G Copper Ethernet 4 Ports Module w/ 2Pair bypass

FWS-7830

1U Rackmount Intel® 8th Generation Platform Network Appliance

Front View

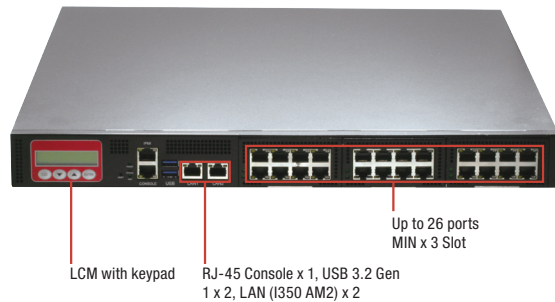

Rear View

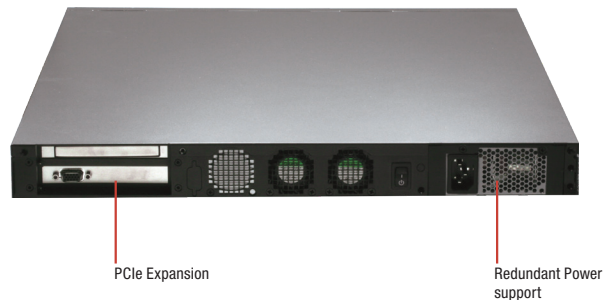

Specifications

System	
Form Factor	1U Rackmount Network Platform
Processor	8th Generation Intel® Core™/ Xeon® processor
Chipset	Intel® C246
System Memory	DDR4 2133/2400/2666 UDIMM Up to 64GB 288-pin DIMM x 4
Network	
Ethernet	Intel® I350 AM2 Gigabit Ethernet x 2
Bypass	Depend on NIM module
NIM Slot	NIM Slot x 3
Display	
Graphic Controller	Intel® HD graphics integrated
Connector	VGA cable (Optional)

Features

- 1U Rackmount Network Appliance
- Single Intel® 8th Generation Core™/Xeon™ processor
- Intel® Communications Chipset C246
- DDR4 2133/2400/2666 MHz UDIMM x 4, Up to 64 GB
- IPMI Support by Aeon Module
- Onboard 2 LAN (I350 AM2)
- Up to 24 Gigabit Ethernet Ports Via NIM
- 1 x 3.5" SATA HDD or 2.5" SATA HDD x 2, mSATA Socket x 1
- LCM with Keypad x 1
- RJ-45 Console x 1, USB 3.2 Gen 1 x 2, 1 GbE LAN x 2
- 220W Single Power or 250W Single Power



Storage	
HDDs	Internal 2.5" SATA HDD x 2 or 3.5" SATA HDD x 1 (Optional)
CF/CFast/mSATA	Default mSATA Slot (Optional CFast™ Socket)
Internal/ Expansion Interface	
PCIe slot	Optional PCIe [x8] slot x 1, via riser card
Mini-PCIe slot	Mini Card x 1
IPMI	—
Keyboard and Mouse	Pin-header
USB	USB 3.2 Gen 1 x 2, Box Header (2.0mm)
Miscellaneous	
RTC	Internal RTC
Watchdog Timer	1~255 steps by software programmable, 1 sec per step
Software Button	GPIO Programmable push button x 1
TPM	Optional TPM v2.0
GPIO	8bits, BIOS default 4bits input, 4bits output.
FAN	2
MTBF (Hours)	TBD
Color	Black
Environmental Parameters and Dimension	
Power Requirement	220W ATX PSU or 250W ATX PSU
Operating Temperature	32°F ~ 104°F (0°C ~ 40°C)
Storage Temperature	-4°F ~ 140°F (-20°C ~ 60°C)
Operating Humidity	10% ~ 80%
Storage Humidity	10% ~ 80% @ 40°C, non-condensing
Vibration	0.5 Grms/ 5 ~ 500Hz/ operation (3.5" H.D.D) 1.5 Grms/ 5 ~ 500Hz/ no operation
Shock	10G peak acceleration (11 m sec. duration), operation 20G peak acceleration (11 m sec. duration), non-operation
Dimension (W X D X H)	16.93" x 18.7" x 1.73"(430mm x 475mm x 44mm)
I/O Interfaces	
Front Panel	Power LED x 1 Status LED x 1 HDD Active LED x 1 USB 3.2 Gen 1 Ports x 2 RJ-45 Console x 1 Parallel LCM display and 4 keypad x 1 Software Programmable Switch x 1
Rear Panel	AC Power Input x 1 Power Switch x 1 VGA port (Optional)

Dimension

Unit: mm

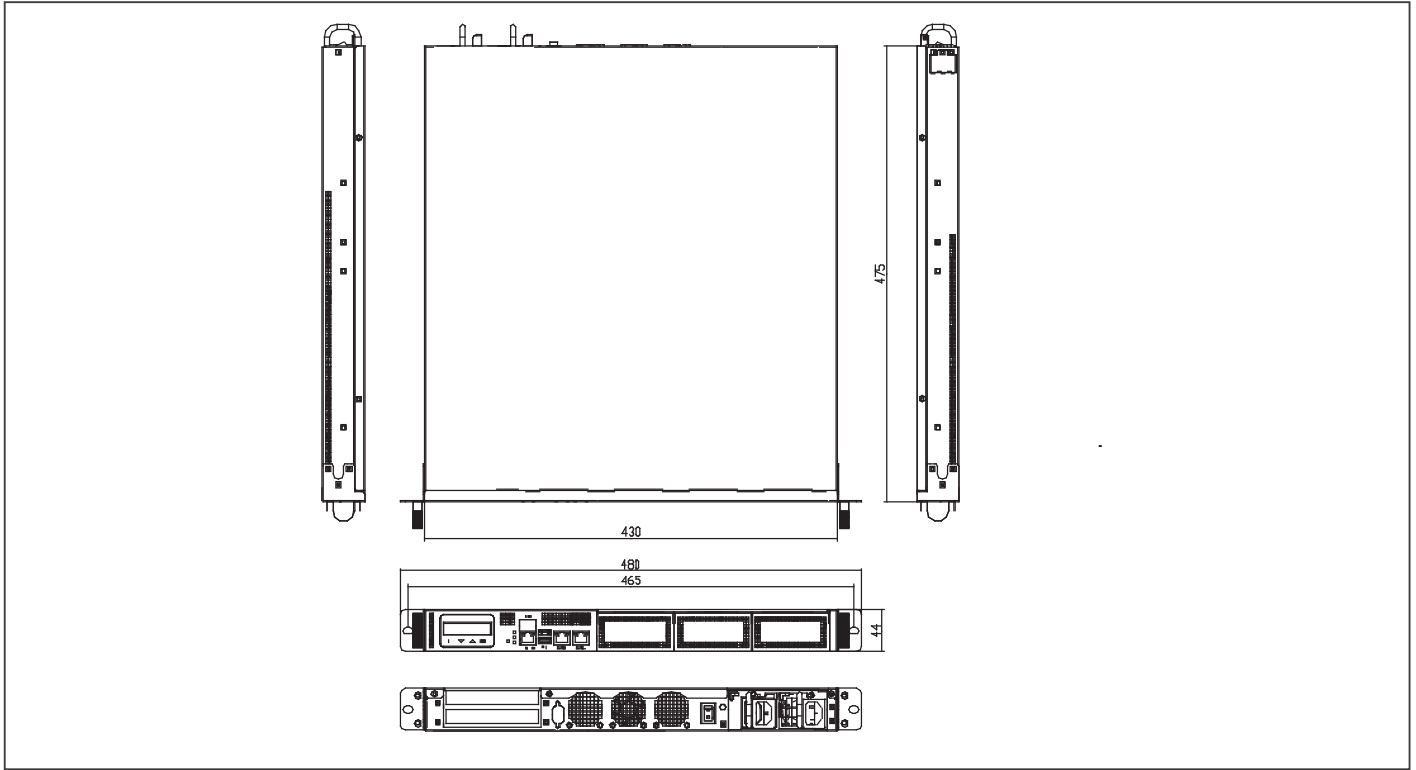

Ordering Information

Part Number	CPU	Memory	Mini-Card Slot	Storage	LAN	USB	Console	Bypass	NIM Slot	Expansion Slot	TPM	Display	Fan	Mounting	Power
FWS-7830W2-H22-A10-000	Intel® 8th Generation Core™/Xeon® Processors	DDR4 UDIMM x 4, Up to 64GB	—	2.5" HDD Bay x 2 + mSATA slot x1	Intel® I350 AM2 Gigabit Ethernet x 2	USB 3.2 Gen 1 x 2	RJ-45 console x 1	—	3 (Note 1)	1 (Note 2)	—	—	2	1U Rackmount	ATX

* Please contact AAEON for other optional specifications.

Note 1: Need to configure riser card and module

Note 2: Need to configure riser card

Packing List

- Console Cable
- Ear Brackets
- FWS-7830

Optional Accessories

- **M02666600**
Slide x 2, for Rackmount Usage
- **1702031803**
Power Cord, 3P-250V/10A, 180D, 1.8M, VDE, YP22/YP12
- **1702031802**
Power Cord, 3P-250V/10A, 180D, 1.8M, USA, YP22/YP12
- **170203180E**
Power Cord, 3P-25V/7A, 180D, 1.8M, PSE, YP12/YP12
- **9761781027**
VGA Cable
- **9761783000**
(TF)3.5x1 HDD Module, FWS-7830
- **9761783001**
(TF)2.5x2_HDD-LEFT Module, FWS-7830
- **NIM-S26C-A10-T40-0002**
Intel® Fortville XL710 PCI-Express 10G SFP+ 4 Ports Module for FWS-7820/7830
- **NIM-S26B-A10-F20-0002**
Intel® Fortville XL710 PCI-Express 40G QSFP 2 Ports Module for FWS-7820/7830
- **NIM-S13B-A10-G80-0002**
Intel® 82580EB PCI-Express 1G SFP 8 Ports Module for FWS-7820/7830
- **NIM-S13D-A10-G40-0002**
Intel® 82580EB PCI-Express 1G SFP 4 Ports Module for FWS-7820/7821/7830
- **NIM-C13B-A10-G82-0001**
Intel® 82580EB PCI-Express 1G Copper Ethernet 8 Ports Module for FWS-7820 w/ 2Pair bypass/7830
- **NIM-C13D-A10-G42-0002**
Intel® 82580EB PCI-Express 1G Copper Ethernet 4 Ports Module for FWS-7820 w/ 2Pair bypass/7830

FWS-7831

1U Rackmount Intel® 8th Generation Platform Network Appliance

Front View

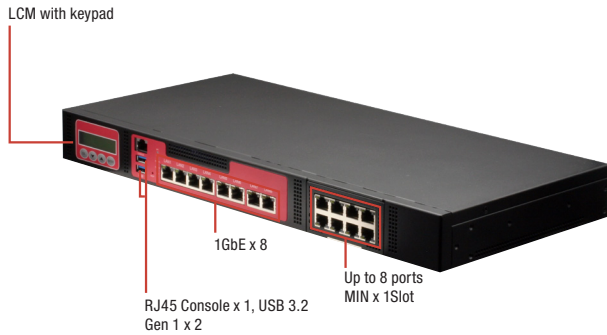

Rear View

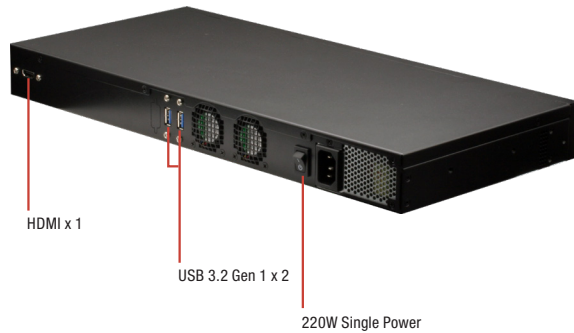

Specifications

System	
Form Factor	1U Rackmount Network Platform
Processor	Intel® Xeon® processor E-2100 family for Intel® C246 Chipset Intel® Core™/ Celeron® processor for Intel® H310 Chipset
Chipset	Intel®C246/H310
System Memory	DDR4 SODIMM x 2/ECC Up to 32GB DDR4 1600/1866/2133 SODIMM/ECC up to 32GB 260-pin DIMM x 2
Network	
Ethernet	Intel® i211 Gigabit Ethernet x 8 or Intel® i211 Gigabit Ethernet x 6 + SFP Ethernet ports x2 (C246) Intel® i211 Gigabit Ethernet x 6 (H310)
Bypass	2 Pairs
NIM Slot	Need to configure riser card

Features

- Single Intel® 8th Generation Core™/Xeon™ processor
- Intel® Coffee Lake 2/6 Core (H310/C246)
- 2 x DDR4 SO DIMM/ECC Up to 32GB
- TPM Supported (Optional Request)
- LCM with Keypad x 1
- RJ-45 Console x 1, USB 3.2 Gen 1 x 2, HDMI x1
- 220W ATX PSU
- Intel® i211 Gigabit Ethernet x 8 or Intel® i211 Gigabit Ethernet x 6 + SFP Ethernet ports x2
- Mini-Card (mSATA)



Display	
Graphic Controller	Intel® UHD Graphics 630
Connector	(HDMI x1 Optional)
Storage	
HDDs	Internal 2.5" HDD bay x 2 or (3.5" HDD bay x 1 can't use with NIM Optional)
CF/CFast/mSATA	mSATA
Internal/ Expansion Interface	
PCIe slot	—
Mini-PCIe slot	Mini-Card x 1 (PCIe[x1] + mSATA)
IPMI	—
Keyboard and Mouse	NA
USB	USB 3.2 Gen 1 x 2
Miscellaneous	
RTC	Internal RTC
Watchdog Timer	1~255 steps by software programmable
Software Button	GPIO Programmable push button x 1
TPM	(TPM2.0 9665/TPM v1.2 9660 optional)
GPIO	4 bits input, 4 bits output
FAN	2
MTBF (Hours)	362,825 Hours
Color	Black
Environmental Parameters and Dimension	
Power Requirement	220W ATX PSU
Operating Temperature	32°F ~ 104°F (0°C ~ 40°C)
Storage Temperature	-4°F ~ 140°F (-20°C ~ 60°C)
Operating Humidity	10%~80% relative humidity, non-condensing
Storage Humidity	10%~80% @40°C; non-condensing
Vibration	0.5 Grms/ 5 ~ 500Hz / operation (2.5" Hard Disk Drive) 1.5 Grms/ 5 ~ 500Hz / non operation
Shock	TBD
Dimension (W X D X H)	16.93" x 7.87" x 1.73"(430mm x 200mm x 44mm)
I/O Interfaces	
Front Panel	Power LED x 1, Status LED x 1, HDD Active LED x 1, USB 3.2 Gen 1 Ports x 2 - RJ-45 Console x 1
Rear Panel	AC Power Input x 1, Power Switch x 1, (Rear Expansion Slot x 1 Optional)

Dimension

Unit: mm

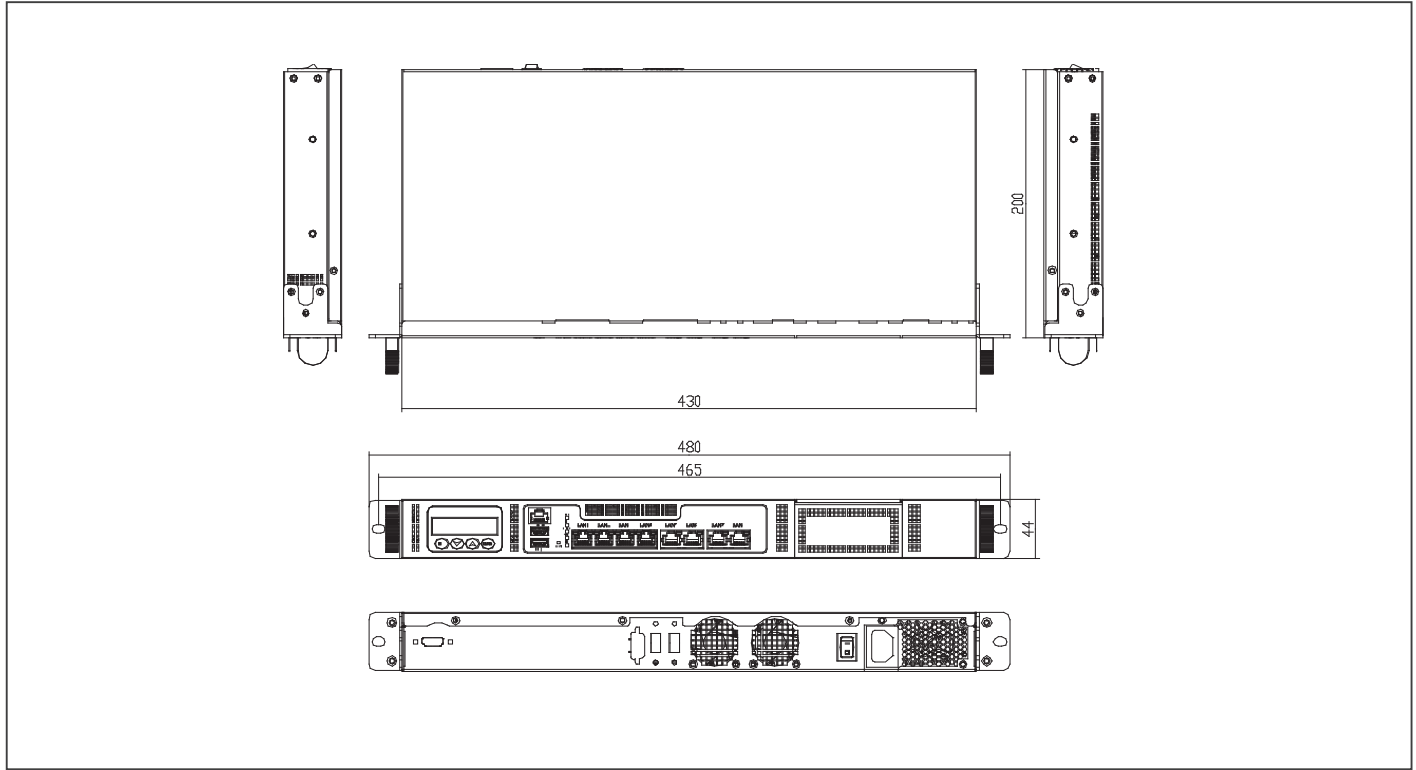

Ordering Information

Part Number	CPU	Memory	Mini-Card Slot	Storage	LAN	USB	Console	Bypass	NIM Slot*	Expansion Slot	TPM	Display	Fan	Mounting	Power
FWS-7831W8-H22-A10-000	Intel® 8th Generation Core™/ Xeon® Processors	2DDR4 S0 DIMM X2 / ECC Up to 32GB	Mini-Card x 1(Pcie[x1]+mSATA)	2.5" HDD Bay x 2	Intel® I211 Gigabit Ethernet x 8	USB 3.2 Gen 1 x 2	RJ-45 console x 1	2 Pairs	1 (Note)	—	—	—	2	1U Rackmount	ATX

* Note: Need to configure riser card and module
(Please contact AAEON for other optional specifications.)

Packing List

- Console Cable
- Ear Brackets
- FWS-7831

Optional Accessories

- **1702031803**
Power Cord, 3P-250V/10A, 180D, 1.8M, VDE, YP22/YP12
- **1702031802**
Power Cord, 3P-250V/10A, 180D, 1.8M, USA, YP22/YP12
- **170203180E**
Power Cord, 3P-25V/7A, 180D, 1.8M, PSE, YP12/YP12
- **9761783102**
HDMI Cable with screw
- **9761783000**
(TF)3.5x1 HDD Module, FWS-7830/7831
- **NIM-S26C-A10-T40-0002**
Intel® Fortville XL710 PCI-Express 10G SFP+ 4 Ports Module for FWS-7820/7830/7831
- **NIM-S26B-A10-F20-0002**
Intel® Fortville XL710 PCI-Express 40G QSFP 2 Ports Module for FWS-7820/7830/7831
- **NIM-S13B-A10-G80-0002**
Intel® 82580EB PCI-Express 1G SFP 8 Ports Module for FWS-7820/7830/7831
- **NIM-S13D-A10-G40-0002**
Intel® 82580EB PCI-Express 1G SFP 4 Ports Module for FWS-7820/7821/7830/7831
- **NIM-C13B-A10-G82-0001**
Intel® 82580EB PCI-Express 1G Copper Ethernet 8 Ports Module for FWS-7820 w/ 2Pair bypass/7830/7831
- **NIM-C13D-A10-G42-0002**
Intel® 82580EB PCI-Express 1G Copper Ethernet 4 Ports Module for FWS-7820 w/ 2Pair bypass/7830/7831
- **PER-R40X**
NIM LAN Module Riser Card

FWS-7820

1U Rackmount Network Appliance, Intel® C236 with 3 to 4 Network Interface Modules

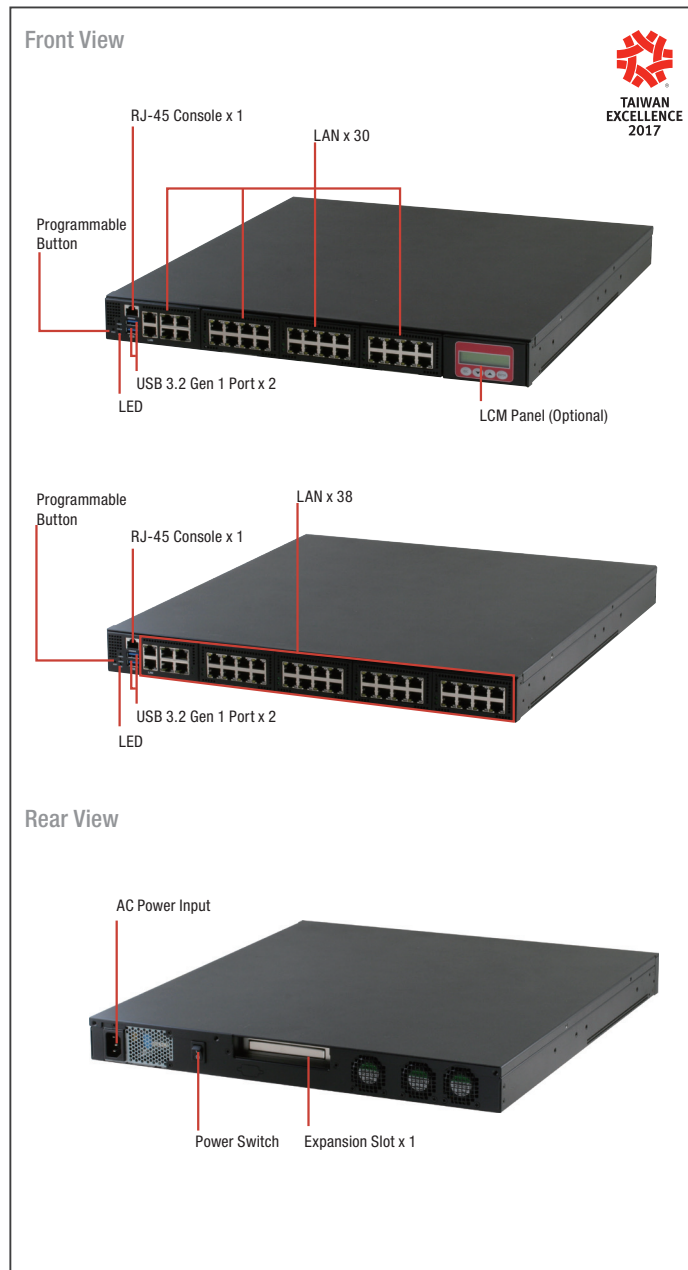

Features

- 1U Rackmount Network Appliance
- 6th Gen. Intel® LGA1151 Core™/ Xeon Processor
- 288-pin DDR4 1600/1866/2133 MHz ECC/U-DIMM x 4 Up to 64 GB
- Up to 10/100/1000Base-TX Ethernet Port x 38 (Depends on NIM)
- Up to 2 SATA 6 GB Ports (Internal 3.5" SATA HDD x 1 or 2.5" SATA HDD x 2) *mSATA/ CF/ CFast will be Disabled if 2nd SATA HDD is Used
- CF Socket x 1 (Can be Replaced by CFast™ Socket or mSATA Slot)
- LCM with Keypad x 1 (3 NIM Slots SKU)
- RJ-45 for Console x 1, USB 3.2 Gen 1 x 2
- 220W AC Type Power Input Requirement
- VGA Header x 1 (Optional VGA Cable)



Storage	
HDDs	Internal 3.5" SATA HDD x 1 or 2.5" SATA HDD x 2 (Optional)* *(mSATA/ CF/ CFast will be disabled if 2nd SATA HDD is used)
CF/CFast/mSATA	CF socket x 1 (Optional BOM CFast™ socket or mSATA slot)
Internal/ Expansion Interface	
PCIe slot	PCIe [x4] signal use [x8] slot (3rd NIM slot will be disabled if PCIe Riser supported)
Mini-PCIe slot	—
IPMI	—
Keyboard and Mouse	Pin-header
USB	USB 3.2 Gen 1 x 2, Box Header (2.0mm)
Miscellaneous	
RTC	Internal RTC
Watchdog Timer	1~255 steps by software programmable, 1 sec per step
Software Button	GPIO Programmable push button x 1
TPM	TPM2.0 9665 (TPM v1.2 9660 optional)
GPIO	8 bits, BIOS default 4 bits input, 4 bits output.
FAN	2
MTBF (Hours)	71,852
Color	Black
Environmental Parameters and Dimension	
Power Requirement	220W ATX PSU
Operating Temperature	32°F ~ 104°F (0°C ~ 40°C)
Storage Temperature	-4°F ~ 140°F (-20°C ~ 60°C)
Operating Humidity	10% ~ 80% relative humidity, non-condensing
Storage Humidity	10% ~ 80% @ 40°C, non-condensing
Vibration	0.5 Grms/ 5 ~ 500Hz/ operation (3.5" H.D.D) 1.5 Grms/ 5 ~ 500Hz/ no operation
Shock	10G peak acceleration (11 m sec. duration), operation 20G peak acceleration (11 m sec. duration), non-operation
Dimension (W X D X H)	16.93" x 18.7" x 1.73" (430mm x 475mm x 44mm)
I/O Interfaces	
Front Panel	Power LED x 1 Status LED x 1 HDD Active LED x 1 USB 3.2 Gen 1 Ports x 2 RJ-45 Console x 1 Parallel LCM display and 4 keypad x 1 (Optional w/ NIM slot) Software Programmable Switch x 1 Bypass LED x 2
Rear Panel	AC Power Input x 1 Power Switch x 1 VGA port (Optional) Rear Expansion Slot x 1 (Optional PCIe [x4] signal use [x8] slot, 3rd NIM slot will be disabled if PCIe Riser supported)

Specifications

System	
Form Factor	1U Rackmount Network Platform
Processor	6th Generation Intel® Core™/ Xeon® processors
Chipset	Intel® C236
System Memory	- DDR4 1600/1866/2133 UDIMM/ECC - Up to 64GB - 288-pin DIMM x 4
Network	
Ethernet	Intel® i210 GbE x 2, Intel® 82580 x4
Bypass	Onboard 2 pairs bypass, others depend on NIM module
NIM Slot	4 (Max. 5 slots by project base)
Display	
Graphic Controller	Intel® HD graphics integrated
Connector	VGA cable (Optional)

Dimension

Unit: mm

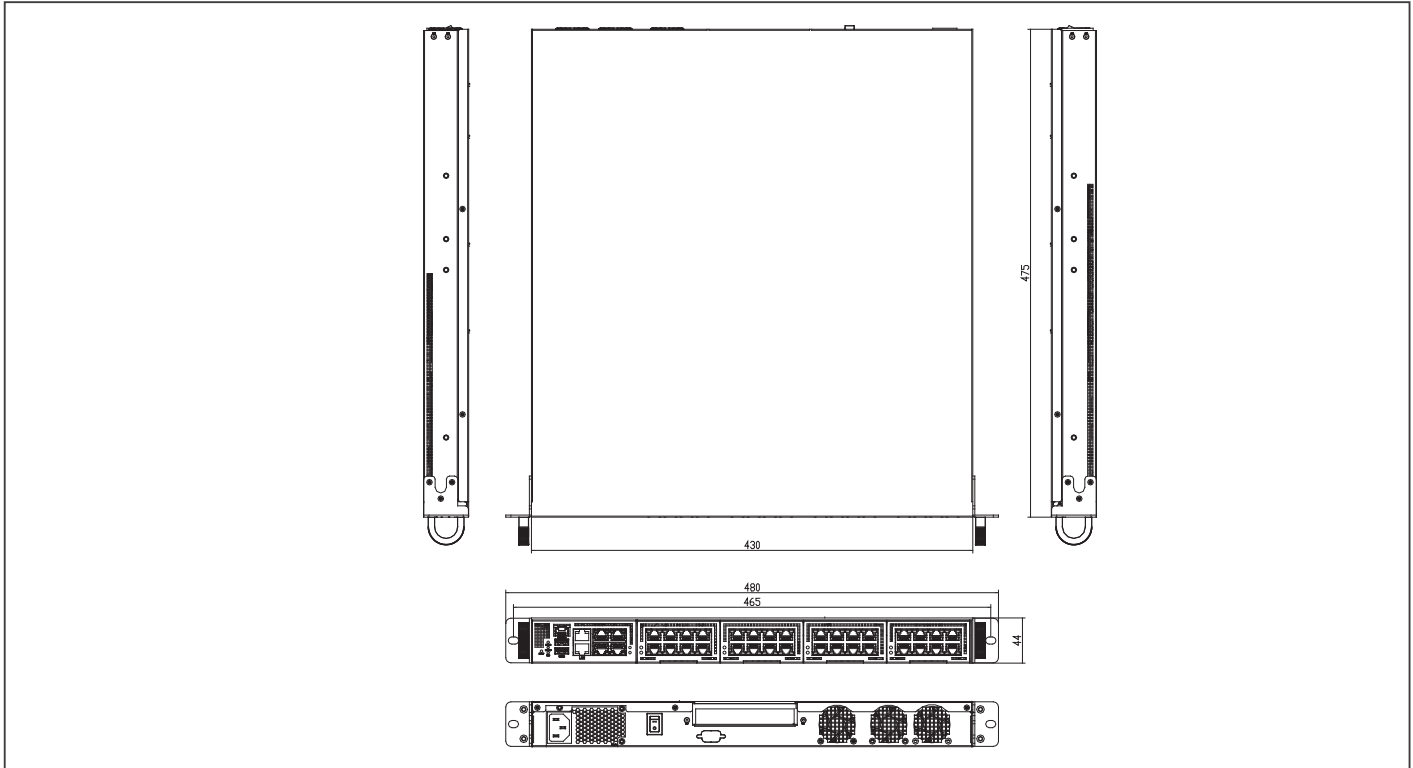

Ordering Information

Part Number	CPU	Memory	Storage	Display	LAN	USB	Console	Bypass	NIM Slot
FWS-7820W6-H25-A10-000	6th Generation Intel® Core/Xeon Processors	DDR4 ECC/UDIMM (Up to 64 GB)	3.5" HDD Bay x 1 + CF Card Slot	—	1 GbE x 6	USB 3.2 Gen 1 x 2	RJ-45 x 1	2	3

* Please contact AAEON for other optional specifications.

Packing List

- Console Cable
- Ear Brackets
- FWS-7820

Optional Accessories

- **M02666600**
Slide x 2, for Rackmount Usage
- **1702031803**
Power Cord, 3P-250V/10A, 180D, 1.8M, VDE, YP22/YP12
- **1702031802**
Power Cord, 3P-250V/10A, 180D, 1.8M, USA, YP22/YP12
- **170203180E**
Power Cord, 3P-25V/7A, 180D, 1.8M, PSE, YP12/YP12
- **9761781027**
VGA Cable
- **9761782008**
(TF)2.5" x 2 HDD Moudle, FWS-7820
- **9761782000**
(TF)3.5" x 1 HDD Moudle, FWS-7820
- **NIM-S26C-A10-T40-0002**
Intel® Fortville XL710 PCI-Express 10G SFP+ 4 Ports Module for FWS-7820
- **NIM-S26B-A10-F20-0002**
Intel® Fortville XL710 PCI-Express 40G QSFP 2 Ports Module for FWS-7820
- **NIM-S13B-A10-G80-0002**
Intel® 82580EB PCI-Express 1G SFP 8 Ports Module for FWS-7820
- **NIM-S13D-A10-G40-0002**
Intel® 82580EB PCI-Express 1G SFP 4 Ports Module for FWS-7820/7821
- **NIM-C13B-A10-G82-0001**
Intel® 82580EB PCI-Express 1G Copper Ethernet 8 Ports Module for FWS-7820 w/ 2Pair bypass
- **NIM-C13D-A10-G42-0002**
Intel® 82580EB PCI-Express 1G Copper Ethernet 4 Ports Module for FWS-7820 w/ 2Pair bypass

FWS-7821

Intel® C236 1U Rackmount 8 LANs with 1 NIM Slot Network Appliance

Front View

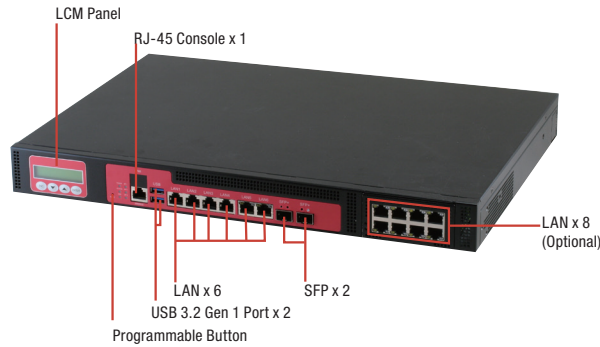

Rear View



Specifications

System	
Form Factor	1U Rackmount Network Platform
Processor	6th/7th Generation Intel® Core™/ Xeon® processors
Chipset	Intel® C236
System Memory	DDR4 1600/1866/2133/2400 UDIMM/ECC Up to 64GB 288-pin DIMM x 4
Network	
Ethernet	Intel® i211 GbE x 6 + Intel® i210 GbE x 2 (SFP) + NIM x 1 (Or i211 GbE x 8 + NIMx1) UDIMM/ECC
Bypass	Onboard 2 pairs bypass, others depend on NIM module
NIM Slot	1
Display	
Graphic Controller	Intel® HD graphics integrated
Connector	VGA cable (Optional)

Features

- 1U Rackmount Network Appliance
- Intel® LGA1151 6th/7th Generation Core™/Xeon Processors
- 288-pin ECC Dual Channel DDR4 2133 UDIMM x 4 Up to 64GB
- 10/100/1000Base-TX Ethernet Ports x 8 (Onboard RJ-45 x 6 & SFP x 2) with Max. 3 Pairs of LAN Bypass Function
- Internal 3.5" SATA HDD x 1 or 2.5" SATA HDD x 2 (Optional Extra 4 Pcs x 2.5" HDD without NIM and Expansion Lot Presented)
- CFast x 1 (Optional CF Socket or mSATA Slot)
- 8 bits GPIO (Default 4-bits Input, 4-bits Output)
- TPM Supported (Optional Request), RAID 0,1 Supported
- LCM with Keypad x 1, RJ-45 for Console x 1, USB 3.2 Gen 1 x 2
- 250W AC Type Power Input or 220W Single Power
- VGA Header x 1 (Optional VGA Cable)



Storage	
HDDs	Internal 2.5" SATA HDD x 2 or 3.5" SATA HDD x 1 (optional)
CF/CFast/mSATA	Optional BOM CFast™ socket or mSATA slot or CF™ socket (optional)
Internal/ Expansion Interface	
PCIe slot	Up to PCIe[x8] slot x 2
Mini-PCIe slot	Mini Card x 1
IPMI	—
Keyboard and Mouse	Pin-header
USB	USB 3.2 Gen 1 x 2, Box Header (2.0mm)
Miscellaneous	
RTC	Internal RTC
Watchdog Timer	1~255 steps by software programmable, 1 sec per step
Software Button	GPIO Programmable push button x 1
TPM	TPM v1.2 9660 (TPM2.0 9665 optional)
GPIO	4 bits input, 4 bits output
FAN	2
MTBF (Hours)	94,241
Color	Black
Environmental Parameters and Dimension	
Power Requirement	250W ATX PSU or 220W ATX PSU
Operating Temperature	32°F ~ 104°F (0°C ~ 40°C)
Storage Temperature	-4°F ~ 140°F (-20°C ~ 60°C)
Operating Humidity	10% ~ 80% relative humidity, non-condensing
Storage Humidity	10% ~ 80% @ 40°C, non-condensing
Vibration	0.5 Grms/ 5 ~ 500Hz/ operation (3.5" H.D.D) 1.5 Grms/ 5 ~ 500Hz/ no operation
Shock	10G peak acceleration (11 m sec. duration), operation 20G peak acceleration (11 m sec. duration), non-operation
Dimension (W X D X H)	16.93" x 12.01" x 1.73" (430mm x 305mm x 44mm)
I/O Interfaces	
Front Panel	Power LED x 1 Status LED x 1 HDD Active LED x 1 USB 3.2 Gen 1 Ports x 2 RJ-45 Console x 1 Parallel LCM display and 4 keypad x 1 (Optional w/ NIM slot) Software Programmable Switch x 1 Bypass LED X2 RJ45 X8 or RJ45 X6+SFPX 2
Rear Panel	AC Power Input x 1 Power Switch x 1 VGA port (Optional) Rear Expansion Slot x 2 (2 x PCIe [x8] slots, NIM slot will be disabled if PCIe Riser supported)

Dimension

Unit: mm

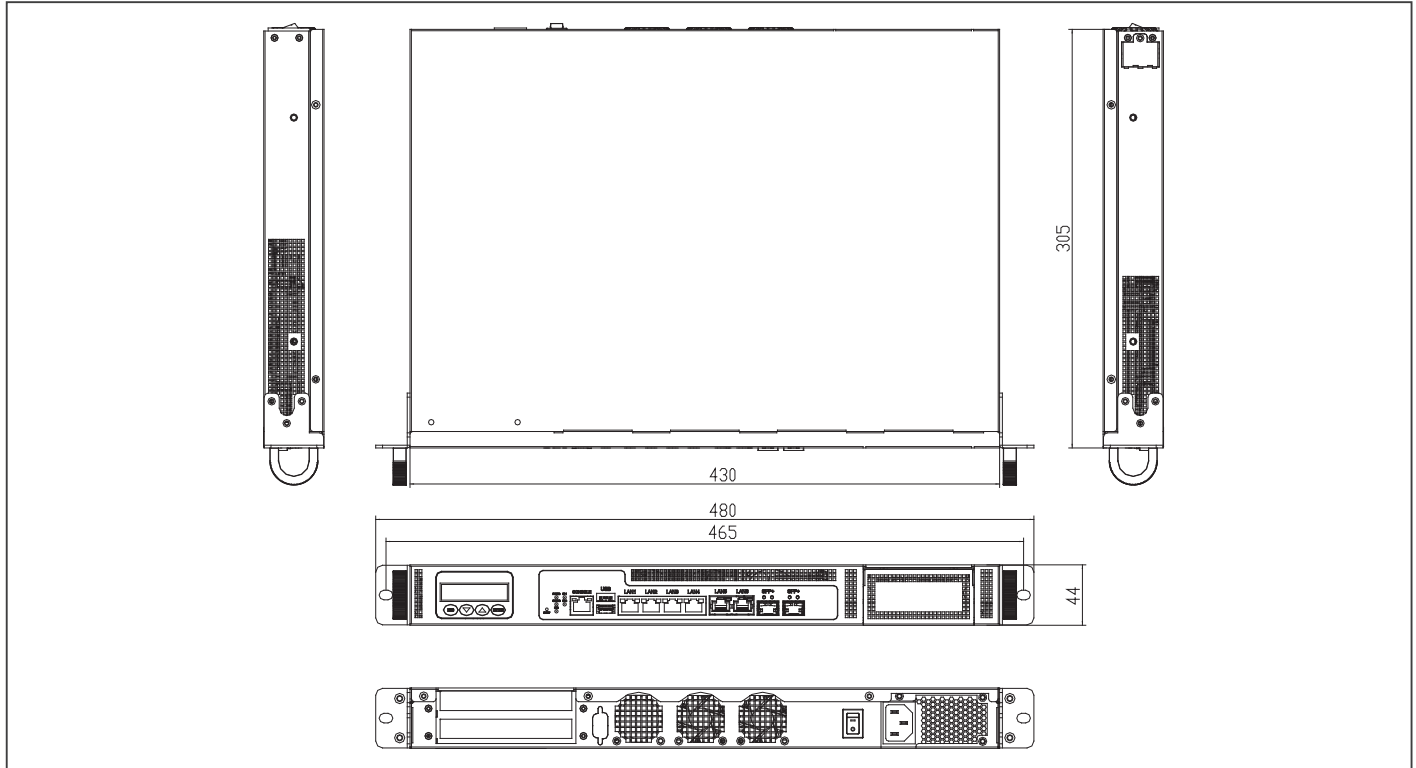

Ordering Information

Part Number	CPU	Memory	Storage	Display	LAN	USB	Console	Bypass	*NIM Slot	*Expansion Slot
FWS-7821W8-H25-A10-000	6th/7th Gen. Intel® Core™/Xeon	DDR4 ECC/UDIMM (Up to 64 GB)	2.5" HDD Bay x 2 + CFast™ Slot x 1	—	1 GbE x 6, 2 x 1G SFP	USB 3.2 Gen 1 x 2	RJ-45 x 1	2	1 (Note 1)	2 (Note 2)

* Please contact AAEON for other optional specifications.

Note 1: Need to configure riser card and module

Note 2: Need to configure riser card

Packing List

- Console Cable
- Ear Brackets
- FWS-7821

Optional Accessories

- **M02666600**
Slide x 2, for Rackmount Usage
- **1702031803**
Power Cord, 3P-250V/10A, 180D, 1.8M, VDE, YP22/YP12
- **1702031802**
Power Cord, 3P-250V/10A, 180D, 1.8M, USA, YP22/YP12
- **170203180E**
Power Cord, 3P-25V/7A, 180D, 1.8M, PSE, YP12/YP12
- **9761781027**
VGA Cable
- **9761782100**
(TF)2.5" x 2 HDD-LEFT Module, FWS-7821
- **PER-R40X**
NIM LAN Module Riser Card
- **PER-R44X**
2 Slot Rear PCIe Riser Card
- **PER-T354**
1 Slot Rear PCIe Riser Card
- **NIM-S26C-A10-T40-0002**
Intel® Fortville XL710 PCI-Express 10G SFP+ 4 Ports Module for FWS-7821
- **NIM-S26B-A10-F20-0002**
Intel® Fortville XL710 PCI-Express 40G QSFP 2 Ports Module for FWS-7821
- **NIM-S13B-A10-G80-0002**
Intel® 82580EB PCI-Express 1G SFP 8 Ports Module for FWS-7820
- **NIM-S13D-A10-G40-0002**
Intel® 82580EB PCI-Express 1G SFP 4 Ports Module for FWS-7820/7821
- **NIM-C13B-A10-G82-0001**
Intel® 82580EB PCI-Express 1G Copper Ethernet 8 Ports Module for FWS-7821 w/ 2Pair bypass
- **NIM-C13D-A10-G42-0002**
Intel® 82580EB PCI-Express 1G Copper Ethernet 4 Ports Module for FWS-7821 w/ 2Pair bypass
- **NIM-S13E-A10-G42-0001**
LAN Module, Intel® 82580EB, 4 x 1GSFP, 2 Bypass, SX short wave, REV. A1.0
- **NIM-S13E-A10-G42-0002**
LAN Module, Intel® 82580EB, 4 x 1GSFP, 2 Bypass, LX long wave, REV. A1.0

FWS-7360

1U Rackmount 7 LAN Network Appliance with Intel® Atom™ C3758 Processor SoC

Front View

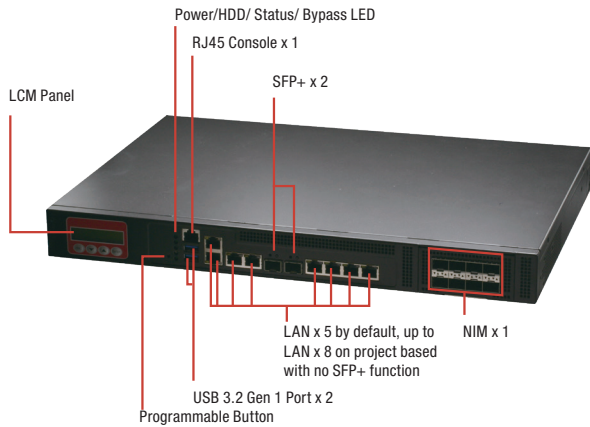

Rear View



Specifications

System	
Form Factor	1U Rackmount Network Platform
Processor	Intel® C3758 processor SoC, optional support up to 16 core
Chipset	SoC
System Memory	DDR4 Slot x 4, Support ECC UDIMM/RDIMM upto 256GB
Network	
Ethernet	Intel®X553 RJ45 x 2, Intel® i211 GbE x 3, SFP+ x 2 from CPU
Bypass	Onboard 2 pairs bypass, others depend on NIM module
NIM Slot	1
Display	
Graphic Controller	—
Connector	—
Storage	
HDD	2.5" HDD Bay x 2
CF/CFast/msATA	Default SATA III port x 2 (MSATA Slot X 2 Optional)

Features

- Intel® Atom™ C3758 SoC Processor, Optional Support up to 16 Core
- DDR4 Slot x 4, Support ECC UDIMM/RDIMM upto 256GB
- 5 Copper (2 From 88E1543/ 3 From Intel® I211)
- 2 10Gb SFP+ (From CPU)
- Onboard 2 Pairs Bypass
- Mini-Card Socket (Full-Size) x 1, Mini-Card Socket (Full-Size) with SIM Socket x 1 (Optional)
- Internal 2.5" SATA HDD x 2
- LCM with Keypad x 1, RJ-45 Console x 1, USB 3.2 Gen 1 x 2
- 100W Flex ATX PSU 150W
- TPM (Optional)



Internal/ Expansion Interface

PCIe Slot	PCIe [x8] slot x 1, cannot use w/ NIM
Mini-PCIe Slot	Default Mini-Card socket (full-size) x1 (Mini-Card socket (full-size) with SIM socket x 1 Optional)
IPMI	—
Keyboard and Mouse	—
USB	USB 3.2 Gen 1 x 2

Miscellaneous

RTC	Internal RTC
Watchdog Timer	1~255 steps by software programmable
Software Button	GPIO Programmable Button x 1
TPM	Optional TPM v1.2 / TPM v2.0
GPIO	4 bits input, 4bits output
Fan	System Fan x 1
MTBF (Hours)	142,412
Color	Black

Environmental Parameters and Dimension

Power Requirement	150W Flex ATX PSU
Operating Temperature	32°F ~ 104°F (0°C ~ 40°C)
Storage Temperature	-4°F ~ 140°F (-20°C ~ 60°C)
Operating Humidity	10%~80% relative humidity, non-condensing
Storage Humidity	10%~80% @40°C; non-condensing
Vibration	0.5 Grms/ 5 ~ 500Hz / operation (2.5" HDD) 1.5 Grms/ 5 ~ 500Hz / non operation
Shock	10 G peak acceleration (11 m sec. duration), operation 20 G peak acceleration (11 m sec. duration), non operation
Dimension (W X D X H)	16.93" x 12.01" x 1.73" (430mm x 305mm x 44mm)

I/O

Front Panel	SFP+ with LED x 2 RJ45 Ethernet Port with LED x 5 USB 3.2 Gen 1 x 2 RJ45 Console x 1 Software Programmable Button x 1 Parallel LCM Display and 4 Keypad x 1 LED for Power/HDD/ Status/ Bypass x 5 NIM Slot x 1 Bypass LED x 2 Power LED x1 HDD LED x1 Status LED x1
Rear Panel	Power Switch x 1 AC Power Input x 1 Rear Expansion Slot x 1

Dimension

Unit: mm

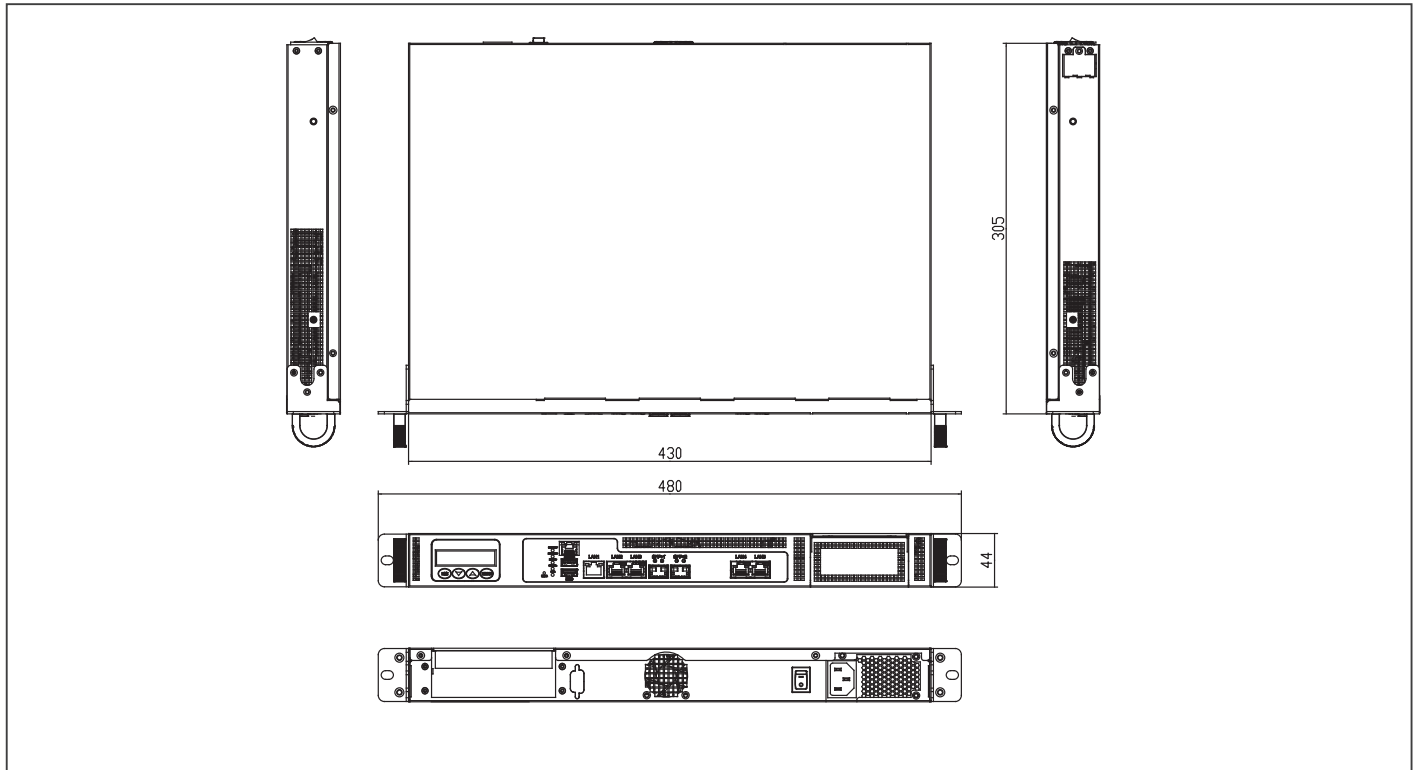

Ordering Information

Part Number	CPU	Memory	Mini-Card Slot	Storage	LAN	USB	Console	Bypass	NIM Slot	Expansion Slot	TPM	Display
FWS-7360E7-A10-000	Intel® Atom® C3758	DDR4 UDIMM/ECC slot x 4	Full Size x 1 (PCIe + USB)	2.5" HDD Bay x 2	RJ45 x 5, SFP+ x 2	USB 3.2 Gen 1 x 2	RJ-45 x 1	2 pairs onboard	1 (Note 1)	1 (Note 2)	—	—

* Please contact AAEON for other optional specifications.

Note 1: Need to configure riser card and module

Note 2: Need to configure riser card

Note 3: NIM and expansion slot cannot be used at the same time

Packing List

- Console Cable
- Ear Brackets
- FWS-7360

Optional Accessories

- **M02666600**
Slide x 2, for Rackmount Usage
- **1702031803**
Power Cord, 3P-250V/10A, 180D, 1.8M, VDE, YP22/YP12
- **1702031802**
Power Cord, 3P-250V/10A, 180D, 1.8M, USA, YP22/YP12
- **170203180E**
Power Cord, 3P-25V/7A, 180D, 1.8M, PSE, YP12/YP12
- **PER-R40X**
NIM LAN Module Riser Card
- **NIM-S26C-A10-T40-0002**
Intel® Fortville XL710 PCI-Express 10G SFP+ 4 Ports Module for FWS-7821
- **NIM-S26B-A10-F20-0002**
Intel® Fortville XL710 PCI-Express 40G QSFP 2 Ports Module for FWS-7821
- **NIM-S13B-A10-G80-0002**
Intel® 82580EB PCI-Express 1G SFP 8 Ports Module for FWS-7820
- **NIM-S13D-A10-G40-0002**
Intel® 82580EB PCI-Express 1G SFP 4 Ports Module for FWS-7820/7821
- **NIM-C13B-A10-G82-0001**
Intel® 82580EB PCI-Express 1G Copper Ethernet 8 Ports Module for FWS-7821 w/ 2Pair bypass
- **NIM-C13D-A10-G42-0002**
Intel® 82580EB PCI-Express 1G Copper Ethernet 4 Ports Module for FWS-7821 w/ 2Pair bypass
- **NIM-S13E-A10-G42-0001**
LAN Module, Intel® 82580EB, 4 x 1GSFP, 2 Bypass, SX short wave, REV. A1.0
- **NIM-S13E-A10-G42-0002**
LAN Module, Intel® 82580EB, 4 x 1GSFP, 2 Bypass, LX long wave, REV. A1.0

NIM-S13B

Intel® 82580EB (i350-AM4; Optional by request) PCI-Express 1G SFP 8 Ports Module

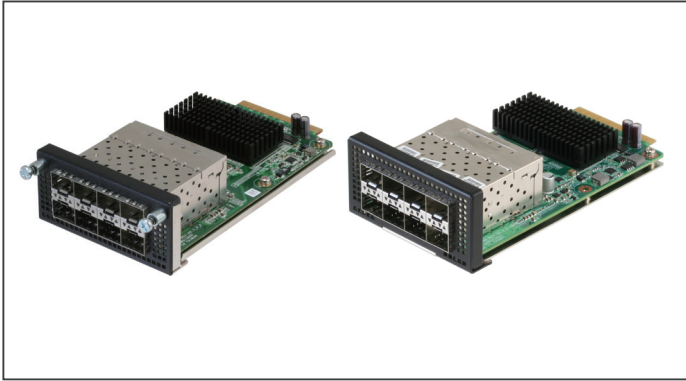

Specifications

Main Specification	
Form Factor	1G Fiber Module
Main Chipset	Intel® 82580EB (i350-AM4; Optional by request) Ethernet Controller x 2
Bypass	—
Host Interface	PCI-Express [x4]
LAN Port	SFP 1GbE Connector x 8
Indicator	LED x 8 for Active/Link
Qualification	CE/FCC Class A
Operation Temp.	32°F ~ 104°F (0°C ~ 40°C)
Dimension	5.71" x 3.03" (145mm x 77mm)

Features

- PCI-Express Host Interface



Network Appliance Options

- FWS-7360
- FWS-7830
- FWS-7831
- FWS-7821
- FWS-7820
- FWS-7840
- FWS-8600

Ordering Information

- NIM-S13B-A10-G80-0002
Intel® 82580EB PCI-Express 1G SFP 8 Ports Module for FWS-7820/7821/7830/7831/8600/7360

NIM-S13D

Intel® 82580EB (i350-AM4; Optional by request) PCI-Express 1G SFP 4 Ports Module

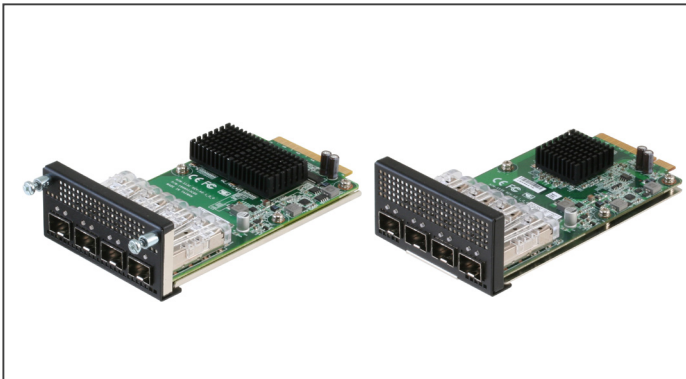

Specifications

Main Specification	
Form Factor	1G Fiber Module
Main Chipset	Intel® 82580EB (i350-AM4; Optional by request) Ethernet Controller x 1
Bypass	—
Host Interface	PCI-Express [x4]
LAN Port	SFP 1GbE Connector x 4
Indicator	LED x 4 for Active/Link
Qualification	CE/FCC Class A
Operation Temp.	32°F ~ 104°F (0°C ~ 40°C)
Dimension	5.71" x 3.03" (145mm x 77mm)

Features

- PCI-Express Host Interface



Network Appliance Options

- FWS-7360
- FWS-7830
- FWS-7831
- FWS-7821
- FWS-7820
- FWS-7840
- FWS-8600

Ordering Information

- NIM-S13D-A10-G40-0002
Intel® 82580EB PCI-Express 1G SFP 4 Ports Module for FWS-7820/7821/7830/7831/8600/7360

NIM-S13E

Intel® 82580EB (i350-AM4; Optional by request) PCI-Express 1G Fiber Ethernet 4 Ports Module

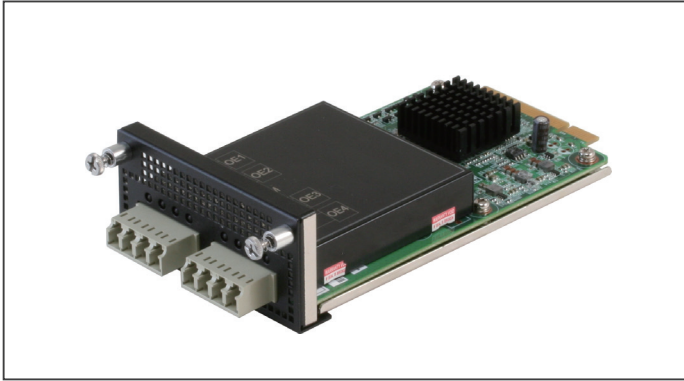

Features

- PCI-Express Host Interface



Network Appliance Options

- FWS-7360
- FWS-7830
- FWS-7831
- FWS-7821
- FWS-7820
- FWS-7840
- FWS-8600

Specifications

Main Specification	
Form Factor	1G Fiber Module
Main Chipset	Intel® 82580EB (i350-AM4; Optional by request) Ethernet Controller x 1
Bypass	2
Host Interface	PCI-Express [x4]
LAN Port	SFP 1GbE Connector x 4
Indicator	LED x 4 for Active/Link
Qualification	CE/FCC Class A
Operation Temp.	32°F ~ 104°F (0°C ~ 40°C)
Dimension	5.71" x 3.03" (145mm x 77mm)

Ordering Information

- NIM-S13E-A10-G42-0001
LAN Module, Intel® 82580EB, 4 x 1GSFP, 2 Bypass, SX short wave, REV. A1.0
- NIM-S13E-A10-G42-0002
LAN Module, Intel® 82580EB, 4 x 1GSFP, 2 Bypass, LX long wave, REV. A1.0

NIM-C13B

Intel® 82580EB (i350-AM4; Optional by request) PCI-Express 1G Copper Ethernet 8 Ports Module

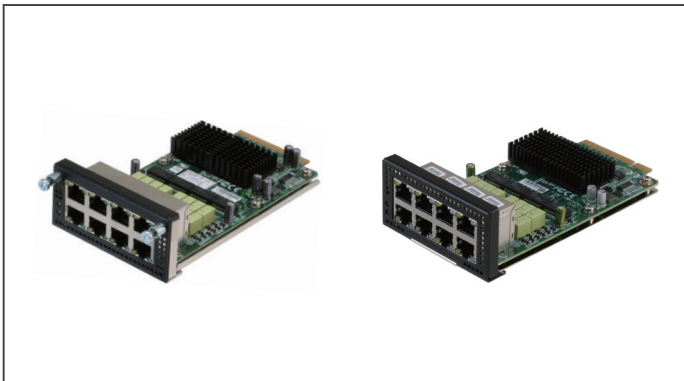

Features

- PCI-Express Host Interface



Network Appliance Options

- FWS-7360
- FWS-7830
- FWS-7831
- FWS-7821
- FWS-7820
- FWS-7840
- FWS-8600

Ordering Information

- NIM-C13B-A10-G82-0001
Intel® 82580EB PCI-Express 1G Copper Ethernet 8 Ports Module for FWS-7820/7821/7830/7831/7360/8600 w/ 2Pair bypass

Specifications

Main Specification	
Form Factor	1G LAN Module
Main Chipset	Intel® 82580EB (i350-AM4; Optional by request) Ethernet Controller x 2
Bypass	—
Host Interface	PCI-Express [x8] (x4 + x4)
LAN Port	1GbE Connector x 8
Indicator	LED x 8 for Active/Link
Qualification	CE/FCC Class A
Operation Temp.	32°F ~ 104°F (0°C ~ 40°C)
Dimension	5.71" x 3.03" (145mm x 77mm)

NIM-C13D

Intel® 82580EB (i350-AM4; Optional by request) PCI-Express 1G Copper Ethernet 4 Ports Module



Specifications

Main Specification	
Form Factor	1G Copper Module
Main Chipset	Intel® 82580EB (i350-AM4; Optional by request) Ethernet Controller x 1
Bypass	2
Host Interface	PCI-Express [x4]
LAN Port	1GbE Connector x 4
Indicator	LED x 4 for Active/Link
Qualification	CE/FCC Class A
Operation Temp.	32°F ~ 104°F (0°C ~ 40°C)
Dimension	5.71" x 3.03" (145mm x 77mm)

Features

- PCI-Express Host Interface



Network Appliance Options

- FWS-7360
- FWS-7830
- FWS-7831
- FWS-7821
- FWS-7820
- FWS-7840
- FWS-8600

Ordering Information

• NIM-C13D-A10-G42-0002

Intel® 82580EB PCI-Express 1G Copper Ethernet 4 Ports Module for FWS-7820/7821/7830/7831/7360/8600 w/ 2Pair bypass

NIM-S26B

Intel® XL710 PCI-Express 40G QSFP 2 Ports Module

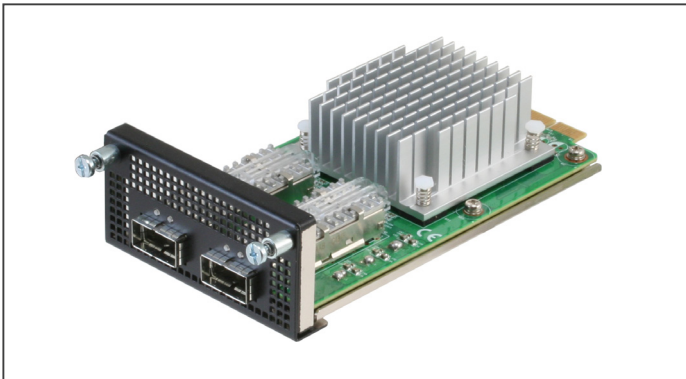

Specifications

Main Specification	
Form Factor	40G Fiber Module
Main Chipset	Intel® Fortville XL710 Ethernet Controller x 1
Bypass	—
Host Interface	PCI-Express [x8]
LAN Port	QSFP 40GbE Connector x 2
Indicator	LED x 2 for Active/Link
Qualification	CE/FCC Class A
Operation Temp.	32°F ~ 104°F (0°C ~ 40°C)
Dimension	5.71" x 3.03" (145mm x 77mm)

Features

- PCI-Express Host Interface
- 40 GbE QSFP Fiber Port x 2



Network Appliance Options

- FWS-7360
- FWS-7830
- FWS-7831
- FWS-7821
- FWS-7820
- FWS-7840
- FWS-8600

Ordering Information

• NIM-S26B-A10-F20-0002

Intel® XL710 PCI Express 40GbE QSFP 2 Ports Module for FWS-7820/7821/7830/7831/7360/8600

NIM-S26C

Intel® XL710 PCI-Express 10G SFP+ 4 Ports Module

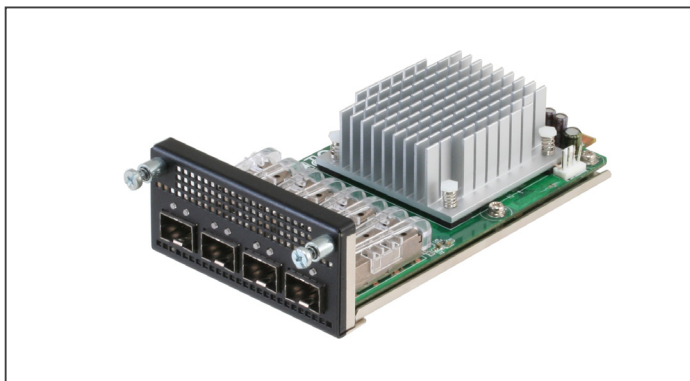

Features

- PCI-Express Host Interfaces
- 10G SFP+ Fiber Port x 4



Network Appliance Options

- FWS-7360
- FWS-7830
- FWS-7831
- FWS-7821
- FWS-7820
- FWS-7840
- FWS-8600

Specifications

Main Specification	
Form Factor	10G Fiber Module
Main Chipset	Intel® XL710 Ethernet Controller x 1
Bypass	—
Host Interface	PCI-Express [x8]
LAN Port	SFP+ 10 GbE Connector x 4
Indicator	LED x 4 for Active/Link
Qualification	CE/FCC Class A
Operation Temp.	32°F ~ 104°F (0°C ~ 40°C)
Dimension	5.71" x 3.03" (145mm x 77mm)

Ordering Information

- **NIM-S26C-A10-T40-0002**
LAN Module, Intel® XL710, 10 GbE SFP+ x 4, FWS-7820/7821/7830/7831/7360/8600, Rev. A.1.0

NIM-S26D

Intel® Ethernet Controller XL710-BM1 (Fortville) Quad Port SFP+ 10 GbE LAN Module

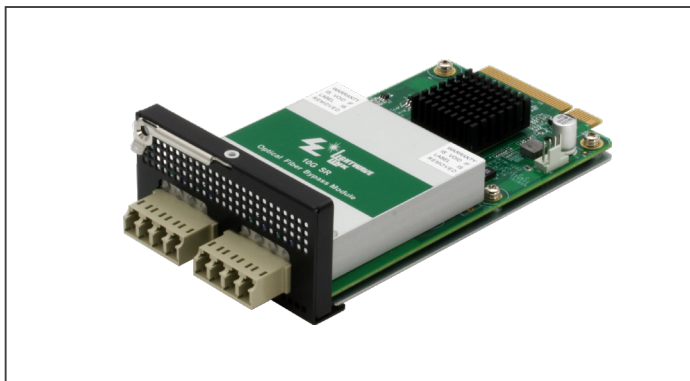

Features

- PCI-Express Gen3 [x8] Host Interfaces
- Intel® Ethernet Controller XL710-BM1
- 10G SFP+ Fiber ports x 4+SR
- Two pairs Bypass function



Network Appliance Options

- FWS-7820
- FWS-7821
- FWS-7831
- FWS-7830
- FWS-7840
- FWS-8600

Ordering Information

- **NIM-S26D-A10-T42-0002**
LAN Module, Intel XL710.4 x 10GbE SFP+ 2 x BP.SR, FWS-7820/7821/7830/8600

Specifications

Main Specification	
Form Factor	10GbE Fiber LAN Module
Main Chipset	Intel® XL710-BM1 Ethernet Controller x 1
Bypass	2
Host Interface	PCI-Express [x8]
LAN Port	SFP+ 10 GbE Connector x 4 SR
Indicator	LED x 4 for Active/Link
Qualification	CE/FCC Class A
Operation Temp.	32°F ~ 104°F (0°C ~ 40°C)
Dimension	5.71" x 3.03" (145mm x 77mm)

03

► Industrial Network Appliances



03

ICS-6270

DIN Rail 6 LAN Ports Industrial-Grade Network Appliance with Intel® Celeron® N3350 Processor SoC

Front View

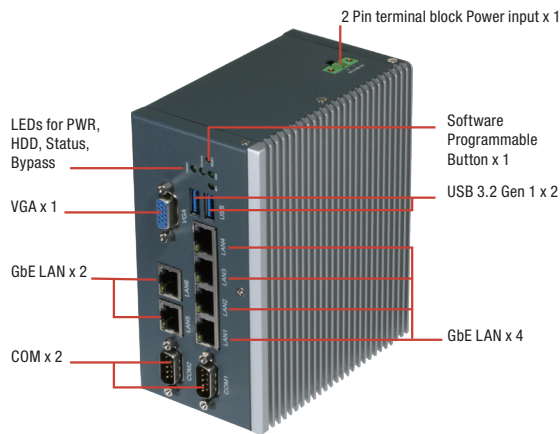

Rear View



Features

- Intel® Celeron® Processor N3350 SoC
- 204-pin Dual Channel DDR3L 1866 MHz SODIMM x 1 up to 8GB
- 10/100/1000Base-TX Ethernet Port x 6 (Supports up to 2 Pairs bypass)
- Supports up to Mini-Card Socket with SIM Socket x 1
- +9 – 36V DC Power Input Terminal Block
- Supports up to RS-232/422/485 COM Port x 2 with ESD Protection
- -40°C~75°C Operating Temp.



System Fan	Fanless
Color	Dark Grey
Power Supply	2 Pin Terminal Block
Dimension	4.96" x 2.93" x 5.74" (126 x 74.5 x 146mm)
Power Requirement	+9 ~ 36V, 2-pin terminal block
MTBF (Hours)	101,292
Display	
Chipset	Intel® HD Graphics 500
Interface	VGA port x 1
I/O	
Front I/O Panel	RJ-45 GbE x 6 RS-232/422/485 COM Port x 2 VGA port x 1 USB 3.2 Gen 1 x 2 Software programmable button x 1 Power LED x 1 HDD LED x 1 Status LED x 1 Bypass LED x 2
Rear I/O Panel	DIN Rail/ Wallmount Lock
Top Panel	2-Pin Terminal Block +9~36VDC x 1
Environmental Parameters and Dimension	
Operating Temperature	-40°F ~ 156°F (-40°C ~ 75°C)
Storage Temperature	-40°F ~ 185°F (-40°C ~ 85°C)
Operating Humidity	10% ~ 80% relative humidity, non-condensing
Storage Humidity	10% ~ 80% @40°C; non-condensing
Vibration	0.5 Grms/ 5 ~ 500Hz / operation (SSD) 1.5 Grms/ 5 ~ 500Hz / non operation
Shock	10 G peak acceleration (11 m sec. duration), operation 20 G peak acceleration (11 m sec. duration), non operation

Specifications

System	
Form Factor	DIN Rail/ Desktop
Processor	Intel® Celeron® Processor N3350 SoC
System Memory	204-pin DDR3L 1866MHz x 1, SODIMM Up to 8GB
Chipset	—
Ethernet	Intel® i211, Gigabit Ethernet x 6
Bypass	Supports up to 2 pairs
BIOS	AMI SPI Flash BIOS
Serial ATA	SATA 6.0 Gb/s port x 1, for 2.5" HDD/SSD
CFast/mSATA	CFast™ socket x 1 (co-lay mSATA)
Expansion Interface	Supports Mini-Card slot x 1 with SIM socket
USB	USB 3.2 Gen 1 x 2
Serial Port	Supports up to RS-232/422/485 COM Port x 2
Watchdog Timer	1~255 steps by software programmable
RTC	Internal RTC

Dimension

Unit: mm

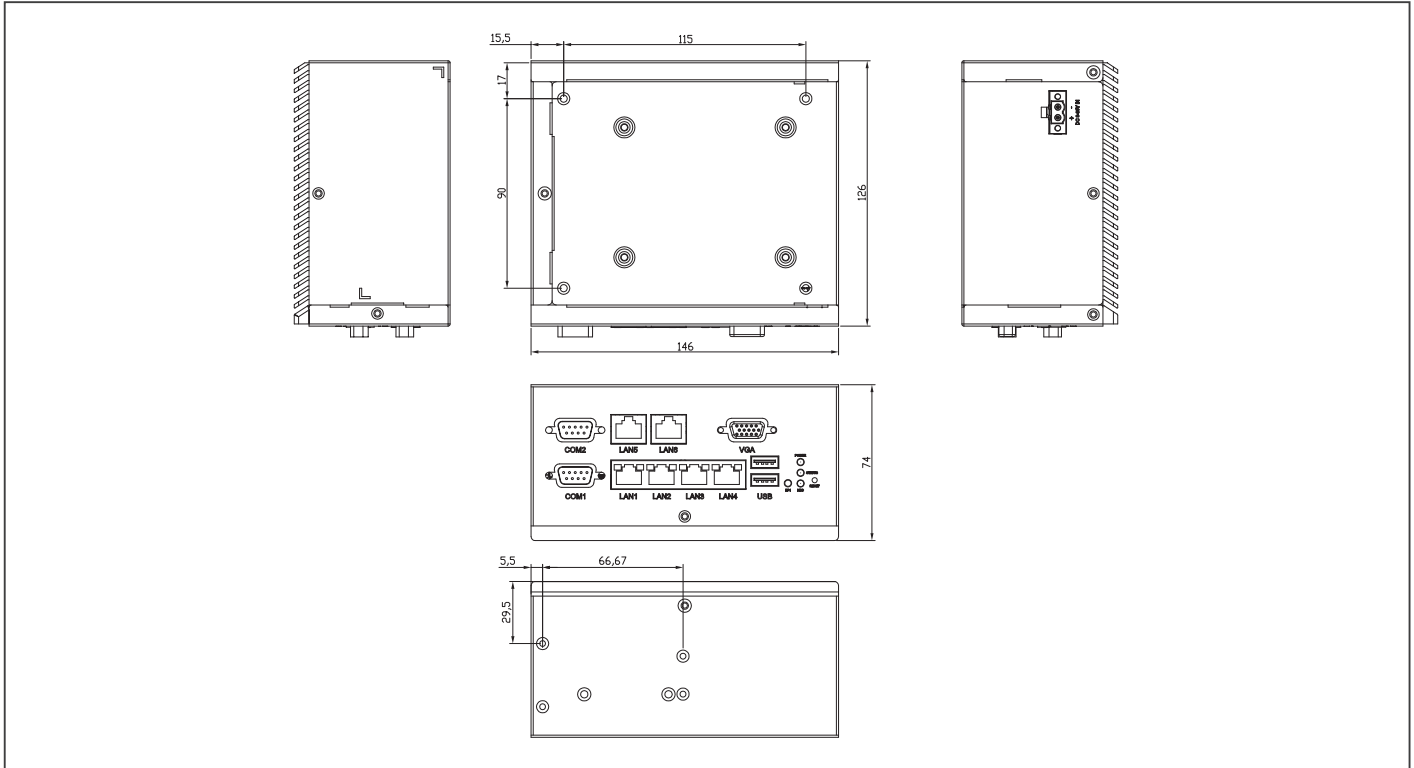

Ordering Information

Part Number	CPU	Memory	Bypass	Mini-Card Slot	Storage	LAN	USB	RS-232/422/485	System Fan	TPM	Display	Mounting	Power
ICS-6270A-A10-00	Intel® Celeron® N3350	204-pin DDR3L SODIMM socket x 1	1 Pair	Full Size and SIM socket x 1	CFast socket x 1 SATA 6.0 Gb/s port x 1	6	USB 3.2 Gen 1 x 2	COM x 2 COM2 with isolation	1	Optional, default N/A	VGA x 1	DIN Rail	+9~36V DC In

Packing List

- 2 Pin Phoenix Contact Connector (Male)
- SATA Cable x 1
- SATA Power Cable x 1
- DIN Rail Kit x 1
- ICS-6270

Optional Accessories

- **9761627020**
Wallmount Kit (No Packing)
- **1255300407**
2 Pin Phoenix Contact 40W Power Adapter

ICS-6280 PRELIMINARY

DIN Rail 4 LAN Ports Industrial-Grade Network Appliance with Intel® Elkhart Lake Platform

Front View



Rear View



Features

- Intel® Elkhart Lake SoC
- 10/100/1000Base-TX Ethernet x 4
- Supports 1 Pair Bypass (Optional 2 pairs)
- 204-pin DDR4 2133/2400MHz with IBECC support
- Support mini-card socket x 1, Micro SIM socket x 1
- 9~48Vdc power redundancy input with terminal block x 2
- 2.5" SATA SSD x 1 support
- Support upto RS-232/422/485 COM ports x 2 (COM2 with isolation) with ESD Protection
- HDMI port x 1, USB 3.2 ports x 2, VGA port x 1
- Wide-Temp -40°C ~ 75°C Fanless Solution



System Fan	Fanless
Color	Black
Power Supply	Dual 2-Pin Phoenix terminal block
Dimension	5.12" x 4.96" x 2.83" (130mm x 126mm x 72mm)
Power Requirement	Redundant 9~48Vdc power input
MTBF (Hours)	TBD
Display	
Chipset	Intel® HD Graphics
Interface	HDMI port x 1, VGA port x 1
I/O	
Front I/O Panel	RJ-45 GbE x 4 RS-232/422/485 COM Ports x 2 HDMI portx1 VGA port x 1 USB 3.2 Gen 1 x 2 Micro SIM slot x 1 Software programmable button x 1 Power LED x 1 HDD LED x 1 Status LED x 1 Bypass LED x 1 (Optional x 2)
Rear I/O Panel	DIN Rail/ Wallmount Lock
Top Panel	2-Pin Terminal Block +9~46VDC x 2
Environmental Parameters and Dimension	
Operating Temperature	-40°F ~ 167°F (-40°C ~ 75°C)
Storage Temperature	-40°F ~ 185°F (-40°C ~ 85°C)
Operating Humidity	10% ~ 80% relative humidity, non-condensing
Storage Humidity	10% ~ 80% @40°C; non-condensing
Vibration	0.5 g rms/ 5 ~ 500Hz / operation (2.5" SSD) 1.5 g rms/ 5 ~ 500Hz / non operation
Shock	10 G peak acceleration (11 m sec. duration), operation 20 G peak acceleration (11 m sec. duration), non operation

Specifications

System	
Form Factor	DIN Rail/ Desktop
Processor	Onboard Intel® Elkhart lake SoC
System Memory	204-pin DDR4 2133/2400MHz, SODIMM Up to 32GB with IBECC support
Chipset	—
Ethernet	Intel® i225 Gigabit Ethernet x 4
Bypass	1 pair , support up to 2 pairs (Optional)
BIOS	AMI SPI Flash BIOS
Serial ATA	SATA III port x 1 for 2.5"SSD support
CFast/mSATA	mSATA (Full size) socket colay SATAIII port x 1
Expansion Interface	Supports Mini-card slot x 1 with Micro SIM socket
USB	USB 3.2 Gen 1 x 2
Serial Port	Supports up to RS-232/422/485 COM Port x 2
Watchdog Timer	1~255 steps by software programmable
RTC	Internal RTC

Dimension

Unit: mm

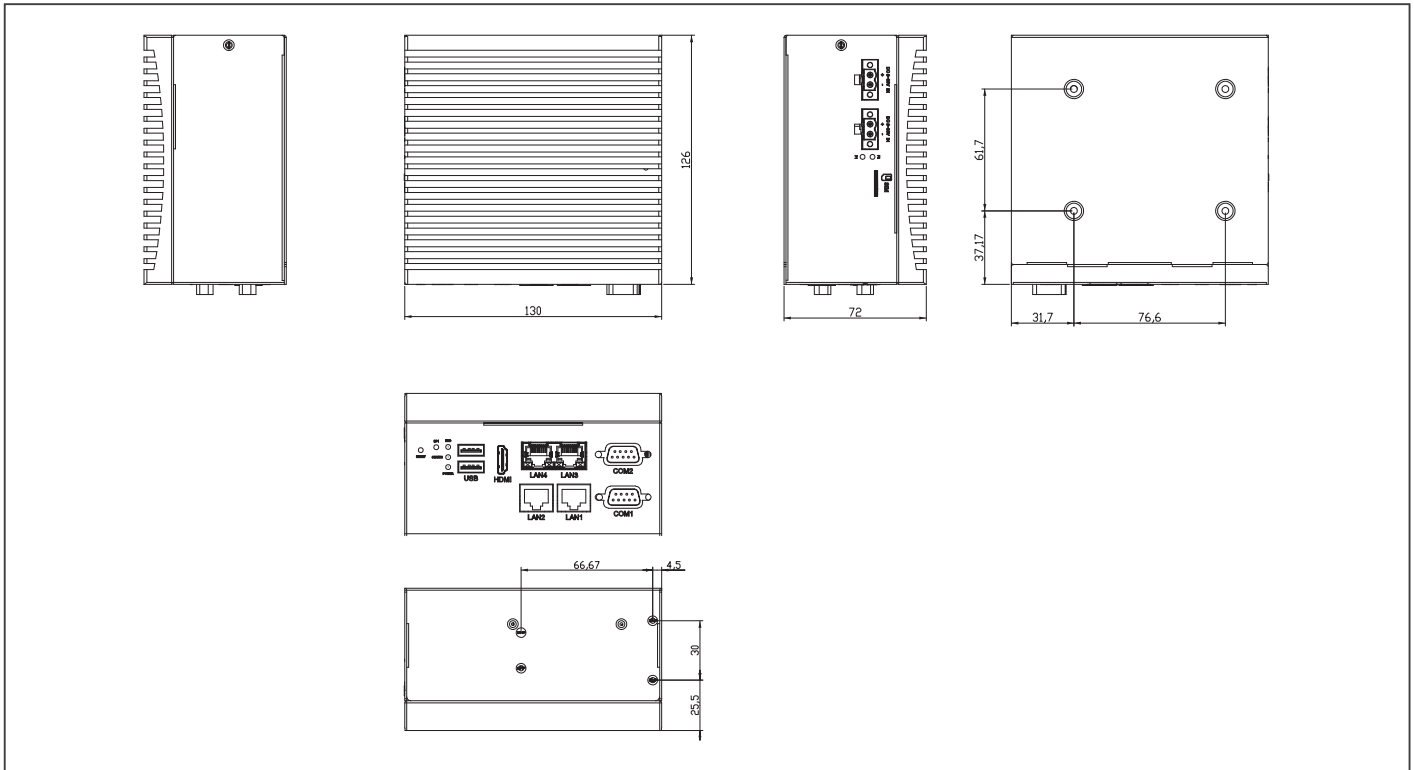

Ordering Information

Part Number	CPU	Memory	Bypass	Expansion Slot	Storage	LAN	USB	Console	System Fan	TPM	Display	Mounting	Power
ICS-6280	Onboard Intel® Elkhart lake SoC	204-pin DDR4 2133/2400MHz, SODIMM x 1 with IB ECC support	1 pair (optional 2 pairs)	mSATA (Full size) socket coloy SATAIII port x 1 Supports Mini-card slot x 1 with Micro SIM socket	mSATA (Full size) socket coloy SATAIII port x 1 2.5" SSD Bay x 1	4 x 1Gb RJ-45	USB3.0 Type A Port x 2	—	Fanless	Optional upon request	HDMI x 1 VGA x 1	DIN Rail	Redundant 9~48Vdc input

Packing List

- SATA Cable x 1
- SATA Power Cable x 1
- DIN Rail Kit x 1
- ICS-6280

Optional Accessories

- **9761627020**
Wallmount Kit (No Packing)
- **1255300407**
2 Pin Phoenix Contact 40W Power Adapter

04

► Industrial Servers



04

ZEUS-PURO PROJECT BASED

4U Rackmount Purley Platform Server System, Support Xeon® FPGA CPU

Front View



Rear View



Specifications

System	
Form Factor	4U Rackmount Server System
Processor	Intel® Xeon® Skylake-SP and Cascade Lake-SP Processors
System Memory	DDR4 2133/2400/2666 R-DIMM, Up to 512 GB
Chipset	Intel® C621
Ethernet	Intel® i211 Gigabit Ethernet x 2
Bypass	Depend on NIM module
BIOS	AMI BIOS
Serial ATA	SATA II port x 6
Storage	2.5" HDD x 6 or 3.5" HDD x 6, M.2 x 1
Expansion Interface	NIM slot x 4 (Project Base NIM Slot x 8) Option front PCIe [x16] slots x 2 Option rear side PCIe [x4] x 4 (or PCIe [x8] x 2) + PCIe [x8] x 2 (Or PCIe [x16] x 1) M.2 Slot x 1 Mini PCIe x 1
Watchdog Timer	1~255 steps by software programmable

Features

- 4U Rackmount Server System
- Dual Intel® Xeon® Processor Skylake-SP and Cascade Lake –SP processor
- Intel® Communications Chipset C621
- DDR4 2133/2400/2666 MHz DIMM (8 DIMM Per CPU) RDIMM x 16, Up to 512 GB
- IPMI Support
- Up to 32 Gigabit Ethernet Ports Via NIM (Project Base Up to 32 Gigabit Ethernet Ports Via NIM)
- 6 x 3.5" SATA HDD or 2.5" SATA HDD x 6, M.2 2260 Socket x 1
- Option Rear Side PCIe [x4] x 4 (or PCIe [x8] x 2) + PCIe [x8] x 2 (Or PCIe [x16] x 1)
- Option Front PCIe [x16] x 2
- Optional Parallel LCM with Keypad x 1
- RJ-45 Console x 1, USB 3.0 x 2, 1 GbE LAN x 2
- 800~1600W CRPS Redundant Power



RTC	Internal RTC
System Fan	5
Front I/O Panel	Power LED x 1, Status LED x 1, HDD Active LED x 1
Rear I/O Panel	AC Power Input x 1, Power Switch x 1, VGA port (Optional), Rear Expansion Slot (Option)
Color	Black
Power Supply	800 ~1600W Redundant PSU
Dimension	(480mm x 600mm x 176mm)
Power Consumption	TBD
MTBF (Hours)	TBD
Display	
Chipset	Intel® C621
Graphic Engine	From IPMI or Mini PCIe Option
Resolution	—
Connector	VGA Option
I/O	
Serial Port	RJ-45 Console x 1
K/B and Mouse	N/A
USB	USB 3.0 x 2
Environmental	
Operating Temperature	32°F ~ 104°F (0°C ~ 40°C)
Storage Temperature	-4°F ~ 140°F (-20°C ~ 60°C)
Operating Humidity	10% ~ 80% relative humidity, non-condensing
Storage Humidity	10% ~ 80% @40°C; non-condensing
Vibration	0.5 g rms/ 5 ~ 500Hz / operation (2.5" Hard Disk Drive) 1.5 g rms/ 5 ~ 500Hz / non operation
Shock	10 G peak acceleration (11 m sec. duration), operation 20 G peak acceleration (11 m sec. duration), non operation

Dimension

Unit: mm

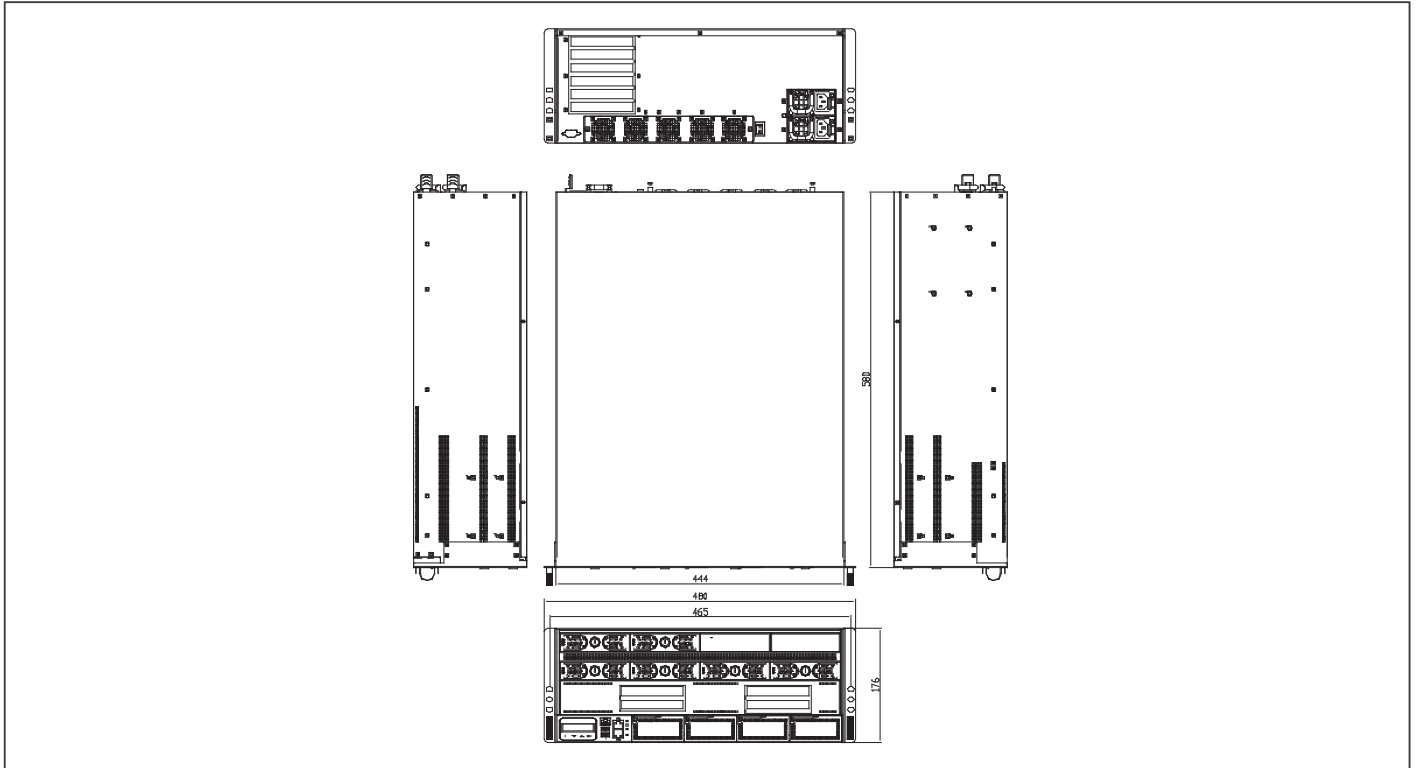

Ordering Information

- TBD

Packing List

- ZEUS-PURO

Optional Accessories

- TBD

ARES-WHIO PRELIMINARY

Intel® whitely Platform Server Board, Support Xeon® Single Ice Lake-SP CPU

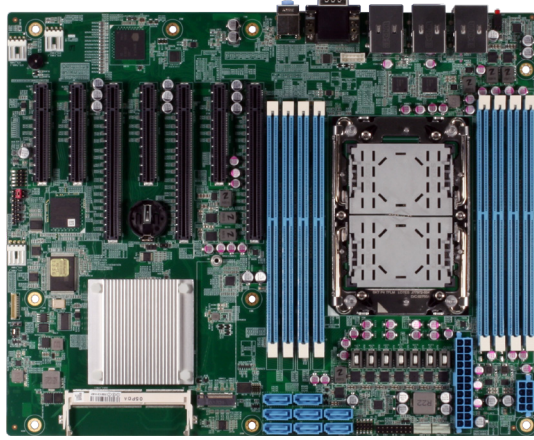

Features

- ATX Server Board
- Single Intel® Xeon® Processor Ice Lake-SP processor
- Intel® Communications Chipset C621A
- 8 x DDR4 2133/2400/2666 MHz DIMM Slot
- Intel Barlow Pass Optane DC Persistent Memory Up to 1TB
- 8 x SATA3 (6 Gbps) ports; RAID 0,1,5,10
- M.2 M-Key 2280 with PCIe x 4 Signal
- Dual LAN with Intel® i210 Gigabit Ethernet Controller
- External Dual USB 3.0 ports
- Audio In Out and VGA x 1
- IPMI Module support (Option)
- TPM D/I/O and Case open Support
- 6 USB 3.0 ports (6 rear); USB2.0 (2 rear to USB3.0, 2 by header to USB2.0) (BOM option)
- 1 x COM Port (1 x header)
- 3 x [PCI-E 3.0 x 16], 3 x [PCI-E 3.0 x 4]use [PCI x 8 Slot], 1 x [PCI-E-3.0 x 8]
- 5x 4-pin fan headers (up to 5 fans), 5 fans with tachometer status monitoring, Low noise fan speed control, Pulse Width Modulated (PWM) fan connectors, Status monitoring for on/off control, Status monitoring for speed control
- Monitoring for CPU and chassis environment, CPU thermal trip support, I2C temperature sensing logic, Thermal Monitor 2 (TM2) support, PECCI
- CPU / System Overheat LED, Suspend static indicator LED
- Operating Temperature Range 0°C ~ 50°C (32°F ~ 122°F)
- +12V, +3.3V, +5V, 1.05 (PCH), 1.2V (VDIMM), 3.3V standby, Chassis intrusion header, Monitors CPU voltages, VBAT

Specifications

System	
Form Factor	ATX Sever Board Whitely Platform
Processor	Single Intel® Xeon® ICE LAKE-SP Processors
System Memory	8 x DDR4 2133/2400/2666 R-DIMM Slot
Chipset	Intel®C621A
Ethernet	Intel® i210 Gigabit Ethernet x 2
COM	1 x Pin header
BIOS	AMI BIOS
Serial ATA	SATA II port x 8
Audio and VGA	1
Expansion Interface	3 x [PCI-E 3.0 x 16], 3 x [PCI-E 3.0 x 4]use [PCI x 8 Slot], 1 x [PCI-E-3.0 x 8]
Watchdog Timer	1~255 steps by software programming
RTC	Internal RTC
System Fan	5x 4-pin fan headers (up to 5 fans)
Front I/O Panel	USB 3.0 x 2 1 Gb RJ45 LAN x 2 AUDIO in and out x 1, VGA x 1
Rear I/O Panel	N/A
Color	N/A
Power Supply	
Dimension	305 × 244 mm
Power Consumption	TBD
MTBF (Hours)	TBD

Display	
Chipset	Intel C621A
Graphic Engine	TBD
Resolution	TBD
Connector	VGA
I/O	
Serial Port	COM x 1 Pin Header
K/B and Mouse	N/A
USB	USB 3.0 x 2
Environment	
Operating Temperature	0°C ~ 50°C (32°F ~ 122°F)
Storage Temperature	-4°F ~ 140°F (-20°C ~ 60°C)
Operating Humidity	10%~80% relative humidity, non-condensing
Storage Humidity	10%~80% @40°C; non-condensing
Vibration	0.5 g rms/ 5 ~ 500Hz / operation (2.5" Hard Disk Drive) 1.5 g rms/ 5 ~ 500Hz / non operation
Shock	10 G peak acceleration (11 m sec. duration), operation 20 G peak acceleration (11 m sec. duration), non operation

Dimension Unit: mm

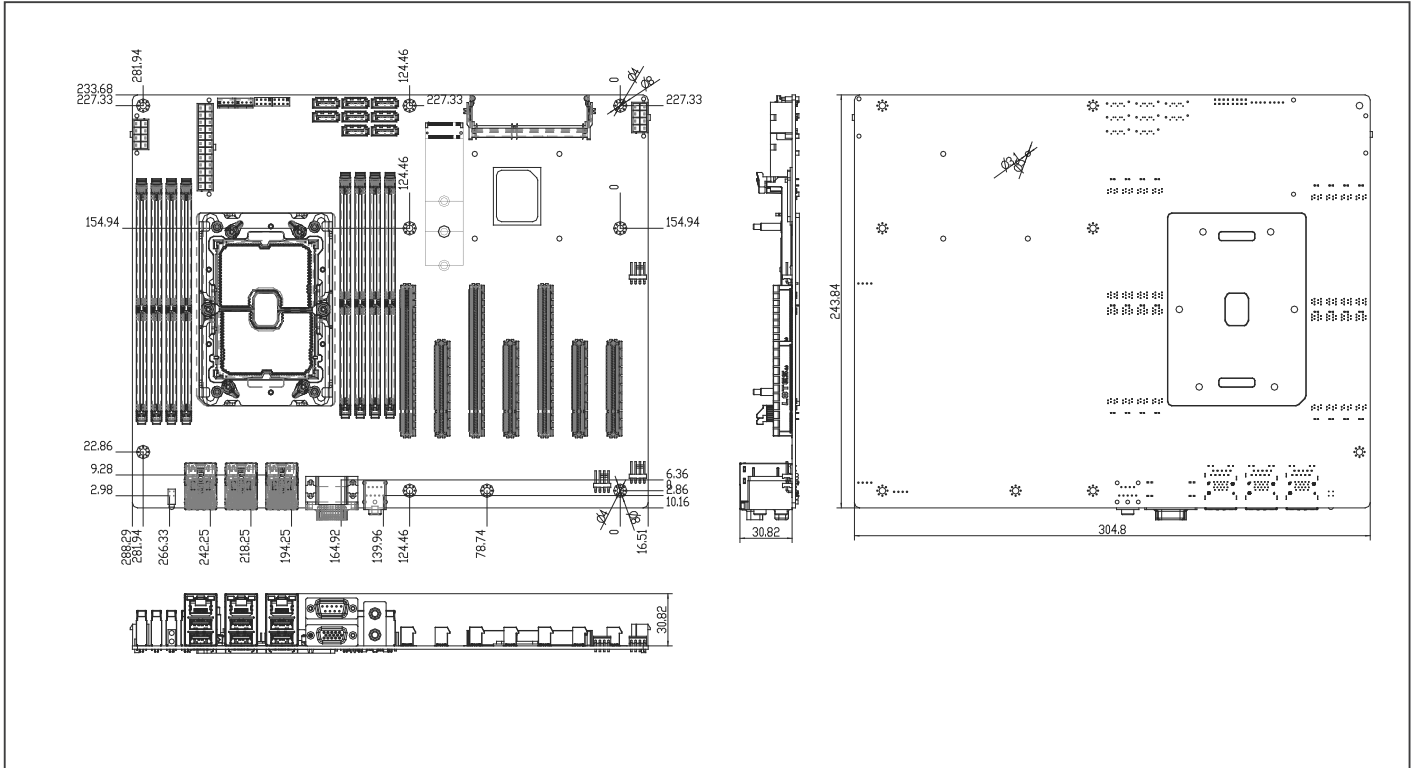

Ordering Information

- TBD

Packing List

- ARES-WHIO

Optional Accessories

- TBD

A series of horizontal dashed lines for writing.

▶ Memo

A series of horizontal dotted lines for writing.

Lined writing area consisting of 30 horizontal dashed lines for text entry.



2022

Focus • Agility • Competitiveness



AAEON Technology Inc.

5F, No. 135, Lane 235, Pao Chiao Rd., Hsin-Tien Dist, New Taipei City, 231, Taiwan, R.O.C.
Tel: +886-2-8919-1234 Fax: +886-2-8919-1056 E-mail: sales@aaeon.com.tw

LITERATURE ORDERING

Contact your local office for literature requests.

USA

California Office

324 W. Blueridge Ave, Orange, CA 92865
Toll Free: +1-877-TO-AAEON (1-877-862-2366)
TEL: +1-714-996-1800
FAX: +1-714-996-1811
E-mail: sales@aaeon.com
Tech Support: tech@aaeon.com

New Jersey Office

11 Crown Plaza, Hazlet, NJ 07730-2441
TEL: +1-732-203-9300
FAX: +1-732-203-9311
E-mail: sales@aaeon.com
Tech Support: tech@aaeon.com

EUR

Netherlands

AAEON EUROPE

Ekkersrijt 4090, 5692 DA Son, Science Park, Eindhoven
TEL: +31(0)499-745200
FAX: +31(0)499-462010
E-mail: sales@aaeon.eu

Germany

AAEON Technology GmbH

Monzastrasse 4e, 63225 Langen
TEL: +49(0)61033 74 79 00
FAX: +49(0)61033 74 79 49
E-mail: sales@aaeon.eu

France

AAEON France Office

Gare de Lyon, 37/39 Avenue Ledru-Rollin, CS 11237, 75012 Paris Cedex 12
TEL: +33 (0) 156 95 16 40
E-mail: sales@aaeon.eu

Italy

AAEON Italy Office

Viale Masini 12/14, 40126 Bologna
TEL: + 39 051 0923582
E-mail: sales@aaeon.eu

ASIA

China

AAEON Technology (Su Zhou) Inc.

Room 12, 2F, Building B, No.5 Xing Han Street, Suzhou Industrial Park, Jiang Su Province
TEL: +86-512-6762-5700
FAX: +86-512-6761-7337
E-mail: sales@aaeon.com.cn

Shanghai Branch Office

20F, Unit D, GEM Building, No.487 Tianlin Road, Xuhui District, Shanghai
TEL: +86-21-3367-5511
FAX: +86-21-3367-4238
E-mail: sales@aaeon.com.cn

Beijing Branch Office

Room 606-608 Block D, Jiahua Building, No.9, Shanghai 3rd Street, Haidian District, Beijing
TEL: +86-10-8278-0904
FAX: +86-10-8278-0214
E-mail: sales@aaeon.com.cn

Wuhan Branch Office

B1501, 111 Guanggu Time Square Guanshan st. Wuhan Hubei Province
TEL: +86-27-87606090
E-mail: sales@aaeon.com.cn

China

Chengdu Branch Office

Room 2204, 22F, Building6, No.666 JinCheng Avenue, GaoXin District, Chengdu City
TEL: +86-28-85120523
E-mail: sales@aaeon.com.cn

Guangzhou Branch Office

Room 1505.B2.No.122-124 kexue Road, High-Tech Development Zone, Guangzhou
TEL: +86-13534236621
E-mail: sales@aaeon.com.cn

Shenzhen Branch Office

Room 602,6th Floor,Building J, Zhongli Entrepreneurial Community, Liuxian 2 Road, Xinan Street, Baoan District, Shenzhen
TEL: +86-755-8304-7277
FAX: +86-755-8304-7272
E-mail: sales@aaeon.com.cn

Singapore

AAEON Technology Singapore PTE LTD.

57 Genting Lane, #07-00, Singapore 349564
TEL: +65-6749-8749
FAX: +65-6746-1595
E-mail: sales@aaeon.com.sg

