

RTC-900B

10.1" Rugged Tablet Computer with Intel® Atom™ E3800 Series Processor



Features

- Intel® Atom™ E3800 Series Processor
- DDR3L SDRAM 2GB
- 10.1" WXGA (1280 x 800) TFT LCD Display
- Projected Capacitive Multi-Touch Screen
- Li-Polymer High-Capacity Battery, 8 Hours Battery Life
- Rugged, Water and Dust Proof, IP65 Compliance
- Micro SD Card Slot, 5M Pixel Camera
- WLAN 802.11b/g/n, Bluetooth® 2.1 + EDR
- GPS Navigation, G-Sensor, Light Sensor
- Windows® Embedded 8 Standard (Default);
Windows® Embedded 8 Industry Pro (Optional)



Specifications

System	
Processor	Intel® Atom™ E3800 Series Processor 1.33 GHz
System Memory	DDR3L SDRAM, 2 GB (Up to 4GB)
LCD Display	10.1" WXGA (1280 x 800) 16:10 TFT LCD with Projected Capacitive Multi-Touch screen
Communication	WiFi 802.11 b/g/n, Bluetooth® 2.1+EDR (Bluetooth® Keyboard/Mouse support), 3G modem module (optional)
WiFi Frequency	2.4GHz ISM Bands 2.412-2.472 GHz, 2.484 GHz 5.15-5.25 GHz (FCC UNII-low band) for US/Canada, Japan and Europe 5.25-5.35 (FCC UNII-middle band) for US/Canada and Europe 5.47-5.725 GHz for Europe 5.725-5.825 GHz (FCC UNII-high band) for US/Canada BT: 2402MHz~2483MHz
WiFi Output Power	0.14W
I/O Port	DC-in Jack x 1, Mini USB Port x 1, Mini HDMI x1, Micro SD Card Slot x 1, 3.5 mm stereo headphone jack x 1, Built-in Speaker & Microphone, SIM Card Slot x 1
Storage	60GB/ 120GB mSATA MLC
Navigation	GPS, AGPS
Camera	Front camera: 2Mega, Real camera: 5Mega
Other	Built-in Light Sensor, Built-in G-Sensor
OS	Windows® Embedded 8 Standard (Default) Windows® Embedded 8 Industry Pro (Optional)
MTBF (Hours)	—
Mechanical	
Color	Black
Dimension	10.65" x 7.42" x 0.96" (270.4mm x 188.4mm x 24.29 mm)
Gross Weight	2.4 lb (1.1 Kg)
Environmental	
Operating Temperature	-4°F ~ 131°F (-20°C ~ 55°C)
Storage Temperature	-67°F ~ 131°F (-55°C ~ 55°C)
Water & Dust Proof	IP65 compliance
Vibration	Meets MIL-STD 810G-514.6, Procedure I Cat. 24, Fig. 514.6E-1 & 514.6E-2 (Unit is non-operating), ASTM 4169-99 Truck Assurance Level II, Schedule E (Unit is operating)
Drop	26 drops of 48 inches height to 2 inches plywood over concrete with unit off, MIL-STD 810G-516.6, Procedure IV
ESD	Air +/- 8KV, Contact +/- 4KV
EMC/ Safety	CE / FCC Class B / UL

RTC-900B

Dimension

Unit: mm

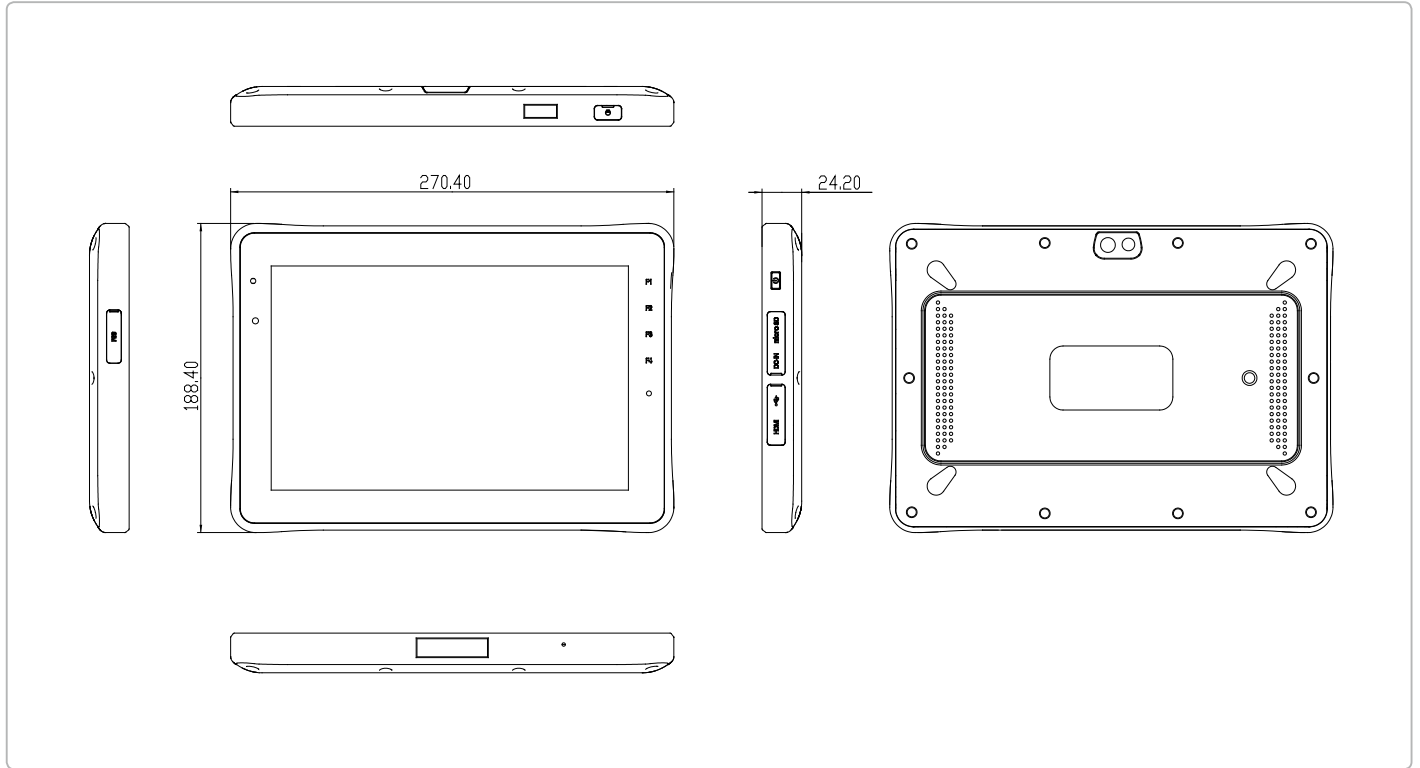

Packing List

- 1757302404
(TF)Power Adapter, 100~240V, 12V/2A, LTE, LTE24E-S2-2C6-English
- Product CD
- RTC-900B

Ordering Information

- TBD

Optional Accessories

- AP-OT9789666663
Car Mount for RTC-700T & RTC-700R & RTC-900R
- AP-PS1757402101
Car Adaptor, Car Adaptor, DC/DC, 12 ~ 24V/12V, 2.7A/1.8A, 21.6W, BLACK, A0EM, C11A-1215CD0-C2