

UP Squared Pro TWL PRELIMINARY

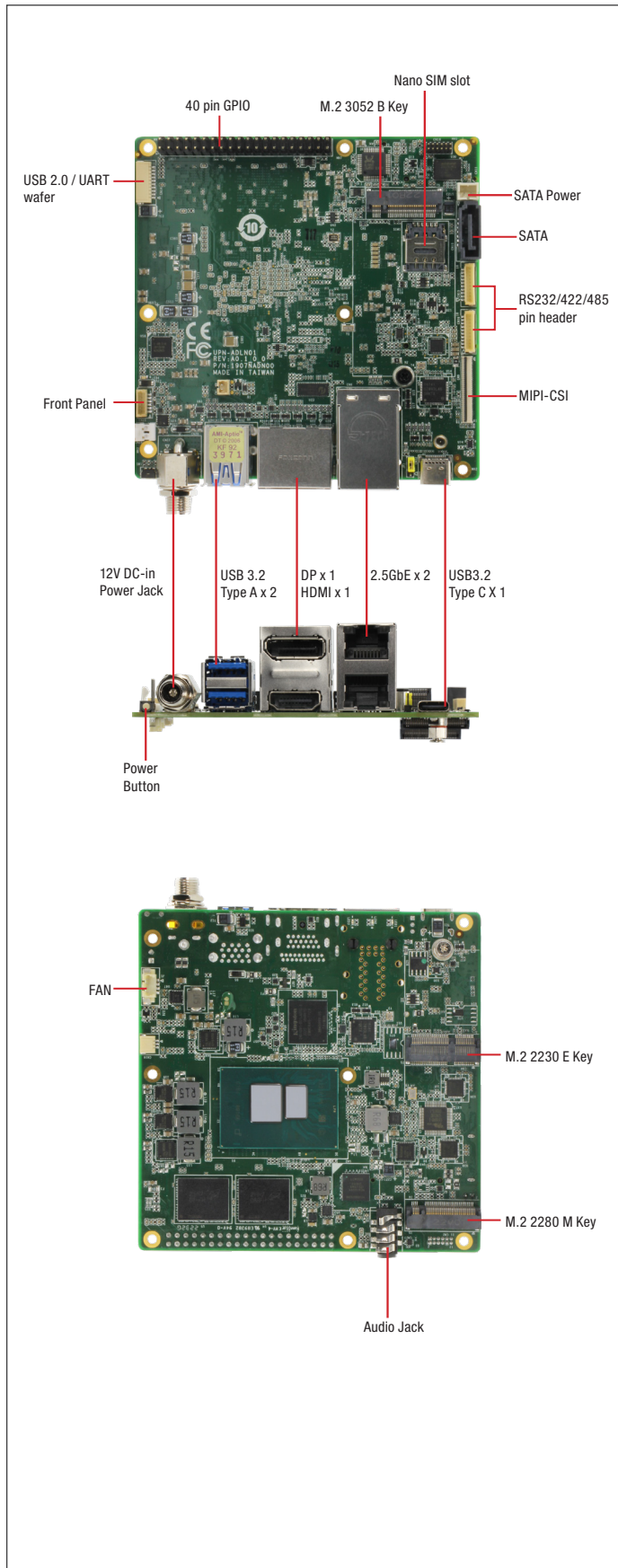

UP Squared Pro 7000 Developer Board with Intel Atom® x7000E/x7000RE Series, Intel® Processor N-series, and Intel® Core™ i3-N305 Processor



Features

- Intel Atom® x7000E/x7000RE Series, Intel® Processor N-series, and Intel® Core™ i3-N305 Processor
- Onboard LPDDR5 Memory up to 16GB
- Onboard eMMC Storage up to 64GB
- 2.5GbE x 2 (Intel® I226-IT)
- USB 3.2 x 3 (Type A x 2, Type C x 1)
- 40 Pin GPIO x 1
- DP 1.2 x 1/DP 1.4a x 1/HDMI 2.0b x 1
- RS232/422/485 Wafer x 2
- M.2 2230 E-Key/M.2 2280 M-Key/M.2 3052 B-Key x 1
- SATA 6Gb/s x 1
- TPM 2.0
- 12V DC-in, 6A



Specifications

System	
Processor	Intel® Core3 N355 Intel® Processor N250 Intel® Processor N150
Graphics	Intel®Graphics up to 32EU w/ INT8 extension
Memory	Up to 16GB onboard LPDDR5
Storage	Up to 64GB onboard eMMC
I/O	HDMI 2.0b x 1 DP 1.2 x 1 DP 1.4a via USB Type C Audio Jack x 1 (Mic-in+Line-out) RS-232/422/485 via 10 Pin header x 2
Camera	MIPI-CSI via 61-Pin FPC Connector x 1
USB	USB 2.0 x 2 (via 10 Pin Header x 1) USB 3.2 Gen 2 (Type-A) x 2 USB 3.2 Gen 2 (Type-C) x 1
Expansion	40 Pin GPIO x 1 M.2 2230 E-Key x 1 (CNVI, PCIe Gen 3 [x1], USB 2.0) M.2 2280 M-Key x 1 (PCIe Gen 3 [x2]) M.2 3052 B-Key x 1 (USB 3.2 Gen 2 only) with Nano SIM slot (USB 3.0) SATA 6Gb/s x 1
Display Interface	HDMI 2.0b x 1 DP 1.2 x 1 DP 1.4a via USB Type C
Ethernet	2.5GbE x 2 (Intel® I226-IT)
Security	Onboard TPM 2.0
RTC	Yes
OS Support	Windows 11 LTSC, Windows 10 LTSC Ubuntu 22.04 LTS/Kernel 6.6+, Ubuntu 24.04 LTS/Kernel 6.8+ Yocto 5+
Power Requirement	
Power	12V DC-in
Power Supply Type	AT/ATX (ATX as default)
Power Consumption (Typical)	TBD
Mechanical	
Dimension	4" x 4" (101.6mm x 101.6mm)
Net Weight	0.44 lbs (0.20kg)
Gross Weight	0.77 lbs (0.35kg)
Environment	
Operating Temperature	WITAS1 -4°F ~ 158°F (-20°C ~ 70°C)
Operation Humidity	0% ~ 90% relative humidity, non-condensing
MTBF	TBD
Certification	CE/FCC Class A, RoHS Compliant, REACH

Packing List

- UP Squared Pro TWL with heatsink



Block Diagram

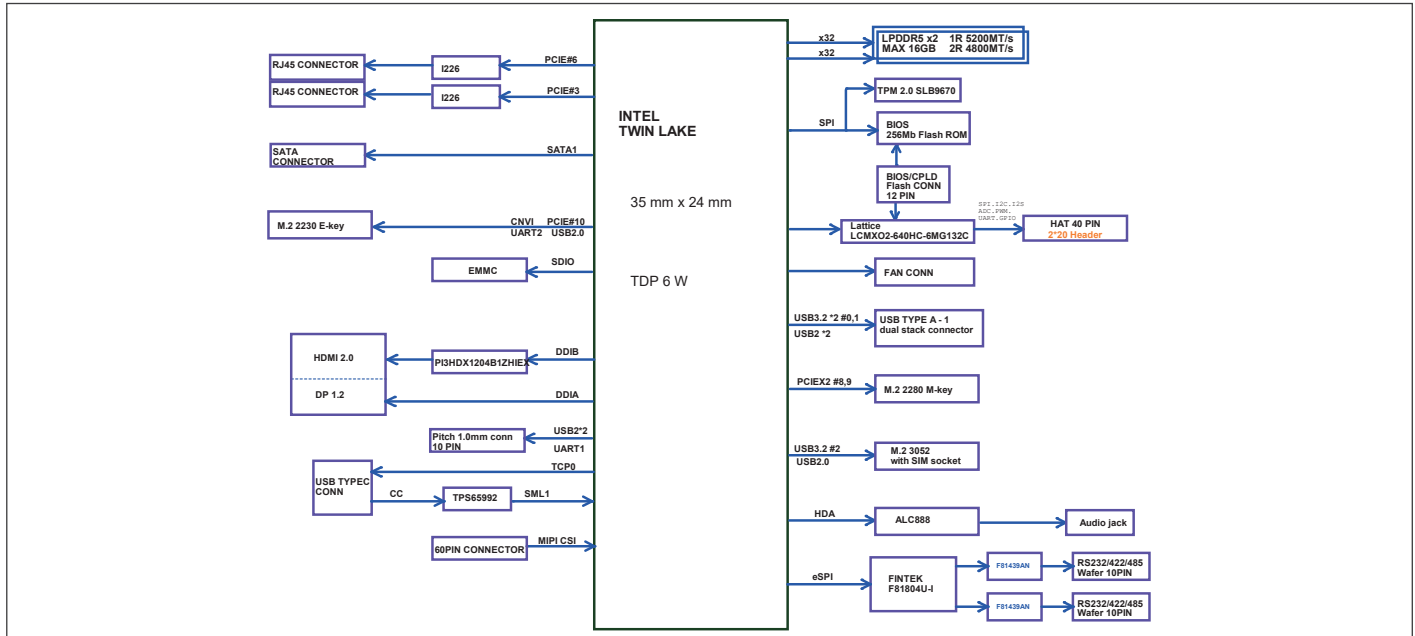

Dimension

Unit: mm

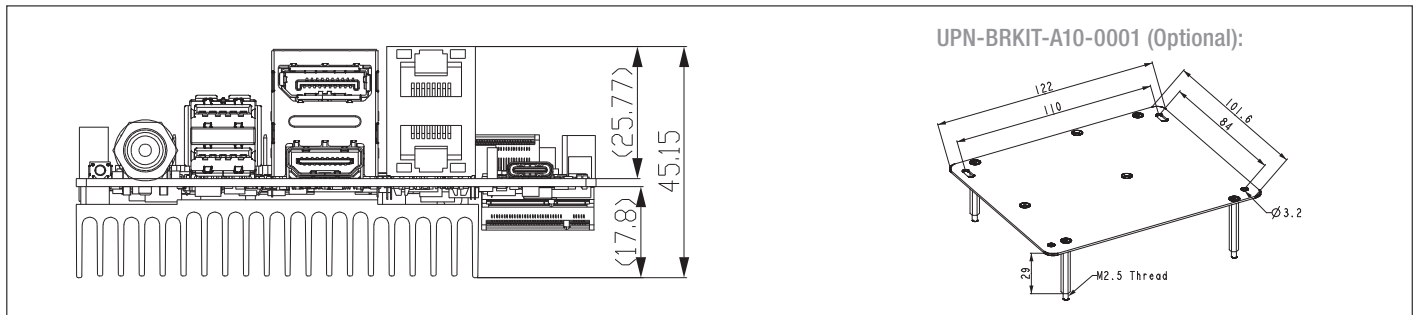

Ordering Information

Part number	CPU	Memory	Storage	Operating Temp
UPN-TWLN150-A10-0864	Intel® Processor N150	8GB	64GB	-20°C ~ 70°C
UPN-TWLN250-A10-0864	Intel® Processor N250	8GB	64GB	-20°C ~ 70°C
UPN-TWLI3-A10-0864	Intel® Corei3 N355	8GB	64GB	-20°C ~ 70°C

Optional Accessories

Part Number	Description
1255X00032	(TF)AC/DC Adapter.Input AC:100~240V.Output DC:12V.MAX 72W.6.0A.180D.W/ LOCK.EDAC. EA10681U(120)
170X000799	(TF)Power Cord. 3P. 125V. 10A. 180D. USA. 1. 8M. I-SHENG. SP305B/IS-14N SVT 18/3 60C CT-12 Black
170X000800	(TF)Power Cord. 3P. 250V. 10A. VDE. 1. 8M. I-SHENG. SP23/IS-14N H05VV-F 3G 0. 75 CT-12 Black
170X000815	(TF)Power Cord. 3P. 250V. 10A. 180D. CHINA. 1. 8M. I-SHENG. SP506A/IS-14N RVV 300/500V 3X0. 75 CT-12 Black
170X000806	(TF)Power Cord. 3P. 125V. 7A. 1. 8M. I-SHENG. U4NCB3T6B1218002. SP305B/IS-14N VCTF. Black. BSMI
170X000806	(TF)Power Cord.3P.125V/7A.PSE Certificate.1.8M.I-SHENG.U4NCB3P6C1218002.SP305B/IS-14N VCTF 0.75/3 Black 1.8M
170X000810	(TF)Power Cord.3P.250V.16A.Korea.1.8M.I-SHENG.SP23/IS-14N H05VV-F 3G 0.75 CT-12 Black
170X000805	(TF)Power Cord.3P.250V.10A.SWISS.1.8M.I-SHENG.SP-027C/IS-14N H05VV-F 3G 0.75mm CT-12 Black
1709070500	SATA cable
1702150155	SATA power cable (15cm)
1702150306	SATA power cable (30cm)
1701100180	COM Cable
UPCR-CAMB-A10-0001	MIPI-CSI Camera RVP Converter Kit for UP Squared Pro 7000/UP Squared i12/UP Xtreme i12
UPCR-HDMI-A10-0001	HDMI IN carrier board for for UP Squared Pro 7000/UP Squared i12/UP Xtreme i12
UPCR-CAN1-A10-0001	UP CAN Bus Carrier Board with USB/UART interface for UP product line
UPN-BRKIT-A10-0001	Bracket KIT of board fixture for all UP series