

EMB-Q77B

Mini-ITX Embedded Motherboard with Intel® 3rd/2nd Generation Core™ i7/i5/i3 Processor, USB 3.0 x 4 and SATA3 x 2

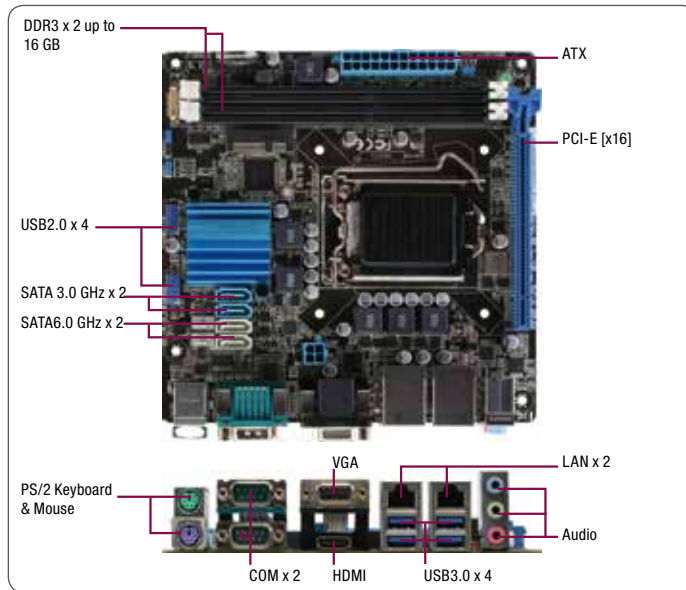

Features

- Intel® 3rd/2nd Generation Core™ i7/i5/i3/Processors
- DDR3 1600/1333 MHz DIMM x 2, Up to 16 GB
- Dual Independent Display: VGA, HDMI
- Dual Intel® Gigabit Ethernet
- Onboard TPM Infineon SLB9635 TT 1.2
- PCI-E [x16] x 1, Half-size Mini-Card x 1 for mSATA (Optional)
- Support USB3.0 and SATA 6.0 Gb/sec



Specifications

System	
Form Factor	Mini-ITX
Processor	LGA1155 socket for Intel® 3rd/2nd Generation Core™ i7/ i5/ i3/ Pentium® / Celeron® Processors (Supports Intel® CPU up to 95W)
Memory	DDR3 1600/1333/1066 MHz DIMM x 2, up to 16 GB, Non-ECC, Un-buffered Memory
Chipset	Intel® Q77
I/O Chipset	NCT 6779D
Ethernet	Intel® 82579LM (Support Intel® I AMT 8.X)/ Intel® 82583V, Gigabit Ethernet x 2
Audio	Realtek® ALC887
BIOS	64 M bit Flash ROM x 2, AMI BIOS
Wake On LAN/PXE	Yes (WOL / PXE)
Watchdog Timer	1~255 steps programmable
TPM	Infineon SLB9635 TT 1.2
H/W Monitor	Temperature Monitor on CPU/Chassis, Voltage Monitor on Vcore/5V/3.3V/12V, Fan Monitor on CPU/Chassis
Expansion Slots	PCI-E 3.0/2.0[x16] x 1, Mini-Card (Optional mSATA) x 1 (Half-size)
Battery	Lithium battery
Power Requirement	ATX
Power Consumption	—
Board Size	6.7" x 6.7" (170mm x 170mm)
Gross Weight	1.1 lb (0.5 kg)
Operating Temperature	32~140°F (0~60°C)
Operating Humidity	0%~90%RH, non-condensing
Smart Fan Control	CPU Fan / Chassis Fan
Power State	S3, S4, S5
Power Requirement	24-pin ATX connector x 1 4-pin ATX 12V Power connector x 1
Power Compliance	Compliant with EuP / ErP
Certificate	CE & FCC
MTBF(Hours)	100,000
Display	
Graphics Engine	Intel® HD Graphics
VGA	VGA x 1, Up to 1920 x 1200 @60 Hz
DVI	—
HDMI	HDMI x 1, Up to 1920 x 1200 @60 Hz
LVDS	—
eDP	—
DP	—
Backlight Control	—

I/O	
Storage	SATA 6.0 Gb/s x 2 (gray), SATA 3.0 Gb/s x 2 (blue), support RAID 0/1/10/5
USB	USB 3.0 x 4 (on rear panel) USB 2.0 x 4 (on mid-board, p=2.54mm)
Audio I/O	Line-in, Mic-in, Line-out
LAN I/O	RJ-45 x 2
Serial Port	RS-232/422/485 x 1 supports 5V/12V/RI option (COM1, D-Sub 9) RS-232 x 1 (COM2, D-Sub 9)
Parallel Port	—
PS/2 Port	keyboard / Mouse with PS/2 connector
DIO	—
FAN	CPU Fan connector x 1 (4-pin) Chassis Fan connector x 1 (4-pin)

Packing List

- SATA Cable
- I/O Shield
- Product CD
- EMB-Q77B

EMB-Q77B

Block Diagram

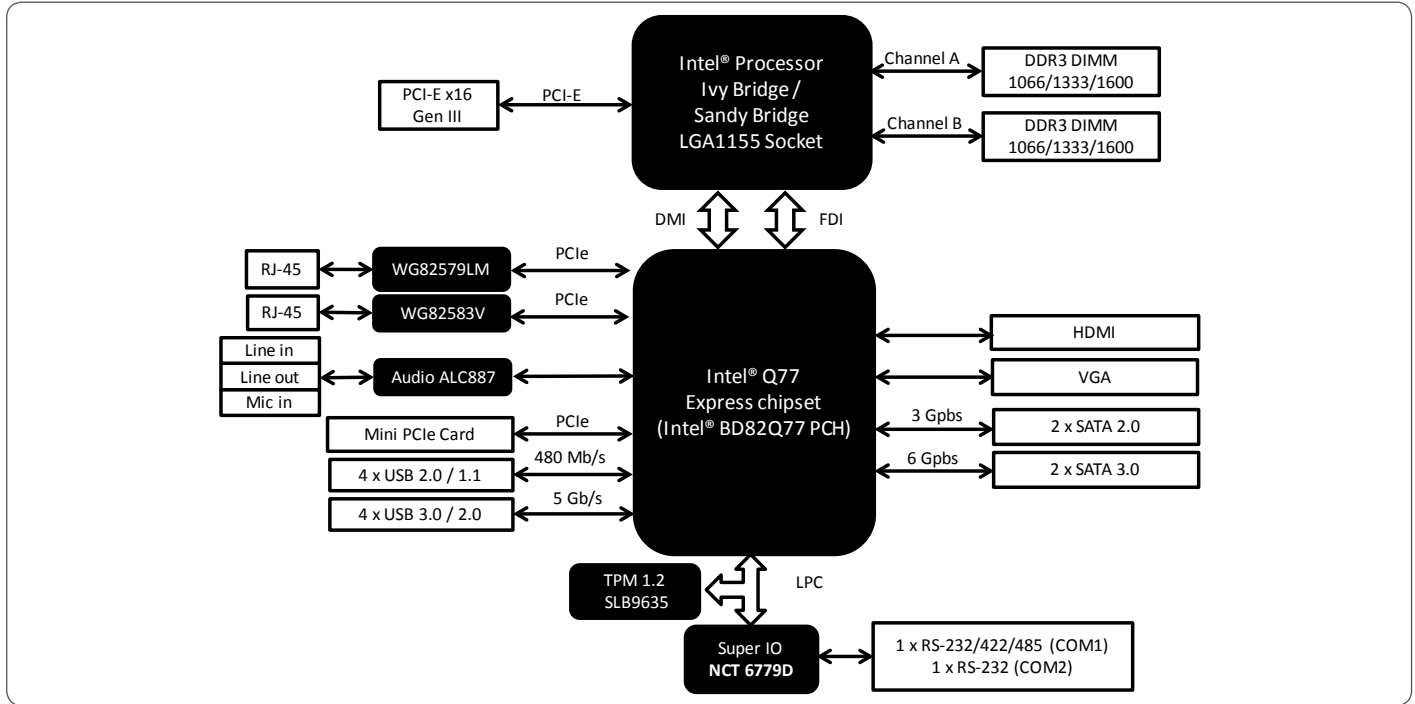

Dimension

Unit: mm

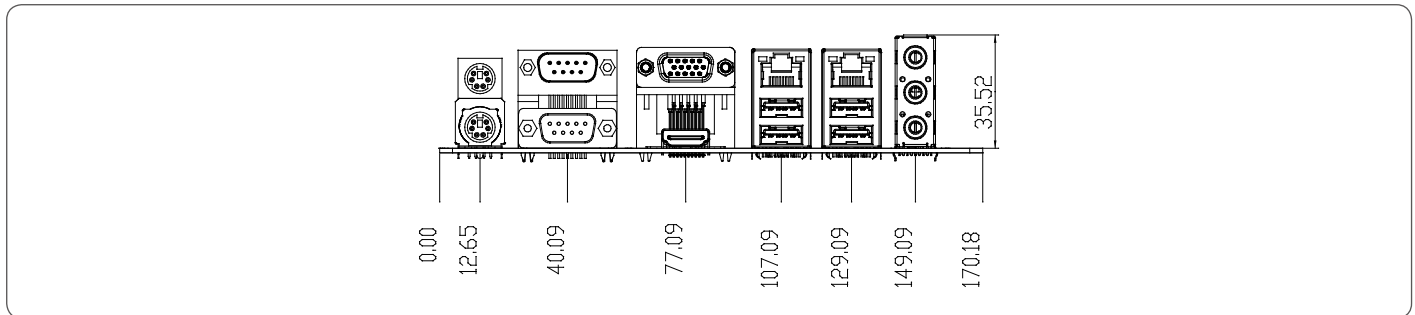

Order Information

Part Number	CPU	RAM	Fan/Fanless	Display	Storage	LVDS	LAN	USB	RS-232	RS-232/422/485	Expansion Slot	Power	TPM	Temp.
EMB-Q77B-A10-MS	Socket	DIMM	FAN	HDMI/VGA	SATA3 x 2 SATA2 x 2 mSATA x 1	—	GbE x 2	USB 3.0 x 4, USB 2.0 x 4	1	1	PCI-E(x16) x 1, Half-size Mini-Card (Optional mSATA) x 1	ATX	Onboard	0~60°C

Optional Accessories

- **1759200172**
CPU Cooler (2-Ball, Screw with Retention Plate)
- **175921156B**
CPU Cooler (2-Ball, Push-pin Type)
- **1709100330**
USB 2.0 cable (9P, 330MM, p=2.54mm, w/bracket)
- **1701100206**
COM Cable (200MM, p=2.00mm)
- **1700060192**
PS/2 Cable (6P, 190mm, P=2.0mm)
- **170910020K**
USB 2.0 cable (9P, 200MM, p=2.54mm, w/o bracket)