

**EMB-Q77A**

**Industrial Motherboard**

## **Copyright Notice**

This document is copyrighted, 2013. All rights are reserved. The original manufacturer reserves the right to make improvements to the products described in this manual at any time without notice.

No part of this manual may be reproduced, copied, translated, or transmitted in any form or by any means without the prior written permission of the original manufacturer. Information provided in this manual is intended to be accurate and reliable. However, the original manufacturer assumes no responsibility for its use, or for any infringements upon the rights of third parties that may result from its use. The material in this document is for product information only and is subject to change without notice. While reasonable efforts have been made in the preparation of this document to assure its accuracy, the original manufacturer assumes no liabilities resulting from errors or omissions in this document, or from the use of the information contained herein.

The original manufacturer reserves the right to make changes in the product design without notice to its users.

## **Acknowledgments**

All other products' name or trademarks are properties of their respective owners.

- AMI is a trademark of American Megatrends Inc.
- Intel®, Core™ are trademarks of Intel® Corporation.
- Microsoft Windows® is a registered trademark of Microsoft Corp.
- IBM, PC/AT, PS/2, and VGA are trademarks of International Business Machines Corporation.

The original manufacturer reserves the right to make changes in the product design without notice to its users.

All other product names or trademarks are properties of their respective owners.

## Contents

|                  |   |      |
|------------------|---|------|
| <b>Chapter 1</b> | <b>Product overview</b>                               |      |
| 1.1              | Package contents.....                                 | 1-1  |
| 1.2              | Features .....  | 1-1  |
| 1.3              | Specifications.....                                   | 1-2  |
| <b>Chapter 2</b> | <b>Motherboard information</b>                        |      |
| 2.1              | Before you proceed .....                              | 2-1  |
| 2.2              | Motherboard layout.....                               | 2-2  |
| 2.3              | Screw size.....                                       | 2-4  |
|                  | 2.3.1 Component side.....                             | 2-4  |
|                  | 2.3.2 Solder side .....                               | 2-5  |
| 2.4              | Central Processing Unit (CPU) .....                   | 2-6  |
|                  | 2.4.1 Installing the CPU .....                        | 2-7  |
|                  | 2.4.2 CPU heatsink and fan assembly installation..... | 2-9  |
| 2.5              | System memory .....                                   | 2-11 |
|                  | 2.5.1 Installing a DIMM .....                         | 2-12 |
| 2.6              | Jumpers .....   | 2-13 |
| 2.7              | Onboard LEDs .....                                    | 2-15 |
| 2.9              | Connectors .....                                      | 2-16 |
|                  | 2.9.1 Rear panel connectors.....                      | 2-16 |
|                  | 2.9.2 Internal connectors .....                       | 2-19 |
| <b>Chapter 3</b> | <b>BIOS setup</b>                                     |      |
| 3.1              | BIOS setup program .....                              | 3-1  |
|                  | 3.1.1 BIOS menu screen.....                           | 3-2  |
|                  | 3.1.2 Menu bar .....                                  | 3-2  |
| 3.2              | Main menu .....                                       | 3-3  |
|                  | 3.2.1 System Language [English] .....                 | 3-3  |
|                  | 3.2.2 System Date [Day MM/DD/YYYY] .....              | 3-3  |
|                  | 3.2.3 System Time [HH:MM:SS] .....                    | 3-3  |
|                  | 3.2.4 Security .....                                  | 3-3  |

|                     |   |             |
|---------------------|---|-------------|
| <b>3.3</b>          | <b>Advanced menu .....</b>                            | <b>3-4</b>  |
| 3.3.1               | Trusted Computing.....                                | 3-4         |
| 3.3.2               | CPU Configuration .....                               | 3-5         |
| 3.3.3               | SATA Configuration .....                              | 3-6         |
| 3.3.4               | System Agent Configuration .....                      | 3-7         |
| 3.3.5               | Intel TXT(LT) Configuration .....                     | 3-8         |
| 3.3.6               | AMT Configuration .....                               | 3-8         |
| 3.3.7               | USB Configuration .....                               | 3-9         |
| 3.3.8               | Onboard Devices Configuration.....                    | 3-10        |
| 3.3.9               | APM .....   | 3-12        |
| 3.3.10              | Network Stack.....                                    | 3-13        |
| <b>3.4</b>          | <b>Monitor menu .....</b>                             | <b>3-14</b> |
| 3.4.1               | CPU Temperature / MB Temperature [xxx°C/xxx°F].....   | 3-14        |
| 3.4.2               | CPU / Chassis Fan Speed .....                         | 3-14        |
| 3.4.3               | CPU Q-Fan Control [Enabled] .....                     | 3-15        |
| 3.4.4               | CPU Voltage, 3.3V Voltage, 5V Voltage, 12V Voltage .. | 3-17        |
| <b>3.5</b>          | <b>Boot menu .....</b>                                | <b>3-18</b> |
| 3.5.1               | Fast Boot [Enabled] .....                             | 3-18        |
| 3.5.2               | Bootup NumLock State [On] .....                       | 3-19        |
| 3.5.3               | Wait for 'F1' If Error [Disabled].....                | 3-19        |
| 3.5.4               | Option ROM Messages [Force BIOS].....                 | 3-19        |
| 3.5.5               | INT19 Trap Response [Postponed].....                  | 3-19        |
| 3.5.6               | CSM (Compatibility Support Module).....               | 3-20        |
| 3.5.7               | Secure Boot .....                                     | 3-20        |
| 3.5.8               | Boot Option Priorities.....                           | 3-22        |
| 3.5.9               | Boot Override.....                                    | 3-22        |
| <b>3.6</b>          | <b>Tools menu .....</b>                               | <b>3-23</b> |
| 3.6.1               | EZ Flash 2 Utility.....                               | 3-23        |
| 3.6.2               | DRAM SPD Information .....                            | 3-23        |
| <b>3.7</b>          | <b>Exit menu.....</b>                                 | <b>3-24</b> |
| <br><b>Appendix</b> |   |             |
|                     | <b>Notices.....</b>                                   | <b>A-1</b>  |

# Chapter 1

## Product overview

### 1.1 Package contents

Check your industrial motherboard package for the following items.

- 1 x Industrial Motherboard
- 1 x SATA Cable
- 1 x I/O Shield
- 1 x Support CD



---

If any of the above items is damaged or missing, contact your distributor or sales representative immediately.

---

### 1.2 Features

- Intel® Socket 1155 for 3<sup>rd</sup>/2<sup>nd</sup> Generation Core™ i7/Core™ i5 / Core™ i3 / Pentium® / Celeron® Processors up to 95W
- Two 240-pin Dual Channel DDR3 1600/1333/1066MHz DIMMs up to 16GB
- SATA 6.0 Gb/s x 2, SATA 3.0 Gb/s x 2 (supports RAID 0/1/5/10), USB3.0 x 4, USB2.0 x 8, COM x 2
- PCI-Express[x16] x 1, Mini Card (USB+PCIe) Half size x 1
- EuP/ErP Compliance

## 1.3 Specifications

| SYSTEM                |   |
|-----------------------|---|
| Form factor           | Mini-ITX  |
| CPU                   | LGA1155 socket for Intel® 3 <sup>rd</sup> /2 <sup>nd</sup> Generation Core™ i7 / Core™ i5 / Core™ i3 / Pentium® / Celeron® processors<br>Supports Intel® 22/32nm CPU up to 95W<br>Supports Intel® Turbo Boost Technology 2.0*<br>*Intel® Turbo Boost Technology 2.0 support depends on the CPU types. |
| Memory                | 2 x DIMM (8GB per DIMM), max. 16GB, unbuffered, non-ECC<br>DDR3 1600 / 1333 / 1066 MHz<br>Dual-channel memory architecture  |
| Chipset               | Intel® Q77 Express Chipset  |
| I/O Chipset           | NCT6779D  |
| Ethernet              | 1 x Intel® 82579LM Gigabit LAN (Supports Intel® AMT 8.X)<br>1 x Intel® 82583V   |
| BIOS                  | 128Mbit Flash AMI BIOS ROM  |
| Wake on LAN           | Yes (WOL/PXE)   |
| Watchdog Timer        | 1~255 steps by software program   |
| TPM                   | Infineon SLB9635 TT 1.2   |
| H/W Status Monitor    | Monitors CPU/Chassis temperature<br>Monitors Vcore/5V/3.3V/12V voltages<br>Monitors CPU/Chassis fan speed   |
| Smart Fan Control     | CPU Fan/Chassis Fan   |
| Power State           | S3, S4, S5  |
| Expansion slot        | 1 x PCI Express 3.0/2.0 x16 slot<br>1 x Mini Card (USB+PCIe) Half size  |
| Battery               | Lithium battery   |
| Power requirement     | 1 x 24-pin ATX connector<br>1 x 4-pin ATX 12V power connector   |
| Board size            | 6.7 in. x 6.7 in. (17.0 cm x 17.0 cm)   |
| Gross weight          | 0.94 lb (0.426 Kg)  |
| Operating temperature | 32°F~140°F (0°C~60°C)   |
| Storage temperature   | -40°F~185°F (-40°C~85°C)  |
| Operating humidity    | 0%~90% relative humidity, non-condensing  |
| Power compliance      | Compliant with Eup/ErP  |
| Certificate           | CE/FCC  |

(continued on the next page)

| <b>DISPLAY</b>          |   |
|-------------------------|---|
| <b>Chipset</b>          | Intel® Graphics Media Accelerator   |
| <b>Resolution</b>       | Up to 1920x1200@60Hz for DVI-D<br>Up to 1920x1200@60Hz for DVI-I  |
| <b>Output interface</b> | 1 x DVI-D<br>1 x DVI-I  |
| <b>I/O</b>              |   |
| <b>Storage</b>          | 2 x SATA 6.0Gb/s ports<br>2 x SATA 3.0Gb/s ports<br>RAID 0 / 1 / 5 / 10   |
| <b>Serial port</b>      | 1 x RS-232/422/485 supports 5V/12V/RI option (COM1, box header)<br>1 x RS-232 (COM2, box header)                              |
| <b>USB</b>              | 4 x USB3.0 (2 ports at mid-board, 2 ports at rear panel)<br>8 x USB2.0 (2 ports at mid-board, 6 ports at rear panel)          |
| <b>Fan</b>              | 1 x CPU Fan connector (4-pin)<br>1 x Chassis Fan connector (4-pin)  |
| <b>RTC</b>              | Internal RTC  |
| <b>Keyboard/Mouse</b>   | 1 x PS/2 Keyboard / mouse port on rear I/O  |
| <b>Audio</b>            | Realtek ALC887, Mic-in/Line-in/ Line-out<br>1 x Internal speaker connector<br>1 x Front panel audio connector (supports AAFP) |
| <b>Ethernet</b>         | 2 x RJ-45 ports on rear I/O   |
| <b>Display</b>          | 1 x DV-D port on rear I/O<br>1 x DVI-I port on rear I/O   |
| <b>Others</b>           | 1 x Front panel connector (Pin header)<br>1 x Chassis intrusion   |





# Chapter 2

## Motherboard information

### 2.1 Before you proceed

Take note of the following precautions before you install motherboard components or change any motherboard settings.



---

**CAUTION!**

- Unplug the power cord from the wall socket before touching any component.
  - Before handling components, use a grounded wrist strap or touch a safely grounded object or a metal object, such as the power supply case, to avoid damaging them due to static electricity.
  - Hold components by the edges to avoid touching the ICs on them.
  - Whenever you uninstall any component, place it on a grounded antistatic pad or in the bag that came with the component.
  - Before you install or remove any component, ensure that the ATX power supply is switched off or the power cord is detached from the power supply. Failure to do so may cause severe damage to the motherboard, peripherals, or components.
-

# 2.2 Motherboard layout



**NOTE:** Place four screws into the holes indicated by circles to secure the motherboard to the chassis.



**CAUTION!** Do not overtighten the screws! Doing so can damage the motherboard.

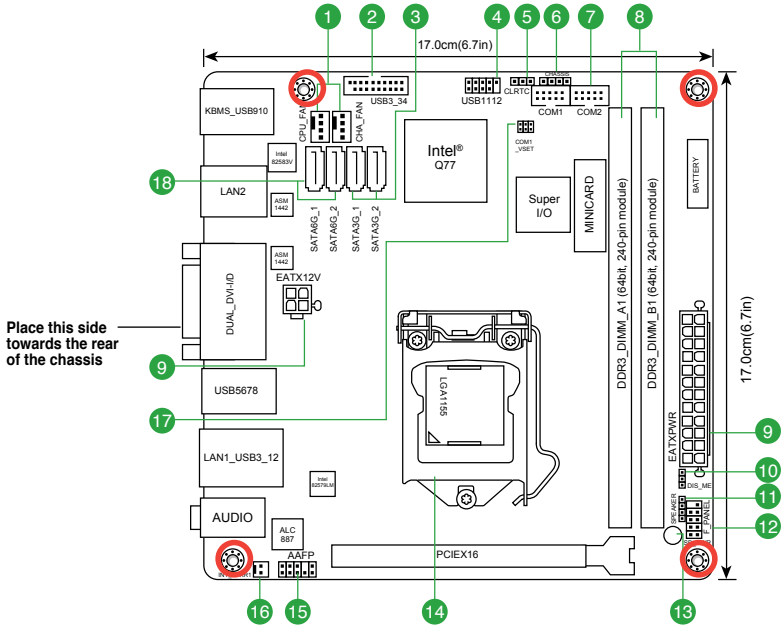

| Connectors/Jumpers/Slots  | Page |
|---|------|
| 1. CPU and system fan connectors (4-pin CPU_FAN, 4-pin CHA_FAN) | 2-20 |
| 2. USB 3.0 connector (20-1 pin USB3_34)                         | 2-24 |
| 3. Serial ATA 3.0Gb/s connectors (7-pin SATA3G_1, SATA3G_2)     | 2-23 |
| 4. USB 2.0 connector (10-1 pin USB1112)                         | 2-24 |
| 5. Clear RTC RAM (CLRTC)  | 2-13 |
| 6. Chassis intrusion connector (4-1 pin CHASSIS)                | 2-21 |
| 7. Serial port connectors (10-1 pin COM1, 10-1 COM2)            | 2-25 |
| 8. DIMM memory slots  | 2-11 |
| 9. ATX power connectors (24-pin EATXPWR, 4-pin EATX12V)         | 2-19 |
| 10. Intel® ME Jumper (3-pin DIS_ME)                             | 2-14 |
| 11. Speaker connector (4-pin SPEAKER)                           | 2-26 |
| 12. System panel connector (10-1 pin F_PANEL)                   | 2-22 |
| 13. Standby Power LED (SB_PWR LED)                              | 2-15 |
| 14. Intel® LGA1155 CPU socket                                   | 2-6  |
| 15. Front panel audio connector (10-1 pin AAFP)                 | 2-21 |
| 16. Internal monophonic speaker connector (2-pin INT_SPKR1)     | 2-26 |
| 17. COM1 Ring/+5V/+12V selection (COM1_VSET)                    | 2-14 |
| 18. Serial ATA 6.0Gb/s connectors (7-pin SATA6G_1, SATA6G_2)    | 2-23 |

## 2.3 Screw size

### 2.3.1 Component side

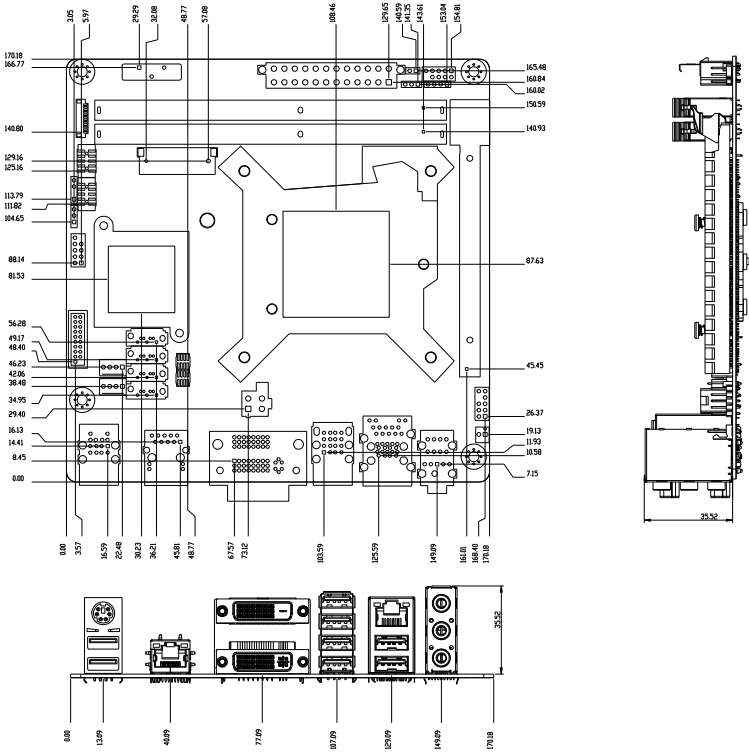

## 2.3.2 Solder side

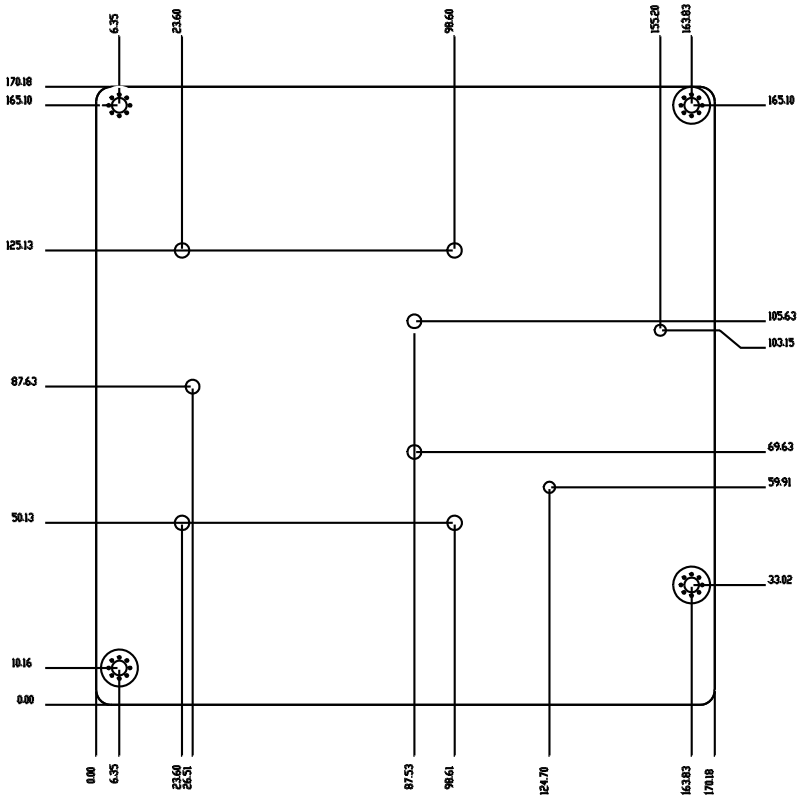

## 2.4 Central Processing Unit (CPU)

The motherboard comes with a surface mount LGA1155 socket designed for the Intel® 3rd/2nd Generation Core™ i7 / Core™ i5 / Core™ i3 / Pentium® / Celeron® processors.

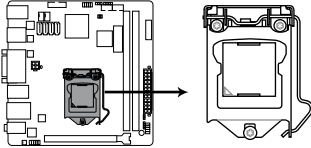

**EMB-Q77A CPU socket LGA1155**



---

**IMPORTANT:** Unplug all power cables before installing the CPU.

---



### **CAUTION!**

- Upon purchase of the motherboard, ensure that the PnP cap is on the socket and the socket contacts are not bent. Contact your retailer immediately if the PnP cap is missing, or if you see any damage to the PnP cap/socket contacts/motherboard components. The manufacturer will shoulder the cost of repair only if the damage is shipment/transit-related.
  - Keep the cap after installing the motherboard. The manufacturer will process Return Merchandise Authorization (RMA) requests only if the motherboard comes with the cap on the LGA1155 socket.
  - The product warranty does not cover damage to the socket contacts resulting from incorrect CPU installation/removal, or misplacement/loss/incorrect removal of the PnP cap.
-

## 2.4.1 Installing the CPU



**CAUTION!** The LGA1156 CPU is incompatible with the LGA1155 socket. DO NOT install a LGA1156 CPU on the LGA1155 socket.

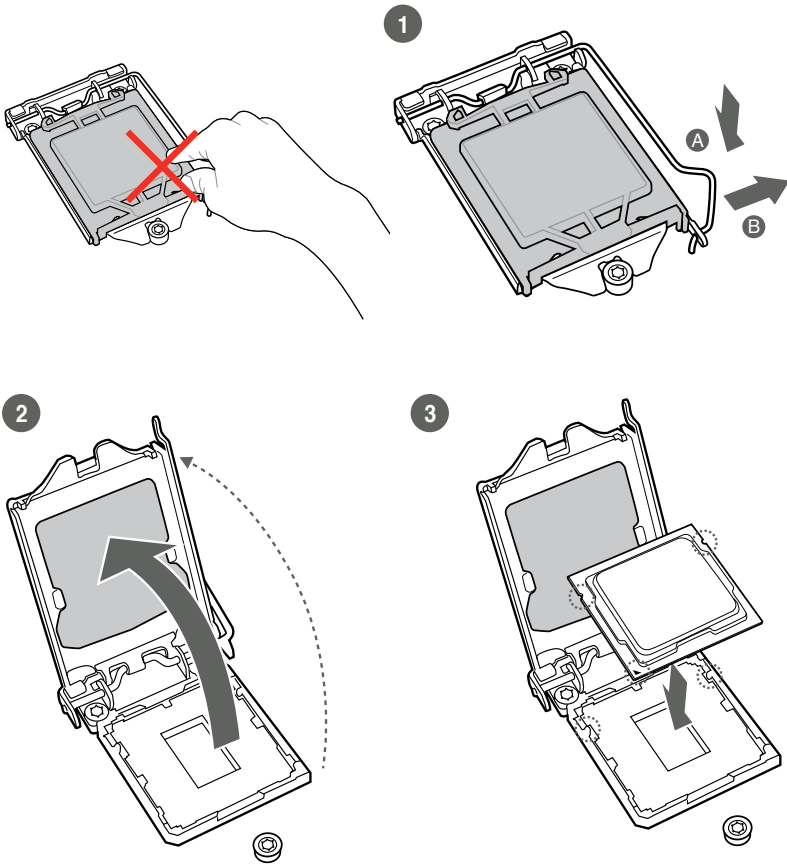

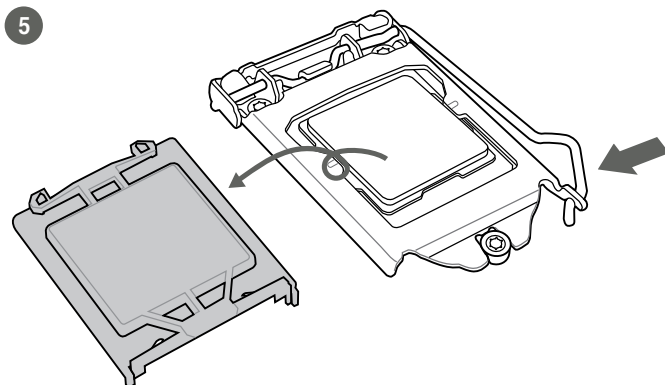
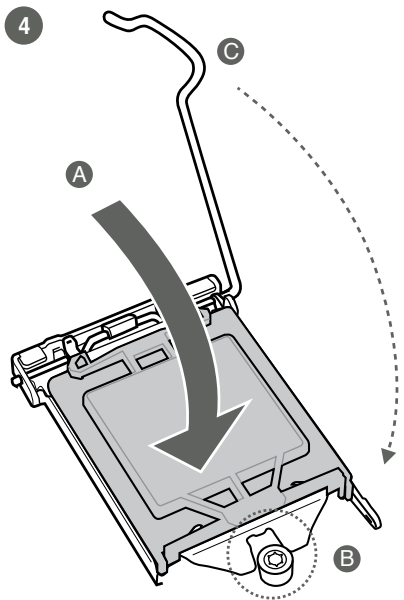



## 2.4.2 CPU heatsink and fan assembly installation

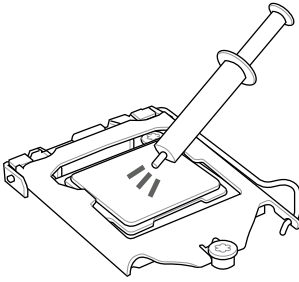

**CAUTION!** Apply the Thermal Interface Material to the CPU heatsink and CPU before you install the heatsink and fan if necessary.

To install the CPU heatsink and fan assembly

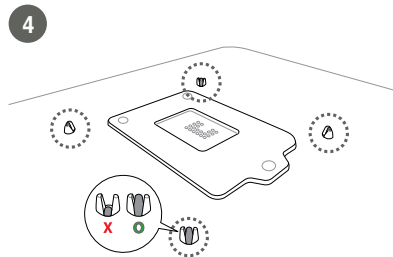
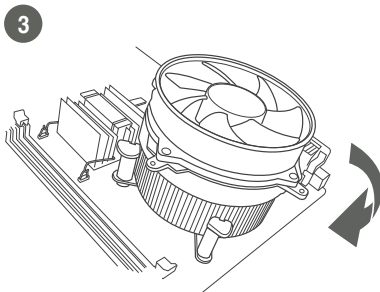
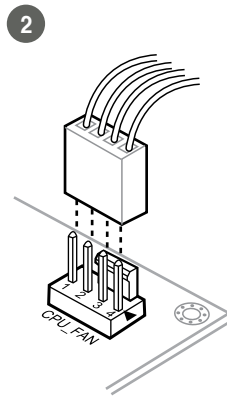
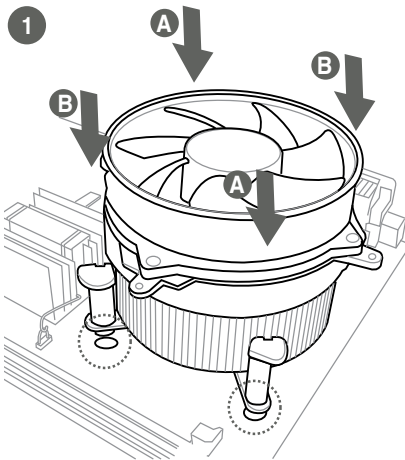

To uninstall the CPU heatsink and fan assembly

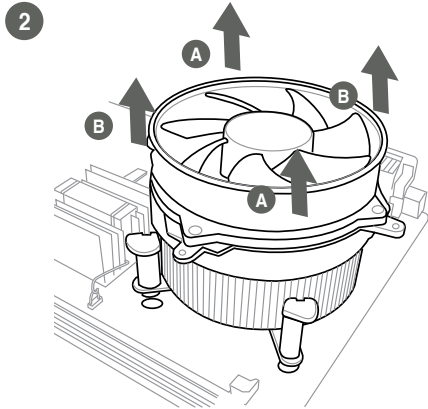
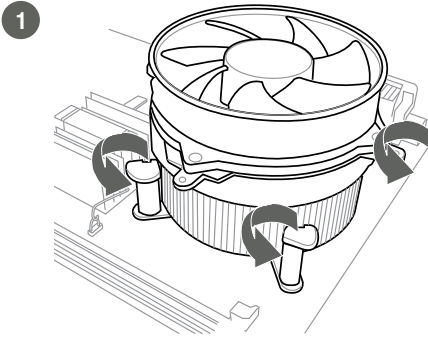

## 2.5 System memory

This motherboard comes with two Double Data Rate 3 (DDR3) Dual Inline Memory Module (DIMM) sockets. A DDR3 module has the same physical dimensions as a DDR2 DIMM but is notched differently to prevent installation on a DDR2 DIMM socket. DDR3 modules are developed for better performance with less power consumption.

The figure below illustrates the location of the DDR3 DIMM sockets:

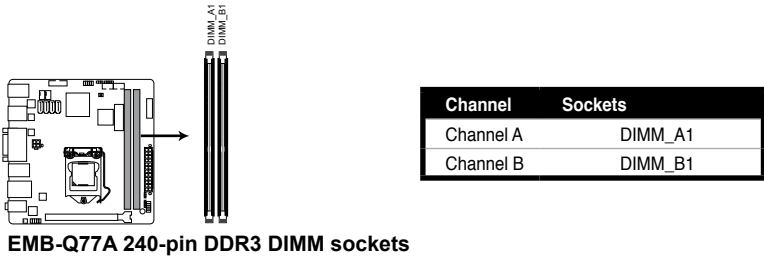

### 2.5.1 Installing a DIMM

1

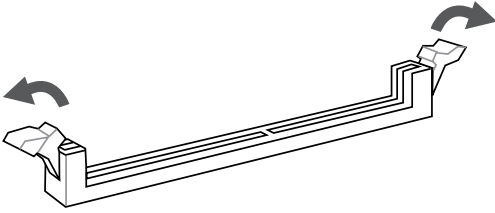

2

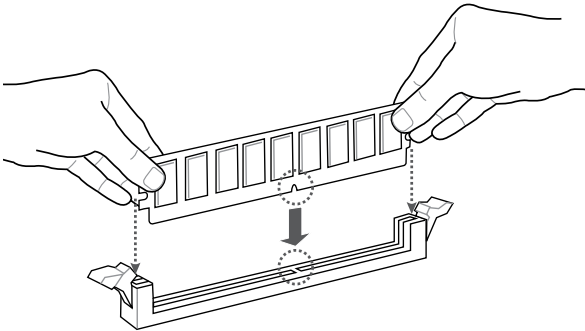

3

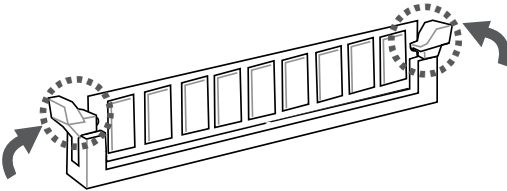

#### To remove a DIMM

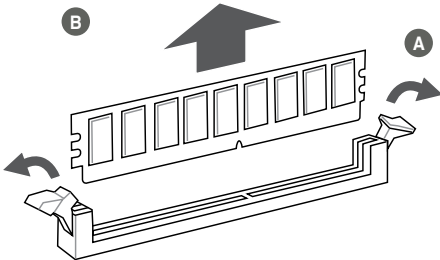

## 2.6 Jumpers

### 1. Clear RTC RAM (CLRTC)

This jumper allows you to clear the Real Time Clock (RTC) RAM in CMOS. You can clear the CMOS memory of system setup parameters by erasing the CMOS RTC RAM data. The onboard button cell battery powers the RAM data in CMOS, which include system setup information such as system passwords.

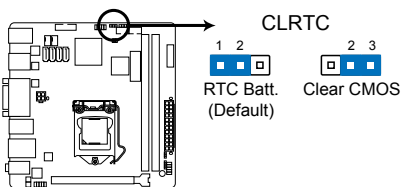

**EMB-Q77A Clear RTC RAM**

#### To erase the RTC RAM:

1. Turn OFF the computer and unplug the power cord.
2. Move the jumper cap from pins 1-2 (default) to pins 2-3. Keep the cap on pins 2-3 for about 5~10 seconds, then move the cap back to pins 1-2.
3. Plug the power cord and turn ON the computer.
4. Hold down the **<Del>** key during the boot process and enter BIOS setup to reenter data.



---

**CAUTION!** Except when clearing the RTC RAM, never remove the cap on CLRTC jumper default position. Removing the cap will cause system boot failure!

---



#### NOTES:

- If the steps above do not help, remove the onboard battery and move the jumper again to clear the CMOS RTC RAM data. After clearing the CMOS, reinstall the battery.
  - You do not need to clear the RTC when the system hangs due to overclocking. For system failure due to overclocking, use the CPU Parameter Recall (C.P.R) feature. Shut down and reboot the system so the BIOS can automatically reset parameter settings to default values.
-

### 2. Intel® ME Jumper (3-pin DIS\_ME)

This jumper allows you to force Intel® Management Engine (ME) boot from recovery mode when ME become corrupted.

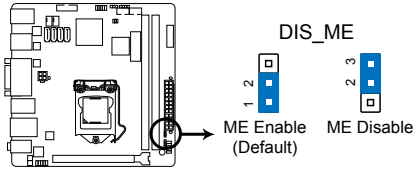

**EMB-Q77A Intel® ME jumper**

### 3. COM1 Ring/+5V/+12V selection (COM1\_VSET)

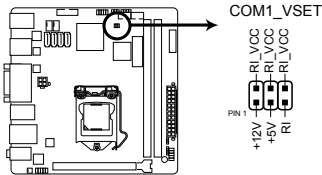

**EMB-Q77A COM VSET connector**

| Setting        | Pins |
|----------------|------|
| +12V           | 1-2  |
| +5V            | 3-4  |
| Ring (Default) | 5-6  |

## 2.7 Onboard LEDs

### 1. Standby Power LED

The motherboard comes with a standby power LED that lights up to indicate that the system is ON, in sleep mode, or in soft-off mode. This is a reminder that you should shut down the system and unplug the power cable before removing or plugging in any motherboard component. The illustration below shows the location of the onboard LED.

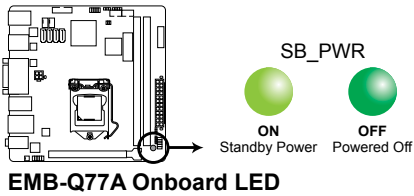

## 2.9 Connectors

### 2.9.1 Rear panel connectors

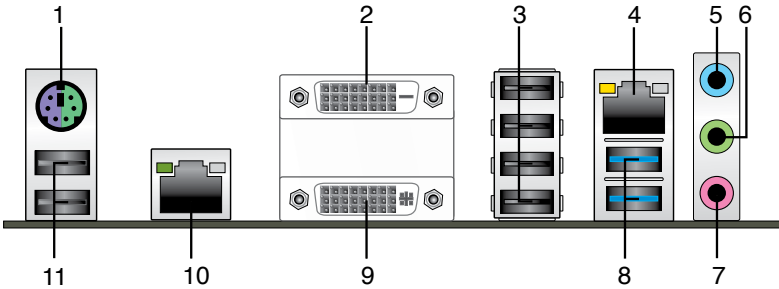

1. **PS/2 keyboard/mouse port (purple/green).** This port is for a PS/2 keyboard or mouse.
2. **DVI-D port.** This port is for any DVI-D compatible device. DVI-D can't be converted to output RGB signal to CRT and isn't compatible with DVI-I.
3. **USB 2.0 ports.** These four 4-pin Universal Serial Bus (USB) ports are available for connecting USB 2.0/1.1 devices.
4. **LAN1 (RJ-45) port.** These ports allow Gigabit connection to a Local Area Network (LAN) through a network hub. Refer to the table below for the LAN1 port LED indications.

#### LAN1 port LED indications

| ACT/LINK LED |               | SPEED LED |                     |
|--------------|---------------|-----------|---------------------|
| Status       | Description   | Status    | Description         |
| OFF          | No link       | OFF       | 10 Mbps connection  |
| ORANGE       | Linked        | ORANGE    | 100 Mbps connection |
| BLINKING     | Data activity | GREEN     | 1 Gbps connection   |

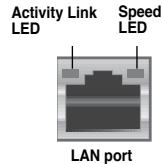



5. **Line In port (light blue).** This port connects the tape, CD, DVD player, or other audio sources.
6. **Line Out port (lime).** This port connects to a headphone or a speaker. In a 4-channel, 6-channel and 8-channel configurations, the function of this port becomes Front Speaker Out.
7. **Microphone port (pink).** This port connects a microphone.



**NOTE:** Refer to the audio configuration table below for the function of the audio ports in the 2, 4, 6 or 8-channel configuration.

#### Audio 2, 4, 6 or 8-channel configuration

| Port                    | Headset 2-channel | 4-channel         | 6-channel         | 8-channel         |
|-------------------------|-------------------|-------------------|-------------------|-------------------|
| Light Blue (Rear panel) | Line In           | Rear Speaker Out  | Rear Speaker Out  | Rear Speaker Out  |
| Lime (Rear panel)       | Line Out          | Front Speaker Out | Front Speaker Out | Front Speaker Out |
| Pink (Rear panel)       | Mic In            | Mic In            | Bass/Center       | Bass/Center       |
| Lime (Front panel)      | -                 | -                 | -                 | Side Speaker Out  |



#### To configure an 8-channel audio output:

Use a chassis with an HD audio module in the front panel to support an 8-channel audio output.

8. **USB 3.0 ports.** These two 9-pin Universal Serial Bus (USB) ports connect to USB 3.0/2.0 devices.



#### NOTES:

- DO NOT connect a keyboard / mouse to any USB 3.0 port when installing Windows® operating system.
- Due to USB 3.0 controller limitation, USB 3.0 devices can only be used under Windows® OS environment and after the USB 3.0 driver installation.
- USB 3.0 devices can only be used as data storage only.
- We strongly recommend that you connect USB 3.0 devices to USB 3.0 ports for faster and better performance for your USB 3.0 devices.

9. **DVI-I port.** This port is for any DVI-I and DVI-D compatible device. DVI-I can be converted to output RGB signal to CRT and is compatible with DVI-D.

10. **LAN2 (RJ-45) port.** These ports allow Gigabit connection to a Local Area Network (LAN) through a network hub. Refer to the table below for the LAN2 port LED indications.

**LAN2 port LED indications**

| ACT/LINK LED |               | SPEED LED |                     |
|--------------|---------------|-----------|---------------------|
| Status       | Description   | Status    | Description         |
| OFF          | No link       | OFF       | 10 Mbps connection  |
| GREEN        | Linked        | ORANGE    | 100 Mbps connection |
| BLINKING     | Data activity | GREEN     | 1 Gbps connection   |

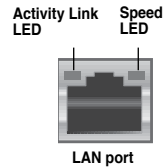

11. **USB 2.0 ports.** These two 4-pin Universal Serial Bus (USB) ports are available for connecting USB 2.0/1.1 devices.

## 2.9.2 Internal connectors

### 1. ATX power connectors (24-pin EATXPWR, 4-pin EATX12V)

These connectors are for ATX power supply plugs. The power supply plugs are designed to fit these connectors in only one orientation. Find the proper orientation and push down firmly until the connectors completely fit.

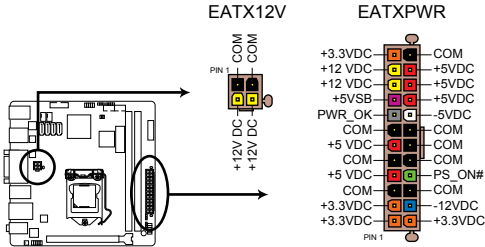

**EMB-Q77A ATX power connectors**



#### **IMPORTANT:**

- For a fully configured system, we recommend that you use a power supply unit (PSU) that complies with ATX 12 V Specification 2.0 (or later version) and provides a minimum power of 230W.
- DO NOT forget to connect the 4-pin ATX +12V power plug. Otherwise, the system will not have enough power.
- We recommend that you use a PSU with higher power output when configuring a system with more power-consuming devices. The system may become unstable or may not boot up if the power is inadequate.

## 2. CPU and chassis fan connectors (4-pin CPU\_FAN, 4-pin CHA\_FAN)

Connect the fan cables to the fan connectors on the motherboard, ensuring that the black wire of each cable matches the ground pin of the connector.

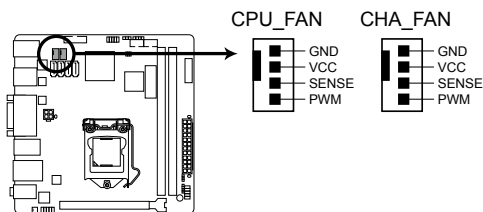

### EMB-Q77A CPU fan connector



---

**CAUTION:** Do not forget to connect the fan cables to the fan connectors. Insufficient air flow inside the system may damage the motherboard components. These are not jumpers! Do not place jumper caps on the fan connectors!

---



---

**NOTE:** The CPU\_FAN connector supports a CPU fan of maximum 2A (24 W) fan power.

---

### 3. Front panel audio connector (10-1 pin AAFP)

This connector is for a chassis-mounted front panel audio I/O module that supports either HD Audio or legacy AC'97 audio standard. Connect one end of the front panel audio I/O module cable to this connector.

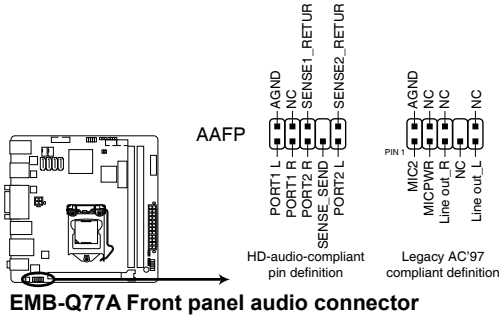

**EMB-Q77A Front panel audio connector**



#### IMPORTANT:

- We recommend that you connect a high-definition front panel audio module to this connector to avail of the motherboard's high-definition audio capability.
- If you want to connect a high-definition front panel audio module to this connector, set the Front Panel Type item in the BIOS setup to [HD]; if you want to connect an AC'97 front panel audio module to this connector, set the item to [AC97]. By default, this connector is set to [HD].

### 4. Chassis intrusion connector (4-1 pin CHASSIS)

This connector is for a chassis-mounted intrusion detection sensor or switch. Connect one end of the chassis intrusion sensor or switch cable to this connector. The chassis intrusion sensor or switch sends a high-level signal to this connector when a chassis component is removed or replaced. The signal is then generated as a chassis intrusion event.

By default, the pins labeled "Intruder" are shorted with a jumper cap. Remove the jumper caps only when you intend to use the chassis intrusion detection feature.

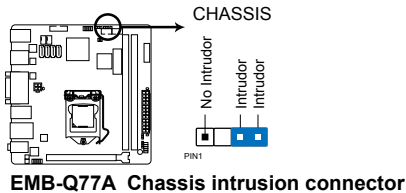

**EMB-Q77A Chassis intrusion connector**

**5. System panel connector (10-1 pin F\_PANEL)**

This connector supports several chassis-mounted functions.

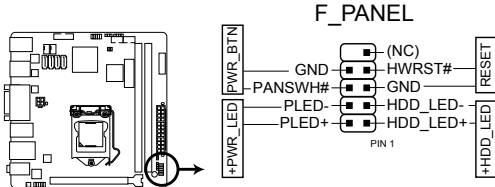

**EMB-Q77A System panel connector**

- **System power LED (2-pin PWR\_LED)**

This 2-pin connector is for the system power LED. Connect the chassis power LED cable to this connector. The system power LED lights up when you turn on the system power, and blinks when the system is in sleep mode.

- **Hard disk drive activity LED (2-pin HDD\_LED)**

This 2-pin connector is for the HDD Activity LED. Connect the HDD Activity LED cable to this connector. The HDD LED lights up or flashes when data is read from or written to the HDD.

- **ATX power button/soft-off button (2-pin PWR\_BTN)**

This 2-pin connector is for the system power button.

- **Reset button (2-pin RESET)**

This 2-pin connector is for the chassis-mounted reset button for system reboot without turning off the system power.

## 6. Serial ATA 3.0Gb/s connectors (7-pin SATA3G\_1, SATA3G\_2)

These connectors connect to Serial ATA 3.0 Gb/s hard disk drives and optical drives via Serial ATA 3.0 Gb/s signal cables.

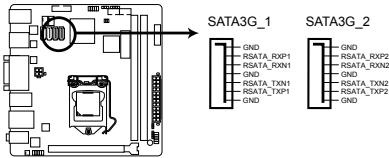

**EMB-Q77A SATA 3.0Gb/s connectors**



### NOTES:

- You must install Windows® XP Service Pack 3 or later version before using Serial ATA hard disk drives.
- When using hot-plug and NCQ, set the SATA Mode Selection item in the BIOS to [AHCI]. See section **3.3.4 SATA Configuration** for details.

## 7. Serial ATA 6.0Gb/s connector (7-pin SATA6G\_1, SATA6G\_2)

This connector connects to Serial ATA 6.0 Gb/s hard disk drives via Serial ATA 6.0 Gb/s signal cables.

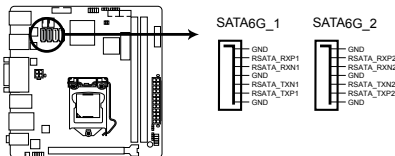

**EMB-Q77A SATA 6.0Gb/s connectors**



### NOTES:

- You must install Windows® XP Service Pack 3 or later version before using Serial ATA hard disk drives.
- When using hot-plug and NCQ, set the SATA Mode Selection item in the BIOS to [AHCI]. See section **3.3.3 SATA Configuration** for details.

## 8. USB 3.0 connector (20-pin USB3\_34)

These connectors allow you to connect a USB 3.0 module for additional USB 3.0 front panel ports. With an installed USB 3.0 module, you can enjoy all the benefits of USB 3.0 including faster data transfer speeds of up to 5Gbps, faster charging time for USB-chargeable devices, optimized power efficiency, and backward compatibility with USB 2.0.

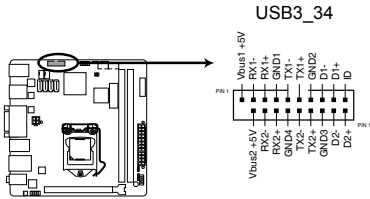

**EMB-Q77A USB3.0 Front panel connector**



---

### NOTES:

- The USB module cable is purchased separately.
  - Due to Intel® limitations, USB3\_34 is only supported in Windows® 7 operating systems.
-



## 9. USB 2.0 connector (10-1 pin USB1112)

This connector is for USB 2.0 ports. Connect the USB module cable to connector USB1112. This USB connector complies with USB 2.0 specification that supports up to 480 Mbps connection speed.

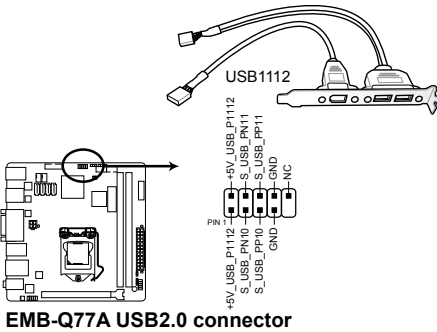

**EMB-Q77A USB2.0 connector**



---

Never connect a 1394 cable to the USB connector. Doing so will damage the motherboard.

---



---

The USB module cable is purchased separately.

---

## 10. Serial port connectors (10-1 pin COM1, COM2)

These connectors are for serial (COM) ports. Connect the serial port module cables to these connectors, then install the module to a slot opening at the back of the system chassis.

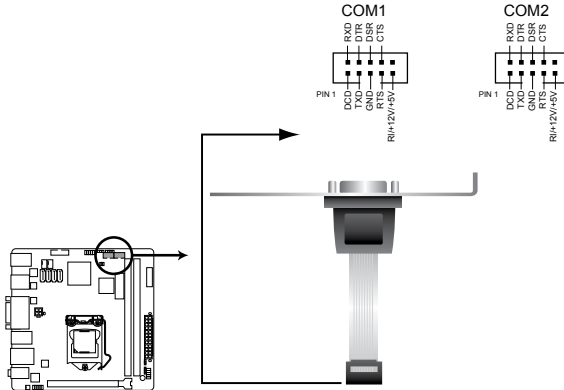

**EMB-Q77A Serial port connector**

| Pin | Signal                 | Pin | Signal        |
|-----|------------------------|-----|---------------|
| 1   | DCD (422TXD-/485DATA-) | 2   | RXD (422RXD+) |
| 3   | TXD (422TXD+/485DATA+) | 4   | DTR (422RXD-) |
| 5   | GND                    | 6   | DSR           |
| 7   | RTS                    | 8   | CTS           |
| 9   | RI/+12V/+5V            | 10  | N.C.          |



### NOTES:

- The COM module is purchased separately.
- Only COM1 can support RS-422 and RS-485.

### 11. Speaker connector (4-pin SPEAKER)

The 4-pin connector is for the chassis-mounted system warning speaker. The speaker allows you to hear system beeps and warnings.

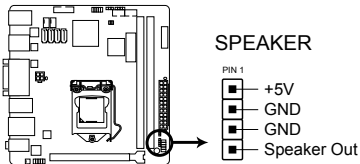

**EMB-Q77A Speaker Out Connector**

### 12. Minicard connector

Use this connector to connect a Minicard reader.

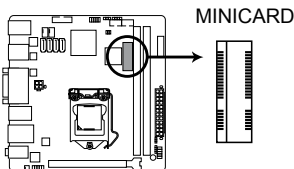

**EMB-Q77A MINICARD connector**

### 13. Internal monophonic speaker connector (2-pin INT\_SPKR1)

The internal mono speaker header allows connection to an internal, low-power speaker for basic system sound capability. The subsystem is capable of driving a speaker load of 4 Ohms at 2 Watts (rms).

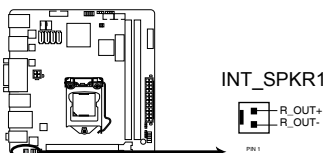

**EMB-Q77A INT\_SPKR connector**

---

---

---

---

---

---

---

---

---

---

---

---

---

---

---

---

---

---

---

---

---

---

---

---

---

---

---

---

---

---

# Chapter 3

## BIOS setup

### 3.1 BIOS setup program

Use the BIOS Setup program to update the BIOS or configure its parameters. The BIOS screens include navigation keys and brief online help to guide you in using the BIOS Setup program.

#### Entering BIOS Setup at startup

##### To enter BIOS Setup at startup:

Press <Delete> during the Power-On Self Test (POST). If you do not press <Delete>, POST continues with its routine.

#### Entering BIOS Setup after POST

##### To enter BIOS Setup after POST:

- Press <Ctrl>+<Alt>+<Del> simultaneously.
- Press the reset button on the system chassis.
- Press the power button to turn the system off then back on. Do this option only if you failed to enter BIOS Setup using the first two options.



---

**NOTE:** Using the power button, reset button, or the <Ctrl>+<Alt>+<Del> keys to reboot a running operating system can cause damage to your data or system. Always shut down the system properly from the operating system.

---



---

#### IMPORTANT:

- The default BIOS settings for this motherboard apply to most working conditions and ensures optimal performance. If the system becomes unstable after changing any BIOS settings, load the default settings to regain system stability. Select the option **Restore Defaults** under the Save & Exit Menu. See section **3.7 Exit Menu**.
  - The BIOS setup screens shown in this section are for reference purposes only, and may not exactly match what you see on your screen.
-

### 3.1.1 BIOS menu screen



### 3.1.2 Menu bar

The menu bar on top of the screen has the following main items:

- Main** For changing the basic system configuration.
- Advanced** For changing the advanced system settings.
- Monitor** For viewing and changing fan and voltage information.
- Boot** For changing the system boot configuration.
- Tool** For updating the BIOS and viewing DRAM SPD Information.
- Exit** For selecting the exit options and loading default settings.

To select an item on the menu bar, press the right or left arrow key on the keyboard until the desired item is highlighted.

## 3.2 Main menu

The Main menu provides you an overview of the basic system information, and allows you to set the system date, time, language, and security settings.

### 3.2.1 System Language [English]

System language default is set to English.

### 3.2.2 System Date [Day MM/DD/YYYY]

Allows you to set the system date.

### 3.2.3 System Time [HH:MM:SS]

Allows you to set the system time.

### 3.2.4 Security

The Security menu items allow you to change the system security settings.



- 
- If you have forgotten your BIOS password, erase the CMOS Real Time Clock (RTC) RAM to clear the BIOS password. See section **2.6 Jumpers** for information on how to erase the RTC RAM.
  - The **Administrator** or **User Password** items on top of the screen show the default **Not Installed**. After you set a password, these items show **Installed**.
-

### 3.3 Advanced menu

The Advanced menu items allow you to change the settings for the CPU and other system devices.



Be cautious when changing the settings of the Advanced menu items. Incorrect field values can cause the system to malfunction.



#### 3.3.1 Trusted Computing

This item appears only when a TPM module is connected to the motherboard and allows you to change TPM settings.

##### **TPM Support [Enabled]**

Allows you to enable or disable TPM support. Configuration options: [Disabled] [Enabled]

##### **TPM State [Enabled]**

Allows you to enable or disable security devices. Configuration options: [Disabled] [Enabled]



### 3.3.2 CPU Configuration

The items in this menu show the CPU-related information that the BIOS automatically detects.



---

The items shown in the submenu may be different due to the CPU installed.

---

#### **Active Processor Cores [All]**

Allows you to choose the number of CPU cores to activate in each processor package. Configuration options: [All] [1] [2] [3]



---

Configuration options for active processor cores are dependent on the installed CPU.

---

#### **Active Processor Cores [All]**

##### **Intel Virtualization Technology [Disabled]**

[Enabled]

Allows a hardware platform to run multiple operating systems separately and simultaneously, enabling one system to virtually function as several systems.

[Disabled]

Disables this function.

### 3.3.3 SATA Configuration

While entering Setup, the BIOS automatically detects the presence of SATA devices. The SATA Port items show **Not Present** if no SATA device is installed to the corresponding SATA port.

#### SATA Mode Selection [AHCI]

Allows you to set the SATA configuration.

- [Disabled] Disables the SATA function.
- [IDE] Set to [IDE] when you want to use the Serial ATA hard disk drives as Parallel ATA physical storage devices.
- [AHCI] Set to [AHCI] when you want the SATA hard disk drives to use the AHCI (Advanced Host Controller Interface). The AHCI allows the onboard storage driver to enable advanced Serial ATA features that increases storage performance on random workloads by allowing the drive to internally optimize the order of commands.
- [RAID] Set to [RAID] when you want to create a RAID configuration from the SATA hard disk drives.

#### Hot Plug [Disabled] (SATA6G\_1 ~ SATA6G\_2; SATA3G\_1 ~ SATA3G\_2; mSATA)

These items appear only when you set the SATA Mode Selection item to [AHCI] or [RAID], and allow you to enable/disable SATA Hot Plug Support.

Configuration options: [Disabled] [Enabled]

### 3.3.4 System Agent Configuration

#### VT-d [Disabled]

Allows you to enable virtualization technology function on memory control hub.

[Enabled] Enables the function.

[Disabled] Disables this function.

#### Graphics Configuration

##### Primary Display [Auto]

Allows you to decide which graphics controller to use as the primary boot device. Configuration options: [Auto] [iGPU] [PCIE]

##### iGPU Memory [Auto]

Allows you to select the amount of system memory allocated to DVMT 5.0 used by the iGPU. Configuration options: [32M] [64M] [96M] [128M] ~ [416M] [448M] [480M] [1024M]

##### iGPU Multi-Monitor [Disabled]

Allows you to enable or disable the iGPU Multi-Monitor. For Lucid Virtu Universal MVP function support, set this item to [Enabled] to empower both the integrated and discrete graphic cards. The iGPU shared memory size will be fixed at 64MB. Configuration options: [Disabled] [Enabled]

#### NB PCIe Configuration

Allows you to configure the NB PCI Express settings.

##### PCIEx16\_1 Link Speed [Auto]

Allows you to configure the PCIEx16 speed. Configuration options: [Auto] [Gen1] [Gen2]

### 3.3.5 Intel TXT(LT) Configuration

Allows you to enable/disable Intel Trusted Execution Technology support.

#### Secure Mode Extensions (SMX)

- [Enabled] Enables Secure Mode Extensions.
- [Disabled] Disables Secure Mode Extensions.

#### Intel TXT(LT) Support

- [Enabled] Enables support for Intel Trusted Execution Technology.
- [Disabled] Disables support for Intel Trusted Execution Technology.



---

To enable **Intel TXT(LT) Support**, SMX and VT-d items should also be enabled.

---

### 3.3.6 AMT Configuration

The items in this menu allow you to change the Intel® Active Management Technology (AMT) feature.

#### Intel® AMT [Enabled]

Allow you to enable or disable the Intel® Active Management Technology (AMT) in the BIOS extension. Configuration options: [Enabled] [Disabled]



- iAMT H/W is always enabled. This option just controls the BIOS extension execution. If enabled, this requires additional firmware in the SPI device.
  - The following two items become configurable only when you set the Intel®AMT item to [Enabled].
- 

#### Invoke MEBx [Disabled]

This item become configurable only when the previous item is set to [Enabled] and allows you to enable or disable this function. Configuration options: [Enabled] [Disabled]

#### Un-Configure ME [Disabled]

Sets this item to [Disabled] to unconfigure AMT/ME without using a password or set it to [Enabled] to use a password. Configuration options: [Enabled] [Disabled]

### 3.3.7 USB Configuration

The items in this menu allow you to change the USB-related features.



---

The USB Devices item shows the auto-detected values. If no USB device is detected, the item shows **None**.

---

#### **Intel USB2.0 EHCI Controller [Enabled]**

[Enabled] Enables USB2.0 EHCI Controller.

[Disabled] Disables USB2.0 EHCI Controller.

#### **Legacy USB Support [Enabled]**

[Enabled] Enables the support for USB devices on legacy operating systems (OS).

[Disabled] The USB devices can be used only for the BIOS setup program.

[Auto] Allows the system to detect the presence of USB devices at startup. If detected, the USB controller legacy mode is enabled. If no USB device is detected, the legacy USB support is disabled.

#### **Legacy USB3.0 Support [Enabled]**

[Enabled] Enables the support for USB 3.0 devices on legacy operating systems (OS).

[Disabled] Disables the function.

[Disabled] Disables the function.

### 3.3.8 Onboard Devices Configuration

#### HD Audio Controller [Enabled]

[Enabled] Enables the High Definition Audio Controller.

[Disabled] Disables the controller.



---

The following two items appear only when you set the **HD Audio Controller** item to [Enabled].

---

#### Front Panel Type [HD]

Allows you to set the front panel audio connector (AAFP) mode to legacy AC'97 or high-definition audio depending on the audio standard that the front panel audio module supports.

[HD] Sets the front panel audio connector (AAFP) mode to high definition audio.

[AC97] Sets the front panel audio connector (AAFP) mode to legacy AC'97

#### Intel 82579LM LAN Controller [Enabled]

[Enabled] Enables the Intel LAN controller.

[Disabled] Disables the controller.

#### Intel 82583V LAN Controller [Enabled]

[Enabled] Enables the Intel LAN controller.

[Disabled] Disables the controller.

#### Intel 82579LM PXE OPROM [Disabled]

This item appears only when you set the Intel 82579LM LAN Controller item to [Enabled] and allows you to enable or disable the PXE OptionRom of the Intel LAN controller.

Configuration options: [Enabled] [Disabled]

#### Intel 82583V PXE OPROM [Disabled]

This item appears only when you set the Intel 82583V LAN Controller item to [Enabled] and allows you to enable or disable the PXE OptionRom of the Intel LAN controller.

Configuration options: [Enabled] [Disabled]

## **Serial Port1~2 (COM1~COM2) Configuration**

The sub-items in this menu allow you to set the serial port configuration.

### **Serial Port [Enabled]**

Allows you to enable or disable the serial port (COM).

Configuration options: [Enabled] [Disabled]

### **RS Mode [RS232]**

Allows you to select COM RS Mode.

Configuration options: [RS232] [RS422] [RS485]

### **Change Settings [IO=3F8h; IRQ=4]**

Allows you to select the Serial Port base address.

Configuration options:

[IO=3F8h; IRQ=4] [IO=2F8h; IRQ=3] [IO=3E8h; IRQ=4] [IO=2E8h; IRQ=3]

### 3.3.9 APM

#### AT/ATX Power Type [ATX Mode]

Select AT or ATX Power Type.

Configuration options: [AT Mode] [ATX Mode]

#### Intel vPro Preparation Requirements [Unsupported]

Enable/disable support for Intel vPro.

Configuration options: [Unsupported] [Supported]

#### Restore AC Power Loss [Power Off]

- [Power On] The system goes into on state after an AC power loss.
- [Power Off] The system goes into off state after an AC power loss.
- [Last State] The system goes into either off or on state, whatever the system state was before the AC power loss.

#### Power On By PCIE [Disabled]

- [Disabled] Disables the Wake-on-LAN feature of all onboard LAN controllers and installed PCIe LAN devices.
- [Enabled] Enables Wake-on-LAN feature for all onboard LAN controllers and installed PCIe LAN devices.

#### Power On By Ring [Disabled]

- [Disabled] Disables Ring to generate a wake event.
- [Enabled] Enables Ring to generate a wake event.

#### Power On By RTC [Disabled]

- [Disabled] Disables RTC to generate a wake event.
- [Enabled] When set to [Enabled], the items **RTC Alarm Date (Days)** and **Hour/Minute/Second** will become user-configurable with set values.



### 3.3.10 Network Stack

#### Network Stack [Disabled]

This item allows user to disable or enable the UEFI network stack. Configuration options: [Disabled] [Enabled]



---

The following two items appear only when you set the previous item to [Enabled].

---

#### Ipv4 PXE Support [Enabled]

This item allows user to disable or enable the Ipv4 PXE Boot support. Configuration options: [Disable Link] [Enable]

#### Ipv6 PXE Support [Enabled]

This item allows user to disable or enable the Ipv6 PXE Boot support. Configuration options: [Disable Link] [Enable]

## 3.4 Monitor menu

The Monitor menu displays the system temperature/power status, and allows you to change the fan settings.



### 3.4.1 CPU Temperature / MB Temperature [xxx°C/xxx°F]

The onboard hardware monitor automatically detects and displays the CPU and motherboard temperatures. Select **Ignore** if you do not wish to display the detected temperatures.

### 3.4.2 CPU / Chassis Fan Speed [xxxx RPM] or [Ignore] / [N/A]

The onboard hardware monitor automatically detects and displays the CPU and chassis fan speeds in rotations per minute (RPM). If the fan is not connected to the motherboard, the field shows **N/A**. Select **Ignore** if you do not wish to display the detected speed.

### 3.4.3 CPU Q-Fan Control [Enabled]

[Disabled] Disables the CPU Q-Fan control feature.

[Enabled] Enables the CPU Q-Fan control feature.

#### CPU Fan Speed Low Limit [200 RPM]

This item appears only when you enable the CPU Q-Fan Control feature and allows you to disable or set the CPU fan warning speed. Configuration options: [Ignore] [100 RPM] [200 RPM] [300 RPM] [400 RPM] [500 RPM]

#### CPU Fan Profile [Standard]

This item appears only when you enable the CPU Q-Fan Control feature and allows you to set the appropriate performance level of the CPU fan.

[Standard] Sets to [Standard] to make the CPU fan automatically adjust depending on the CPU temperature.

[Silent] Sets to [Silent] to minimize the fan speed for quiet CPU fan operation.

[Turbo] Sets to [Turbo] to achieve maximum CPU fan speed.

[Manual] Sets to [Manual] to assign detailed fan speed control parameters.



---

The following four items appear only when you set CPU Fan Profile to [Manual].

---

#### CPU Upper Temperature [70]

Use the <+> and <-> keys to adjust the upper limit of the CPU temperature. The values range from 20°C to 75°C.

#### CPU Fan Max. Duty Cycle(%) [100]

Use the <+> and <-> keys to adjust the maximum CPU fan duty cycle. The values range from 20% to 100%. When the CPU temperature reaches the upper limit, the CPU fan will operate at the maximum duty cycle.

#### CPU Lower Temperature [20]

Displays the lower limit of the CPU temperature.

#### CPU Fan Min. Duty Cycle(%) [20]

Use the <+> and <-> keys to adjust the minimum CPU fan duty cycle. The values range from 0% to 100%. When the CPU temperature is under 40°C, the CPU fan will operate at the minimum duty cycle.

### Chassis Q-Fan Control [Enabled]

- [Disabled] Disables the Chassis Q-Fan control feature.
- [Enabled] Enables the Chassis Q-Fan control feature.

### Chassis Fan Speed Low Limit [600 RPM]

This item appears only when you enable the **Chassis Q-Fan Control** feature and allows you to disable or set the chassis fan warning speed.

Configuration options: [Ignore] [200 RPM] [300 RPM] [400 RPM] [500 RPM] [600 RPM]

### Chassis Fan Profile [Standard]

This item appears only when you enable the **Chassis Q-Fan Control** feature and allows you to set the appropriate performance level of the chassis fan.

- [Standard] Sets to [Standard] to make the chassis fan automatically adjust depending on the chassis temperature.
- [Silent] Sets to [Silent] to minimize the fan speed for quiet chassis fan operation.
- [Turbo] Sets to [Turbo] to achieve maximum chassis fan speed.
- [Manual] Sets to [Manual] to assign detailed fan speed control parameters.



---

The following four items appear only when you set **Chassis Fan Profile** to [Manual].

---

### Chassis Upper Temperature [70]

Use the <+> and <-> keys to adjust the upper limit of the CPU temperature. The values range from 40°C to 90°C.

### Chassis Fan Max. Duty Cycle(%) [100]

Use the <+> and <-> keys to adjust the maximum chassis fan duty cycle. The values range from 60% to 100%. When the chassis temperature reaches the upper limit, the chassis fan will operate at the maximum duty cycle.

### Chassis Lower Temperature [40]

Displays the lower limit of the chassis temperature.

#### **CPU Fan Min. Duty Cycle(%) [60]**

Use the <+> and <-> keys to adjust the minimum chassis fan duty cycle. The values range from 60% to 100%. When the chassis temperature is under 40°C, the chassis fan will operate at the minimum duty cycle.

### **3.4.4 CPU Voltage, 3.3V Voltage, 5V Voltage, 12V Voltage**

The onboard hardware monitor automatically detects the voltage output through the onboard voltage regulators. Select **Ignore** if you do not want to detect this item.

### 3.5 Boot menu

The Boot menu items allow you to change the system boot options.



#### 3.5.1 Fast Boot [Enabled]

Enable or disable boot with initialization of a minimal set of devices to launch active boot option. Configuration options: [Disabled] [Enabled]



The following three items appear only when you set **Fast Boot** to [Enabled].

#### USB Support [Partial Initial]

- [Disabled] All USB devices will not be available until after OS boot.
- [Full Initial] All USB devices will be available in OS and during POST.
- [Partial Initial] Specific USB port/device will not be available before OS boot.

### **PS/2 Keyboard and Mouse Support [Auto]**

- [Auto] Automatic configuration.
- [Disabled] Disables PS/2 keyboard and mouse support during POST.
- [Full Initialization] PS/2 keyboard and mouse support are enabled during POST.

### **Network Stack Driver Support [Disabled]**

- [Disabled] The BIOS skips over the Network Stack Driver and tries to boot from the next device.
- [Enabled] Allows the BIOS to boot from the Network Stack Driver.

### **3.5.2 Bootup NumLock State [On]**

- [On] Sets the power-on state of the NumLock to [On].
- [Off] Sets the power-on state of the NumLock to [Off].

### **3.5.3 Wait for 'F1' If Error [Disabled]**

When this item is set to [Enabled], the system waits for the F1 key to be pressed when error occurs. Configuration options: [Disabled] [Enabled]

### **3.5.4 Option ROM Messages [Force BIOS]**

- [Force BIOS] The third-party ROM messages will be forced to display during the boot sequence.
- [Keep Current] The third-party ROM messages will be displayed only if the third-party manufacturer had set the add-on device to do so.

### **3.5.5 INT19 Trap Response [Postponed]**

- [Immediate] Execute INT19 Trap immediately.
- [Postponed] Execute INT19 Trap during legacy boot.

### 3.5.6 CSM (Compatibility Support Module)

This option controls whether or not CSM will be launched.

#### Launch CSM [Enabled]

Configuration option: [Auto] [Enabled] [Disabled]



---

The following four items appear only when you set **Launch CSM** to [Enabled].

---

#### Boot Device Control [UEFI and Legacy OpROM]

Configuration option: [UEFI and Legacy OpROM] [Legacy OpROM only] [UEFI only]

#### Boot from Network Devices [Legacy OpROM first]

Configuration option: [Legacy OpROM first] [UEFI driver first] [Ignore]

#### Boot from Storage Devices [Legacy OpROM first]

Configuration option: [Both, Legacy OpROM first] [Both, UEFI first] [Legacy OpROM first] [UEFI driver first] [Ignore]

#### Boot from PCIe/PCI Expansion Devices [Legacy OpROM first]

Configuration option: [Legacy OpROM first] [UEFI driver first]

### 3.5.7 Secure Boot

This option allows you to configure the Secure Boot related parameters.

#### OS Type [Windows UEFI mode]

Configuration options: [Windows UEFI mode] [Other OS]

#### Key Management

##### Clear Secure Boot keys

Configuration options: [Yes] [No]

##### Save Secure Boot keys

Configuration options: [OK]



## **Save Secure Boot keys**

### **Platform Key (PK) Management**

**Delete PK**

Configuration options: [Yes] [No]

**Load PK from File**

### **Key Exchange Key (KEK) Management**

**Delete the KEK**

Configuration options: [Yes] [No]

**Load KEK from File**

**Append KEK from File**

### **Database (DB) Management**

**Delete the DB**

Configuration options: [Yes] [No]

**Load DB from File**

**Append DB from File**

### **DBX Management**

**Delete the DBX**

Configuration options: [Yes] [No]

**Load DBX from File**

**Append DBX from File**

### 3.5.8 Boot Option Priorities

These items specify the boot device priority sequence from the available devices. The number of device items that appears on the screen depends on the number of devices installed in the system.



- 
- To select the boot device during system startup, press <F8> when ASUS Logo appears.
  
  - To access Windows OS in Safe Mode, do any of the following:
    - Press <F5> when ASUS Logo appears.
    - Press <F8> after POST.
- 

### 3.5.9 Boot Override

These items displays the available devices. The number of device items that appears on the screen depends on the number of devices installed in the system. Click an item to start booting from the selected device.

## 3.6 Tools menu

The Tools menu items allow you to configure options for special functions. Select an item then press <Enter> to display the submenu.



### 3.6.1 EZ Flash 2 Utility

Allows you to run EZ Flash 2. Press [Enter] to launch the EZ Flash 2 screen.

### 3.6.2 DRAM SPD Information

#### DIMM Slot # [DIMM\_A1]

Displays the Serial Presence Detect (SPD) information of the DIMM module installed on the selected slot. Configuration options: [DIMM\_A1] [DIMM\_B1]

## 3.7 Exit menu

The Exit menu items allow you to load the optimal default values for the BIOS items, and save or discard your changes to the BIOS items. You can access the EZ Mode from the Exit menu.



### Load Optimized Defaults

This option allows you to load the default values for each of the parameters on the Setup menus. When you select this option or if you press <F5>, a confirmation window appears. Select Yes to load the default values.

### Save Changes & Reset

Once you are finished making your selections, choose this option from the Exit menu to ensure the values you selected are saved. When you select this option or if you press <F10>, a confirmation window appears. Select Yes to save changes and exit.

### Discard Changes & Exit

This option allows you to exit the Setup program without saving your changes. When you select this option or if you press <Esc>, a confirmation window appears. Select Yes to discard changes and exit.

### Launch EFI Shell from filesystem device

This option allows you to attempt to launch the EFI Shell application (shellx64.efi) from one of the available devices that have a filesystem.

# Appendix

## Notices

### Federal Communications Commission Statement

This device complies with Part 15 of the FCC Rules. Operation is subject to the following two conditions:

- This device may not cause harmful interference.
- This device must accept any interference received including interference that may cause undesired operation.

This equipment has been tested and found to comply with the limits for a Class A digital device, pursuant to Part 15 of the FCC Rules. These limits are designed to provide reasonable protection against harmful interference in a residential installation. This equipment generates, uses and can radiate radio frequency energy and, if not installed and used in accordance with manufacturer's instructions, may cause harmful interference to radio communications. However, there is no guarantee that interference will not occur in a particular installation. If this equipment does cause harmful interference to radio or television reception, which can be determined by turning the equipment off and on, the user is encouraged to try to correct the interference by one or more of the following measures:

- Reorient or relocate the receiving antenna.
- Increase the separation between the equipment and receiver.
- Connect the equipment to an outlet on a circuit different from that to which the receiver is connected.
- Consult the dealer or an experienced radio/TV technician for help.



---

**WARNING!** The use of shielded cables for connection of the monitor to the graphics card is required to assure compliance with FCC regulations. Changes or modifications to this unit not expressly approved by the party responsible for compliance could void the user's authority to operate this equipment.

---



---

DO NOT throw the motherboard in municipal waste. This product has been designed to enable proper reuse of parts and recycling. This symbol of the crossed out wheeled bin indicates that the product (electrical and electronic equipment) should not be placed in municipal waste. Check local regulations for disposal of electronic products.

---



---

DO NOT throw the mercury-containing button cell battery in municipal waste. This symbol of the crossed out wheeled bin indicates that the battery should not be placed in municipal waste.

---



電子信息產品污染控制標示：圖中之數字為產品之環保使用期限。僅指電子信息產品中含有的有毒有害物質或元素不致發生外洩或突變從而對環境造成污染或對人身、財產造成嚴重損害的期限。

**有毒有害物質或元素的名稱及含量說明標示：**

| 部件名稱        | 有害物質或元素 |        |        |                   |                  |                     |
|-------------|---------|--------|--------|-------------------|------------------|---------------------|
|             | 鉛 (Pb)  | 汞 (Hg) | 鎘 (Cd) | 六 價 鉻<br>(Cr(VI)) | 多 溴 聯 苯<br>(PBB) | 多 溴 二 苯 醚<br>(PBDE) |
| 印刷電路板及其電子組件 | ×       | ○      | ○      | ○                 | ○                | ○                   |
| 外部信號連接頭及線材  | ×       | ○      | ○      | ○                 | ○                | ○                   |

○：表示該有毒有害物質在該部件所有均質材料中的含量均在 SJ/T 11363-2006 標準規定的限量要求以下。

×

×：表示該有毒有害物質至少在該部件的某一均質材料中的含量超出 SJ/T 11363-2006 標準規定的限量要求，然該部件仍符合歐盟指令 2002/95/EC 的規範。

備註：此產品所標示之環保使用期限，係指在一般正常使用狀況下。