

EPC-CV1 Series

Industrial Motherboard

Copyright Notice

This document is copyrighted, 2013. All rights are reserved. The original manufacturer reserves the right to make improvements to the products described in this manual at any time without notice.

No part of this manual may be reproduced, copied, translated, or transmitted in any form or by any means without the prior written permission of the original manufacturer. Information provided in this manual is intended to be accurate and reliable. However, the original manufacturer assumes no responsibility for its use, or for any infringements upon the rights of third parties that may result from its use. The material in this document is for product information only and is subject to change without notice. While reasonable efforts have been made in the preparation of this document to assure its accuracy, the original manufacturer assumes no liabilities resulting from errors or omissions in this document, or from the use of the information contained herein.

The original manufacturer reserves the right to make changes in the product design without notice to its users.

Acknowledgments

All other products' name or trademarks are properties of their respective owners.

- AMI is a trademark of American Megatrends Inc.
- Intel®, Core™ are trademarks of Intel® Corporation.
- Microsoft Windows® is a registered trademark of Microsoft Corp.
- ITE is a trademark of Integrated Technology Express, Inc.
- IBM, PC/AT, PS/2, and VGA are trademarks of International Business Machines Corporation.

The original manufacturer reserves the right to make changes in the product design without notice to its users.

All other product names or trademarks are properties of their respective owners.

Contents

Chapter 1: Product overview

1.1	Package contents.....	1-1
1.2	Features	1-1
1.3	Specifications.....	1-2

Chapter 2: Motherboard information

2.1	Before you proceed	2-1
2.2	Motherboard layout.....	2-2
2.3	Screw size.....	2-4
	2.3.1 Component side.....	2-4
	2.3.2 Solder side	2-5
2.4	Central Processing Unit (CPU)	2-6
2.5	System memory	2-6
2.6	Jumpers	2-8
2.7	Connectors	2-12
	2.7.1 Rear panel connectors.....	2-12
	2.7.2 Internal connectors	2-13

Chapter 3: BIOS setup

3.1	BIOS setup program	3-1
3.2	BIOS menu screen	3-2
3.3	Main menu	3-4
	3.3.1 System Language [English]	3-4
	3.3.2 System Date [Day xx/xx/xxxx].....	3-4
	3.3.3 System Time [xx:xx:xx]	3-4
	3.3.4 Security	3-4
3.4	Advanced menu	3-6
	3.4.1 CPU Configuration	3-6
	3.4.2 IDE Configuration.....	3-7
	3.4.3 USB Configuration	3-7
	3.4.4 APM	3-7
	3.4.5 Panel Controller (AMD® GPU only).....	3-8
	3.4.6 DIO Function.....	3-8
	3.4.7 North Bridge LVDS Config Select (AMD® GPU only)	3-8
	3.4.8 Onboard Devices Configuration.....	3-8

Contents

- 3.5 Monitor menu 3-9**
 - 3.5.1 CPU Temperature / MB Temperature [xxx°C/xxx°F]..... 3-9
 - 3.5.2 Chassis Fan Speed [xxxx RPM] or [N/A] 3-9
 - 3.5.3 Chassis Q-Fan Control [Enabled] 3-10
 - 3.5.4 CPU Voltage, 3.3V Voltage, 5V Voltage, 12V Voltage .. 3-10
- 3.6 Boot menu 3-10**
 - 3.6.1 Bootup NumLock State [On] 3-10
 - 3.6.2 Full Screen Logo [Disabled] 3-11
 - 3.6.3 Wait for 'F1' If Error [Enabled] 3-11
 - 3.6.4 Boot Option Priorities 3-11
 - 3.6.5 Boot Override 3-11
- 3.7 Tools menu 3-11**
- 3.8 Exit menu 3-12**

Appendix

- Notices A-1**

Chapter 1

Product overview

1.1 Package contents

Check your industrial motherboard package for the following items.

- 1 x Industrial Motherboard
- 1 x Cable Kit
- 1 x DVD-ROM for manual (in PDF format) and drivers



NOTE: If any of the above items are damaged or missing, contact your distributor or sales representative immediately.

1.2 Features

- Integrated Intel® Atom™ processor N2600 / N2800 (optional)
- One Single Channel DDR3 800 / 1066MHz SO-DIMM Up To 2GB
- Realtek® ALC887, Audio Amplifier EUA 2012A
- Multi Display: LVDS+HDMI, VGA+LVDS, VGA+HDMI
- Dual Ethernet LAN: Realtek® 8111F x 2
- SATA 3Gb/s x 2, USB2.0 x 6, COM x 4
- 2 x Mini Card slots with PCIe and USB interface (1 x Full Height with SIM card interface, 1 x Half Height)
- EuP/ErP Compliance
- AMD® HD7410M (optional)

1.3 Specifications

SYSTEM	
CPU	Integrated Intel® Atom™ processor N2600 / N2800 (optional)
Memory	1 x SO-DIMM, max. 2GB, DDR3 800 / 1066MHz, non-ECC, un-buffered memory Single channel memory architecture
Chipset	Intel® NM10
I/O Chipset	Fintek 81866D-I
LAN	2 x Realtek® 8111F PCIe Gigabit LAN controllers
Audio	1 x Realtek® ALC887 8-channel high definition audio CODEC 1 x Audio Amplifier EUA 2012A
Expansion slot	2 x Mini Card slots with PCIe and USB interface (1 x Full Height with SIM card interface, 1 x Half Height)
BIOS	64Mb Flash ROM, UEFI AMI BIOS, PnP, DMI 2.0, Wfm 2.0, SM BIOS, ACPI 3.06
H/W Status Monitor	Monitors CPU/system temperature Monitors Vcore, 3.3V/5V/12V voltages Monitors chassis fan speed
Watchdog Timer	1~255 steps by software program
Smart Fan Control	Yes
Wake On LAN / PXE	Yes (WOL, PXE)
Power States	S3, S4, S5
Graphics	
Graphics Chipset	AMD® HD7410M with 512M memory (optional)
Graphics Multi Display	LVDS+HDMI, VGA+LVDS, VGA+HDMI
Resolution	VGA: Up to 1920 x 1200 @60Hz (optional) HDMI: Up to 1920 x 1200 @60Hz LVDS: Up to 2048 x 1536 @60Hz, 24 bit dual channel
LVDS Inverter Control	Voltage / PWM, 1 x DC 5V/12V for LCD backlight inverter board
Environment, Power, and ME	
Battery	Lithium battery
Power requirement	1 x DC connector on rear I/O 1 x onboard 2-pin power connector
Power compliance	Compliant with Eup/ErP
Operating temperature	14°F~131°F (-10°C~55°C)
Operating humidity	0%~90% relative humidity, non-condensing
Form factor	EPIC form factor: 4.53 in. x 6.5 in. (11.5 cm x 16.5 cm)
EMI	CE, FCC

(continued on the next page)

I/O	
Storage	2 x SATA 3Gb/s ports
USB	6 x USB 2.0 ports (2 ports at mid-board, 4 ports on rear I/O)
Display I/O	1 x LVDS connector, 1 x VGA connector, 1 x HDMI port
Audio I/O	Mic-In, Line-Out, S/PDIF onboard headers Amplifier onboard header HDMI support audio
LAN I/O	2 x RJ-45 ports on rear I/O
Serial port	1 x 5V/12V RS232/RS485 port on rear I/O (COM1) 3 x RS232 onboard headers (COM2, COM3, COM4)
PS/2 port	1 x PS/2 keyboard / mouse connector
DIO	8-bit Digital I/O interface (4-in/4-out)
Fan	1 x Chassis fan connector (4-pin)
RTC	Internal RTC
I/O Placement	
Back panel I/O ports	1 x HDMI port 1 x COM port (RS232/485) 2 x LAN (RJ-45) port 4 x USB 2.0 ports 1 x Lockable DC power port (12V)
Internal I/O connectors	1 x VGA pin header 1 x 12V DC power connector (2-pin) 2 x SATA 3Gb/s connectors 1 x 4-pin SATA power connector 1 x PS/2 keyboard/mouse connector (6-pin) 1 x USB 2.0 header supports additional 2 USB 2.0 ports 3 x RS232 COM connectors 1 x LVDS connector 1 x 5-pin LCD power connector 1 x Full Height Mini Card slot 1 x Half Height Mini Card slot 1 x SIM card connector 1 x 4-pin audio amplifier connector 1 x Line-Out / Mic-In audio pin header (AAFP) 1 x S/PDIF output pin header 1 x DIO connector 1 x Chassis Fan connector

(continued on the next page)

Others	
Supported OS	Windows® XP 32-bit Windows® XP 64-bit (only with AMD graphics) Windows® 7 32-bit Windows® 7 64-bit (only with AMD graphics) Windows® 8 32-bit Windows® 8 64-bit (only with AMD graphics) Linux Fedora
Accessories	1 x SATA 3Gb/s cable 1 x SATA power cable 1 x Support DVD (Drivers, Manual)



NOTE: Specifications are subject to change without notice.

Chapter 2

Motherboard information

2.1 Before you proceed

Take note of the following precautions before you install motherboard components or change any motherboard settings.



CAUTION!

- Unplug the power cord from the wall socket before touching any component.
 - Before handling components, use a grounded wrist strap or touch a safely grounded object or a metal object, such as the power supply case, to avoid damaging them due to static electricity.
 - Hold components by the edges to avoid touching the ICs on them.
 - Whenever you uninstall any component, place it on a grounded antistatic pad or in the bag that came with the component.
 - Before you install or remove any component, ensure that the power supply is switched off or the power cord is detached from the power supply. Failure to do so may cause severe damage to the motherboard, peripherals, or components.
-

2.2 Motherboard layout



NOTE: Place five screws into the holes indicated by circles to secure the motherboard to the chassis.



CAUTION! Do not overtighten the screws! Doing so can damage the motherboard.

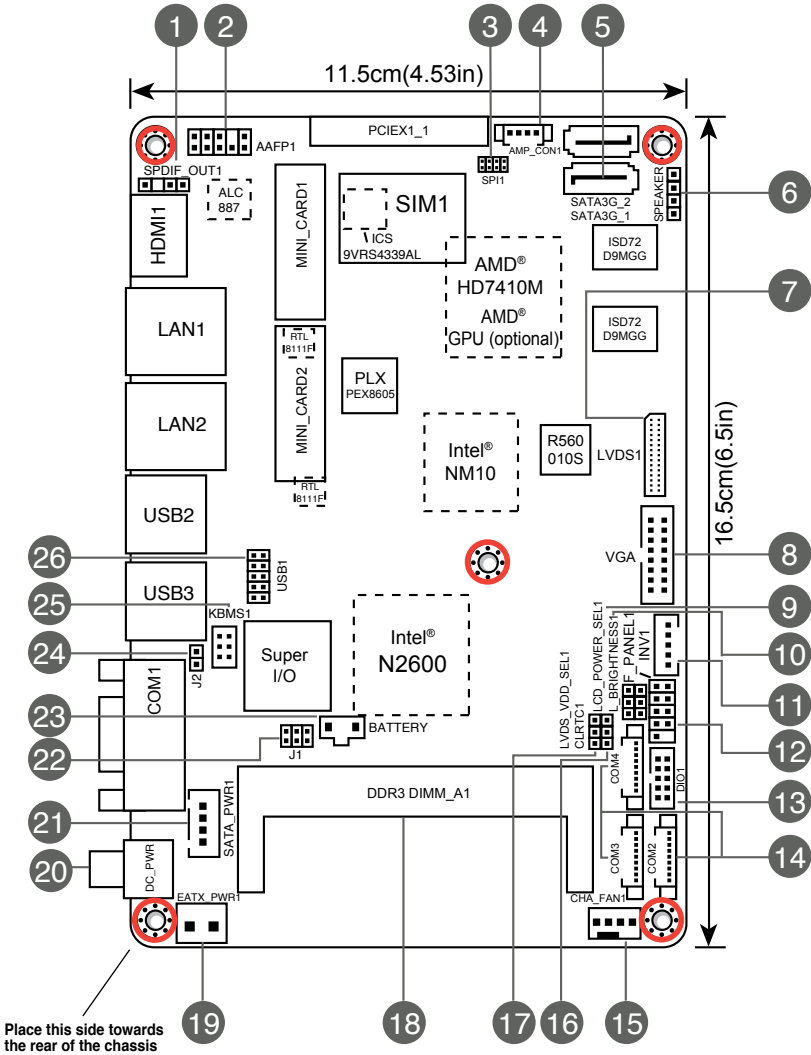

Connectors/Jumpers/Slots		Page
1.	Digital audio connector (4-1 pin SPDIF_OUT1)	2-13
2.	Line-Out / Mic-In audio connector (10-1 pin AAFP1)	2-13
3.	SPI programming connector (8-pin SPI1)	2-18
4.	Audio amplifier connector (4-pin AMP_CON1)	2-20
5.	Serial ATA 3Gb/s connectors (7-pin SATA3G_1/2)	2-17
6.	Internal speaker connector (4-pin SPEAKER)	2-15
7.	LVDS connector (30-pin LVDS1)	2-21
8.	VGA connector (16-pin VGA)	2-20
9.	LCD inverter power setting jumper (3-pin LCD_POWER_SEL1)	2-11
10.	LVDS backlight brightness control jumper (3-pin L_BRIGHTNESS1)	2-10
11.	Backlight inverter power connector (5-pin INV1)	2-19
12.	System panel connector (10-1 pin F_PANEL1)	2-16
13.	Digital I/O connector (10-pin DIO1)	2-22
14.	Serial port connectors (9-pin COM2/3/4)	2-14
15.	Chassis fan connector (4-pin CHA_FAN1)	2-15
16.	Clear RTC RAM (3-pin CLRRTC1)	2-8
17.	LVDS panel VDD setting jumper (3-pin LVDS_VDD_SEL1)	2-10
18.	DDR3 DIMM slot	2-6
19.	EATX power connector (2-pin EATX_PWR1)	2-14
20.	Lockable DC power port (DC_PWR)	2-12
21.	SATA power connector (4-pin SATA_PWR1)	2-17
22.	COM1 Ring and voltage selection (6-pin J1)	2-9
23.	Battery connector (2-pin BATTERY)	2-21
24.	AT Mode selection (2-pin J2)	2-9
25.	PS/2 keyboard/mouse connector (6-pin KBMS1)	2-19
26.	USB 2.0 connector (10-pin USB1)	2-18



NOTES:

- If your motherboard has an onboard AMD® GPU, you should install the display driver.
- If your motherboard does not have an onboard AMD® GPU, you should install the VGA driver.

2.3 Screw size

2.3.1 Component side

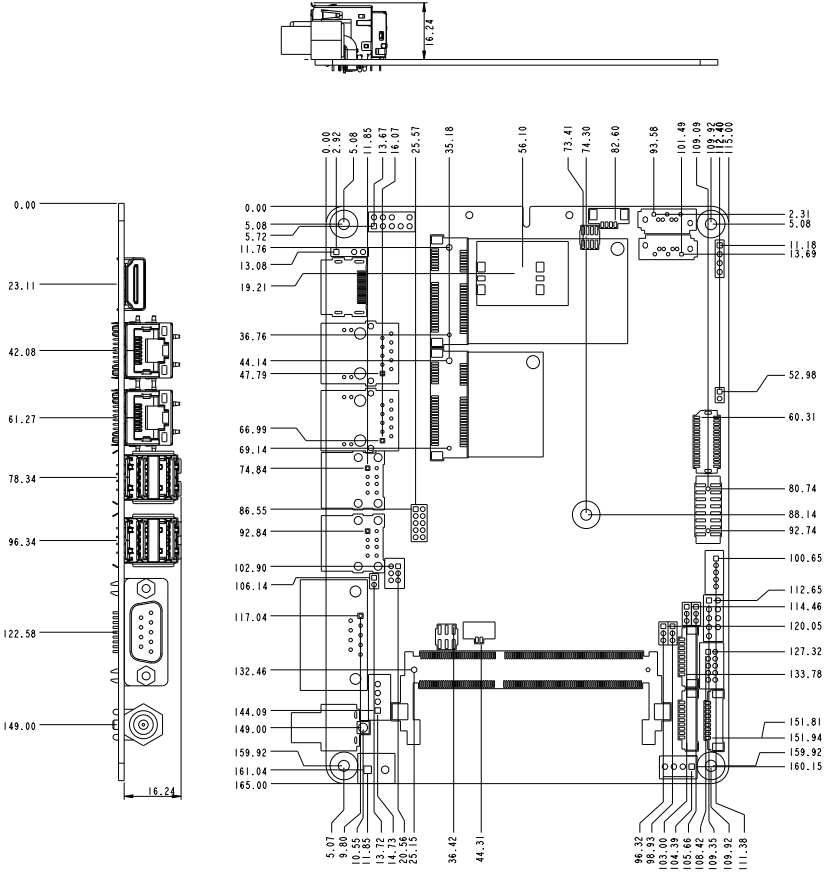

2.3.2 Solder side

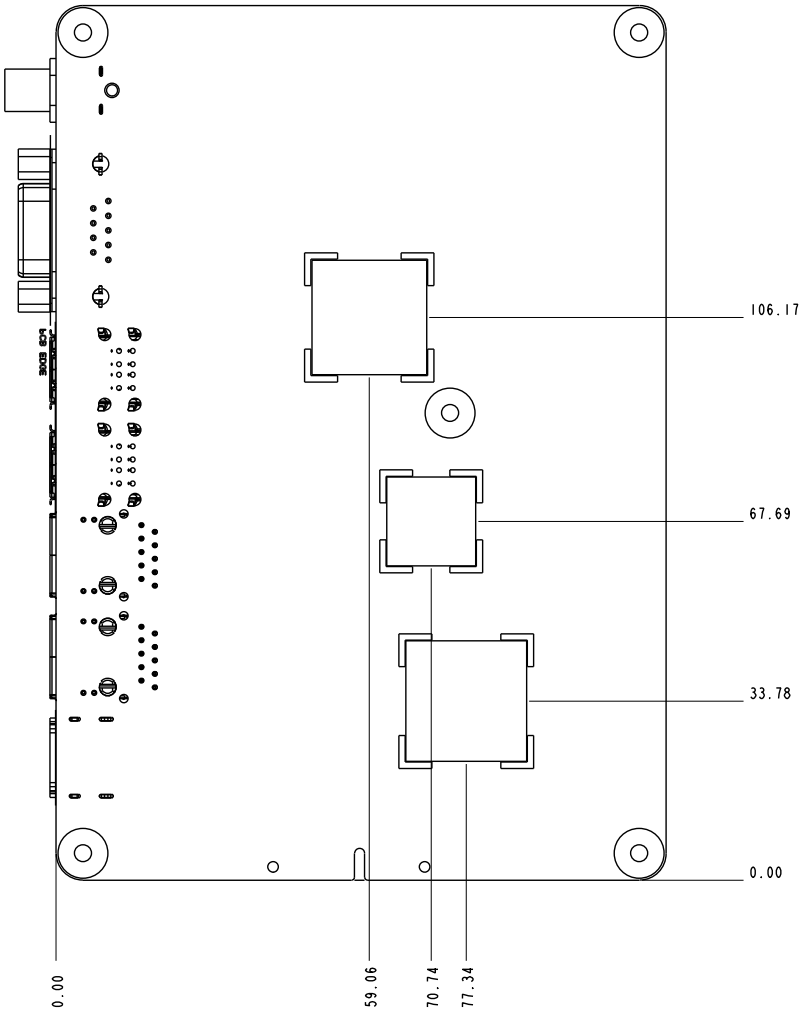

2.4 Central Processing Unit (CPU)

The motherboard comes with an integrated Intel® Atom™ processor N2600 / N2800 (optional).

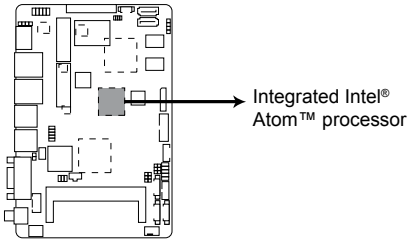

EPC-CV1 Series Integrated Intel® Atom™ processor

2.5 System memory

This motherboard comes with one Double Data Rate 3 (DDR3) Small Outline Dual Inline Memory Modules (SO-DIMM) socket. The figure illustrates the location of the DDR3 DIMM socket:

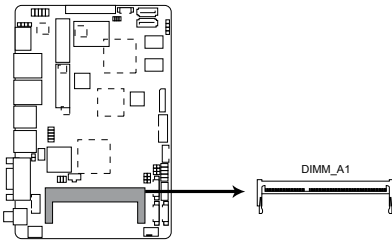

EPC-CV1 Series DDR3 DIMM socket

To install a DIMM

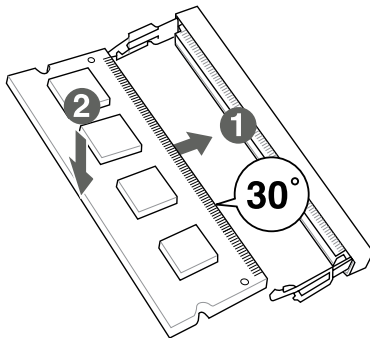

To remove a DIMM

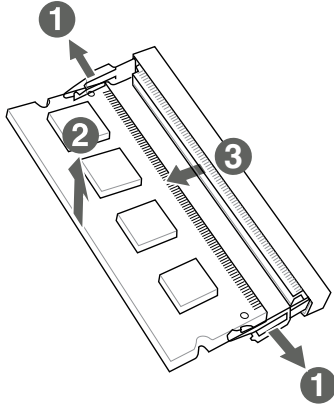

2.6 Jumpers

1. Clear RTC RAM (3-pin CLRTC1)

This jumper allows you to clear the Real Time Clock (RTC) RAM in CMOS. You can clear the CMOS memory of date, time, and system setup parameters by erasing the CMOS RTC RAM data. The onboard button cell battery powers the RAM data in CMOS, which include system setup information such as system passwords.

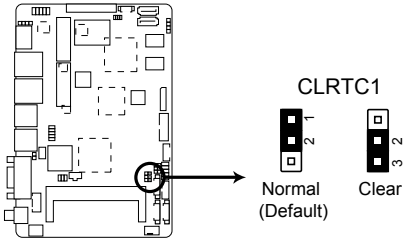

EPC-CV1 Series Clear CMOS RAM

To erase the RTC RAM:

1. Turn OFF the computer and unplug the power cord.
2. Move the jumper cap from pins 1-2 (default) to pins 2-3. Keep the cap on pins 2-3 for about 5~10 seconds, then move the cap back to pins 1-2.
3. Plug the power cord and turn ON the computer.
4. Hold down the **** key during the boot process and enter BIOS setup to reenter data.



CAUTION! Except when clearing the RTC RAM, never remove the cap on CLRTC1 jumper default position. Removing the cap will cause system boot failure!



NOTES:

- If the steps above do not help, remove the onboard battery and move the jumper again to clear the CMOS RTC RAM data. After clearing the CMOS, reinstall the battery.
 - You do not need to clear the RTC when the system hangs due to overclocking. For system failure due to overclocking, use the CPU Parameter Recall (C.P.R) feature. Shut down and reboot the system so the BIOS can automatically reset parameter settings to default values.
-

2. COM1 Ring and voltage selection (6-pin J1)

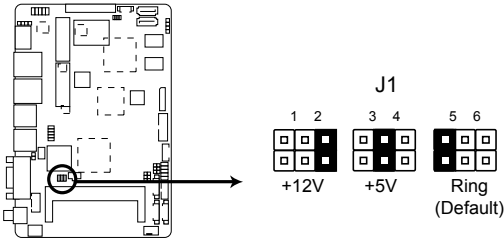

EPC-CV1 Series COM1 Ring and voltage selection

Pins	
1-2	+12V
3-4	+5V
5-6	Ring (Default)

3. AT Mode selection (2-pin J2)

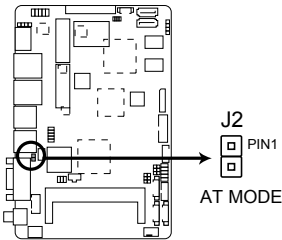

EPC-CV1 Series AT Mode selection

Pins	
1-2	AT Mode

4. LVDS backlight brightness control jumper (3-pin L_BRIGHTNESS1)

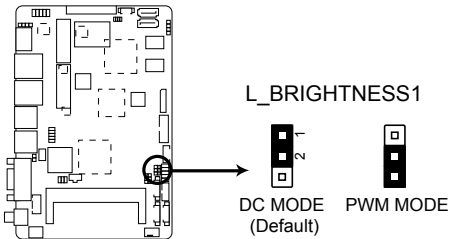

EPC-CV1 Series LVDS backlight brightness control jumper

Pins	
1-2	DC Mode (Default)
2-3	PWM Mode

5. LVDS panel VDD setting jumper (3-pin LVDS_VDD_SEL1)

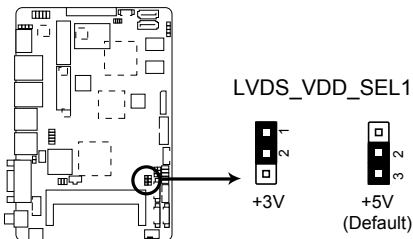

EPC-CV1 Series LVDS panel VDD setting jumper

Pins	
1-2	+3V
2-3	+5V (Default)

6. LCD inverter power setting jumper (3-pin LCD_POWER_SEL1)

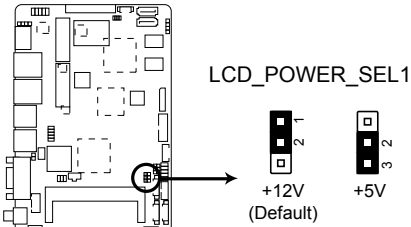

EPC-CV1 Series LCD inverter power setting jumper

Pins	
1-2	+12V (Default)
2-3	+5V

2.7 Connectors

2.7.1 Rear panel connectors

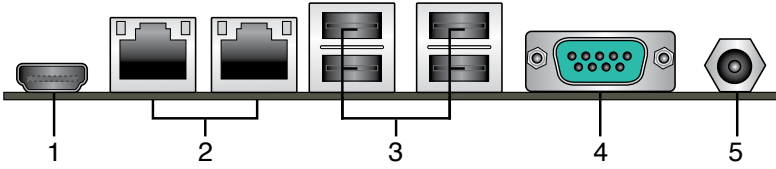

- HDMI port.** This port is for a High-Definition Multimedia Interface (HDMI) connector, and is HDCP compliant allowing playback of HD DVD, Blu-Ray, and other protected content.
- LAN (RJ-45) ports.** These ports allow Gigabit connection to a Local Area Network (LAN) through a network hub. Refer to the table below for the LAN port LED indications.

LAN port LED indications

ACT/LINK LED		SPEED LED	
Status	Description	Status	Description
OFF	No link	OFF	10 Mbps connection
ORANGE	Linked	ORANGE	100 Mbps connection
BLINKING	Data activity	GREEN	1 Gbps connection

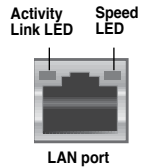

- USB 2.0 ports.** These two 12-pin Universal Serial Bus (USB) ports are available for connecting USB 2.0/1.1 devices.
- COM port.** This 9-pin COM1 port is for pointing devices or other serial devices.
- Lockable DC power port (+12V).** This port connects to a DC power adapter. To select the correct power adapter, refer to the inner and outer dimensions of this power port.

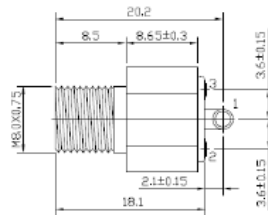
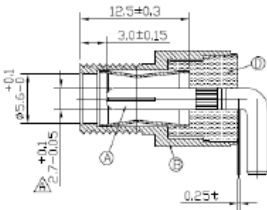

2.7.2 Internal connectors

1. Line-Out / Mic-In audio connector (10-1 pin AAFP1)

This connector is for Line-Out / Mic-In audio connection.

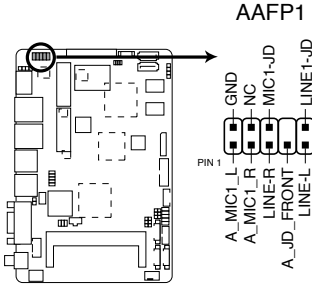

EPC-CV1 Series Line-Out / Mic-In audio connector

2. Digital audio connector (4-1 pin SPDIF_OUT1)

This connector is for an additional Sony/Philips Digital Interface (S/PDIF) port. Connect the S/PDIF Out module cable to this connector, then install the module to a slot opening at the back of the system chassis.

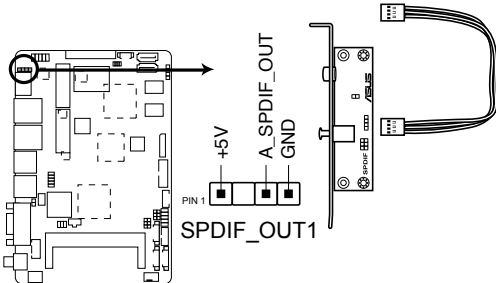

EPC-CV1 Series Digital audio connector



NOTE: The S/PDIF module is purchased separately.

3. EATX power connector (2-pin EATX_PWR1)

This connector is for EATX power supply plug. The power supply plug is designed to fit this connector in only one orientation. Find the proper orientation and push down firmly until the connector completely fits.

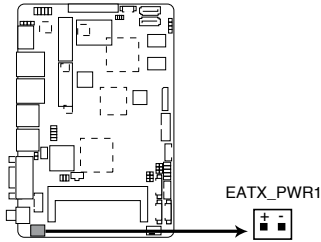

EPC-CV1 Series EATX power connector

4. Serial port connectors [WtoB CON 9P, 1.25mm, S/T, SMT / ACES / 50273-00971-001] (9-pin COM2/3/4)

These connectors are for serial (COM) ports. Connect the serial port module cable to this connector, then install the module to a slot opening at the back of the system chassis.

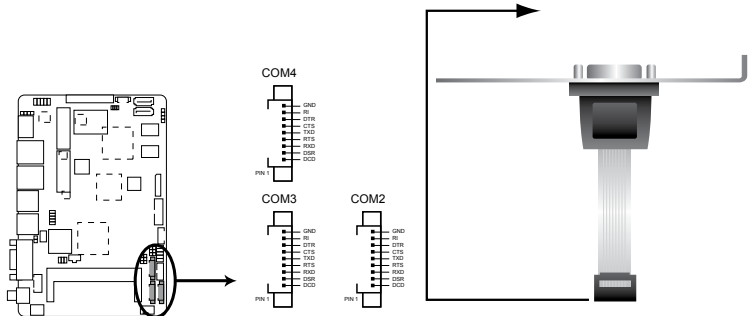

EPC-CV1 Series Serial port connectors



NOTE: The COM module is purchased separately.

5. Chassis fan connector (4-pin CHA_FAN1)

Connect the fan cable to the fan connector on the motherboard, ensuring that the black wire of the cable matches the ground pin of the connector.

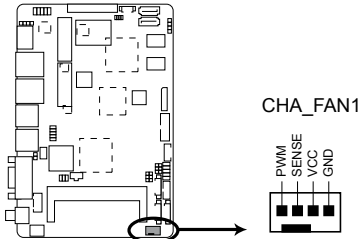

EPC-CV1 Series Chassis fan connector



CAUTION: Do not forget to connect the fan cable to the fan connector. Insufficient air flow inside the system may damage the motherboard components. This is not a jumper! Do not place jumper caps on the fan connector!

6. Internal speaker connector (4-pin SPEAKER)

The 4-pin connector is for the chassis-mounted system warning speaker. The speaker allows you to hear system beeps and warnings.

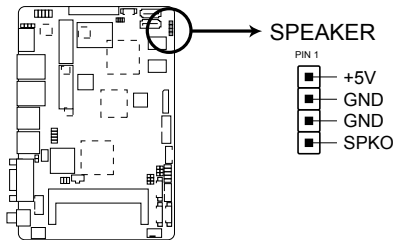

EPC-CV1 Series Internal speaker connector

7. System panel connector (10-1 pin F_PANEL1)

This connector supports several chassis-mounted functions.

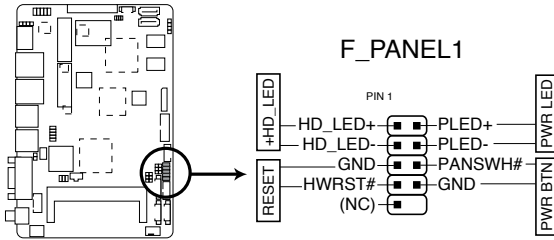

EPC-CV1 Series System panel connector

- **System power LED (2-pin PWR LED)**

This 2-pin connector is for the system power LED. Connect the chassis power LED cable to this connector. The system power LED lights up when you turn on the system power, and blinks when the system is in sleep mode.

- **Hard disk drive activity LED (2-pin +HD_LED)**

This 2-pin connector is for the HDD Activity LED. Connect the HDD Activity LED cable to this connector. The IDE LED lights up or flashes when data is read from or written to the HDD.

- **ATX power button/soft-off button (2-pin PWR BTN)**

This 2-pin connector is for the system power button.

- **Reset button (2-pin RESET)**

This 2-pin connector is for the chassis-mounted reset button for system reboot without turning off the system power.

8. Serial ATA 3Gb/s connectors (7-pin SATA3G_1/2])

These connectors connect to Serial ATA 3Gb/s hard disk drives and optical drives via Serial ATA 3Gb/s signal cables.

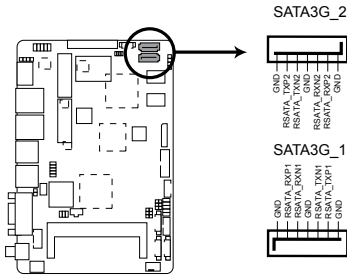

EPC-CV1 Series SATA 3.0Gb/s connectors



NOTES:

- These connectors are set to [IDE] by default. In IDE mode, you can connect Serial ATA boot/data hard disk drives to these connectors.
- You must install Windows® XP Service Pack 3 or later version before using Serial ATA hard disk drives.
- When using hot-plug and NCQ, set the **Configure SATA as** item in the BIOS to [AHCI]. See section 3.4.2 IDE Configuration for details.

9. SATA power connector (4-pin SATA_PWR1)

This connector is for the SATA power cable. The power cable plug is designed to fit this connector in only one orientation. Find the proper orientation and push down firmly until the connector completely fits.

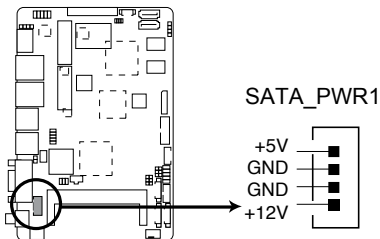

EPC-CV1 Series SATA power connector

10. USB 2.0 connector (10-pin USB1)

This connector is for USB 2.0 ports. Connect the USB module cable to this connector, then install the module to a slot opening at the back of the system chassis. This USB connector complies with USB 2.0 specification that supports up to 480 Mbps connection speed.

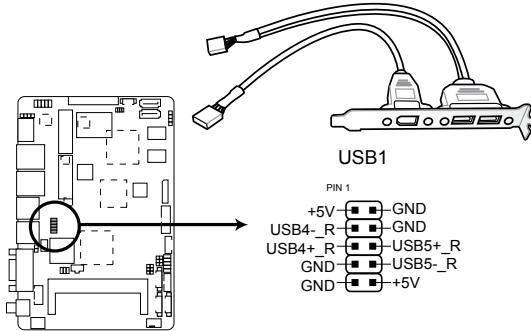

EPC-CV1 Series USB 2.0 connector



CAUTION! Never connect a 1394 cable to the USB connector. Doing so will damage the motherboard!



NOTE: The USB module cable is purchased separately.

11. SPI programming connector (8-pin SPI1)

Use this connector to flash BIOS SPI ROM.

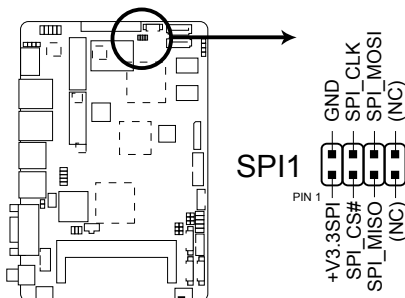

EPC-CV1 Series SPI programming connector

12. PS/2 keyboard/mouse connector (6-pin KBMS1)

This connector is for an IBM PS/2-compatible keyboard or mouse.

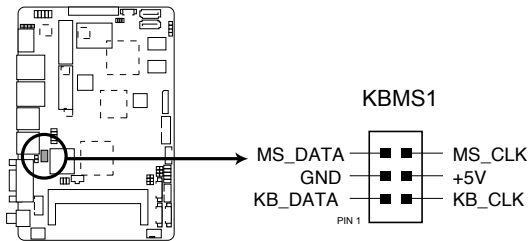

EPC-CV1 Series PS/2 keyboard/mouse connector

13. Backlight inverter power connector [WAFER HD 5P S/T 2.0mm WHITE / PINREX / 721-81-05TW00] (5-pin INV1)

Connect the backlight inverter power cable to this connector.

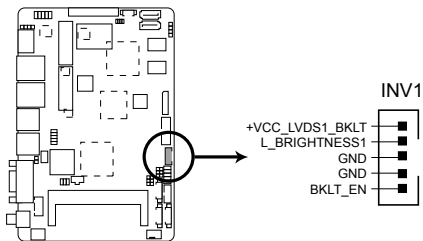

EPC-CV1 Series Backlight inverter power connector



NOTE: The backlight inverter power cable is purchased separately.

14. VGA connector [BOX HEADER 2X8P S/T 2.0mm SMT // PINREX / 52M-90-16GBE0] (16-pin VGA)

This 16-pin connector is for a VGA monitor or other VGA-compatible devices.

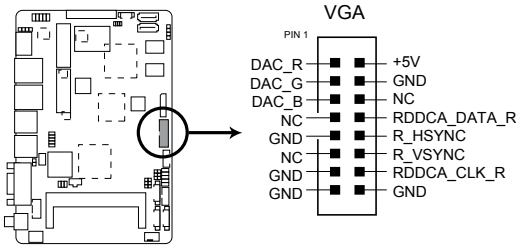

EPC-CV1 Series VGA connector

15. Audio amplifier connector [WtoB CON 4P, 1.25mm, S/T, SMT // ACES / 85025-04701] (4-pin AMP_CON1)

This connector is for an external audio amplifier.

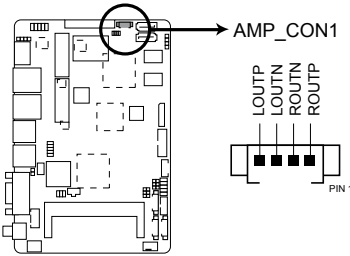

EPC-CV1 Series Speaker out connector

18. Digital I/O connector (10-pin DIO1)

This connector includes 8 I/O lines. All of the Digital I/O lines are programmable and each I/O pin can be individually programmed to support various devices.

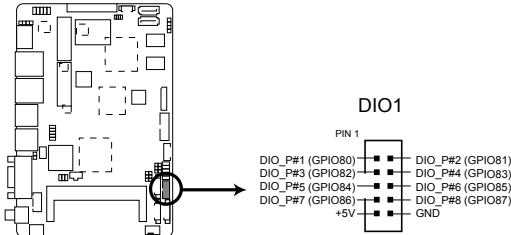

EPC-CV1 Series Digital I/O connector



NOTE: To configure the I/O pins in BIOS, go to the **Advanced** tab > **DIO Function** > **GPIO 1~8**. See section 3.4.6 **DIO Function** for details.

Chapter 3

BIOS setup

3.1 BIOS setup program

Use the BIOS Setup program to update the BIOS or configure its parameters. The BIOS screens include navigation keys and brief online help to guide you in using the BIOS Setup program.

Entering BIOS Setup at startup

To enter BIOS Setup at startup:

- Press <Delete> during the Power-On Self Test (POST). If you do not press <Delete>, POST continues with its routines.

Entering BIOS Setup after POST

To enter BIOS Setup after POST:

- Press <Ctrl>+<Alt>+ simultaneously.
- Press the reset button on the system chassis.
- Press the power button to turn the system off then back on. Do this option only if you failed to enter BIOS Setup using the first two options.



NOTE: Using the power button, reset button, or the <Ctrl>+<Alt>+ keys to force reset from a running operating system can cause damage to your data or system. We recommend to always shut down the system properly from the operating system.



IMPORTANT:

- The default BIOS settings for this motherboard apply for most conditions to ensure optimum performance. If the system becomes unstable after changing any BIOS settings, load the default settings to ensure system compatibility and stability. Select the **Load Optimized Defaults** item under the **Exit** menu. See section **3.8 Exit Menu** for details.
 - Ensure that a USB mouse is connected to your motherboard if you want to use the mouse to control the BIOS setup program.
 - The BIOS setup screens shown in this section are for reference purposes only, and may not exactly match what you see on your screen.
 - If the system fails to boot after changing any BIOS setting, try to clear the CMOS and reset the motherboard to the default value. See section **2.6 Jumpers** for information on how to erase the RTC RAM.
-

3.2 BIOS menu screen

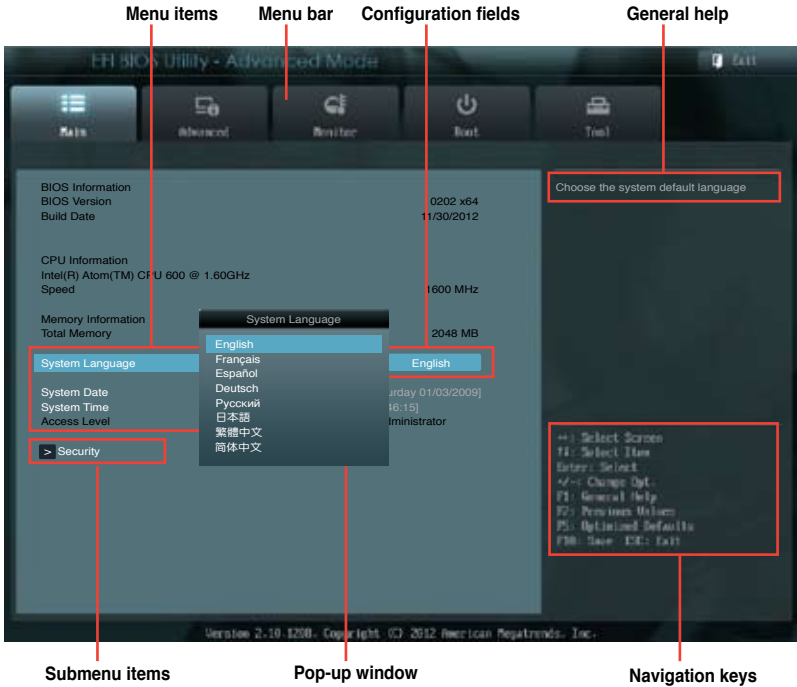

Menu bar

The menu bar on top of the screen has the following main items:

- Main** For changing the basic system configuration.
- Advanced** For changing the advanced system settings.
- Monitor** For displaying the system temperature, power status, and changing the fan settings
- Boot** For changing the system boot configuration.
- Tool** For configuring options for special functions.
- Exit** For selecting the exit options and loading default settings.

Menu items

The highlighted item on the menu bar displays the specific items for that menu. For example, selecting **Main** shows the Main menu items.

The other items (Ai Tweaker, Advanced, Monitor, Boot, Tool, and Exit) on the menu bar have their respective menu items.

Back button

This button appears when entering a submenu. Press <Esc> or use the USB mouse to click this button to return to the previous menu screen.

Submenu items

A greater than sign (>) before each item on any menu screen means that the item has a submenu. To display the submenu, select the item and press <Enter>.

Pop-up window

Select a menu item and press <Enter> to display a pop-up window with the configuration options for that item.

Navigation keys

At the bottom right corner of the menu screen are the navigation keys for the BIOS setup program. Use the navigation keys to select items in the menu and change the settings.

General help

At the top right corner of the menu screen is a brief description of the selected item.

Configuration fields

These fields show the values for the menu items. If an item is user-configurable, you can change the value of the field opposite the item. You cannot select an item that is not user-configurable.

A configurable field is highlighted when selected. To change the value of a field, select it and press <Enter> to display a list of options.

3.3 Main menu

The Main menu screen appears when you enter the Advanced Mode of the BIOS Setup program. The Main menu provides you an overview of the basic system information, and allows you to set the system date, time, language, and security settings.

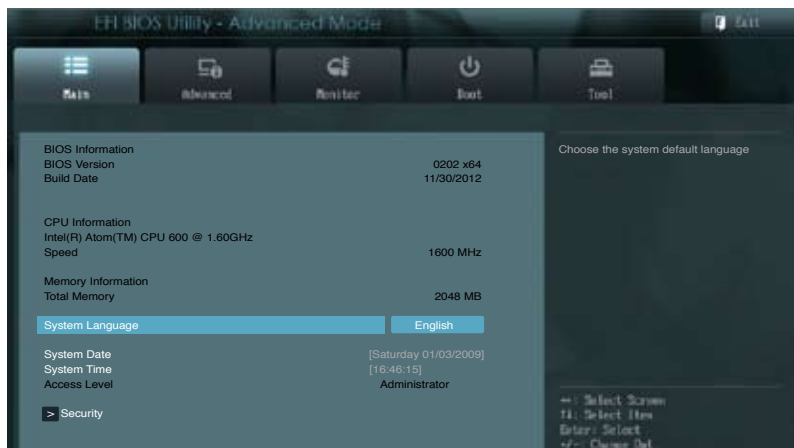

3.3.1 System Language [English]

Allows you to choose the BIOS language version from the options.

Configuration options: [English] [Français] [Español] [Deutsch] [Русский] [日本語] [繁體中文] [简体中文]

3.3.2 System Date [Day xx/xx/xxxx]

Allows you to set the system date.

3.3.3 System Time [xx:xx:xx]

Allows you to set the system time.

3.3.4 Security

The Security menu items allow you to change the system security settings.



NOTES:

- If you have forgotten your BIOS password, erase the CMOS Real Time Clock (RTC) RAM to clear the BIOS password. See section **2.6 Jumpers** for information on how to erase the RTC RAM.
- The **Administrator** or **User Password** items on top of the screen show the default **Not Installed**. After you set a password, these items show **Installed**.

Administrator Password

If you have set an administrator password, we recommend that you enter the administrator password for accessing the system. Otherwise, you might be able to see or change only selected fields in the BIOS setup program.

To set an administrator password:

1. Select the **Administrator Password** item and press <Enter>.
2. From the **Create New Password** box, key in a password, then press <Enter>.
3. Confirm the password when prompted.

To change an administrator password:

1. Select the **Administrator Password** item and press <Enter>.
2. From the **Enter Current Password** box, key in the current password, then press <Enter>.
3. From the **Create New Password** box, key in a new password, then press <Enter>.
4. Confirm the password when prompted.

To clear the administrator password, follow the same steps as in changing an administrator password, but press <Enter> when prompted to create/confirm the password. After you clear the password, the **Administrator Password** item on top of the screen shows **Not Installed**.

User Password

If you have set a user password, you must enter the user password for accessing the system. The **User Password** item on top of the screen shows the default **Not Installed**. After you set a password, this item shows **Installed**.

To set a user password:

1. Select the **User Password** item and press <Enter>.
2. From the **Create New Password** box, key in a password, then press <Enter>.
3. Confirm the password when prompted.

To change a user password:

1. Select the **User Password** item and press <Enter>.
2. From the **Enter Current Password** box, key in the current password, then press <Enter>.
3. From the **Create New Password** box, key in a new password, then press <Enter>.
4. Confirm the password when prompted.

To clear the user password, follow the same steps as in changing a user password, but press <Enter> when prompted to create/confirm the password. After you clear the password, the **User Password** item on top of the screen shows **Not Installed**.

3.4 Advanced menu

The Advanced menu items allow you to change the settings for the CPU and other system devices.



CAUTION: Be cautious when changing the settings of the Advanced menu items. Incorrect field values can cause the system to malfunction.

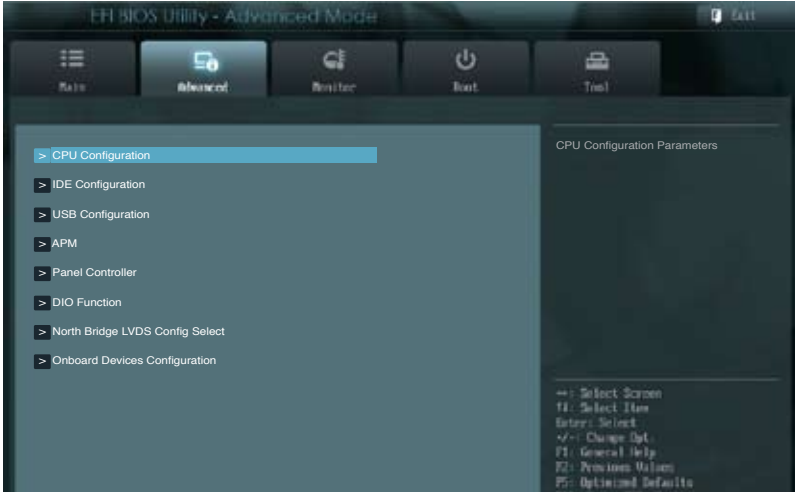

3.4.1 CPU Configuration

The items in this menu show the CPU-related information that the BIOS automatically detects.

Hyper-threading [Enabled]

The Intel Hyper-Threading Technology allows a hyper-threading processor to appear as two logical processors to the operating system, allowing the operating system to schedule two threads or processes simultaneously.

[Enabled] Two threads per activated core are enabled.

[Disabled] Only one thread per activated core is enabled.

Limit CPUID Maximum [Disabled]

[Enabled] Allows legacy operating systems to boot even without support for CPUs with extended CPUID functions.

[Disabled] Disables this function.

3.4.2 IDE Configuration

While entering Setup, the BIOS automatically detects the presence of SATA devices. The SATA Port items show **Not Present** if no SATA device is installed to the corresponding SATA port.

SATA Controller(s) [Enabled]

[Disabled] Disables the onboard SATA controllers.

[Enabled] Enables the onboard SATA controllers.

Configure SATA as [IDE]

Allows you to set the SATA configuration.

[IDE] Set to [IDE] when you want to use the Serial ATA hard disk drives as Parallel ATA physical storage devices.

[AHCI] Set to [AHCI] when you want the SATA hard disk drives to use the AHCI (Advanced Host Controller Interface). The AHCI allows the onboard storage driver to enable advanced Serial ATA features that increases storage performance on random workloads by allowing the drive to internally optimize the order of commands.

3.4.3 USB Configuration

The items in this menu allow you to change the USB-related features.



NOTE: The **USB Devices** item shows the auto-detected values. If no USB device is detected, the item shows **None**.

EHCI Hand-off [Disabled]

[Enabled] Enables the support for operating systems without an EHCI hand-off feature.

[Disabled] Disables the function.

3.4.4 APM

Restore AC Power Loss [Power Off]

[Power On] The system goes into on state after an AC power loss.

[Power Off] The system goes into off state after an AC power loss.

[Last State] The system goes into either off or on state, whatever the system state was before the AC power loss.

Power On By PCIE [Disabled]

[Disabled] Disables the PCIE devices to generate a wake event.

[Enabled] Enables the PCIE devices to generate a wake event.

Power On By Ring [Disabled]

[Disabled] Disables Ring to generate a wake event.

[Enabled] Enables Ring to generate a wake event.

3.4.5 Panel Controller (AMD® GPU only)

Backlight Brightness Setting [75]

Allows you to set the backlight brightness. Select a larger number for a brighter backlight. Configuration options: [0] [25] [50] [75] [100]

3.4.6 DIO Function

GPIO 1~8 [Input]

Allows you to configure the digital signal of the GPIO (General Purpose Input/Output) pins 1~8. Configuration options: [Input] [Output High] [Output Low]

3.4.7 North Bridge LVDS Config Select (AMD® GPU only)

LVDS Panel Config Select [1024x768]

Allows you to configure the resolution for the LVDS panel. Configuration options: [800x600 18bit] [800x480 18bit] [1024x768 24bit] [1280x800 18bit] [1280x1024 48bit] [1440x900 48bit] [1680x1050 48bit] [1920x1080 48bit]

EDID Panel Option [Enabled]

Enables or disables the EDID panel. Configuration options: [Enabled] [Disabled]

3.4.8 Onboard Devices Configuration

Onboard WLAN [Enabled]

[Enabled] Enables the onboard wireless LAN / WiMAX.

[Disabled] Disables the onboard wireless LAN / WiMAX.

Onboard Audio [Enabled]

[Enabled] Enables the onboard audio controller.

[Disabled] Disables the controller.

RS Mode [RS232]

Allows you to configure the serial communications standard of serial port (COM) 1. Configuration options: [RS232] [RS422] [RS485]

Onboard LAN [Enabled]

[Enabled] Enables the Realtek LAN controller.

[Disabled] Disables the controller.

Onboard LAN Boot ROM [Disabled]

This item appears only when you set the **Onboard LAN** item to [Enabled] and allows you to enable or disable the Boot ROM of the onboard LAN controller. Configuration options: [Enabled] [Disabled]

3.5 Monitor menu

The Monitor menu displays the system temperature/power status, and allows you to change the fan settings.



3.5.1 CPU Temperature / MB Temperature [xxx°C/xxx°F]

The onboard hardware monitor automatically detects and displays the CPU and motherboard temperatures. Select **Ignore** if you do not wish to display the detected temperatures.

3.5.2 Chassis Fan Speed [xxxx RPM] or [N/A]

The onboard hardware monitor automatically detects and displays the chassis fan speed in rotations per minute (RPM). If the fan is not connected to the motherboard, the field shows **N/A**.

3.5.3 Chassis Q-Fan Control [Enabled]

[Disabled] Disables the Chassis Q-Fan control feature.

[Enabled] Enables the Chassis Q-Fan control feature.

Chassis Fan Profile [Standard]

This item appears only when you enable the **Chassis Q-Fan Control** feature and allows you to set the appropriate performance level of the chassis fan.

[Standard] Sets to [Standard] to make the chassis fan automatically adjust depending on the chassis temperature.

[Silent] Sets to [Silent] to minimize the fan speed for quiet chassis fan operation.

[Turbo] Sets to [Turbo] to achieve maximum chassis fan speed.

3.5.4 CPU Voltage, 3.3V Voltage, 5V Voltage, 12V Voltage

The onboard hardware monitor automatically detects the voltage output through the onboard voltage regulators. Select **Ignore** if you do not want to detect this item.

3.6 Boot menu

The Boot menu items allow you to change the system boot options.



3.6.1 Bootup NumLock State [On]

[On] Sets the power-on state of the NumLock to [On].

[Off] Sets the power-on state of the NumLock to [Off].

3.6.2 Full Screen Logo [Disabled]

[Enabled] Enables the full screen logo display feature.

[Disabled] Disables the full screen logo display feature.

3.6.3 Wait for 'F1' If Error [Enabled]

When this item is set to [Enabled], the system waits for the F1 key to be pressed when error occurs. Configuration options: [Disabled] [Enabled]

3.6.4 Boot Option Priorities

These items specify the boot device priority sequence from the available devices. The number of device items that appears on the screen depends on the number of devices installed in the system.



NOTES:

- To select the boot device during system startup, press <F8> after the first screen appears.
 - To access Windows OS in Safe Mode, press <F8> after POST.
-

3.6.5 Boot Override

These items displays the available devices. The number of device items that appears on the screen depends on the number of devices installed in the system. Click an item to start booting from the selected device.

3.7 Tools menu

The Tools menu items allow you to configure options for special functions. Select an item then press <Enter> to display the submenu.

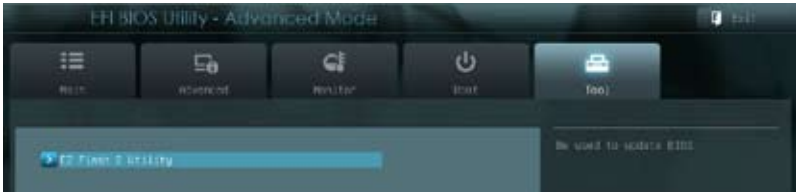

EZ Flash 2 Utility

Allows you to run EZ Flash 2. Press [Enter] to launch the EZ Flash 2 screen.

3.8 Exit menu

The Exit menu items allow you to load the optimal default values for the BIOS items, and save or discard your changes to the BIOS items. You can access the EZ Mode from the Exit menu.



Load Optimized Defaults

This option allows you to load the default values for each of the parameters on the Setup menus. When you select this option or if you press <F5>, a confirmation window appears. Select Yes to load the default values.

Save Changes & Reset

Once you are finished making your selections, choose this option from the Exit menu to ensure the values you selected are saved. When you select this option or if you press <F10>, a confirmation window appears. Select Yes to save changes and exit.

Discard Changes & Exit

This option allows you to exit the Setup program without saving your changes. When you select this option or if you press <Esc>, a confirmation window appears. Select Yes to discard changes and exit.

Appendix

Notices

Federal Communications Commission Statement

This device complies with Part 15 of the FCC Rules. Operation is subject to the following two conditions:

- This device may not cause harmful interference.
- This device must accept any interference received including interference that may cause undesired operation.

This equipment has been tested and found to comply with the limits for a Class A digital device, pursuant to Part 15 of the FCC Rules. These limits are designed to provide reasonable protection against harmful interference in a residential installation. This equipment generates, uses and can radiate radio frequency energy and, if not installed and used in accordance with manufacturer's instructions, may cause harmful interference to radio communications. However, there is no guarantee that interference will not occur in a particular installation. If this equipment does cause harmful interference to radio or television reception, which can be determined by turning the equipment off and on, the user is encouraged to try to correct the interference by one or more of the following measures:

- Reorient or relocate the receiving antenna.
- Increase the separation between the equipment and receiver.
- Connect the equipment to an outlet on a circuit different from that to which the receiver is connected.
- Consult the dealer or an experienced radio/TV technician for help.



WARNING! The use of shielded cables for connection of the monitor to the graphics card is required to assure compliance with FCC regulations. Changes or modifications to this unit not expressly approved by the party responsible for compliance could void the user's authority to operate this equipment.



DO NOT throw the motherboard in municipal waste. This product has been designed to enable proper reuse of parts and recycling. This symbol of the crossed out wheeled bin indicates that the product (electrical and electronic equipment) should not be placed in municipal waste. Check local regulations for disposal of electronic products.



DO NOT throw the mercury-containing button cell battery in municipal waste. This symbol of the crossed out wheeled bin indicates that the battery should not be placed in municipal waste.



電子信息產品污染控制標示：圖中之數字為產品之環保使用期限。僅指電子信息產品中含有的有毒有害物質或元素不致發生外洩或突變從而對環境造成污染或對人身、財產造成嚴重損害的期限。

有毒有害物質或元素的名稱及含量說明標示：

部件名稱	有害物質或元素					
	鉛 (Pb)	汞 (Hg)	鎘 (Cd)	六價鉻 (Cr(VI))	多溴聯苯 (PBB)	多溴二苯醚 (PBDE)
印刷電路板及其電子組件	×	○	○	○	○	○
外部信號連接頭及線材	×	○	○	○	○	○

○：表示該有毒有害物質在該部件所有均質材料中的含量均在 SJ/T 11363-2006 標準規定的限量要求以下。

×：表示該有毒有害物質至少在該部件的某一均質材料中的含量超出 SJ/T 11363-2006 標準規定的限量要求，然該部件仍符合歐盟指令 2002/95/EC 的規範。

備註：此產品所標示之環保使用期限，係指在一般正常使用狀況下。