

## ARM-LA0115

- LCD Flat Panel Monitor Arm (VESA 75/100)

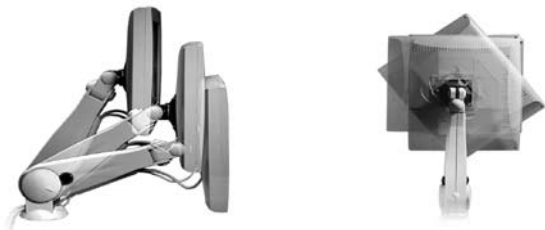

### Features

- SUSPA Series System Ensures The Stability Of Product And Strength Of Quality
- Supports Monitors From 8 Kg To 15 Kg Depending On Users' Demands
- Y-Y Connection Adjusts In Different Positions For Comfortable Viewing
- Cable Location Helps To Organize The Cables In Order
- Adjusting Knob Adapts To Different Monitor Weights
- Screen Pivots 180° Front or Back
- Screen Pivots 180° Up or Down
- Screen Pivots 270° Left Or Right

- Gross Weight: 11 lb (5 Kg)
- Supports AOP-9150, AOP-9120, AOP-8120, AOP-8150, APC-9172, APC-8172, APC-8152, APC-8122, OPD-212A, OPD-215A, OPD-217A, AMB-232, OPD-215E

### Ordering Information

- ARM-LA0115  
LCD Flat Panel Monitor Arm

### Dimension

Unit: mm

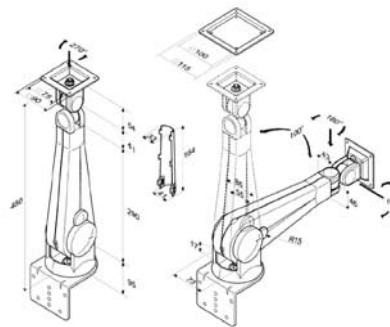

## ARM-WK075-0

- LCD Flat Panel Monitor Wallmount Kit (VESA 75/100)



### Ordering Information

- ARM-WK075-0  
LCD Flat Panel Monitor Wallmount Kit with VESA 75/100mm Standards

### Dimension

Unit: mm

