

Wireless LAN Kit

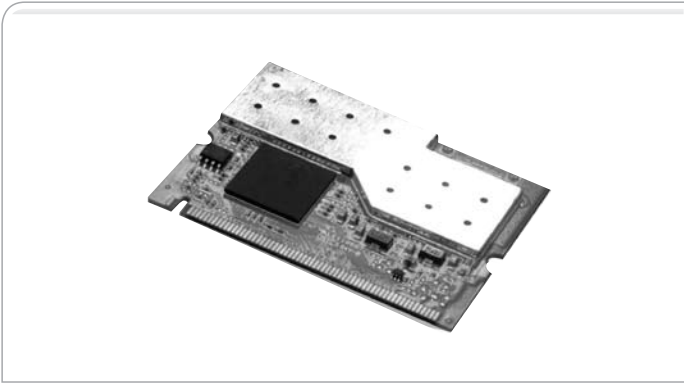

Specifications

Main Specifications	
IEEE Standard	802.11b/g
Data Rate	Up to 108 Mbps
OS Support	Windows® 98 SE/ME/2000/XP, Linux
Operating Temperature	32°F ~131°F (0°C ~55°C)

Ordering Information

- **9741666646**
Wireless LAN Kit. IEEE 802.11b/g. With Internal Cable and Antenna

ARM-LA0115

LCD Flat Panel Monitor Arm (VESA 75/100)

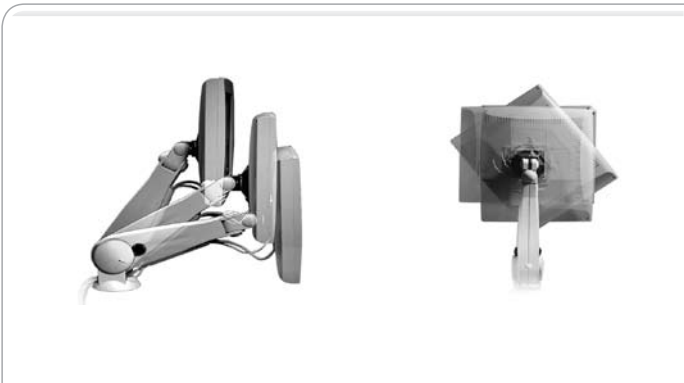

Features

- SUSPA Series System Ensures The Stability Of Product And Strength Of Quality
- Supports Monitors from 8 Kg To 15 Kg Depending On Users' Demands
- Y-Y Connection Adjusts In Different Positions For Comfortable Viewing
- Cable Location Helps To Organize The Cables In Order
- Adjusting Knob Adapts To Different Monitor Weights

- Screen Pivots 180° Front Or Back
- Screen Pivots 180° Up Or Down
- Screen Pivots 270° Left Or Right
- Gross Weight: 11 lb (5 Kg)
- Supports AOP-9150, AOP-9120, AOP-8120, AOP-8150, APC-9172, APC-8172, APC-8152, APC-8122, OPD-212A, OPD-215A, OPD-217A, OPD-215E, AMB-232

Ordering Information

- **ARM-LA0115**
LCD Flat Panel Monitor Arm

Dimension Unit: mm

