

ECB-970

Qseven Rev. 2.0 Carrier Board for ARM/x86 Solutions

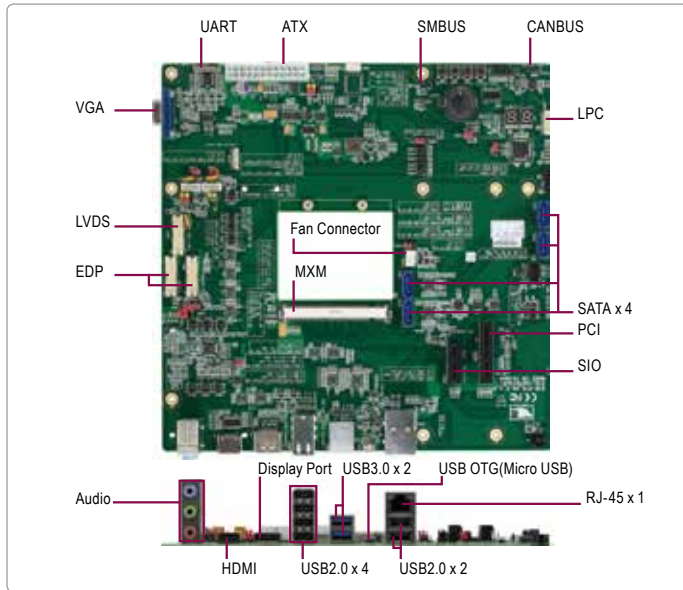

Features

- Supports Qseven Module
- Support ARM/x86 Based
- Supports Gigabit Ethernet, RJ-45
- Up to 24-bit Dual-Channel LVDS Connector or EDP, DP or HDMI
- High Definition Audio or I2S Audio Interface
- SATA Port x 2, SDIO x 1
- USB 2.0 x 8, USB 3.0 x 2, USB OTG
- LPC Connector x 1
- Qseven 2.0
- Micro ATX Form Factor



Specifications

System	
Form Factor	Micro ATX
I/O Chipset	Winbond W83627DHG-P or Fintek F81866 (optional)
Ethernet	10/1000/1000Base-TX, RJ-45 x 1 (From CPU module)
Expansion Interface	PCI Express [x4] x 1, LPC Connector x 1 (For Super I/O Card only)
Power Requirement	+5V DC
Power Consumption (Typical)	—
Board Size	9.65" x 9.65" (243.84mm x 243.84mm)
Gross Weight	1.32 lb (0.6 Kg)
Operation Temperature	32°F ~ 140°F (0°C ~ 60°C)
Storage Temperature	-40°F ~ 185°F (-40°C ~ 85°C)
Operation Humidity	0% ~ 90% relative humidity, non-condensing
MTBF (Hours)	—
Display	LVDS or EDP, DP or HDMI
LCD Interface	Up to 24-bit Dual-Channel LVDS
I/O	—
Storage	SATA x 2, SDIO x 1
Serial Port	RS-232 x 1, RS-232/422/485 x 1
Parallel Port	—
USB	USB 2.0 x 8, USB3.0 x 2, USB OTG
PS/2 Port	—
I2C	1
Audio	Audio Jack, supports Line-in, Line-out, Microphone, Headphone (ARM base only)
Debug LED	—

Packing List

- Product CD
- ECB-970

ECB-970

Dimension

Unit: mm

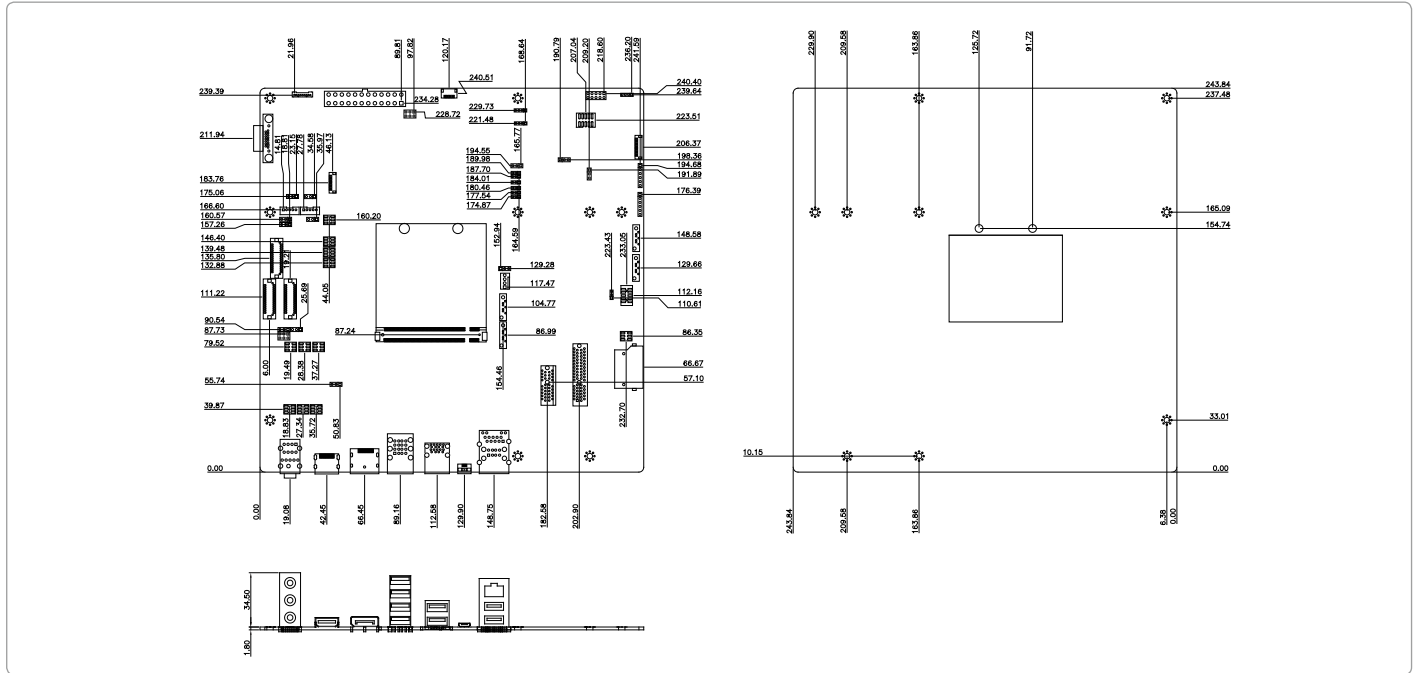

Ordering Information

- **ECB-970-A10-00**
Qseven Carrier Board, GbE, LVDS, Audio, COM, USB2.0, USB3.0, DC, Rev. A1.0 for A07-LN
- **ECB-970-A10-01**
Qseven Carrier Board, GbE, LVDS, Audio, COM, USB2.0, USB3.0, USB OTG, DC, Rev. A1.0 for A07-IMX6